



SFC1450A/SFC6400A

Synthesized Frequency Upconverter Installation and Operation Manual

Part Number MN-SFC1450-6400

Revision 5

April 6, 2011

IMPORTANT NOTE: The information contained in this document supersedes all previously published information regarding this product. This manual is subject to change without prior notice.

Table of Contents

TABLE OF CONTENTS	III
CHAPTER 1. INTRODUCTION.....	1-1
1.1 Description.....	1-1
1.2 Protection Switch Versatility	1-3
1.3 Chain Switching (Optional).....	1-3
CHAPTER 2. INSTALLATION	2-1
2.1 Installation Requirements	2-1
2.2 Unpacking.....	2-2
2.3 Removal and Assembly.....	2-2
2.4 Mounting Considerations.....	2-2
2.5 Initial Power-Up.....	2-2
CHAPTER 3. THEORY OF OPERATION	3-1
3.1 Theory of Operation	3-1
3.2 Converter Configuration.....	3-3
3.2.1 Stand-Alone Operation	3-3
3.2.2 1:1 Switch	3-3
3.2.3 1:8 Switch	3-3
3.3 Optional Chain Switching Operation.....	3-3
CHAPTER 4. FRONT PANEL INTERFACE.....	4-1
4.1 User Interfaces	4-1
4.2 Front Panel User Interface.....	4-1
4.2.1 Monitoring Ports	4-2
4.2.2 LCD Display	4-2
4.2.3 Cursor Control Arrows.....	4-2
4.2.4 Front Panel Keypad.....	4-3
4.2.5 LED Indicators.....	4-3

4.3	Front Panel Control Screen Menus	4-4
4.3.1	Main Menu	4-4
4.3.2	Converter Menu Options and Parameters	4-4
4.3.3	Switch Menu Options and Parameters	4-5
4.3.4	Monitor Menu Options and Parameters	4-7
4.3.5	Alarms Menu Options and Parameters	4-8
4.3.6	System Menu Options and Parameters	4-10
4.3.7	Test Menu Options and Parameters	4-13
4.4	Examples: Changing Parameters from the Front Panel	4-16
4.4.1	Changing Frequency: Numeric Keypad	4-16
4.4.2	Changing Frequency: Up/Down Arrow Keys	4-17
4.4.3	Changing Control Mode to 'TERMINAL'	4-17
4.4.4	Changing Control Mode Back to 'FT PANEL'	4-18
4.5	Remote Port User Interfaces	4-18
4.5.1	ASCII Serial Protocol	4-19
4.5.1.1	ASCII Command Structure	4-19
4.5.2	RLLP Serial Protocol	4-19
4.5.2.1	RLLP Protocol Structure	4-20
4.5.2.2	RLLP Protocol Wrapper	4-20
4.5.2.3	Frame Description and Bus Handshaking	4-22
4.5.2.4	Global Response Operational Codes	4-23
4.5.2.5	Collision Avoidance	4-25
4.5.2.6	Software Compatibility	4-26
4.5.2.7	RLLP Summary	4-27
4.6	Terminal Port User Interface	4-28
4.6.1	Terminal Main Menu	4-28
4.6.2	Terminal Converter Controls Menu	4-29
4.6.3	Terminal Switch Controls Menu	4-29
4.6.4	Terminal Alarm Status & Masks Menu	4-30
4.6.5	Terminal Monitor Status Menu	4-30
4.6.6	Terminal Test Controls Menu	4-31
4.6.7	SNMP Controls Menu	4-31
4.6.8	Terminal Event Buffer Menu	4-32
4.7	Ethernet Port User Interface	4-32
4.7.1	Ethernet Port Configuration	4-32
4.7.1.1	Connecting the Terminal	4-32
4.7.1.2	SNMP Option	4-33
4.7.2	Network Configuration	4-33
4.7.2.1	Terminal Screens	4-33
4.7.2.2	Logging on and Passwords	4-33
4.7.2.3	Exiting SNMP Configuration	4-34
4.7.2.4	Logging On	4-34
4.7.2.5	Changing the Logon Password	4-34
4.7.2.6	Logging Off	4-34
4.7.2.7	Changing Your Authentication Password	4-35
4.7.2.8	Changing Your Privacy Password	4-35
4.7.2.9	Converter Ethernet Address	4-35

4.7.2.10	Converter IP Address	4-36
4.7.2.11	Server Ethernet Address.....	4-36
4.7.2.12	Server IP Address.....	4-36
4.7.2.13	Router IP Address	4-36
4.7.2.14	IP Address Mask	4-36
4.7.2.15	Boot Mode (Optional).....	4-37
4.7.2.16	Community	4-37
4.7.2.17	Trap Type and Trap Hosts	4-37
4.7.2.18	Trace Mode	4-37
4.7.2.19	SNMP V1 & 2 Access View.....	4-37
4.7.2.20	Key Generation Mode.....	4-37
4.7.2.21	Context Engine ID	4-38
4.7.3	4.6.3 Connecting the Ethernet Cable and Testing the Link	4-39
4.7.3.1	Ping Program	4-39
4.7.3.2	SNMP Test.....	4-40
4.7.4	Management Information Base Structure	4-40
4.7.4.1	Simple Network Management Protocol (SNMP)	4-40
4.7.4.2	The Management Information Base (MIB).....	4-40
CHAPTER 5. REAR PANEL INTERFACES		5-1
5.1	SFC Upconverter Connections	5-1
5.2	Power.....	5-1
5.3	10 MHz Ref In (J4)	5-2
5.4	10 MHz Ref Out (J3).....	5-2
5.5	Test/Fault (J7)	5-2
5.6	Operator Serial I/O (J8)	5-2
5.7	IF In (J2).....	5-3
5.8	Terminal (J6).....	5-3
5.9	Ethernet (J9).....	5-4
5.10	Equipment RS-485 (J10), Standard Backward Compatible Interface.....	5-4
5.11	B/U Switch Interface (J5), Standard Backward Compatible Interface	5-5
5.12	RF Out (J1).....	5-6
5.13	Monitor Ports	5-6
5.13.1	IF Monitor Port	5-7
5.13.2	RF Monitor Port.....	5-7
5.14	Optional Chain Switching Module	5-7
5.14.1	(J10)	5-7

5.14.2	(J11)	5-7
5.14.3	(J12 and J13)	5-7
5.14.4	(J14)	5-7
5.14.5	(J15)	5-7
5.14.6	(J16 and J17)	5-7
5.14.7	(J18), Chain Switch Module	5-8
5.14.8	(J19), Chain Switch Module, Primary Only.....	5-9
CHAPTER 6.	MAINTENANCE AND TROUBLESHOOTING	6-1
6.1	Periodic Maintenance	6-1
6.2	Failure Analysis.....	6-1
CHAPTER 7.	TECHNICAL SPECIFICATIONS.....	7-1
7.1	Introduction.....	7-1
7.2	Input Characteristics	7-1
7.3	Output Characteristics	7-1
7.4	Transfer Characteristics.....	7-1
7.5	Frequency Synthesizer Characteristics.....	7-2
7.6	Single Side Band Phase Noise	7-2
7.7	Operator Interface	7-2
7.7.1	Converter Settings.....	7-3
7.7.2	Switch Settings.....	7-4
7.7.3	LED Indicators.....	7-4
7.8	Physical Characteristics	7-4
7.9	Environmental Characteristics.....	7-4
APPENDIX A.	REMOTE ASCII	A-1
A.1	Control Commands.....	A-1
A.2	Remote Help Menu (All).....	A-2
A.3	Status Command (All)	A-4
A.4	Data (All).....	A-6
A.5	Show Received Signal Strength Command (Upconverter Only) (S, P1:1, P1:8).....	A-7
A.6	Show Priority Command (B1: 8)	A-7

A.7	Set Current Channel Frequency Command (S, P1:1, P1:8)	A-8
A.8	Set Current Channel Gain Command (S, P1:1, P1:8)	A-9
A.9	Channel Command (S, P1:1, P1:8)	A-9
A.10	Set Priority (B1: 8)	A-10
A.11	Store Current Channel Settings (S, P1: 1, P1: 8)	A-11
A.12	RF On/Off Command (Upconverter Only) (All)	A-11
A.13	Change Input Attenuation Command (Upconverter Only) (S, P1: 1, P1: 8)	A-11
A.14	Clear Faults Command (All)	A-12
A.15	Auto Mode Command (P1: 1, B1: 1, B1: 8)	A-12
A.16	Manual Mode Command (P1: 1, B1: 1)	A-12
A.17	Manual Backup Command (B1: 8)	A-13
A.18	Set Stored Gain For a Specified Channel (S, P1: 1, P1: 8)	A-13
A.19	Set Stored Frequency For a Specified Channel (S, P1: 1, P1: 8)	A-13
A.20	Erase (All)	A-14
A.21	Restart (All)	A-14
A.22	Learn (B1: 1, B1: 8)	A-14
A.23	Read DAC Value by Index (All)	A-15
A.24	Write DAC Value by Index (All)	A-15
A.25	Get Gain Offset (Upconverter Only)	A-16
A.26	Set Gain Offset (Upconverter Only)	A-16
A.27	Dump Channel Table (All)	A-16
A.28	Dump Calibration Table Set (All)	A-16
A.29	Get Current DAC Value (All)	A-17
A.30	Get DAC Value for Frequency and Gain (All)	A-17
A.31	Error Messages	A-18
APPENDIX B.	REMOTE RLLP	1

B.1	Converter Opcode Command Set.....	1
B.2	Converter Queries.....	3
	Opcode: <2404H> Query control mode	3
	Opcode: <240EH> Query time.....	3
	Opcode: <240FH> Query date	3
	Opcode: <2410H> Query time and date.....	3
	Opcode: <3000H> Query software revision number	3
	Opcode: <3001H> Query firmware part number and release date.....	4
	Opcode: <3003H> Query converter configuration.....	5
B.3	Switch Queries.....	5
	Opcode: <3010H> Query switch status.....	5
	Opcode: <3011H> Query switch configuration	7
B.4	Converter Commands.....	9
	Opcode: <2600H> Command control mode	9
	Opcode: <2C03H> Command clear latched alarms	9
	Opcode: <2C04H> Command set time	9
	Opcode: <2C05H> Query set date	9
	Opcode: <2C06H> Command set time and date.....	9
	Opcode: <2C0BH> Command set terminal emulation.....	9
	Opcode: <2C0CH> Command set terminal baud rate.....	9
	Opcode: <3020H> Command set frequency for the current channel.....	10
	Opcode: <3021H> Command set gain for the current channel	10
	Opcode: <3022H> Command set frequency for the given channel	10
	Opcode: <3023H> Command set gain for the given channel.....	10
	Opcode: <3024H> Command set channel.....	10
	Opcode: <3025H> Command set carrier control	10
	Opcode: <3026H> Command set input attenuation	10
	Opcode: <3027H> Command set converter alarm masks	10
B.5	Switch Commands	11
	Opcode: <3040H> Command set backup mode.....	11
	Opcode: <3041H> Command force a manual backup	11
	Opcode: <3042H> Command learn converter configuration.....	11
	Opcode: <3043H> Command backup test converter configuration.....	11
	Opcode: <3044H> Command set compensation control.....	11
	Opcode: <3045H> Command set converter compensation	11
	Opcode: <3046H> Command set all converter compensations	12
	Opcode: <3047H> Command set converter priority	12
	Opcode: <3048H> Command set all converter priorities.....	12
	Opcode: <3048H> Command set all converter priorities.....	13
	Opcode: <3049H> Command set switch alarm masks.....	13
	Opcode: <304AH> Command set switch fault delay	13
APPENDIX C.	SNMP MIB	C-1

PREFACE

About this Manual

This manual describes the installation and operation for the Radyne SFC1450A/6400A. This is a technical document intended for earth station engineers, technicians, and operators responsible for the operation and maintenance of the SFC1450A/6400A.

Trademarks

Product names mentioned in this manual may be trademarks or registered trademarks of their respective companies and are hereby acknowledged.

Copyright

©2011, Comtech EF Data This manual is proprietary to Comtech EF Data and is intended for the exclusive use of Comtech EF Data's customers. No part of this document may in whole or in part, be copied, reproduced, distributed, translated or reduced to any electronic or magnetic storage medium without the express written consent of a duly authorized officer of Comtech EF Data

Conventions and References

Related Documents

The following documents are referenced in this manual:

- *INTELSAT Earth Station Standards IESS-308, -309, -310, and -315*

Metric Conversion

Metric conversion information is located on the inside back cover of this manual. This information is provided to assist the operator in cross-referencing non-Metric to Metric conversions.

Cautions and Warnings



WARNING indicates a potentially hazardous situation that, if not avoided, could result in death or serious injury.



CAUTION indicates a hazardous situation that, if not avoided, may result in minor or moderate injury. CAUTION may also be used to indicate other unsafe practices or risks of property damage.



IMPORTANT or **NOTE** indicates a statement associated with the task being performed or information critical for proper equipment function.

Electrical Safety

The SFC1450/SFC6400A has been shown to comply with the **EN 60950-1 Safety of Information Technology Equipment (including electrical business machines)** safety standard.

The equipment is rated for a nominal operating range of 100 - 240 volts AC or an appropriately equipped DC option, nominal operating range is 48+/-5 volts DC . The unit has a maximum power consumption of 250 watts.

Battery



*The Converter contains a Lithium Battery. **DANGER OF EXPLOSION EXISTS** if the battery is incorrectly replaced. Replace only with the same or equivalent type recommended by the manufacturer. Dispose of used batteries in accordance with local and national regulations.*

Grounding



PROPER GROUNDING PROTECTION REQUIRED: *The installation instructions require that the integrity of the protective earth must be ensured and that the equipment shall be connected to the protective earth connection at all times. Therefore, it is imperative during installation, configuration, and operation that the user ensures that the unit has been properly grounded using the ground stud provided on the rear panel of the unit.*

- In Finland: "Laite on liitettävä suojamaadoituskoskettimilla varustettuun pistorasiaan."
- In Norway: "Apparatet må tilkoples jordet stikkontakt."
- In Sweden: "Apparaten skall anslutas till jordat uttag."

Fuses



FOR CONTINUED OPERATOR SAFETY, ALWAYS REPLACE THE FUSES WITH THE CORRECT TYPE AND RATING.

The SFC1450A/SFC6400A has no serviceable fuses.

Environmental

The SFC1450A/SFC6400A must not be operated in an environment where the unit is exposed to precipitation; condensation; humid atmospheres above 95% RH; altitudes (unpressurized) greater than 2000 metres; excessive dust or vibration; flammable gases, corrosive or explosive atmospheres; or extremes of temperature outside the ambient range 0 to +50°C. Maximum storage temperature allowed is -20 to +70°C.

Operation in vehicles or other transportable installations that are equipped to provide a stable environment is permitted. If such vehicles do not provide a stable environment, safety of the equipment to EN 60950 may not be guaranteed.

Installation



PROPER GROUNDING PROTECTION IS REQUIRED – REFER TO THE GROUNDING ‘CAUTION’ NOTE PROVIDED ON THE PREVIOUS PAGE. The SFC1450A/SFC6400A is designed for connection to a power system that has separate ground, line and neutral conductors. The equipment is not designed for connection to a power system that has no direct connection to ground.

The installation and connection to the line supply must be made in compliance to local or national wiring codes and regulations.

The SFC1450A/SFC6400A is shipped with a line inlet cable suitable for use in the country of operation. If it is necessary to replace this cable, ensure the replacement has an equivalent specification. Examples of acceptable ratings for the cable include HAR, BASEC and HOXXX-X. Examples of acceptable connector ratings include VDE, NF-USE, UL, CSA, OVE, CEBEC, NEMKO, DEMKO, BS1636A, BSI, SETI, IMQ, KEMA-KEUR and SEV.

International Symbols			
Symbol	Definition	Symbol	Definition
	Alternating Current		Protective Earth
	Fuse		Chassis Ground

Telecommunications Terminal Equipment Directive

In accordance with the Telecommunications Terminal Equipment Directive 91/263/EEC, this equipment should not be directly connected to the Public Telecommunications Network.

CE Mark

Comtech EF Data declares that the SFC1450A/SFC6400A Converter meets the necessary requirements for the CE Mark.

EMC (Electromagnetic Compatibility)

In accordance with European Directive 2004/108/EEC, the SFC1450A/SFC6400A has been shown, by independent testing, to comply with the following standards:

Emissions: EN 55022 Class B - Limits and methods of measurement of radio interference characteristics of Information Technology Equipment.

(Also tested to FCC Part 15 Class B.)

Immunity: EN 55024 – Information Technology Equipment: Immunity Characteristics, Limits, and Methods of Measurement.

Additionally, the SFC1450A/SFC6400A has been shown to comply with the following standards:

EN 61000-3-2 – Harmonic Currents Emission;

EN 61000-3-3 – voltage Fluctuations and Flicker.



To ensure that the Converter continues to comply with these standards, observe the following instructions:

- Connections to the transmit and receive IF ports should be made using a good quality coaxial cable. For example, RG58 or RG59 for BNC IF connectors.
- All 'D' type connectors attached to the rear panel must have back-shells that provide continuous metallic shielding. Cable with a continuous outer shield (either foil or braid, or both) must be used, and the shield must be bonded to the back-shell.
- The equipment must be operated with its cover on at all times. If it becomes necessary to remove the cover, the user should ensure that the cover is correctly re-fitted before normal operation commences.

Warranty Policy

Comtech EF Data products are warranted against defects in material and workmanship for a period of two years from the date of shipment. During the warranty period, Comtech EF Data will, at its option, repair or replace products that prove to be defective. Repairs are warranted for the remainder of the original two year warranty, or a 90 day extended warranty, whichever is longer.

For equipment under warranty, the owner is responsible for freight to Comtech EF Data and all related customs, taxes, tariffs, insurance, etc. Comtech EF Data is responsible for the freight charges only for return of the equipment from the factory to the owner. Comtech EF Data will return the equipment by the same method (i.e., Air, Express, Surface) as the equipment was sent to Comtech EF Data.

All equipment returned for warranty repair must have a valid RMA number issued prior to return and be marked clearly on the return packaging. Comtech EF Data strongly recommends all equipment be returned in its original packaging.

Comtech EF Data Corporation's obligations under this warranty are limited to repair or replacement of failed parts, and the return shipment to the buyer of the repaired or replaced parts.

Limitations of Warranty

The warranty does not apply to any part of a product that has been installed, altered, repaired, or misused in any way that, in the opinion of Comtech EF Data Corporation, would affect the reliability or detracts from the performance of any part of the product, or is damaged as the result of use in a way or with equipment that had not been previously approved by Comtech EF Data Corporation.

The warranty does not apply to any product or parts thereof where the serial number or the serial number of any of its parts has been altered, defaced, or removed.

The warranty does not cover damage or loss incurred in transportation of the product.

The warranty does not cover replacement or repair necessitated by loss or damage from any cause beyond the control of Comtech EF Data Corporation, such as lightning or other natural and weather related events or wartime environments.

The warranty does not cover any labor involved in the removal and or reinstallation of warranted equipment or parts on site, or any labor required to diagnose the necessity for repair or replacement.

The warranty excludes any responsibility by Comtech EF Data Corporation for incidental or consequential damages arising from the use of the equipment or products, or for any inability to use them either separate from or in combination with any other equipment or products.

A fixed charge established for each product will be imposed for all equipment returned for warranty repair where Comtech EF Data Corporation cannot identify the cause of the reported failure.

Exclusive Remedies

Comtech EF Data Corporation's warranty, as stated is in lieu of all other warranties, expressed, implied, or statutory, including those of merchantability and fitness for a particular purpose. The buyer shall pass on to any purchaser, lessee, or other user of Comtech EF Data Corporation's products, the aforementioned warranty, and shall indemnify and hold harmless Comtech EF Data Corporation from any claims or liability of such purchaser, lessee, or user based upon allegations that the buyer, its agents, or employees have made additional warranties or representations as to product preference or use.

The remedies provided herein are the buyer's sole and exclusive remedies. Comtech EF Data shall not be liable for any direct, indirect, special, incidental, or consequential damages, whether based on contract, tort, or any other legal theory.

Customer Support

Contact the Comtech EF Data Customer Support Department for:

- Product support or training
- Reporting comments or suggestions concerning manuals
- Information on upgrading or returning a product

A Customer Support representative may be reached at:

Comtech EF Data
Attention: Customer Support Department
2114 West 7th Street
Tempe, Arizona 85281 USA
480.333.2200 (Main Comtech EF Data number)
480.333.4357 (Customer Support Desk)
480.333.2161 FAX

To return a Comtech EF Data product (in-warranty and out-of-warranty) for repair or replacement:

- **Contact** the Comtech EF Data Customer Support Department. Be prepared to supply the Customer Support representative with the model number, serial number, and a description of the problem.
- **Request** a Return Material Authorization (RMA) number from the Comtech EF Data Customer Support representative.
- **Pack** the product in its original shipping carton/packaging to ensure that the product is not damaged during shipping.
- **Ship** the product back to Comtech EF Data. (Shipping charges should be prepaid.)

Online Customer Support

An **RMA number request** can be requested electronically by contacting the Customer Support Department through the online support page at **www.comtechefdata.com/support.asp**:

- **Click** on the “Service” hyperlink, then read the “Return Material Authorization” section for detailed instructions on our return procedures.
- **Click** on the “RMA Request Form” hyperlink, then fill out the form completely before sending.
- **Send e-mail** to the Customer Support Department at **service@comtechefdata.com**.

For information regarding this product’s warranty policy, refer to the Warranty Policy, p. xxii.

Chapter 1. INTRODUCTION

1.1 Description

This manual discusses the Comtech EF Data SFC Synthesized Frequency Upconverter family of products (Figure 1-1). These include the SFC6400A C-Band, and the SFC1450A Ku-Band Synthesized Frequency Upconverters. They are high quality, rack mounted satellite Upconverters that are intended for use in medium-to-large earth station installations where multiple carrier uplinks need to be established. The SFC Upconverters are ready to be configured into a variety of backup switch configurations, which include 1:1, and 1:N (to a maximum of N = 8) configurations.



Figure 1-1. SFC1450A Upconverter Front Panel



Figure 1-1. SFC6400A Upconverter Front Panel

The SFC6400A Upconverter is a C-Band, 125 kHz resolution synthesized satellite upconverter capable of converting either a 36 MHz bandwidth, 70 MHz IF input or optionally a 72 MHz bandwidth, 140 MHz input to a C-Band uplink in the range of 5845 - 6425 MHz (5845 - 6650 MHz extended band).

The SFC1450A Upconverter is a Ku-Band 125 kHz resolution synthesized satellite Upconverter capable of converting either a 36 MHz bandwidth, 70 MHz IF input or optionally a 72 MHz bandwidth, 140 MHz input to a Ku-Band uplink in the range of 14.00 - 14.50 GHz (13.75 - 14.50 GHz extended band).

All of the configuration, monitor, and control functions are available at the front panel. Operating parameters such as frequency, channel, gain, gain offset, and switch settings (backup only) can be readily set and changed at the front panel. Additionally, all functions can be accessed with a terminal or personal computer via a serial link (RS-232, RS-485, or Ethernet) for complete remote monitoring and control (M&C) capability. Extensive fault monitoring with masking capability, along with time and date stamped event storage is available.

The units monitor local oscillator (LO) phase-locked loop faults in the converter at all times during operation. If a fault is detected, the converter immediately goes into the Standby Mode. If multiple converters are configured to provide backup protection switching, a summary fault will signal the backup, which will put itself online and restore the failed circuit.

The RF Hardware consists of a broadband synthesizer, a fixed frequency phase locked oscillator, and the first and second converter modules. The broadband synthesizer provides the synthesized local oscillator for the conversion from L-Band to RF output. The LO that tunes from 4.6625 - 5.2425 GHz or 4.480 – 5.285 GHz (SFC6400A), or from 11.98 – 12.73 GHz (SFC1450A) performs this conversion. The second mixer converts the 70 or 140 MHz IF input to L-Band. A fixed frequency First IFLO performs this frequency conversion.

A 20 dB gain control attenuator at the RF output controls the power out of the converter. This attenuator is capable of 0.1 dB resolution through a software linear interpolation of 1 dB calibration values.

The internal IF is converted by the Second Mixer LO to 70 or 140 MHz. The 70/140 MHz IF chain also performs filtering and phase equalization via an all-pass network. The gain calibration process also provides gain slope across all bands to be within the specified ± 0.75 dB. Additional gain compensation due to changes in ambient temperature provide for high gain stability over various operating conditions.

The SFC Upconverters have been designed to provide performance that meets or exceeds all industry standards in effect today for satellite communications earth station frequency converter equipment found worldwide. In addition to providing robust performance, the SFC Upconverters are loaded with features that will provide ease of integration and operation.

1.2 Protection Switch Versatility

Comtech EF Data SFC family of Converter Products feature 'plug-and-play' ease of installation with the RCU101 1:1 or the RCU108 1:8 Redundancy Control Units. All converters can be plugged into the backup slot and assume the role of protection switch controller. The backup converter learns and stores the frequency, gain and channel settings of the primary converters. The backup converter can be operated automatically, in which case an automatic backup of a faulted, online Converter occurs after a user-programmed delay. The Backup may also be operated manually, allowing the user to manually switch in the Backup Unit. The Front Panel controls and indicators provide for automatic/manual configuration, as well as display of online/offline status information. In the event the stored settings of the Primary Converter are changed, the backup converter will notify the user.

All circuits are protected upon installation of the switch and completion of the learning process. This eliminates the need for complicated software configurations that might otherwise leave a circuit vulnerable. Likewise, replacing a failed converter is as simple as plugging in a replacement.

1.3 Chain Switching (Optional)

Chain Switching is available as an option for the SFC6400A and SFC1450A Upconverters. This unit can be delivered with the optional Chain Switching Module in place, or may be purchased separately and installed by the customer (no tools are required). When equipped with this module, in the event of a unit failure (in a 1:1 or 1:N Configuration where N is less than or equal to 8), the Upconverters themselves perform the switching. This eliminates the need for a separate converter protection switch such as the Comtech EF Data RCU101 or RCU108.

Notes:

Chapter 2. Installation

2.1 Installation Requirements

SFC Upconverters are designed to be installed within any standard 19 inch equipment cabinet or rack, and requires 1 Rack Unit (RU) mounting space (1.75 inches, 4.44 cm) vertically and 19 inches (48.26 cm) of depth. Including cabling, a minimum of 20 inches (50.8cm) of rack depth is required. The rear panel is designed to have power enter from the left and cabling enter from the center and right when viewed from the rear of the unit. Data and control cabling can enter from either side. The unit can be placed on a table or suitable stable surface if required.



Before initially applying power to the unit, it is a good idea to disconnect the transmit output from the operating station equipment. This is especially true if the current SFC Upconverter configuration settings are unknown, where incorrect setting could disrupt existing communications traffic.



There are no user-serviceable parts or configuration settings located inside the SFC Upconverter Chassis. There is a potential shock hazard internally at the power supply module. DO NOT open the SFC Chassis under any circumstances.



*The SFC Upconverter contains a Lithium Battery. **DANGER OF EXPLOSION** exists if the battery is incorrectly replaced. Replace only with the same or equivalent type recommended by the manufacturer. Dispose of used batteries in accordance with local and national regulations.*

2.2 Unpacking

The SFC Upconverter was carefully packaged to avoid damage and should arrive complete with the following items for proper installation:

SFC Upconverter Unit
Power Cord, 6 foot with applicable AC Connector (for North America)
Installation and Operation Manual

2.3 Removal and Assembly

SFC Upconverters are shipped fully assembled and do not require removal of the covers for any purpose in installation.

Carefully unpack the unit and ensure that all of the above items are in the carton. If available AC mains power available at the installation site requires a different cordset from the one included in the package, then a suitable and approved cordset (for the country where the equipment is to be installed) will be required before proceeding with the installation.

Should the Power Cable/AC Connector be of the wrong type for the installation, either the cable or the power connector end should be replaced. The power supply itself is designed for universal AC application. See specifications for the appropriate voltages and currents.

2.4 Mounting Considerations

When mounted in an equipment rack, adequate ventilation must be provided. The ambient temperature in the rack should be between 10°C and 35°C, and held constant for best equipment operation. The air available to the rack should be clean and relatively dry.

2.5 Initial Power-Up

Turn the unit 'ON' by placing the rear panel switch (above the power entry connector) to the 'ON' position. Upon initial and subsequent power-ups, the SFC Upconverter will test itself and several of its components before beginning its main Monitor & Control Program. The Event Buffer LED will illuminate and the unit will log setup events upon power-up. This allows the user to tell if there was an accidental power failure or if the power was manually cycled for any reason while the unit was left unattended. These events can be cleared after setup. If any failure is detected, an Alarm LED will illuminate.

Chapter 3. Theory of Operation

3.1 Theory of Operation

The SFC Upconverters have been designed to minimize the amount of hardware in the system while maximizing performance. Spurious performance in the Upconverter is critical and in particular, LO related spurious In-Band is nonexistent.

The SFC Upconverters are double conversion microwave Upconverters. The basic block diagram is shown in Figure 3-1.

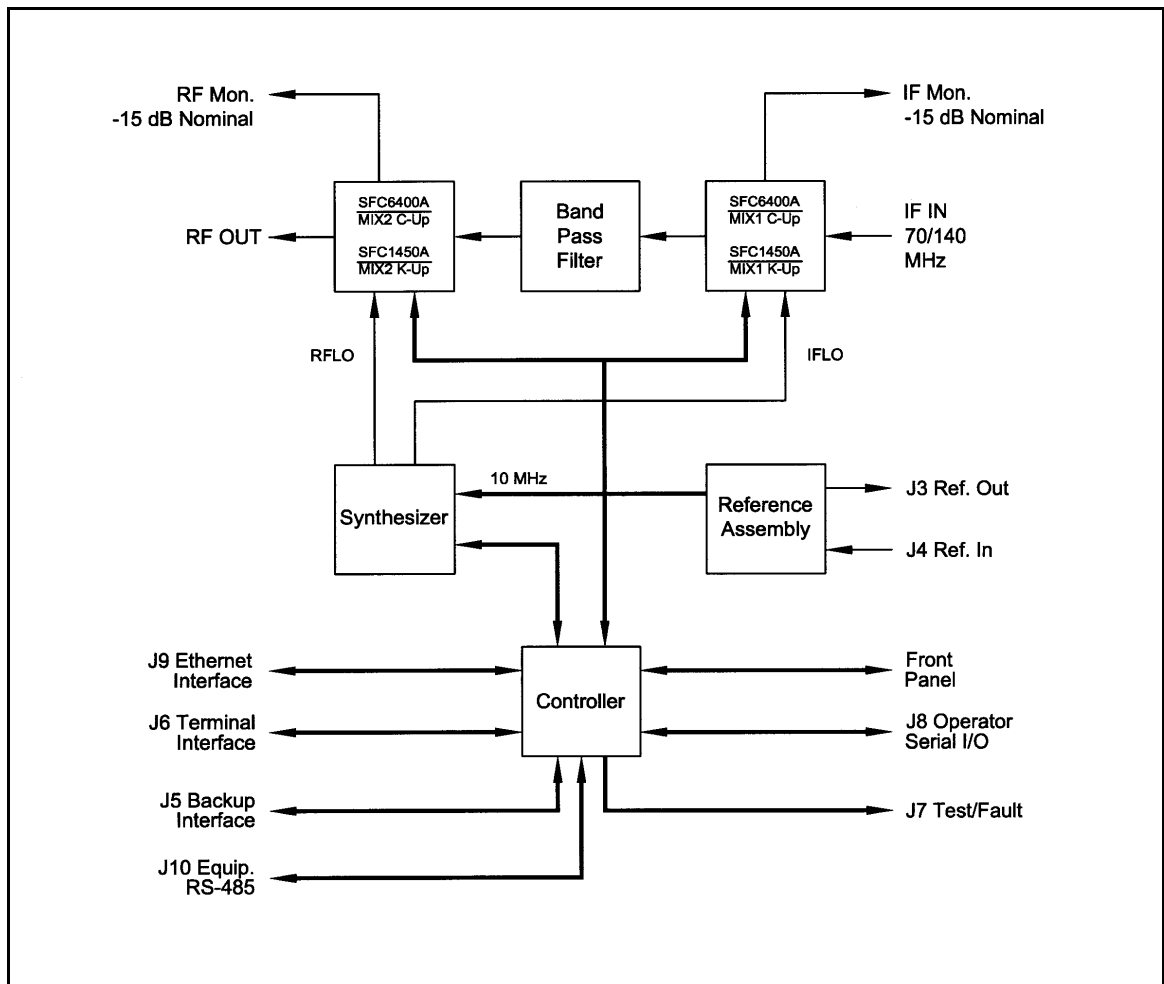

Figure 3-1. SFC Upconverter Block Diagram

3.2 Converter Configuration

There are three basic operating configurations of the SFC Upconverters: Stand-Alone, 1:1 Switch, and 1:8 Switch.

The Upconverter automatically detects the equipment to which it is connected and adjusts its operation accordingly. Some user Menus, most notably the Switch Menu, are only available if the Upconverter is connected as the Backup in a Redundancy Switch System.

Note: The Switch Systems may be referred to as either a Redundancy Switch, a Protection Switch, or simply a Switch. In addition, in all switch configurations, the Backup Unit acts as the master (it controls all switch operations).

3.2.1 Stand-Alone Operation

If J5 on the Back Panel of the SFC Upconverter (B.U. SWITCH INTERFACE) is not connected to a Switch, the unit will automatically configure itself for Stand-Alone Operation. The user can set up all configurable parameters using one of the four different Interfaces described in Section 4.

3.2.2 1:1 Switch

In the case of a 1:1 Switch System, the Upconverter detects to which connector on the Switch it is connected (INTERFACE BACKUP or INTERFACE PRIMARY).

Note: The Primary is also sometimes referred to as the Prime.

If the Converter is connected as the Backup, then all the Switch controls are available to the user on that unit.

Figure 3-2 illustrates a typical interconnection of a SFC Upconverter with an RCU101 1:1 Protection Switch.

3.2.3 1:8 Switch

In a 1:8 Switch, the Converter detects whether it is connected as PRIMARY1 through PRIMARY8, or as the BACKUP. The RCU108 is flexible in that it can be set up with anywhere from 1 through 8 Primary SFC Upconverters. However, there is only one Backup. Thus, only one Prime can be backed up at one time.

Figure 3-3 illustrates a typical interconnection of a SFC Upconverter with an RCU108 1:8 Protection Switch. The configuration shown is a 1:2 Switch.

3.3 Optional Chain Switching Operation

For Chain Switching, each converter in a 1:N configuration (where N is less than or equal to 8) will contain an optional Chain Switching Module. During set up, one of the converters will be considered the backup. This is usually the converter at the bottom of the rack. With no cables connected, each converter will default to standalone operation. Once the system is set up and properly wired, each converter then has an ID Address and can be programmed from the Front Panel to set the priority level of each converter in the rack. If no priority is set from the Front

Panel then the priority will default to level one with the converter closest to the back up having the highest priority and priorities incrementally decreased the further from the backup.

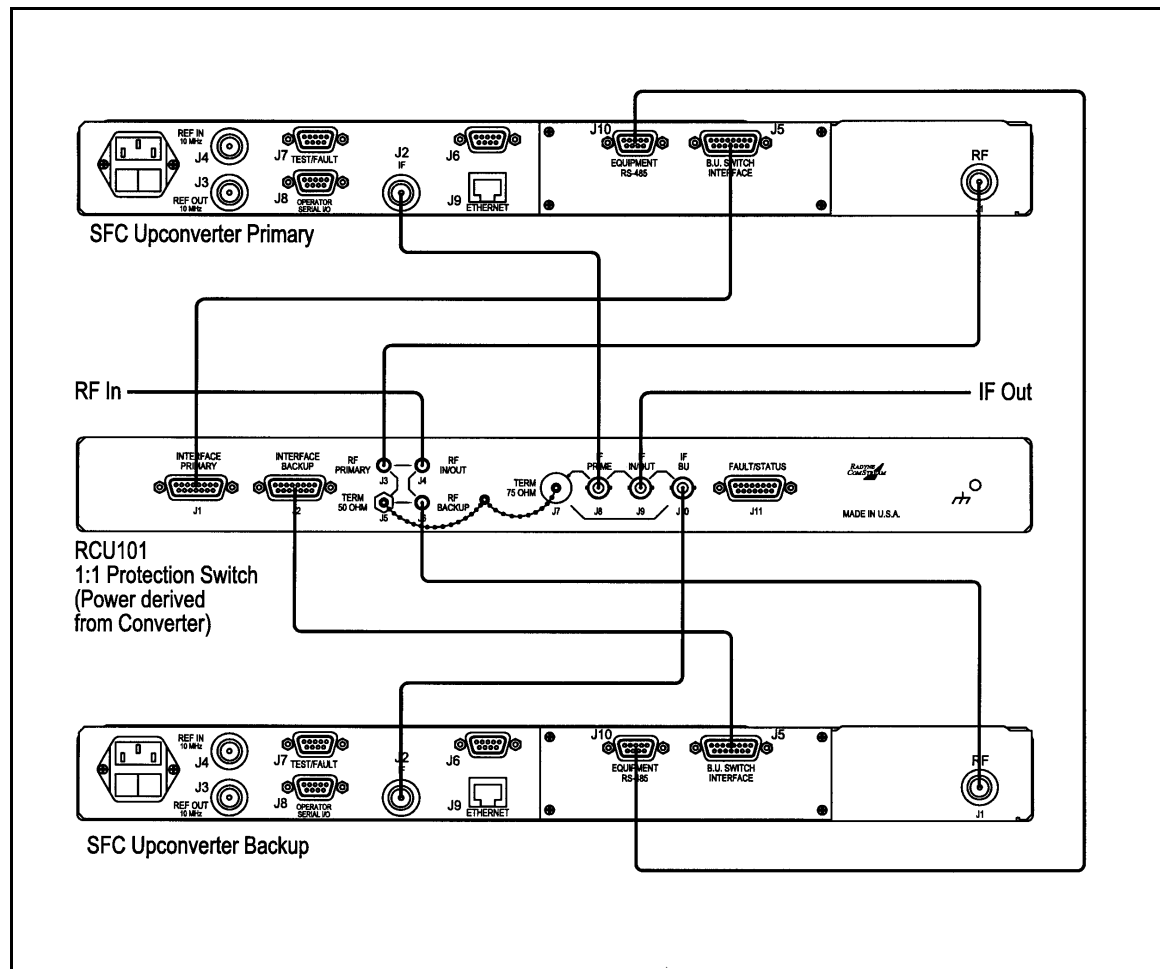

Figure 3-2. RCU101 Typical Interconnection with SFC Upconverters

After all of the converters have been programmed, the back up converter is then set into a “Learn Mode.” The backup polls each converter on a continuous basis and learns and stores the settings of each converter. Because the switch modules are on a common protection bus, each converter knows the address (position in the rack), and the fault status of all of the converters in the rack. In the event of multiple failures, the highest priority converter that fails is backed up first.

The chain switch module provides the primary through path between the converter RF output and the output of the switch module without being powered. It is provided with redundant RF power from all chain switch modules connected in the chain. In the event that an Upconverter needs to be replaced, the Chain Switching Module can be removed from the back of the converter and left in place without breaking the interconnections to adjacent converters in the chain.

Refer to Figure 3-4 for Chain Switching Operation in a 1:1 configuration, and Figure 3-5 for a 1:6 configuration.

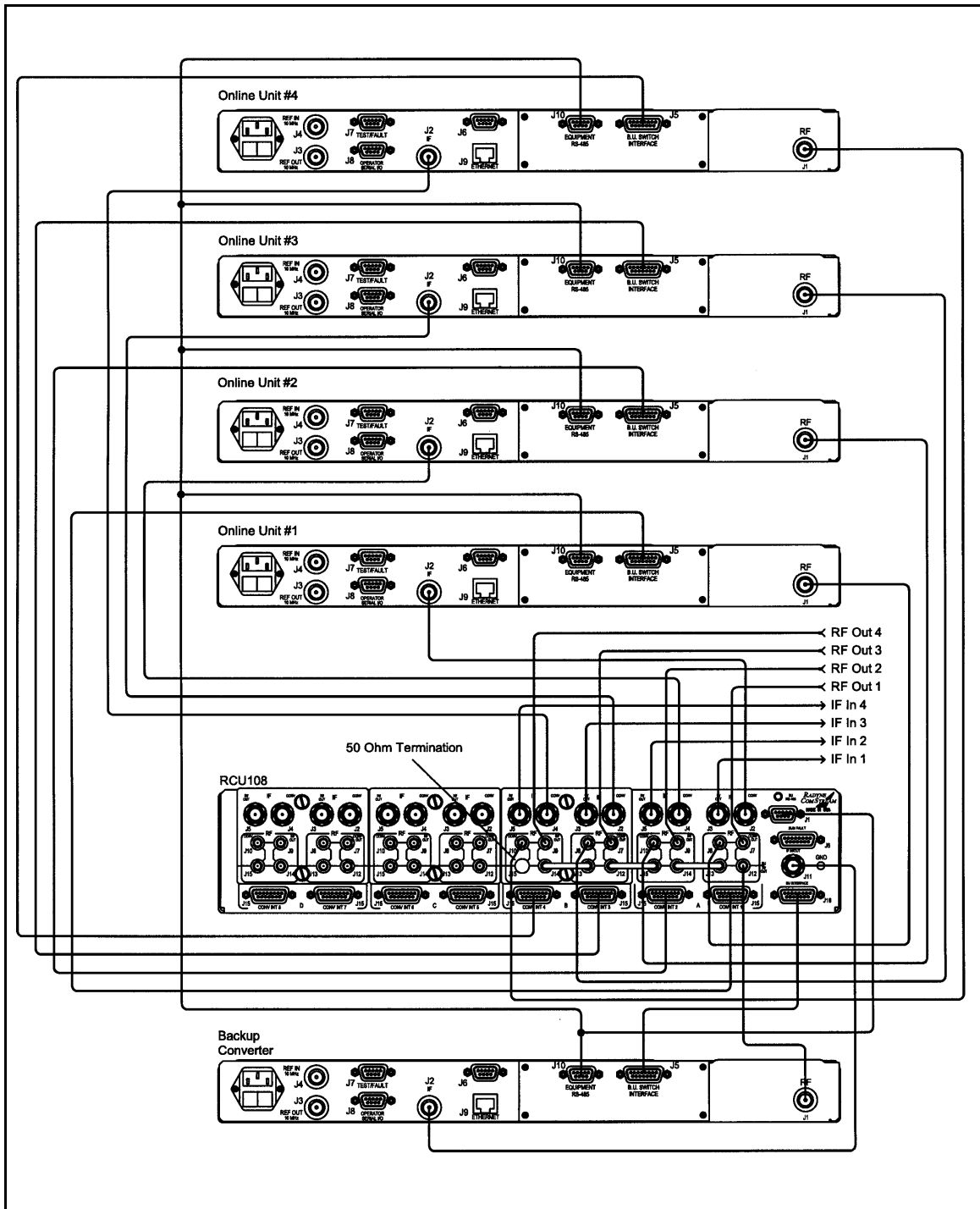

Figure 3-3. RCU108 Typical Interconnection with SFC Upconverters

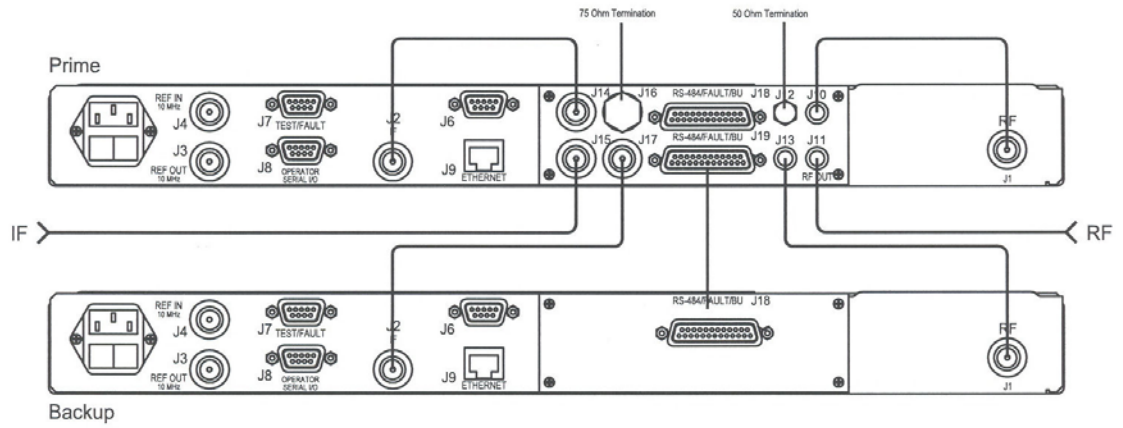

Figure 3-4. Chain Switching Operation in a 1:1 Configuration

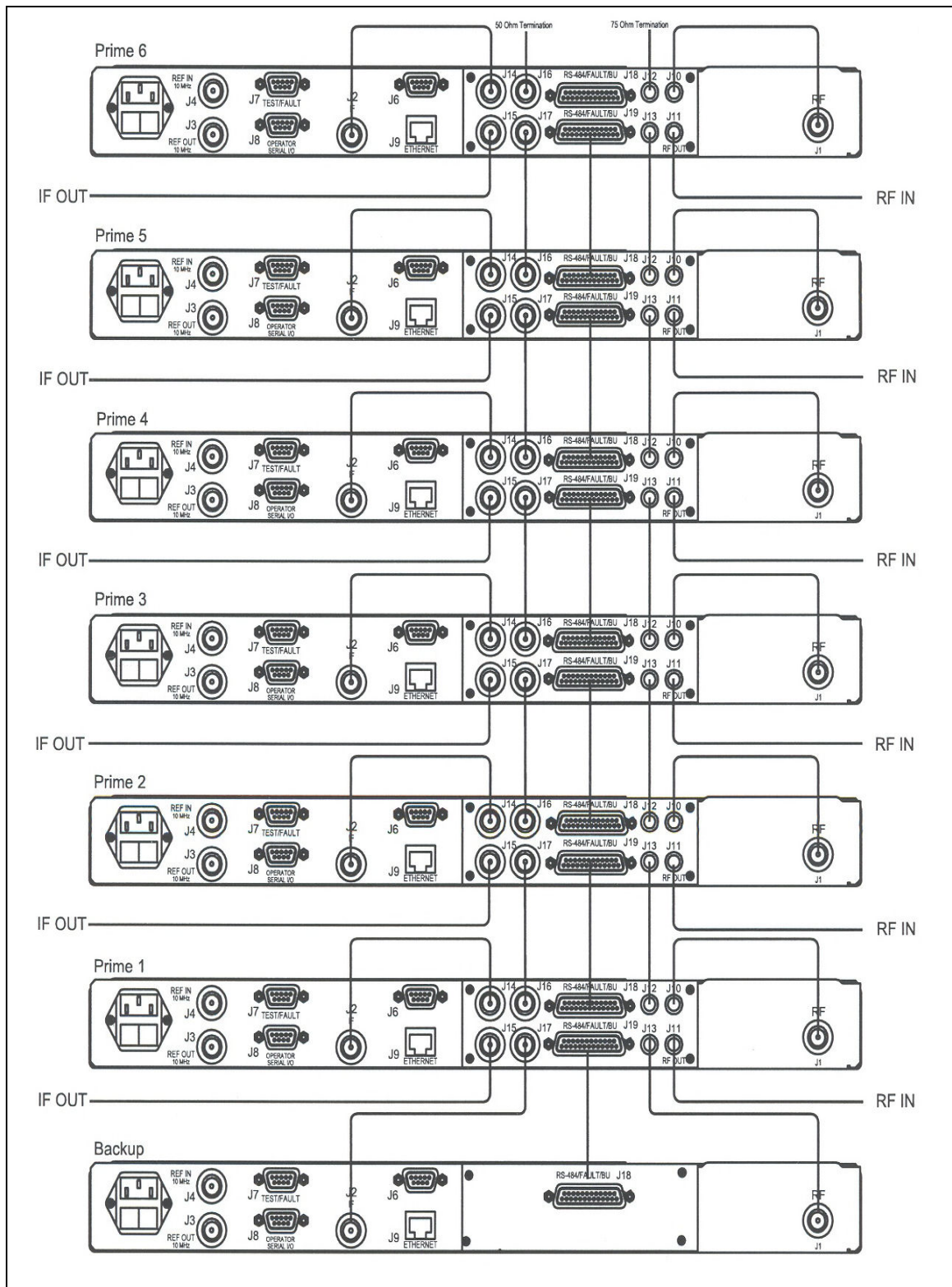

Figure 3-5. Chain Switching Operation in a 1:N Configuration

Chapter 4. Front Panel Interface

4.1 User Interfaces

There are four User Interfaces available for the SFC Upconverter. These are:

- Front Panel
- Remote Port
- Terminal Port
- Ethernet Port

4.2 Front Panel User Interface

The Front Panel of the SFC Upconverters allow for complete monitor and control (including but not limited to operation, calibration, and testing) of all parameters and functions via Monitoring Ports, a Keypad, LCD Display and Status LEDs.

The front panel layout is shown in Figure 4-1, showing the location and labeling of the front panel. The front panel is divided into four functional areas: Monitoring Ports, LCD Display, Cursor Control Arrows, Numeric Keypad, and LED Indicators. Each is described below. Table 4-1 lists each of these areas. They are further described below.

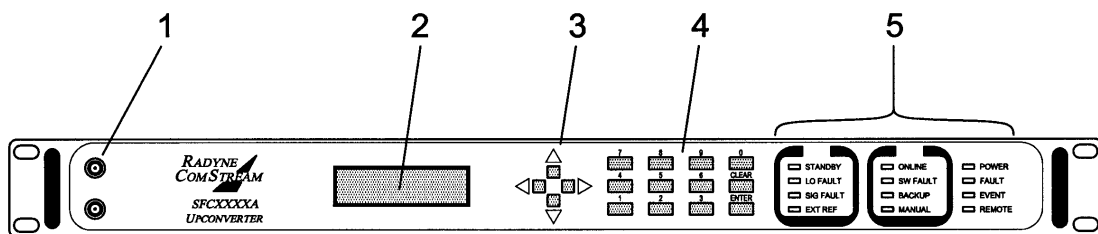

Figure 4-1. SFC Upconverters Front Panel Controls and Indicators

Table 4-1. Front Panel User Interface		
Item No.	Description	Function
1	Monitoring Ports	Allow monitoring of the RF and IF Signals.
2	LCD Display	Displays SFC Upconverter operating parameters and configuration data.
3	Cursor Control Arrows	Controls the left, right, up, and down motion of the cursor in the LCD Display window.
4	Numeric Keypad	Allows entry of numeric data and Clear and Enter Function Keys.
5	LED Indicators	Displays SFC Upconverter operating status.

4.2.1 Monitoring Ports

Refer to Section 5.12.

4.2.2 LCD Display

The front panel display is a 2 line by 16-character LCD display. The display is lighted and the brightness can be set to increase when the front panel is currently in use. The LCD display automatically dims after a period of inactivity. The display has two distinct fields showing current information. The upper field shows the current parameter being monitored, such as 'FREQUENCY (GHz)' or 'CHNL GAIN (dB)'. The lower field shows the current value of that parameter. The LCD display is a single entry window into the large matrix of parameters that can be monitored and set from the front panel.

4.2.3 Cursor Control Arrows

Table 4-2. Cursor Control Arrow Keys	
Key	Function
Left/Right Arrow Keys (→), (←)	The Left/Right Arrow Keys are used to move through the Menu structure. The Left/Right Arrow Keys are also used to move the cursor to a specific digit in a number field. No changes in the values or status can be executed from the left/right cursor movement.
Up/Down Arrow Keys (↑), (↓)	<p>The Down Arrow Key is used to move from a Menu screen to the selections or submenus beneath that Menu. The Up Arrow does the reverse, moving from a submenu or selection to a higher-level Menu.</p> <p>The Up/Down Arrow Keys are also used to change the value of some parameters. Some Menu items, such as SYSTEM<CONTROL MODE, contain a list of possible settings. The Arrow Keys are used to scroll through the list until the desired setting is displayed. Similarly, these keys toggle the ± sign of any signed parameters. <ENTER> is then used to execute the selection.</p> <p>For numerical parameters, such as CONVERTER<FREQUENCY(GHz), the Arrow Keys can be used to scroll through the possible values of each particular digit. The Left/Right Keys are used to move the cursor to the desired digit. To execute a change, <ENTER> must be pressed.</p>

4.2.4 Front Panel Keypad

The front panel keypad consists of two areas: a 10-key numeric entry with 2 additional keys for the 'Enter' and 'Clear' function. The second area is a set of 'Arrow' or 'Cursor' keys (↑), (↓), (→), (←), used to navigate the parameter currently being monitored or controlled. Table 4-3 describes the key functions available at the front panel.

Table 4-3. Front Panel Keypad	
Key	Function
0 to 9	The Number Keys are used to change numeric values in the value field of the LCD display.
CLEAR	If pressed before <ENTER> during a parameter change, the CLEAR Key will cause that parameter to return to its original value.
ENTER	The Enter Key will cause changes to Frequency, Status, and other operator-selected parameters to be executed. It also causes the status of the converter to be saved into non-volatile memory.

4.2.5 LED Indicators

There are twelve (12) LEDs on the SFC Upconverter Front Panel to indicate the operation status (refer to Table 4-3).

Table 4-3. Front Panel LED Indicators		
LED	Color	Function
POWER	Green	When illuminated, indicates the presence of primary power and that the On/Off Switch located on the rear of the chassis is in the On Position.
FAULT	Red	When illuminated, Indicates a common fault (internal hardware).
EVENT	Yellow	When illuminated, indicates that an event (may be a fault or startup sequence) has occurred and is stored in the Event Buffer along with a date/time stamp.
REMOTE	Green	When illuminated, indicates that the converter is in Remote Mode. In this mode, the unit settings can only be modified and controlled via a remote interface.
ONLINE	Green	When illuminated, indicates that the backup converter has been placed online to backup a Prime Converter (backup converter Only).
SW FAULT	Red	When illuminated, indicates that an error has occurred during a Backup Process. (backup converter Only). If a SW Fault does not exist but a Learned or a Backup Test Fault exists, this LED will flash at one-second intervals.
BACKUP	Yellow	Used in Chain Switch configuration only.
MANUAL	Yellow	When illuminated, indicates that the backup converter has been Manually placed Online (backup converter Only).
RF ON	Green	When illuminated, indicates that the converter RF output is active.

	Red	If the Synthesized LO or IFLO System of the converter indicates an out-of-lock condition, the LO Fault LED will illuminate. At this time, the Summary Fault Relay Contacts will latch. If the LO Fault was due to an Intermittent Fault Condition, the LO Fault will flash at one-second intervals, and fault checked may be reset.
SIG FAULT	Yellow	Signal Faults are used in switch configuration to indicate switch status (when in the Backup Mode).
EXT REF	Yellow	This LED illuminates when an external 10 MHz reference signal has been applied to the converter. A LO fault may occur when the external reference is applied or removed. This indicates that a change in the reference has occurred. This fault can be cleared with a soft reset.

4.3 Front Panel Control Screen Menus

The complete set of SFC Upconverter Front Panel Control Screens are contained within the following Main Menus:

4.3.1 Main Menus

Converter Menu Options and Parameters

Switch Menu Options and Parameters

Monitor Menu Options and Parameters

Alarms Menu Options and Parameters

System Menu Options and Parameters

Test Menu Options and Parameters

4.3.2 Converter Menu Options and Parameters

FREQUENCY (GHz):	{5895 – 6425 GHz} C-Band, Normal {5845 – 6650 GHz} C-Band, Extended {6.725 – 7.025 GHz} C-Band, India {14.0 – 14.5 GHz} Ku-Band, Normal {13.75 – 14.50 GHz} Ku-Band, Extended Sets the RF output frequency. The available range depends upon the Converter model.
CHNL GAIN (dB):	{-20.0 to +30.0, dependent upon input attenuation} Sets the Channel Gain in 0.1dB steps.
CARRIER CNTRL:	{ON, OFF} Allows the user to turn the carrier on/off.
INPUT ATTN:	{0 - 30}

Sets the input attenuation in 1 dB steps.

CURRENT CHNNL:**{01 – 30}**

Selects the current channel of the unit. Each channel allows entering of an independent set of parameters (Frequency, Gain, etc.). For example, Channel 1 Frequency might be set to 5.9 GHz and Channel 2 could be set to 6.0 GHz. Any of the other parameters could be different as well. The advantage is that by changing the channel number, a completely different setup can be achieved.

4.3.3 Switch Menu Options and Parameters

This Menu is only available when the Upconverter is connected in a 1:1 or 1:N Switch configuration as the Backup Unit.

BACKUP MODE:**{MANUAL, AUTO-NONREVE, AUTO-REVERTI}**

Sets the Backup Mode of the Switch.

Manual: A Prime Converter can be backed up through manual control only.

Auto-Nonrevertive: A Prime Converter will be backed up if it fails. It will remain backed up until it is manually unbacked.

Auto-Revertive: A Prime Converter will be backed up if it fails. If a second Converter, which has been assigned a higher priority (see Monitor Backup State below) fails, the Switch will unback the first and backup the second Converter. If the first Converter recovers after it has been backed up (i.e., no longer has a fault), and a second Converter fails, the recovered unit will be put back on line and the new faulted unit will be backed up.

FORCE BACKUP <SELECT PRIME>: {PRIME 1 - 8, UNBACK}

When in Manual Backup Mode, this selection will force the selected Prime to be backed up.

Unback will release any Prime that is currently backed up.

LEARN <SELECT PRIME>:**{PRIME 1 - 8, ALL}**

Causes the Backup Unit to "Learn" all the settings of the selected Primes. The Backup Upconverter can only backup a Prime that it has learned. A backup test is performed as the unit is learned.

BACKUP TEST <SELECT PRIME>: {PRIME 1-8, ALL}

Causes the Backup Unit to check the selected primes to determine if they are compatible and therefore capable of being backed up.

- FAULT DELAY:** {00050 - 10000}
Sets the delay between the time a Fault occurs in a Prime Unit and the time it is acknowledged by the Backup. The unit is Milliseconds (ms).
- COMPENSATION:** {ENABLE, DISABLE}
Enables or disables the Compensation control described in Prime Setup below.
- PRIME SETUP:**
- PRIME #:**
- PRIORITY:** {0 - 8}
Sets the switching priority of a Prime Unit. If more than one unit fails at the same time, the higher priority unit will be backed up. Also, if one unit is currently backed up and a second unit with a higher priority fails, the first unit will be unbacked and the second unit will be backed up (but only if Backup Mode is Auto-Revertive, see Backup Mode above). The priority is set as follows:
- 0** = No priority (the Switch will ignore the Upconverter). If at any time a Prime's priority is set to 0, the Backup will purge any learned parameters of that Prime.
- 1** = Highest priority.
- 8** = Lowest priority.
- COMPENSATION:** {- 5.0 - +5.0}
Offsets the gain of the Backup Unit to account for variations in loss through the system. This allows the user to ensure that the signal path of a particular Prime Converter maintains the same output power when backed up.
- MONITOR:**
- BACKUP STATE:** {NONE, PRIME1 - 8}
Reports the current Backup State of the Switch. If no Prime is backed up, then the state is reported as <NONE>. If a unit is currently backed up, then its number is reported.
- HOTSTBY STATE:** {NONE, PRIME1 - 8}
Displays the number of the unit that is currently in Hot Standby. Hot Standby is only active when the Switch Mode is set to Auto (Revertive or Nonrevertive). In this condition, the Prime Converter with the highest assigned priority is put in Hot Standby. This means that the Backup unit is already configured with the same settings as that prime.

PRIME #:	
SUMMARY FAULT:	{PASS, FAIL} Reports the system fault status. This is the summary of all the Major, Minor, and Common Alarms currently present in all the individual Prime Converters.
LEARNED:	{YES, NO} Reports whether the Prime has been learned by the Backup.
BACKUP TEST:	{PASS, FAIL} Reports whether the Prime has passed the Backup Test.
CONFIG CHANGED:	{YES, NO} Reports whether the Prime configuration has changed since being learned by the Backup.
RELAY STATUS:	{ON, OFF} Displays the status of the Prime Unit's corresponding RF Relay in the Switch Unit. 'On' indicates that the Prime is being backed up.

4.3.4 Monitor Menu Options and Parameters

REFERENCE:	{INTERNAL, EXTERNAL} Indicates the reference source of the unit. The SFC Upconverter will detect a valid external reference source when it is connected to J4 on the rear panel and automatically select 'External'. Likewise, when no signal (or a signal not meeting the Reference input specification) is connected to J4, the unit will switch to the 'Internal'. The process is completely automatic, and it is independent of M&C control.
-------------------	--

MON VOLTAGES:

RF DETECTOR V:	Monitors the voltage of the RF Detector.
IF DETECTOR V:	Monitors the voltage of the IF Detector.
DAC ATTEN V:	Monitors the voltage of the Output Attenuator DAC.
VCC1 VOLTAGE:	Displays the voltage of the Controller PCB Microprocessor +5V.
+9V VOLTAGE:	Displays the voltage of the System Supply +9V.
+15V VOLTAGE:	Displays the voltage of the System Supply +15V.
- 15V VOLTAGE:	Displays the voltage of the System Supply -15V.

MON DACS:

MIXER DAC VAL:	Displays the decimal value written to the RF Attenuation DAC. This value is not under user control.
MIXER DAC VOL:	Displays the expected voltage output of the RF Attenuation DAC.

REF DAC VALUE:	Displays the decimal value written to the VCO Reference Control DAC. This value is entered by the user in the TEST\REF OFFSET Menu, and cannot be changed from this Menu.
REFDAC VOLTAGE:	Displays the expected voltage output of the VCO Reference Control DAC.
EVENT BUFF	The Event Buffer stores any faults that occur, including start up procedures, along with a time/date stamp.
PRESS CLR TO ERASE EVENTS:	Pressing the <CLEAR> when this screen is displayed will erase all of the events currently stored in the Event Buffer.

4.3.5 Alarms Menu Options and Parameters

For the alarms listed below, the PASS/FAIL displayed is only an indicator and cannot be changed by the user. The MASK/UNMASKED Field, however, does allow user input. Masking an alarm will cause it to be ignored by the unit if that alarm fails. The LCD will display FAIL, but the unit will otherwise not respond to the Fault. This function can aid in troubleshooting system problems.

ACTIVE ALARMS:

MAJOR:

LO FAULT:	{PASS, FAIL/UNMASKED, MASKED} Reports an alarm when the Synthesizer Module indicates an unlocked condition.
SIGNAL FAULT:	{PASS, FAIL/UNMASKED, MASKED} Reports a failure when there is an IF Detect Fault.
BACKUP FAULT:	{PASS, FAIL/UNMASKED, MASKED} backup converter only. Indicates that a Backup process has failed.
NO BACKUP:	{PASS, FAIL/UNMASKED, MASKED} backup converter only. Indicates that a Faulted Prime could not be backed up.
POLLING FAULT:	{PASS, FAIL/UNMASKED, MASKED} backup converter only. Indicates that an interconverter communication failure has occurred.
RELAY FAULT:	{PASS, FAIL/UNMASKED, MASKED} backup converter only. Indicates that the RF Relay used to switch in the backup is not in its expected state.

MINOR:

LEARNED FAULT:	{PASS, FAIL/UNMASKED, MASKED} backup converter only. Indicates that the Backup could not learn the settings of one or more Prime Converters. The SW Fault will flash at one-second intervals to flag this fault to the user.
-----------------------	--

BKP TEST FAULT: {PASS, FAIL/UNMASKED, MASKED}
backup converter only. Indicates that the Backup has determined, by use of the Backup Test, that it will not be able to backup one or more Prime Converters. The Backup Test is done when the <LEARN> function is initiated. The SW Fault will flash at one-second intervals to flag this fault to the user.

CFG CHGD FAULT: {PASS, FAIL/UNMASKED, MASKED}
backup converter only. Indicates that the configuration of one or more Prime Converters has changed since being learned by the Backup. Note that the Backup continuously monitors the settings of all Prime Units in the system to determine if anything changes. The SW Fault will flash at one-second intervals to flag this fault to the user.

RF DTECT FAULT: {PASS, FAIL/UNMASKED, MASKED}
Indicates a failure when the detected RF input signal falls below a fixed threshold.

IF DTECT FAULT: {PASS, FAIL/UNMASKED, MASKED}
Indicates a failure when the detected IF signal falls below a fixed threshold.

COMMON:

CPLD FAULT: {PASS, FAIL/UNMASKED, MASKED}
Indicates a fault if the Controller PCB Microprocessor reads back an unexpected value from the CPLD. This is a check performed on system power up.

FPGA FAULT: {PASS, FAIL/UNMASKED, MASKED}
Indicates a fault if the Controller PCB microprocessor reads back an unexpected value from the FPGA. This is also a check performed on system power up.

EEPROM FAULT: {PASS, FAIL/UNMASKED, MASKED}
Indicates a fault if the Controller PCB microprocessor reads back an unexpected value from the EEPROM. This is checked on system power-up, but is also monitored during normal operation.

REFERENCE ACT: {PASS, FAIL/UNMASKED, MASKED}
A failure indicates that there is no signal connected to the External Reference input on the back panel. In this condition, the Converter uses the internal reference oscillator.

VCC1 FAULT: {PASS, FAIL/UNMASKED, MASKED}
Indicates a fault if the +5V Supply Voltage of the Controller PCB Microprocessor is outside a fixed range.

+9V FAULT: {PASS, FAIL/UNMASKED, MASKED}
Indicates a fault if the +9V System Supply Voltage is outside a fixed range.

+15V FAULT: {PASS, FAIL/UNMASKED, MASKED}
Indicates a fault if the +15V System Supply Voltage is outside a fixed range.

- 15V FAULT: **{PASS, FAIL/UNMASKED, MASKED}**
Indicates a fault if the -15V system supply voltage is outside a fixed range.

LATCHED ALARM: The Latched Alarm Menu structure is identical to the Active Alarms. However, if any alarm is triggered it will be Latched. For example, if an External Reference is disconnected from the rear panel, an LO Fault will be reported while the LO regains lock. After the LO recovers, even though the Active Alarm no longer reports the alarm, the Latched Alarm will still display <FAIL>. In other words, the alarm was latched.

**CLEAR ALARMS
(ENT = Y, CLR = N):** Pressing <ENTER> will clear all of the Latched Alarms currently stored.

4.3.6 System Menu Options and Parameters

CONTROL MODE: **{FT PANEL, TERMINAL, COMPUTER, ETHERNET}**
Sets the Control Mode of the Upconverter.

DATE: Allows the user to enter the date in DD/MM/YY format.

TIME: Allows the user to enter the time in HH:MM:SS format.

FRONT PANEL:

LEVEL: **{OFF, LOW, MID, HIGH}**
Allows the user to set the backlight intensity of the LCD display.

TIMEOUT: **{00 - 99}**
Allows the user to set the length of inactive time (in seconds) after which the display backlight shuts off automatically. Entering 00 allows the backlight to remain on continuously.

KEY CLICK: **{OFF, ON}**
Allows the user turn an audible key click on/off.

TERMINAL:

TERM. BAUD: **{2400, 9600, 19200}**
Allows the user to set the baud rate for terminal port communication.

EMULATION: **{ADDS VP, VT100, WYSE 50}**
Allows the user to set the terminal emulation mode.

ECHO MODE: **{OFF, ON}**
Allows the user to control whether the input at the terminal is echoed back.

REMOTE PORT:

REMOTE PRTOCOL:	{ASCII, RLLP} Allows the user to set the remote port communication protocol.
REMOTE ADDR:	{32 - 255 RLLP, 1 – 255 ASCII} Allows the user to set the communication address of the remote port.
REMOTE BAUD:	{2400, 9600, 19200} Allows the user to set the baud rate for remote port communication.
ECHO MODE:	{OFF, ON} Allows the user to control whether the input at the terminal is echoed back. Only valid in Remote ASCII Mode.
REMOTE LINE:	{RS-232, RS-485} Sets the interface type of the remote port.

HW/FW CONFIG:

FIRMWARE:	FW/XXXX - - Version Y.YY Displays the revision number of the installed M&C Firmware (where XXXX is the firmware number and Y.YY is the version). FW/XXXX - - 19DEC2002 Displays the revision number and release date of the installed M&C Firmware.
CPLD VERSION:	{x.x} Displays version number of installed CPLD Firmware.
FPGA VERSION:	{x.x} Displays version number of installed FPGA firmware.

HARDWARE:

CONVRTR CONFIG:	{STAND ALONE, PRIMARY 1F1, BACKUP 1F1, PRIMARY 1 - 8 1F8, BACKUP 1F8} Allows the user to indicate the function of the Converter as it is connected in the system. The M&C determines this by reading 4 ID bits through the switch interface (refer to Section 5.10).
CONVERTER ID:	{1 - 11, 15} Displays a decimal version of the binary ID bits described above and in Section 5.10. The individual bits are strapped high or low at the switch. They are decoded as follows.

Decimal ID	Converter Function	System Type
0	Not Used	Not Used
1	Primary 1	1F8
2	Primary 2	1F8
3	Primary 3	1F8
4	Primary 4	1F8
5	Primary 5	1F8
6	Primary 6	1F8
7	Primary 7	1F8
8	Primary 8	1F8
9	Backup	1F8
10	Backup	1F1
11	Primary	1F1
12 – 14	Not Used	Not Used
15	Stand Alone (ID Bits pulled up on Controller Card)	Stand Alone

In a Chain Switch system, the ID bits are described as follows:

Decimal ID	Converter Function
0	Backup
1	Primary 1
2	Primary 2
3	Primary 3
4	Primary 4
5	Primary 5
6	Primary 6
7	Primary 7
8	Primary 8
9-14	Not Used

CONVERTER TYPE:

{DN CONVERTER, UP CONVERTER}

Indicates whether the unit is an Upconverter or a Downconverter. This display will match the text on the Front Panel Overlay.

CONVERTER BAND:

{C-BAND, KU-BAND}

Indicates whether the unit is a C-Band or Ku-Band Converter. This display will match the text on the Front Panel Overlay.

- FREQUENCY TYPE:** {70 MHz, 140 MHz}
Indicates the IF type of the Converter.
- SYNTHESIZER:** {MFS-1191, MFS-448, MFS-459, MFS-544, MFS-881, MFS-474, MFS-4.47, MFS-4.59}
Displays the model number of the unit's installed synthesizer.
The frequency range of each model is given below:

Model	IF LO Frequency	Frequency Range	
		Low	High
MFS 1191	1.7 GHz	11.91GHz	12.73 GHz
MFS 448	1.225 GHz	4.48 GHz	5.355 GHz
MFS 459	1.1125 GHz	4.5925 GHz	5.2425 GHz
MFS 544	1.1125 GHz	5.4475 GHz	5.8675 GHz
MFS 881	2.0 GHz	8.81 GHz	10.68 GHz
MFS 474	1.1125 GHz	4.74 GHz	5.54 GHz
MFS 4_47	1.1125 GHz	4.47 GHz	5.34 GHz
MFS 4_59	1.1125 GHz	4.59 GHz	5.54 GHz

- DEBUG MODE:** Password protected. Enables additional Menus for debugging purposes.
- LOAD DEFAULT:** Password protected. Configures the Converter with a set of default parameters. Refer to Section 4.5 for actual default settings.
- SNMP DEFAULT:** Password protected. Configures the Converter SNMP (Ethernet Interface) settings to default values.

4.3.7 Test Menu Options and Parameters

- REF OFFSET:** {0000 - 4095}
The REF OFFSET field of the Test Menu allows the operator to adjust the frequency of the 10 MHz High Stability Internal Reference and vary the output of the Synthesized RF LO by \pm 999 parts per billion (ppb). One part per billion represents a change of 1 Hz per GHz (1 billion Hz) of output frequency. Thus, each unit of ppb will allow a change in accuracy of the converter of 1×10^{-9} .

The exact frequency of the LO Output can be calculated from the displayed frequency on the converter front panel as follows:

C-Band Upconverter (70 MHz IF)	LO = Tx Freq. - 1182.5 MHz
C-Band Upconverter (140 MHz IF)	LO = Tx Freq. - 1252.5 MHz
C-Band Upconverter Extended (70 MHz IF)	LO = Tx Freq. - 1182.5 MHz
C-Band Upconverter Extended (140 MHz IF)	LO = Tx Freq. - 1365.0 MHz
Ku-Band Upconverter (70 MHz IF)	LO = Tx Freq. - 1770.0 MHz
Ku-Band Upconverter (140 MHz IF)	LO = Tx Freq. - 1840.0 MHz

The RF Monitor output can be measured with a frequency counter of known calibration.

The stability of the 10 MHz Reference is related to the temperature of a 10 MHz crystal inside the unit. A proportionally controlled oven around the crystal maintains the temperature in the oven to 0.1°C. In addition, the precise temperature that the oven maintains has been determined empirically for each crystal during manufacturing. As long as the ambient temperature stays within limits (0 - 50°C) the reference will maintain stability of greater than 1×10^{-8} (refer to Figure 4-2).

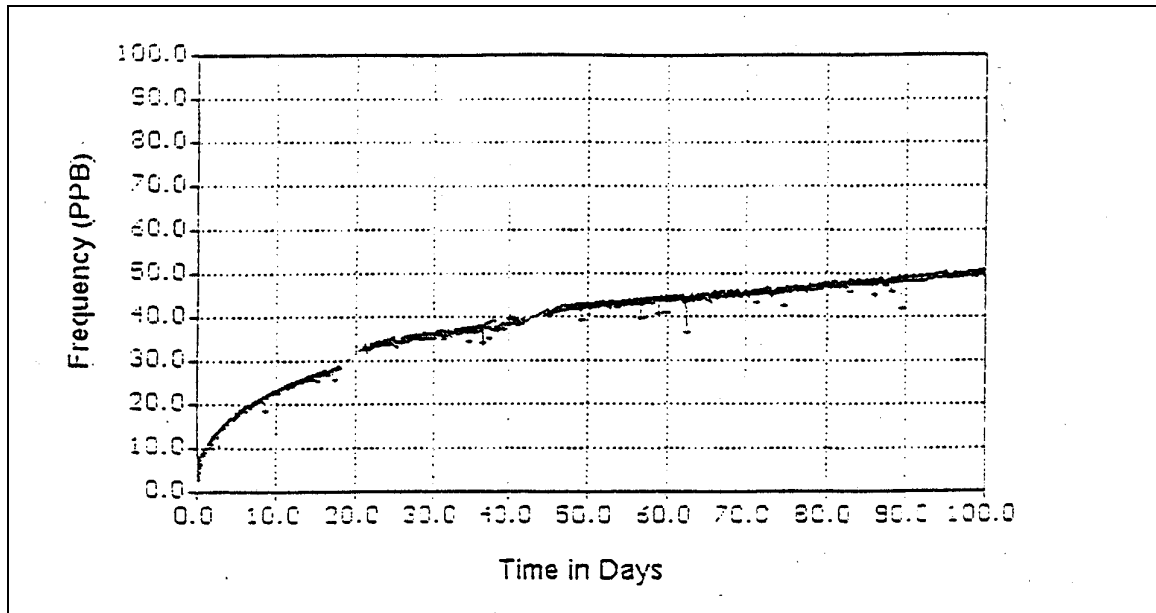

Figure 4-2. Typical Reference Aging vs. Time

Long-term stability of the reference is affected by factors other than temperature. Over days and months, the frequency of the reference will drift at a rate specified as aging. Typical aging rates of 1 to 5 parts in 10^{-10} per day are typical in a crystal that has been stabilized for a few weeks. The first month of operation for any crystal is a time where drift due to aging can be excessive.

The typical aging curve provides insight into the exponential decay in aging rate for a 10 MHz Reference. Converters shipped from the factory have had their reference oscillator aged for a minimum of 30 days and in addition, the aging rate has been verified in the final week to within tolerance. However, converters that have been in storage or powered off for a period of several weeks will exhibit a phenomenon whereby the aging curve return to the slope shown for zero days of aging. This aging reset is not well understood but the manufacturers of crystals believe it to be related to a gradual relaxation of the molecular makeup of the quartz substrates and the conductive films deposited on the quartz.

The rule of thumb when checking the frequency accuracy of the converter is to make sure that the crystal has stabilized before attempting any adjustment. For units that have been in storage or shipment for more than a week, allow several days of operation before verifying the accuracy. For this reason, converters shipped from Comtech EF Data are typically powered-up until the final day before shipment. In addition, the accuracy and aging rate are verified immediately prior to shipment.

For a converter that has been powered-up for several months, the operator can assume an aging rate of several ppb per month. If the aging rate has been established, the station operator can make calculated adjustments from the reference offset Menu at timed intervals.

LED TEST:**{OFF, ON}**

Allows the user to test the function of all front panel LEDs. All of the LEDs will cycle on and off except the Power LED, which is always lit when power is on.

4.4 Examples: Changing Parameters from the Front Panel

4.4.1 Changing Frequency: Numeric Keypad

Note: For this example, it is assumed that the Frequency is currently set to 4 GHz.

1. Upon powering up, the Initializing Screen can be seen on the Front Panel LCD Display for several seconds. This screen indicates the current revision of firmware. Next displayed is one of the following Boot Up Screens.

```
SFC6400A
C-BAND DOWN  <=>
```

```
SFC1450A
KU-BAND DOWN  <=>
```

2. Press and release the Right Arrow Key once. The CONVERTER Menu is displayed.

```
CONVERTER      ↓
(menu)         <=>
```

3. Press and release the Left Arrow Key six (6) times. Notice that the Menu field "wraps" around and ends up at the CONVERTER screen again.
4. Press and release the Down Arrow Key. The FREQUENCY (GHz) Screen is displayed.

```
FREQUENCY(GHz) ↓
6.400000       <=>
```

5. Press and release <ENTER> once. The cursor appears at the lower left corner of the LCD Display.
6. Press and release the Right Arrow Key until the cursor is at the digit to the right of the decimal point. Press and release <2> on the numeric Keypad. The "2" digit now appears at that position and the cursor moves one location to the right.
7. Press and release <ENTER> once. The cursor is no longer visible, and the frequency field now displays "6.400000".

4.4.2 Changing Frequency: Up/Down Arrow Keys

1. Upon powering up, the Boot-Up Screen is shown in the LCD display.
2. Press and release the Right Arrow Key once. The CONVERTER Menu is displayed.
3. Press and release the Down Arrow Key. The FREQUENCY (GHz) Screen is displayed.
4. Press and release <ENTER> once. The cursor appears at the lower left corner of the LCD display.
5. Press and release the Right Arrow Key until the cursor is at the digit to the right of the decimal point. Press the Down Arrow Key until the display shows "05.900000". The cursor is still visible and flashing over the number "9", to the right of the decimal point.
6. Press and release <ENTER> once. The cursor is no longer visible, and the frequency field now displays "5.900000".

FREQUENCY(GHz)	↓
5.900000	↔

7. Press and release <ENTER> once. The cursor appears at the lower left corner of the LCD Display.
8. Press and release the Right Arrow Key until the cursor is at the digit to the right of the decimal point. Press the Up Arrow Key until the display shows "06.000000". The cursor is still visible and flashing over the number "0", to the right of the decimal point.
9. Press and release <ENTER> once. The cursor is no longer visible, and the frequency field now displays "6.000000".

4.4.3 Changing Control Mode to 'TERMINAL'

1. Upon powering up, the Boot-Up Screen is shown in the LCD display.
2. Continue pressing and releasing the Left Arrow Key until the SYSTEM Menu is displayed.
3. Press and release the Down Arrow Key. The CONTROL MODE screen is displayed.

CONTROL MODE	↑
COMPUTER	↔

4. Press and release <ENTER> once. The cursor appears at the lower left corner of the LCD Display.
5. Press and release the Up Arrow Key until the bottom field displays "TERMINAL".
6. Press and release <ENTER> once. The cursor is no longer visible, and the selection has now been changed to "TERMINAL".

```

CONTROL MODE  ↑
TERMINAL      ↔

```

4.4.4 Changing Control Mode Back to 'FT PANEL'

1. Upon powering up, the Boot-Up Screen is shown in the LCD display.
2. Press and release the Right Arrow Key until the SYSTEM Menu is displayed.
3. Press and release the Down Arrow Key. The CONTROL MODE Screen is displayed.
4. Press and release <ENTER> once. The cursor appears at the lower left corner of the LCD Display.
5. Press and release the Up Arrow Key until the bottom field displays "FT PANEL".
6. Press and release <ENTER> once. The cursor is no longer visible, and the selection has now been changed to "FT PANEL".

```

CONTROL MODE  ↑
FT PANEL      ↔

```

4.5 Remote Port User Interfaces

The SFC Upconverter Operator Serial Port allows a remote operator to control the converter. Through the serial protocols (ASCII and RLLP) described below, the remote operator can control gain, frequency, calibration, status, and fault isolation. The connector on the rear panel labeled J8, OPERATOR SERIAL I/O (DB9 Female) is the physical port used for these protocols. It can be configured as either a RS-232 or RS-485 interface. If RS-232 is selected, an adaptor is needed between the converter connector J8 and the remote controller. See Section 5.9 for detailed pinout information. The port is factory-set to communicate as the DCE (Data Communications Equipment) with the following settings:

```

9600 baud
8 data bits
1 start bit
1 stop bit
no parity

```

The serial protocol is designed to provide DTE-to-DCE Point-to-Point Communications. The converter is wired as the DCE to provide an interface to a dumb terminal (DTE) without a null modem connection. Because the serial protocol uses unique addressable commands, the converters are capable of providing multipoint communications between a number of converters and a customer-supplied serial interface. The typical multipoint communications configurations include full-and half-duplex RS-485. In addition, a multipoint RS-232 interface is also possible.

The theory of operation for multipoint requires that the M&C Computer Transmit Port be connected in parallel to all of the Receive Data Ports of the various converters. Likewise, the transmit ports of the various converters must all be connected in parallel and tied to the Receive Data Port of the M&C Computer. To prevent any one Converter Transmit Port from acting as a low impedance, thus hanging the bus, each transmit port of each converter remains in a high impedance state until asked by the M&C computer to transmit.

To prevent data collisions from all the converters responding at once, each converter must be software configured for 'echo off' in the Configuration Menu. If the converters are being linked to a dumb terminal, the echo should be turned on locally.

4.5.1 ASCII Serial Protocol

The ASCII serial protocol serves as a 'wrapper' for the M&C data.

4.5.1.1 ASCII Command Structure

This serial command structure uses an ASCII character string format that enables serial control through the use of a 'dumb terminal.' To differentiate a proper command string from noise, all serial commands have a header followed by the specific command characters, followed by numeric values where required, and are terminated by a character return <cr>. The basic command structure is as follows:

@{Unit Address/}{Command}{Numerical Value(s)}<cr>

For the following examples, a unit address of 01 is assumed.

Refer to Appendix A for Remote ASCII Commands.

4.5.2 RLLP Serial Protocol

The Comtech EF Data Link Level Protocol (RLLP) is an alternative serial protocol used in conjunction with the remote port.

4.5.2.1 RLLP Protocol Structure



When new features are added to Comtech EF Data equipment, the control parameters are appended to the end of the Non-Volatile Section of the Remote Communications Specification, and status of the features, if any, are added at the end of the Volatile Section. If a remote M&C queries two pieces of Comtech EF Data equipment with different revision software, they could respond with two different sized packets. The remote M&C **MUST** make use of the non-volatile count value to index to the start of the Volatile Section. If the remote M&C is not aware of the newly added features to the product, it should disregard the parameters at the end of the Non-Volatile Section and index to the start of the Volatile Section.

Before creating any software based on the information contained in this document, contact the Comtech EF Data Customer Service Department (480-333-4357) to find out if the software revision for that piece of equipment is current and that no new features have been added since the release of this document.

The Communications Specification (COMMSPEC) defines the interaction of computer resident Monitor and Control software used in satellite earth station equipment such as modems, redundancy switches, multiplexers, and other ancillary support gear. Communication is bi-directional, and is normally established on one or more full-duplex multi-drop control buses that conform to EIA Standard RS-485.

Each piece of earth station equipment on a control bus has a unique physical address, which is assigned during station setup/configuration or prior to shipment. Valid decimal addresses on one control bus range from 032 - 255 for a total of up to 224 devices per bus. Address 255 of each control bus is usually reserved for the M&C computer.

4.5.2.2 RLLP Protocol Wrapper

The Comtech EF Data COMMSPEC is byte-oriented, with the Least Significant Bit (LSB) issued first. Each data byte is conveyed as mark/space information with two marks comprising the stop data. When the last byte of data is transmitted, a hold comprises one steady mark (the last stop bit). To begin or resume data transfer, a space substitutes this mark. This handling scheme is controlled by the hardware and is transparent to the user. A pictorial representation of the data and its surrounding overhead may be shown as follows:

S1	S2	B ₀	B ₁	B ₂	B ₃	B ₄	B ₅	B ₆	B ₇	S1	S2, etc.
----	----	----------------	----------------	----------------	----------------	----------------	----------------	----------------	----------------	----	-------------

The stop bits, S1 and S2, are each a mark. Data flow remains in a hold mode until S2 is replaced by a space. If S2 is followed by a space, it is considered a start bit for the data byte and not part of the actual data (B₀ - B₇).

The COMMSPEC developed for use with the Comtech EF Data Link Level Protocol (RLLP) organizes the actual monitor and control data within a shell, or "protocol wrapper", that surrounds the data. The format and structure of the COMMSPEC message exchanges are described herein. Decimal numbers have no suffix; hexadecimal numbers end with a lower case h suffix and binary values have a lower case b suffix. Thus, 22 = 16h = 000010110b. The principal elements of a data frame, in order of occurrence, are summarized as follows:

<SYN> - the message format header character, or ASCII sync character, that defines the beginning of a message. The <SYN> character value is always 16h.

<BYTE COUNT> - the Byte Count is the number of bytes in the <DATA> field, ranging from 0 - TBD.

<SOURCE ID> - the Source Identifier defines the message originator's multidrop address. Note that all nodes on a given control bus have a unique address that must be defined.

<DESTINATION ID> - The Destination Identifier specifies the multidrop address of the device(s) to which the message is sent.

<FRAME SEQUENCE NUMBER> - The FSN is a tag with a value from 0 - 255 that is sent with each message. It assures sequential information framing and correct equipment acknowledgment and data transfers.

<OPCODE> - The Operation Code field contains a number that identifies the message type associated with the data that follows it. Acknowledgment and error codes are returned in this field. This field is 2 Bytes for the SFC6400A/SFC1450A protocol.

<...DATA..> - The Data field contains the binary, data bytes associated with the <OPCODE>. The number of data bytes in this field is indicated by the <BYTE COUNT> value.

<CHECKSUM> - The checksum is the modulo 256 sum of all preceding message bytes, excluding the <SYN> character. The checksum determines the presence or absence of errors within the message. In a message block with the following parameters, the checksum is computed as shown below in Table 4-4.

Table 4-4. Checksum Calculation Example		
BYTE FIELD	DATA CONTENT	RUNNING CHECKSUM
<BYTE COUNT> (Byte 1)	00h = 00000000b	00000000b
<BYTE COUNT> (Byte 2)	02h = 00000010b	00000010b
<SOURCEID>	F0h = 11110000b	11110010b
<DESTINATION ID>	2Ah = 00101010b	00011100b
<FSN>	09h = 00001001b	00100101b
<OPCODE> (Byte 1)	00h = 00000000b	00101000b
<OPCODE> (Byte 2)	03h = 00000011b	00101000b
<DATA> (Byte 1)	DFh = 11011111b	00000111b
<DATA> (Byte 2)	FEh = 11111110b	00000101b

Thus, the checksum is 00000101b; which is 05h or 5 decimal. Alternative methods of calculating the checksum for the same message frame are:

$$00h + 02h + F0h + 2Ah + 09h + 00h + 03h + DFh + FEh = 305h.$$

Since the only concern is the modulo 256 (modulo 100h) equivalent (values that can be represented by a single 8-bit byte), the checksum is 05h.

For a decimal checksum calculation, the equivalent values for each information field are:

$$0 + 2 + 240 + 42 + 9 + 0 + 3 + 223 + 254 = 773;$$

$$773/256 = 3 \text{ with a remainder of } 5. \text{ This remainder is the checksum for the frame.}$$

$$5 \text{ (decimal)} = 05h = 0101b = \text{<CHECKSUM>}$$

4.5.2.3 Frame Description and Bus Handshaking

In a Monitor and Control environment, every message frame on a control bus port executes as a packet in a loop beginning with a wait-for-SYN-character mode. The remaining message format header information is then loaded, either by the M&C computer or by a subordinate piece of equipment requesting access to the bus. Data is processed in accordance with the OPCODE, and the checksum for the frame is calculated. If the anticipated checksum does not match then the wait-for-SYN mode goes back into effect. If the OPCODE resides within a command message, it defines the class of action that denotes an instruction that is specific to the device type, and is a prefix to the DATA field if data is required. If the OPCODE resides within a query message packet, then it defines the query code, and can serve as a prefix to query code DATA.

The Frame Sequence Number (FSN) is included in every message packet, and increments sequentially. When the M & C computer or bus-linked equipment initiates a message, it assigns the FSN as a tag for error control and handshaking. A different FSN is produced for each new message from the FSN originator to a specific device on the control bus. If a command packet is sent and not received at its intended destination, then an appropriate response message is not received by the packet originator. The original command packet is then re-transmitted with the same FSN. If the repeated message is received correctly at this point, it is considered a new message and is executed and acknowledged as such.

If the command packet is received at its intended destination but the response message (acknowledgment) is lost, then the message originator (usually the M&C computer) re-transmits the original command packet with the same FSN. The destination device detects the same FSN and recognizes that the message is a duplicate, so the associated commands within the packet are not executed a second time. However, the response packet is again sent back to the source as an acknowledgment in order to preclude undesired multiple executions of the same command.

To reiterate, valid equipment responses to a message require the FSN tag in the command packet. This serves as part of the handshake/acknowledge routine. If a valid response message is absent, then the command is re-transmitted with the same FSN. For a repeat of the same command involving iterative processes (such as increasing or decreasing transmit power level), the FSN is incremented after each message packet. When the FSN value reaches 255, it overflows and begins again at zero.

The full handshake/acknowledgment involves a reversal of source and destination ID codes in the next message frame, followed by a response code in the <OPCODE> field of the message packet from the equipment under control.

4.5.2.4 Global Response Operational Codes

In acknowledgment response packets, the operational code <OPCODE> field of the message packet is set to 0 by the receiving devices when the message intended for the device is evaluated as valid. The device that receives the valid message then exchanges the <SOURCE ID> with the <DESTINATION ID>, sets the <OPCODE> to zero in order to indicate that a good message was received, and returns the packet to the originator. This "GOOD MESSAGE" Opcode is one of nine global responses. Global response Opcodes are common responses, issued to the M&C computer or to another device, that can originate from and are interpreted by all Comtech EF Data equipment in the same manner. These are summarized as follows all Opcode values are expressed in decimal form:

RESPONSE OPCODE DESCRIPTION	OPCODE
Good Message	0000h
Bad Parameter	00FFh
Bad Opcode	00FEh
Bad Checksum	00FDh
Command Not Allowed in LOCAL Mode	00FCh
Command Not Allowed in AUTO Mode	00FBh
Bad Destination	00FAh
Unable to Process Command	00F9h
Packet Too Long	00F8h

The following response error codes are specific to the SFC Upconverters:

SFC6400A/SFC1450A Response Error Code Descriptions	OPCODE
REMOTE_ERROR_CONTROL_MODE	0203h
REMOTE_ERROR_BAD_PARAMETER	0204h
REMOTE_ERROR_INVALID_TIME	0205h
REMOTE_ERROR_INVALID_DATE	0206h
REMOTE_ERROR_RANGE	0220h
REMOTE_ERROR_RANGE_LO	0221h
REMOTE_ERROR_RANGE_HI	0222h
REMOTE_ERROR_PRIME_NOTPRESENT	0223h
REMOTE_ERROR_PRIME_NOTLEARNED	0224h
REMOTE_ERROR_PRIME_NOTASSIGNED_A_BACKUP	0225h
REMOTE_ERROR_BACKUP_IN_MANUAL_MODE	0226h
REMOTE_ERROR_BACKUP_IN_AUTOMATIC_MODE	0227h
REMOTE_ERROR_IS_DOWN_CONVERTER	0228h
REMOTE_ERROR_IS_UP_CONVERTER	0229h
REMOTE_ERROR_IS_C_BAND_CONVERTER	022Ah
REMOTE_ERROR_IS_KU_BAND_CONVERTER	022Bh
REMOTE_ERROR_IS_KA_BAND_CONVERTER	022Ch
REMOTE_ERROR_INCOMPATIBLE_BAND	022Dh
REMOTE_ERROR_INCOMPATIBLE_TYPE	022Eh
REMOTE_ERROR_CHAIN_CARD_NOTPRESENT	022Fh
REMOTE_ERROR_INVALID_ENTRY	0240h
REMOTE_ERROR_INVALID_FREQUENCY	0241h
REMOTE_ERROR_INVALID_FREQUENCY_STEP	0242h
REMOTE_ERROR_INVALID_PRIME	0243h
REMOTE_ERROR_INVALID_COMPENSATION	0244h
REMOTE_ERROR_INVALID_PRIORITY	0245h
REMOTE_ERROR_INVALID_CHANNEL	0246h
REMOTE_ERROR_INVALID_GAIN	0247h

4.5.2.5 Collision Avoidance

When properly implemented, the physical and logical devices and ID addressing scheme of the COMMSPEC normally precludes message packet contention on the control bus. The importance of designating unique IDs for each device during station configuration cannot be overemphasized. One pitfall, which is often overlooked, concerns multi-drop override IDs. All too often, multiple devices of the same type are assigned in a direct-linked "single-thread" configuration accessible to the M&C computer directly. For example, if two [Converters](#) with different addresses DESTINATION IDs are linked to the same control bus at the same hierarchical level, both will attempt to respond to the M&C computer when the computer generates a multi-drop override ID of 1. If their actual setup parameters, status, or internal timing differs, they will both attempt to respond to the override simultaneously with different information, or asynchronously in their respective message packets and response packets, causing a collision on the serial control bus.

To preclude control bus data contention, different IDs must always be assigned to the equipment. If two or more devices are configured for direct-linked operation, then the M&C computer and all other devices configured in the same manner must be programmed to inhibit broadcast of the corresponding multi-drop override ID.

The multi-drop override ID is always accepted by devices of the same type on a common control bus, independent of the actual DESTINATION ID. These override IDs with the exception of "BROADCAST" are responded to by all directly linked devices of the same type causing contention on the bus. The "BROADCAST" ID, on the other hand, is accepted by all equipment but none of them returns a response packet to the remote M&C.

Table 4-6. Broadcast IDs	
Directly-Addressed Equipment	Multi-Drop Override ID
Broadcast all directly-linked devices	00
DMD-3000/4000, 4500 or 5000 Mod Section, DMD15	01
DMD-3000/4000, 4500 or 5000 Demod Section, DMD15	02
RCU-340 1:1 Switch	03
RCS-780 1:N Switch	04
RMUX-340 Cross-Connect Multiplexer	05
CDS-780 Clock Distribution System	06
SOM-340 Second Order Multiplexer	07
DMD-4500/5000 Modulator Section	08
DMD-4500/5000 Demodulator Section	09
RCU-5000 M:N Switch	10
DMD15 Modulator	20
DMD15 Demodulator	21
DMD15 Modem	22
DVB3030 Video Modulator, DM240	23
Reserved for future equipment types	24 – 31

The following multi-drop override IDs are device-type specific, with the exception of "BROADCAST". These are summarized in Table 4-6 with ID values expressed in decimal notation:

Multi-drop override ID 01 can be used interchangeably to broadcast a message to a DMD-3000/4000 modem, a DMD-4500/5000, a DMD15 modem, or a DVB3030. Comtech EF Data recommends that the multi-drop override IDs be issued only during system configuration as a bus test tool by experienced programmers, and that they not be included in run-time software. It is also advantageous to consider the use of multiple bus systems where warranted by a moderate to large equipment complement.

Therefore, if a DMD15 Modulator is queried for its equipment type identifier, it will return a "20" and DMD15 Demodulator will return a "21". A DMD15 Modem will also return a "22". A DVB3030 Video Modulator will return a "23."

4.5.2.6 Software Compatibility

The COMMSPEC, operating in conjunction within the RLLP shell, provides for full forward and backward software compatibility independent of the software version in use. New features are appended to the end of the DATA field without OPCODE changes. Older software simply discards the data as extraneous information without functional impairment for backward compatibility.

If new device-resident or M&C software receives a message related to an old software version, new information and processes are not damaged or affected by the omission of data.

The implementation of forward and backward software compatibility often, but not always, requires the addition of new Opcodes. Each new function requires a new Opcode assignment if forward and backward compatibility cannot be attained by other means.

When Comtech EF Data equipment is queried for bulk information (Query Mod, Query Demod, etc.) it responds by sending back two blocks of data; a Non-Volatile Section (parameters that can be modified by the user) and a Volatile Section (status information). It also returns a count value that indicates the size of the Non-Volatile Section. This count is used by M&C developers to index into the start of the Volatile Section.

When new features are added to Comtech EF Data equipment, the control parameters are appended to the end of the Non-Volatile Section, and status of the features, if any, are added at the end of the Volatile Section. If a remote M&C queries two pieces of Comtech EF Data equipment with different revision software, they may respond with two different sized packets. The remote M&C MUST make use of the non-volatile count value to index to the start of the Volatile Section. If the remote M&C is not aware of the newly added features to the Comtech EF Data product, it should disregard the parameters at the end of the Non-Volatile Section and index to the start of the Volatile Section.

If packets are handled in this fashion, there will also be backward-compatibility between Comtech EF Data equipment and M&C systems. Remote M&C systems need not be modified every time a feature is added unless the user needs access to that feature.

4.5.2.7 RLLP Summary

The RLLP is a simple send-and-wait protocol that automatically re-transmits a packet when an error is detected, or when an acknowledgment (response) packet is absent.

During transmission, the protocol wrapper surrounds the actual data to form information packets. Each transmitted packet is subject to time out and frame sequence control parameters, after which the packet sender waits for the receiver to convey its response. Once a receiver verifies that a packet sent to it is in the correct sequence relative to the previously received packet, it computes a local checksum on all information within the packet excluding the <SYN> character and the <CHECKSUM> fields. If this checksum matches the packet <CHECKSUM>, the receiver processes the packet and responds to the packet sender with a valid response (acknowledgment) packet.

The response packet is therefore either an acknowledgment that the message was received correctly. If the sender receives a valid acknowledgment (response) packet from the receiver, the <FSN> increments and the next packet is transmitted as required by the sender.

If an acknowledgment (response) packet is lost, corrupted, or not issued due to an error and is thereby not returned to the sender, the sender re-transmits the original information packet; but with the same <FSN>. When the intended receiver detects a duplicate packet, the packet is acknowledged with a response packet and internally discarded to preclude undesired repetitive executions. If the M&C computer sends a command packet and the corresponding response packet is lost due to a system or internal error, the computer times out and re-transmits the same command packet with the same <FSN> to the same receiver and waits once again for an acknowledgment.

Refer to Appendix B for Remote RLLP.

4.6 Terminal Port User Interface

The Terminal Port allows for complete control and monitoring of all Upconverter parameters and functions via an RS-232 Serial Interface. Terminal Mode' can be entered from the front panel by selecting 'System' and then 'Control Mode' followed by 'Terminal.' The default settings for the terminal are as follows:

```
VT100
9600 baud
8 data bits
no parity
1 stop bit
```

These settings can be changed at the front panel by using the *System>Terminal>* Menu.

The Terminal Control Mode is Menu-driven and the allowable values for each item number will be shown. To change an item, type in its number followed by <ENTER>. If the parameter to be changed requires a numeric value, enter the number followed by <ENTER>. If the parameter is non-numeric, press <SPACE> to cycle through the list of available entries. Note that the items that do not have ID numbers are Status only and cannot be changed. Unless otherwise indicated, all terminal Menu items shown below are identical to those described in Section 4.1.6 (LCD Display Menus) above.

4.6.1 Terminal Main Menu

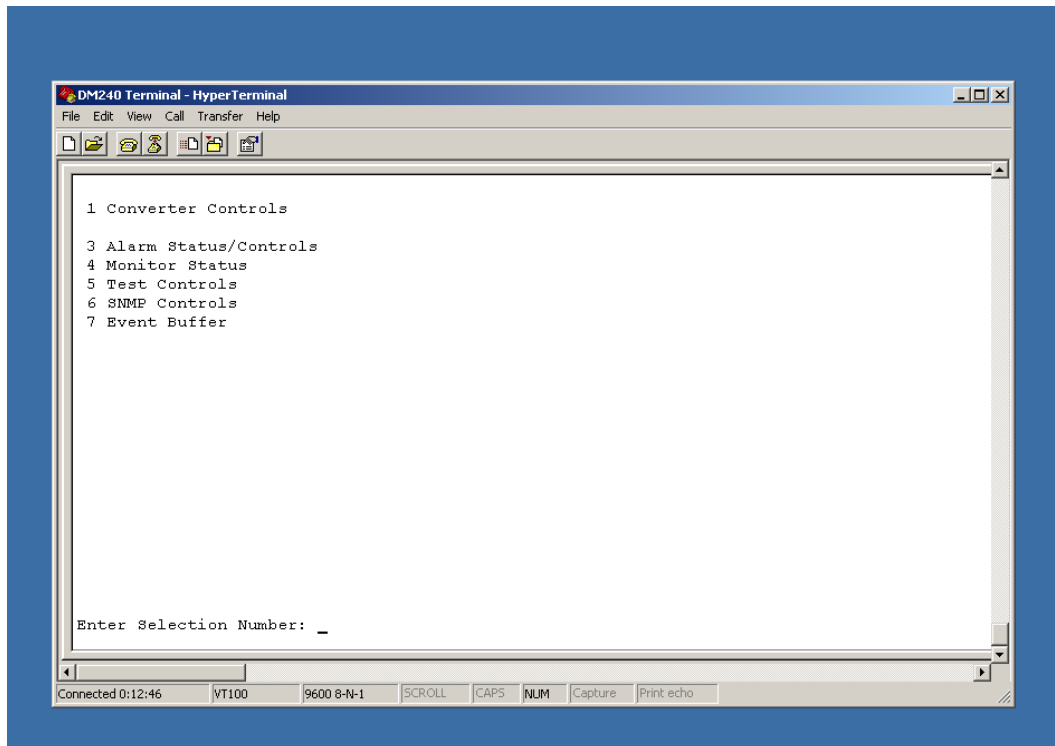

*Menu is available only for a backup converter.

4.6.2 Terminal Converter Controls Menu

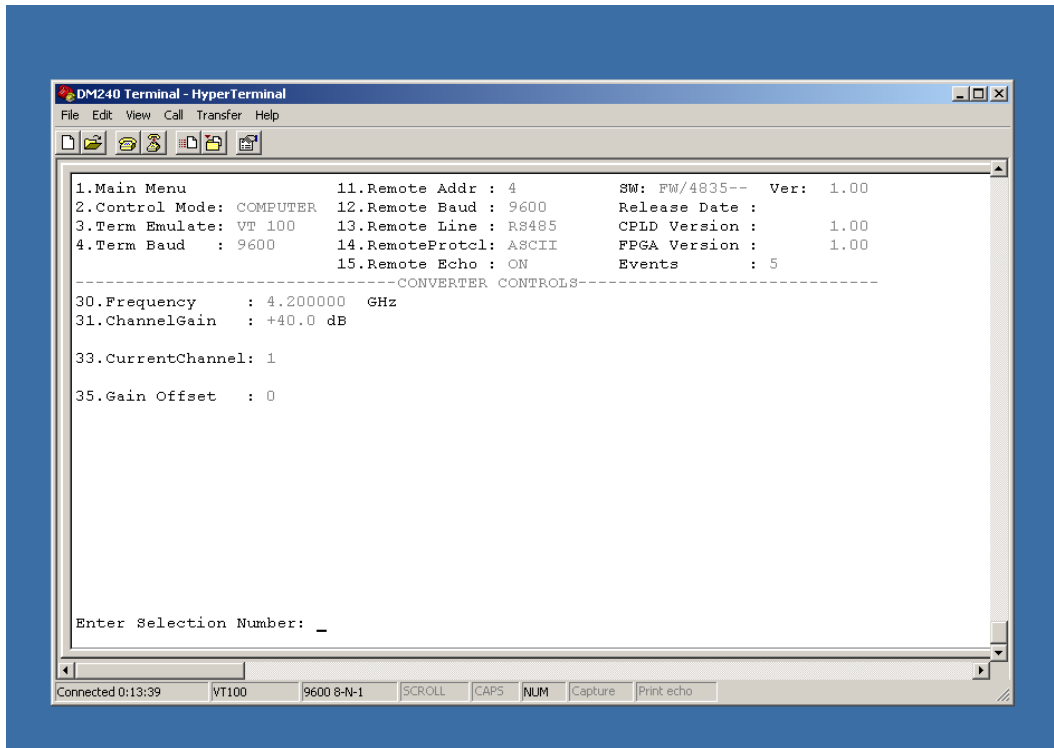

4.6.3 Terminal Switch Controls Menu

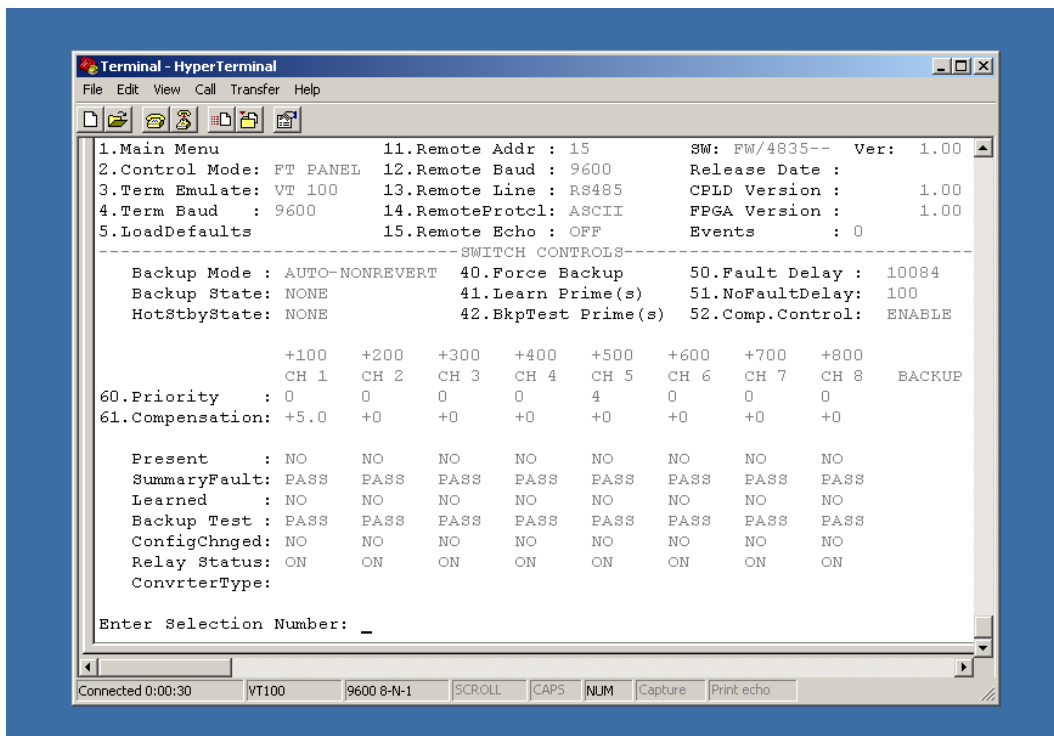

4.6.4 Terminal Alarm Status & Masks Menu

```

DM240 Terminal - HyperTerminal
File Edit View Call Transfer Help
-----
1.Main Menu          11.Remote Addr : 4      SW: FW/4835-- Ver: 1.00
2.Control Mode: COMPUTER 12.Remote Baud : 9600   Release Date :
3.Term Emulate: VT 100  13.Remote Line : RS485  CPLD Version : 1.00
4.Term Baud : 9600      14.RemoteProtcl: ASCII FPGA Version : 1.00
                          15.Remote Echo : ON    Events : 5
-----ALARM STATUS & MASKS-----
MAJ ALRMS  CURR LTCH MASK MINOR ALRMS CURR LTCH MASK  COM ALRMS  CURR LTCH MASK
30.LO Flt: PASS PASS NO  50.CPLDTst: PASS PASS NO
51.FPGATst: PASS PASS NO
52.EEPROM : PASS PASS NO
53.Ref Act: FAIL FAIL NO
54.Vcc1Flt: PASS PASS NO
55.+9V Flt: PASS PASS NO
56.+15VFlt: PASS PASS NO
57.-15VFlt: PASS PASS NO

37.Clear Latched Alarms

Enter Selection Number: _
-----
Connected 0:14:25  VT100  9600 8-N-1  SCROLL  CAPS  NUM  Capture  Print echo

```

4.6.5 Terminal Monitor Status Menu

```

DM240 Terminal - HyperTerminal
File Edit View Call Transfer Help
-----
1.Main Menu          11.Remote Addr : 4      SW: FW/4835-- Ver: 1.00
2.Control Mode: COMPUTER 12.Remote Baud : 9600   Release Date :
3.Term Emulate: VT 100  13.Remote Line : RS485  CPLD Version : 1.00
4.Term Baud : 9600      14.RemoteProtcl: ASCII FPGA Version : 1.00
                          15.Remote Echo : ON    Events : 5
-----MONITOR STATUS-----
Reference Status: INTERNAL  Converter Type : DN CONVERTER
RF Detector Vol : 0         Converter Band : CBAND
IF Detector Vol : 0         Down Band Type : CUSTOM
DAC AttenVoltage: 6.4      Frequency Type : 70MHZ
Vcc1 Voltage : 4.9         Synthesizer Type: MFS-459
+9V Voltage : 8.9         UserMinFrequency: 3.620000 GHz
+15V Voltage : 14.9       UserMaxFrequency: 4.200000 GHz
-15V Voltage : -14.9      Converter ID : 255
                          Converter Config: STAND ALONE

Enter Selection Number:
-----
Connected 0:14:43  VT100  9600 8-N-1  SCROLL  CAPS  NUM  Capture  Print echo

```

4.6.6 Terminal Test Controls Menu

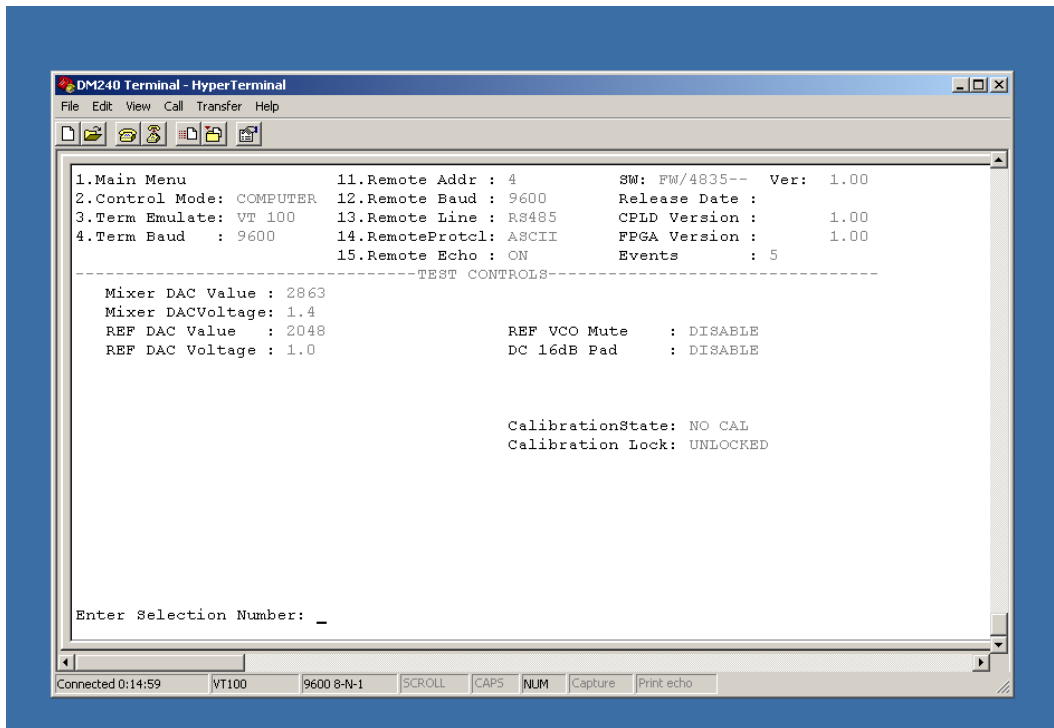

4.6.7 SNMP Controls Menu

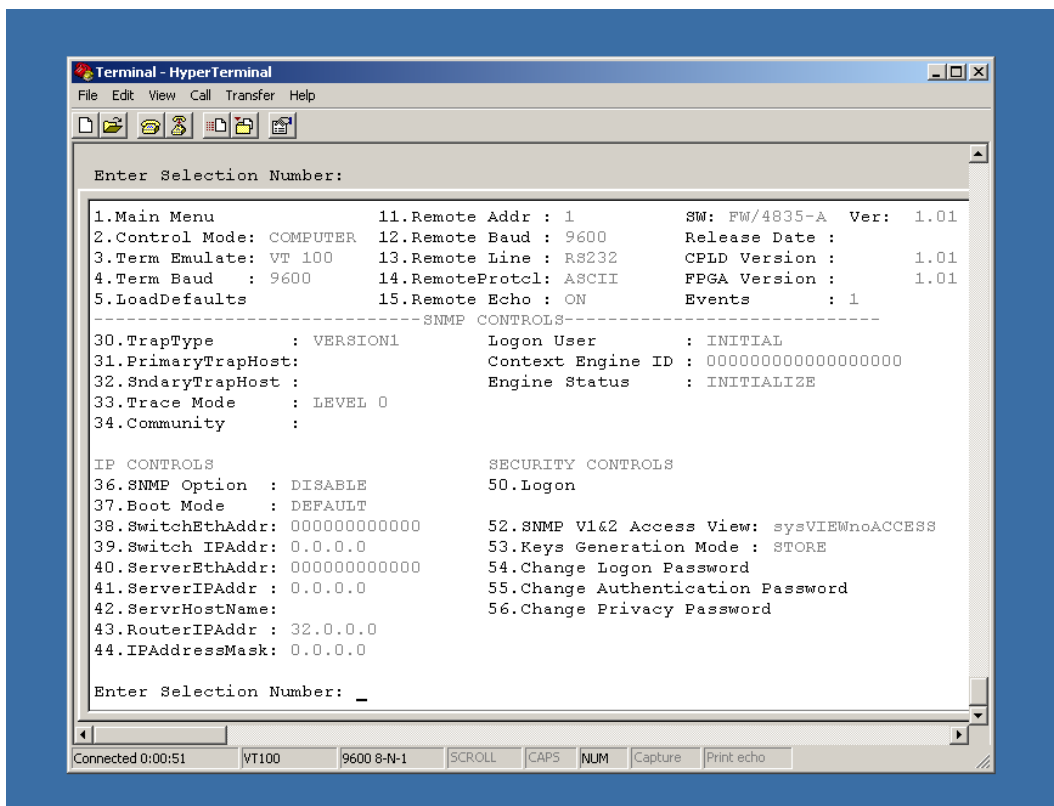

4.6.8 Terminal Event Buffer Menu

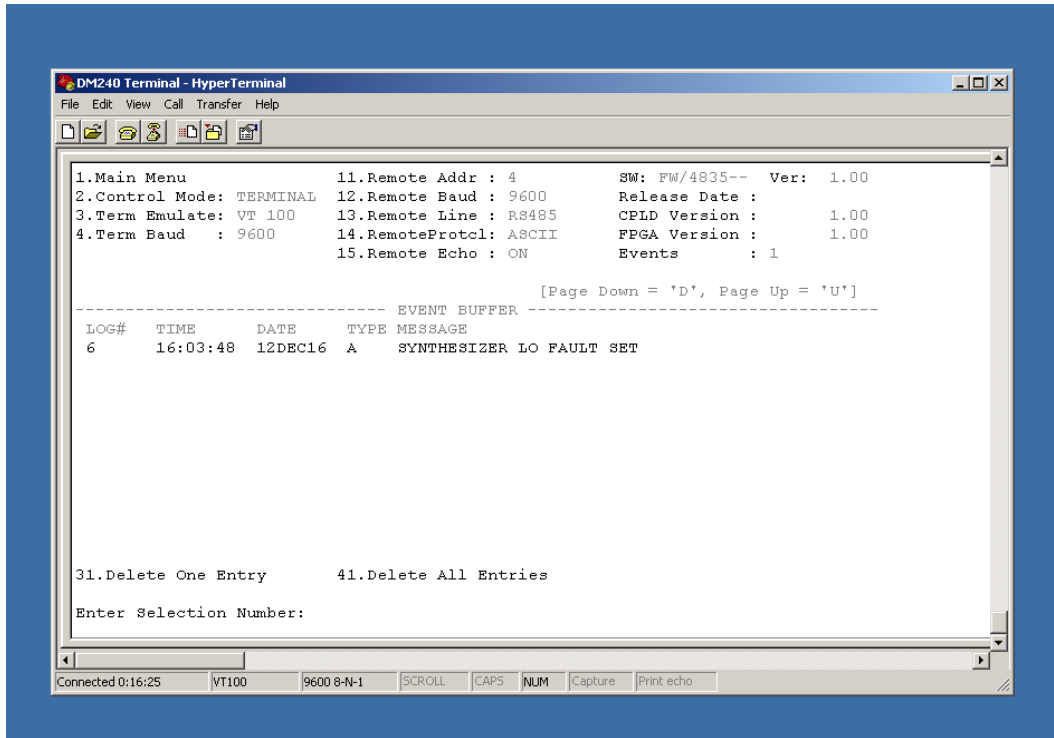

4.7 Ethernet Port User Interface

The Ethernet Port allows for complete control and monitoring of all Upconverter parameters and functions via a 10BaseT or 100BaseT Ethernet connection.

4.7.1 Ethernet Port Configuration

4.7.1.1 Connecting the Terminal

1. Connect a computer serial port (or dumb terminal port) to the SFC Upconverter Terminal Connector (J6) on the rear of the unit.
2. Verify that the emulation software is set to the following:

```

VT100
9600 baud
8 data bits
no parity
1 stop bit

```

Modify the Upconverter selection, if necessary, to match the settings (Front Panel Menu: *System>Terminal*>).

4.7.1.2 SNMP Option

1. From the Main Menu, select '6' for SNMP Control. Verify that Selection 36, SNMP Option is enabled. The SFC Upconverter SNMP Option is enabled at the factory if purchased by the user. Please contact the Comtech EF Data Customer Service Department if the SNMP feature is not available.

4.7.2 Network Configuration

4.7.2.1 Terminal Screens

1. The SNMP main setup screen is Menu 6. on the Terminal Main Menu screen.
2. The SNMP Configuration can be monitored and controlled via a full screen presentation of current settings and status. The <Esc> Key redraws the entire screen and aborts input any time. The Spacebar refreshes the status area and is used to scroll through selection when in user input mode.
3. To modify an item, the user simply presses its terminal selection followed by <ENTER>. The modem responds by presenting the options available and requesting input. If the input is multiple choices, the user is prompted to use the Spacebar to scroll to the desired selection and then press <ENTER>. An input can be aborted at any time by pressing <Esc>. Invalid input keys cause an error message to be displayed on the terminal. Some input or display status only appears when the user has the right access levels.

4.7.2.2 Logging on and Passwords

There are several available logon users each setup with a default password. The user must be logged on in order to view or change some settings. There are 3 levels of access rights in the SFC Upconverter. These are:

Initial Access: The default when no user is logged on.

Viewer Access: Allows its user to modify its own logon and authentication passwords.

Operator Access: All other SNMP and security selections can only be accessed.

Listed in the table below are the available user names and corresponding default passwords:

Security User	Logon Password	Authentication Password	Privacy Password
Initial			
Viewer	Viewer	Viewer	
Oper-md5	Oper	Oper	Oper
Viewer-sha	Viewer	Viewer	
Oper-sha	Oper	Oper	Oper

Note: All entries are case sensitive

4.7.2.3 Exiting SNMP Configuration

1. Select the Main Menu by pressing '1' followed by <ENTER>, to go back to the top-level Menu screen.

4.7.2.4 Logging On

1. The user must be logged on to have access to SNMP Features. To log on the SNMP configuration, press '50' followed by <ENTER> to open the Logon Dialog Box.

```

+-----+ | Logon | -----+
|                                             |
|           1.User ID :                      |
|           2.Password :                    |
|           3.OK           4.CANCEL          |
|                                             |
+-----+

```

2. In the User ID Text Box, enter "Oper-md5" (case sensitive).
3. In the Password Text Box, enter "Oper" (case sensitive).
4. Select OK

4.7.2.5 Changing the Logon Password

To change the password, logged on so that the "SNMP/Security" selection appears. Press '54' followed by <ENTER> to open the Change Logon Password dialog.

```

+-----+ | Change Password | -----+
|                                             |
|           1.Old Password:                 |
|           2.New Password:                 |
|           3.Re-enter New Password:       |
|           4.OK           5.CANCEL        |
|                                             |
+-----+

```

1. In the Old Password Text Box, enter "Oper" (case sensitive).
2. In the New Password Text Box, enter the new password (case sensitive, only *'s appear for security).
3. Re-enter the new password to verify the desired setting.
4. Select OK

4.7.2.6 Logging Off

1. To log off the SNMP Configuration, press '51' followed by <ENTER>. The following confirmation message will be displayed to avoid inadvertent exits:

You will be logged off. Are you sure? (Y/N):

4.7.2.7 Changing Your Authentication Password

1. Select 55. followed by <ENTER> to open the Change Password Dialog.

```

+-----| Change Password |-----+
|                                     |
|          1.Old Password:            |
|          2.New Password:           |
|          3.Re-enter New Password:  |
|          4.OK      5.CANCEL         |
|                                     |
+-----+

```

2. In the Old Password Text Box, enter “Oper” (case sensitive).
3. In the New Password Text Box, enter the new password (case sensitive, only *’s appear for security).
4. Re-enter the new password to verify desired setting.
5. Select OK

4.7.2.8 Changing Your Privacy Password

To change your privacy password, select 56 followed by <ENTER> to open the Change Password dialog.

```

+-----| Change Password |-----+
|                                     |
|          1.Old Password:            |
|          2.New Password:           |
|          3.Re-enter New Password:  |
|          4.OK      5.CANCEL         |
|                                     |
+-----+

```

1. In the Old Password Text Box, enter “Oper” (case sensitive).
2. In the New Password Text Box, enter the new password (case sensitive, only *’s appear for security).
3. Re-enter the new password to verify desired setting.
4. Select OK

4.7.2.9 Converter Ethernet Address

1. The Modem SFC6400A/SFC1450A High-Speed Microwave Modem Ethernet Address is configured at the factory. It is a unique Comtech EF Data equipment identifier.

Example: 0010650903EB

Note: Do not modify the Ethernet Address. Major problems may result if changed.

4.7.2.10 Converter IP Address

1. Select '39', Converter IP Address:. Enter the SFC Upconverter Internet Address in dot notation and press <ENTER>. Please consult your network administrator for valid addresses.

Example - 192.168.0.35

2. The IP Address that is selected will be used for the Ethernet Test that follows.

4.7.2.11 Server Ethernet Address

This section refers to the boot host.

1. Select 40.ServerEthAddr:. Enter the Server 12 Digit Ethernet Address and press <ENTER>. Zero out this address if not known at this time. The system will resolve it dynamically at run time.

Example: 0FD0640203ED or 000000000000

4.7.2.12 Server IP Address

This section refers to the Host that will be used to optionally boot the Upconverter on power-up. The host should be acceptable to the transport layer. In other words, the transport layer needs to be able to open a connection to the entity specified by the server IP Address field.

1. Select 41.ServerIPAddr :. Enter the Server Internet Address in dot notation and press <ENTER>. Please consult your network administrator for valid addresses.

Example: 192.168.0.50

2. The IP Address that is selected will be used for the Ethernet Test that follows.

4.7.2.13 Router IP Address

Select 42.RouterIPAddr :. Enter the router Internet Address in dot notation and press <ENTER>. Please consult your network administrator for valid addresses.

Example: 192.168.0.254

4.7.2.14 IP Address Mask

In the mask (more clearly seen in the binary format), binary 1s indicate the position of the network and subnet portion of the IP Address while binary 0s identify bits that represent the individual interfaces. To recognize a subnet, each system in the subnet must have the same subnet mask. Please consult your network administrator for a valid address class mask.

1. Select 43.IPAddressMask:. Enter the IP Address mask in dot notation and press <ENTER>.

Example: 255.255.0.0

4.7.2.15 Boot Mode (Optional)

1. Select 37.Boot Mode : from the Controls Menu and press <ENTER>. Scroll through the various selections to 'NVBOOT' and press <ENTER>. The above settings will be enabled the next time the system is rebooted. If a bootp server is available, the Upconverter can be remotely configured by selecting bootp mode. This option is currently not available.

4.7.2.16 Community

Each managed station controls its own local MIB and must be able to control the use of that MIB by a number of management stations. This relates to security concerns. A managed MIB such as the Upconverter needs to protect itself from unwanted and unauthorized access. SNMP, as defined in RFC 1157, provides only a limited capability for such security, namely the concept of a community. An SNMP Community is the relationship between an SNMP Agent and Management Stations.

1. To set the community string on the SFC Upconverter, select 34.Community:. Enter the desired community name and press <ENTER>.

Example: "public"

4.7.2.17 Trap Type and Trap Hosts

Traps enable the converter to notify the management station of significant events such as alarms. Version1 and version2 Traps are supported at this time. These are Operator selectable using Terminal Command Number 30. The messages are sent to specific pre-defined hosts. The Primary and Secondary Trap Hosts IP Addresses are setup using Terminal Commands 31 and 32. Each host should be acceptable to the transport layer. In other words, the transport layer needs to be able to open a connection to the entities specified by the trap host fields.

4.7.2.18 Trace Mode

1. For debugging purposes, a trace mode is specified by the Operator users for various diagnostic levels.

4.7.2.19 SNMP V1 & 2 Access View

The default access rights for Version 1 and 2 SNMP users are minimal. They are limited to a system view, and a description of the Upconverter System and Contact Information. For additional information, go to View-Based Access Control Section. To accommodate older systems, an Operator user may modify these access rights to allow full or partial read/write access. SNMP Version 1 and 2 does not use any security measures, therefore users should be very careful when changing access rights.

4.7.2.20 Key Generation Mode

The password localization algorithm is intensive enough that the Motorola 68332 Embedded Processor cannot handle the process in a timely manner. This selection allows the Operator user to optionally store localized keys in non-volatile memory. These keys correspond to a set of passwords and Modem IP Address. If either changes, the SNMP agent automatically recalculates the new keys and stores them in non-volatile memory (only if the Key Generation Mode is set to 'STORE').

4.7.2.21 Context Engine ID

“contextEngineID” is the unique identifier of the Upconverter SNMP Engine that provides services for sending and receiving messages, authenticating and encrypting messages, and controlling access to managed objects.

1. The Context Engine ID, 80000A1F01AC1264B0, is formatted as follows:
 - a. The first 4 bytes are the Radyne Private Enterprise Number (2591).
 - b. The very first bit is set to 1, for example: 80000A1F (H).
 - c. The fifth byte indicates how the 6th and remaining bytes are formatted. A ‘1’ means it’s an IPv4 Address.
 - d. The last 4 bytes are the IP Address 172.18.100.176 (AC1264B0).

4.6.2.22 View-Based Access Control

SNMPv3 defines a method of access control known as the View-based Access Control Model (VACM). It is defined as a means to restrict access to particular subsets of variables based on the identity of the manager and the security level used in the request.

A view is a group of MIB variables on the agent. The agent defines a view for each user based on the user identity (securityName) and security level. Following are the major views:

System view: Access to system description

MIB-II view: Access to the standard MIB-II information

Device view: Access to the device private information

World view: Access to every managed object in the MIB

Following are the available access groups:

Group	Context/Community	Security Level	Read Access	Write Access
NULL	mib2	NoAuth/noPriv	System view	NONE
Viewer	mib2	Auth/noPriv	MIB-II view	NONE
Viewer	Dev	Auth/Priv	Device view	NONE
Oper	mib2	Auth/noPriv	MIB-II view	MIB-II view
Oper	Dev	Auth/Priv	Device view	Device view

The NULL Security Name is for backward compatibility with SNMP Version 1 and 2 management stations (security names are not defined for earlier protocols). In this case, the contextName in each view may refer to either a contextName or a communityName. The securityLevel would then be noAuth/noPriv.

4.7.3 Connecting the Ethernet Cable and Testing the Link

1. Connect the computer to the Upconverter Ethernet port (J9) using the RJ-45 to RJ-45 10BaseT Cables via a hub as shown in Figure 4-3.

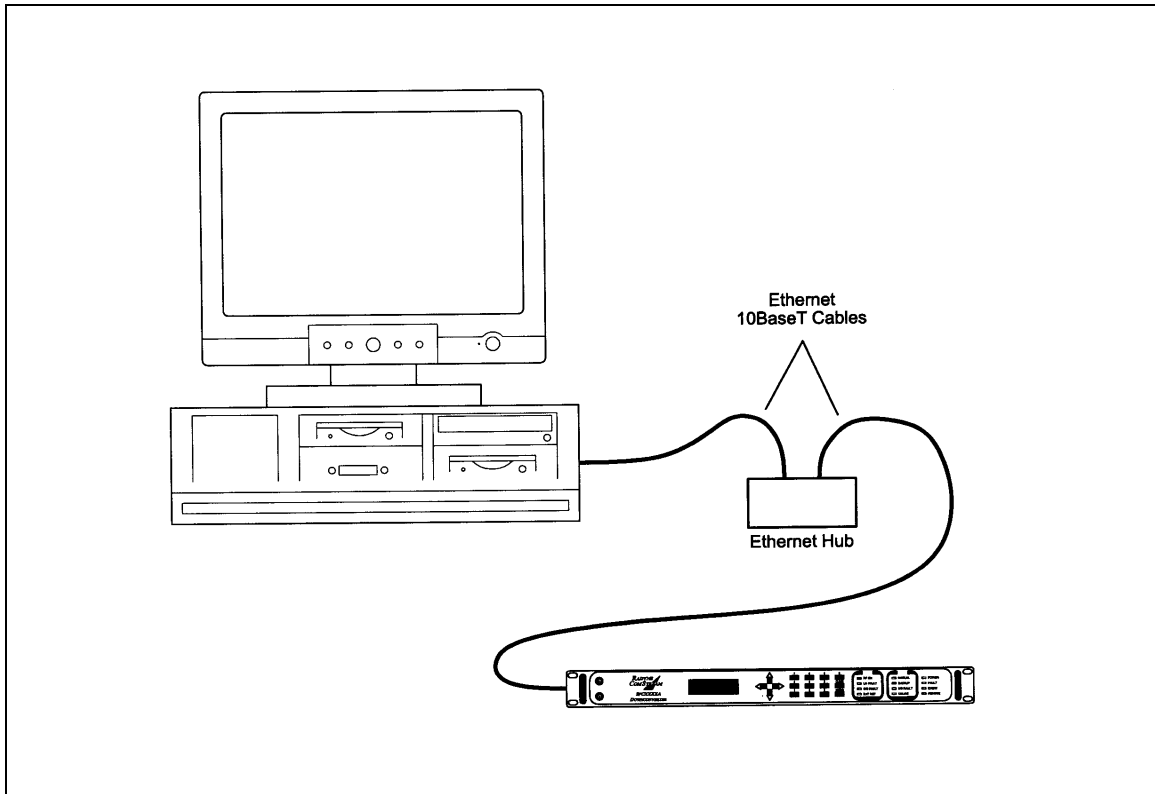

Figure 4-3. Ethernet Connection

4.7.3.1 Ping Program

1. PING is an application that uses the ICMP protocol to report if a host is responding. To check whether the SFC Upconverter is reachable, use the PING program installed on your computer along with the modem IP Address set in Section 3.2.3.

Example: ping 192.168.0.35

2. If everything is functioning correctly, replies from the modem will appear on the computer screen along with the time it took to respond. If unsuccessful, verify the following:
 - a. The cables are secured.
 - b. The Link Light is illuminated.
 - c. The IP Address that is used matches the Modem's IP Address.
 - d. The Server and Modem are on the same subnet.

4.7.3.2 SNMP Test

1. Once it is determined that the SFC Upconverter is reachable, compile the custom Management Information Base (MIB) for use by the Network Management Station (NMS). The MIB uses a hierarchical naming scheme. Each managed object in the Upconverter is identified by an Object Identifier (OID), a sequence of non-negative integers that uniquely describes the path taken through the hierarchical structure.
2. Using the Upconverter IP Address, perform a Walk of the MIB to retrieve all the MIB objects managed in the Upconverter.

4.7.4 Management Information Base Structure

This section defines the terminology and hierarchy associated with management information base structure at Comtech EF Data.

4.7.4.1 Simple Network Management Protocol (SNMP)

Simple Network Management Protocol (SNMP), as its name suggests, is a relatively simple protocol by which management information for a network device may be inspected and/or altered by remote administrators.

4.7.4.2 The Management Information Base (MIB)

Management objects are defined in the Management Information Base (MIB), which uses a hierarchical naming scheme. In this scheme, an Object Identifier (OID) identifies each object. The OID is a sequence of non-negative integers that uniquely describes the path taken through the hierarchical structure.

MIB objects may then be specified either from the Root (which has no designator), or alternatively from anywhere within the hierarchical structure.

For example: 1.3.6.1.4.1.2591.4 is equivalent to {iso(1). org(3). dod(6). internet(1). private(4). enterprises(1). Radyne(2591). RCS10L(4)} (See Figure 4-4).

In general, we are mainly concerned with just two groups that reside in the *internet* subtree, namely the *mgmt*, and *private* groups. For completeness however, the four major groups are discussed below:

Directory {internet 1} 1.3.6.1.1

This area was reserved to describe how the OSI directory structure may be used in the Internet. To date this has not been implemented and therefore is of little interest to us.

Mgmt {internet 2} 1.3.6.1.2

This area was reserved to describe objects in the standard MIB. As RFCs defining new groups are ratified, the Internet Assigned Numbers Authority (IANA) assigns new group IDs.

Experimental {internet 3} 1.3.6.1.3

This subtree provides an area where experimentation is carried out. Only those organizations directly involved in the experiment have any interest in this subtree.

Private {internet 4} 1.3.6.1.4

This is possibly the most important area of the MIB, since it is within this subtree that vendors place objects specific to their particular devices. Beneath the private branch, there is a subtree called enterprises, beneath which each vendor may define its own structure. Vendors are assigned Private Enterprise Numbers (PENs) that uniquely identify them. They may then place all objects specific to their devices in this tree, provided of course that the object conforms to the format defined by SMI. Comtech EF Data's Private Enterprise Number is 2591. Other products are added to Comtech EF Data's subtree as they become remotely manageable through SNMP.

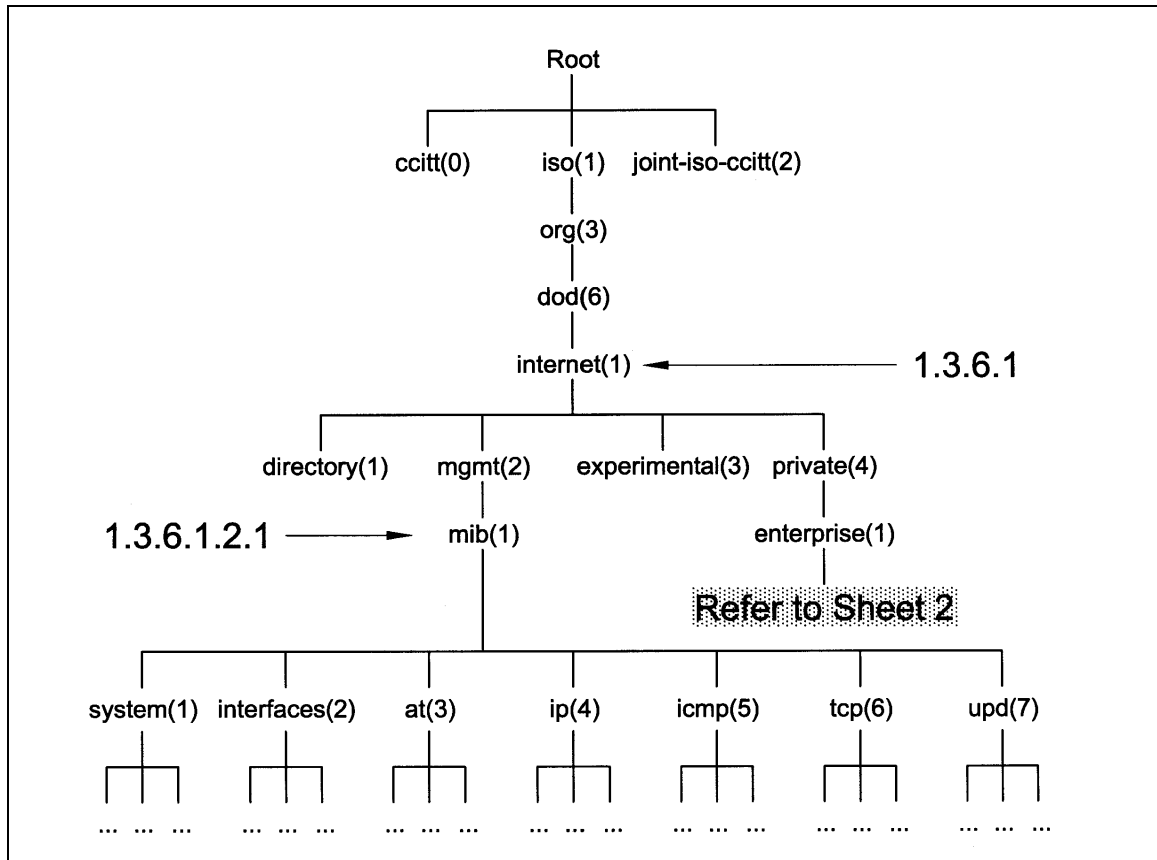

Figure 4-4. Object Identifiers in the Management Information Base (Sheet 1 of 2)

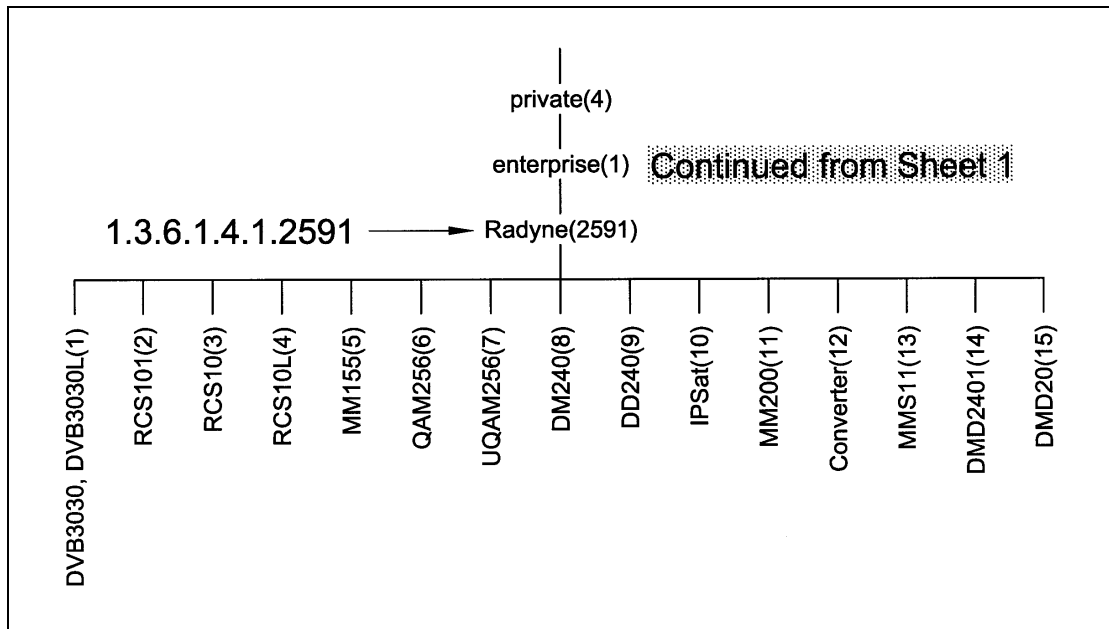

Figure 4-5. Object Identifiers in the Management Information Base (Sheet 2 of 2)

Refer to Appendix C for MIB listing.

Chapter 5. Rear Panel Interfaces

5.1 SFC Upconverter Connections

All SFC Upconverter connections are made to labeled connectors. Any connection to an SFC Upconverter must be made with the appropriate mating connector. Refer to Figure 5-1 for the various connector locations.

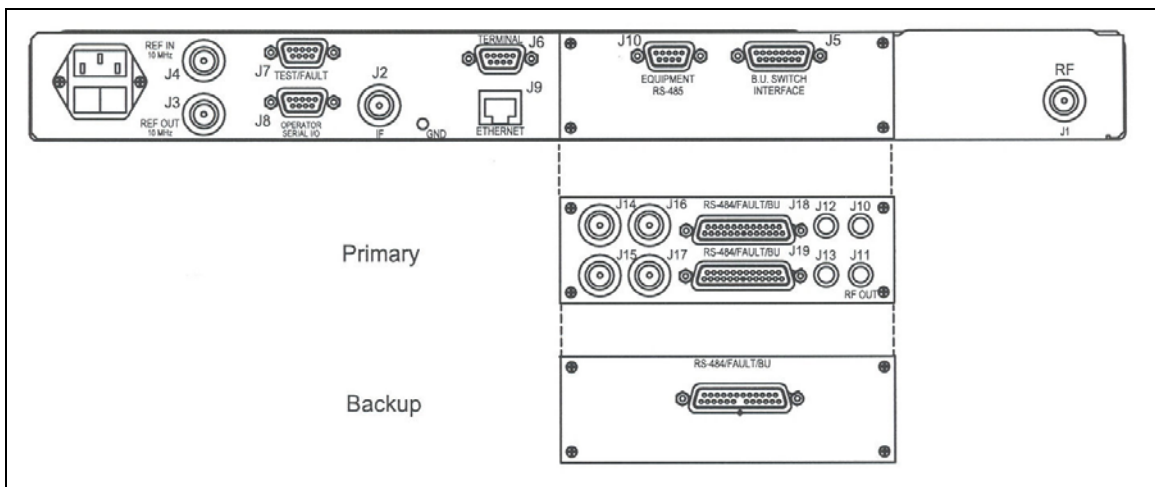

Figure 5-1. SFC Upconverter Back Panel

5.2 Power

Located on the left side of the SFC Upconverter Rear Panel is the AC Power Input Connector. This connector is an IEC/EN60320/C13 Power Entry Module. The unit is powered from a 100 – 240 VAC, 50 – 60 Hz source. Maximum unit power consumption is 50 W. The switch turns power on and off to the unit. A chassis ground connection can be made at the #10 size stud located between the IF (J2) and Ethernet (J9) connectors.

The Power Cord/connector for the SFC Upconverter is a supplied item.

5.3 10 MHz Ref In (J4)

The Reference Input is a 50 ohm BNC-F connector (J4) allows the operator to synchronize the synthesizer of the converter to an external 10 MHz reference. When an external reference is properly applied to the reference input, the external reference LED will illuminate on the front panel.

5.4 10 MHz Ref Out (J3)

The 10 MHz Reference Out (J3) is a 50 ohm BNC-F Connector that provides a 10 MHz square wave, 50 ohm AC coupled reference output signal at 0 dBm. In normal operation (no external reference) this output is synchronous with the internal high stability 10 MHz reference.

5.5 Test/Fault (J7)

The Test/Fault connector (J7) is a status port that allows monitoring of several system status indications at the back panel. These items are described in Table 5-1.

Table 5-1. J7 – Test/Fault Interface – D-Sub 9-Pin Female Connector			
Pin No.	Signal	I/O	Description
1	N.C.	N.A.	No Connect
2	IF_LO_FAULT	O	1 = LO Fault Condition
3	GND	N.A.	Ground
4	IF_SIG_DET	O	Detected Power Level of IF Signal 0 to 5 VDC
5	N.C.	N.A.	No Connect
6	RLY_NO	N.A.	Form-C relay normally open contact, summary fault
7	RLY_NC	N.A.	Form-C relay normally closed contact, summary fault
8	RLY_C	N.A.	Form-C relay common contact, summary fault
9	RF_SIG_DET	O	Detected Power Level of RF Signal (Upconverter only, 0 - 5 VDC)

5.6 Operator Serial I/O (J8)

The Operator Serial I/O Port (J8) is a D Sub 9-Pin Female Connector. This port provides a serial interface that can be configured as either an RS-232 or RS-485 interface and allows the user to remotely control all of the features outlined in the Serial Protocol (See Section 4.2, Remote Port User Interfaces). The serial port comes configured as an RS-232 Serial Port for DCE unless otherwise indicated. The pinout for this interface is listed in Table 5-2. Note that the function of pin 1 and pin 9 depends on whether the protocol is set to RS-232 or RS-485 (Front Panel LCD Menu: SYSTEM < REMOTE PORT < REMOTE LINE).

Pin No.	Signal	I/O	Description
1	RX_485 – A RX_232	I	Inverted RS-485 Receive RS-232 receive
2	TX_485-B	O	Non-Inverted RS-485 transmit
3	RX_485-B	I	Non-Inverted RS-485 receive
4	DTR	N.A.	Connected internally to Pin 6-DSR
5	GND	N.A.	Ground
6	DSR	N.A.	Connected internally to Pin 4-DTR
7	RTS	N.A.	Connected internally to Pin 8-CTS
8	CTS	N.A.	Connected internally to Pin 7-RTS
9	TX_485 – A TX_232	O	Inverted RS-485 Transmit RS-232 Transmit

If the RS-232 option is chosen, an adapter must be used between J8 and the serial cable to the DTE. One end of the adapter will be a DB9-M connector, which plugs into J8 on the Upconverter back panel. The other end will be a DB9-F connector, which plugs into the PC serial port or dumb terminal. The pinout is given in Figure 5-3.

Pin No.	DB9 Male to Upconverter J8	Pin No.	DB9 Female to DTE
	1		3
	5		5
	9		2
	2,3,4,6,7,8		N.A.

5.7 IF In (J2)

The IF In Connector (J2) is a 75Ω BNC-F Connector. Input is specified at 70 Mhz or 140 Mhz.

5.8 Terminal (J6)

The Terminal Port allows for complete control and monitoring of all Upconverter parameters and functions via an RS-232 Serial Interface. The interface comes configured as a DCE device. The pinout is given in Table 5-4.

Table 5-4. J6 – Terminal Port – D-Sub 9-Pin Female Connector			
Pin No.	Signal	I/O	Description
2	TX_232	O	RS-232 transmit
3	RX_232	I	RS-232 receive
5	GND	N.A.	Ground
1, 4, 6, 7, 8, 9	N.A.	N.A.	No Connect

5.9 Ethernet (J9)

The Ethernet connector can be used for monitor & control functions of the Upconverter. The physical interface is a standard RJ-45 connector.

5.10 Equipment RS-485 (J10), Standard Backward Compatible Interface

The Equipment Multi-Drop, Full-Duplex, Bi-directional RS-485 Interface (J10) allows communication between converters. Because the RS-485 Interface uses a master/slave (talker/listener) configuration, the converter that is designated as the backup will automatically be established as the master. Under normal RS-485 protocol, the master will poll a specific slave by address and only then will the slave unit respond. The swapping of Transmit Data and Receive Data is accomplished in the inter-converter cables, as the hardware interface is identical for all converters. Refer to Table 5-5 for the connector pinout.

Table 5-5. J10 – Equipment RS-485 Interface D-Sub 9-Pin Female Connector			
Pin No.	Signal	I/O	Description
1	GND	N.A.	Ground
2	I2C_SCL	O	I2C Clock
3	N.C.	N.A.	No Connect
4	TX_485-B	O	Inverted RS-485 transmit
5	TX_485-A	O	Non-Inverted RS-485 transmit
6	I2C_SDA	I/O	I2C Data
7	N.C.	N.A.	No Connect
8	RX_485-B	I	Inverted RS-485 receive
9	RX_485-A	I	Non-Inverted RS-485 receive

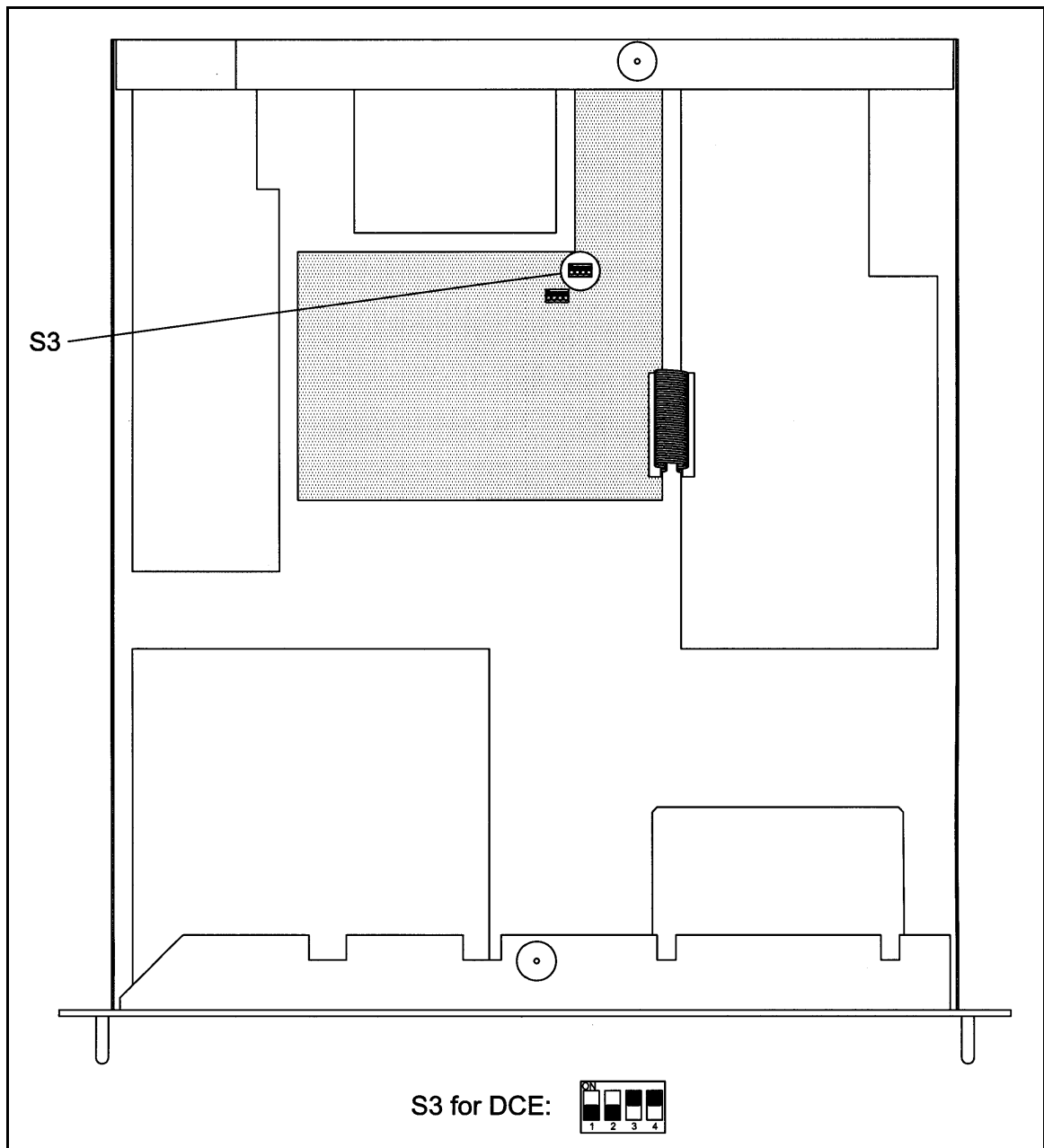

Figure 5-2. DIP Switch Setting for DCE

5.11 B/U Switch Interface (J5), Standard Backward Compatible Interface

The Backup Switch Interface (J5) is a D Sub 15 Pin Female Connector that connects each converter with the RCU101 or RCU108 Backup Switch Unit. This cable is not daisy-chained between converters, but serves as a direct link for each converter in the configuration, whether they are the individual online converters or the backup unit. This interface finds use in both the 1:1 and 1:N configuration type switches. The pinout of the switch is listed in Table 5-6.

Table 5-6. J5 – Backup Switch Interface – D-Sub 15-Pin Female Connector			
Pin No.	Signal	I/O	Description
1	RLY_NO	N.A.	Form-C relay normally open contact, summary fault
5	RLY_NC	N.A.	Form-C relay normally closed contact, summary fault
9	RLY_C	N.A.	Form-C relay common contact, summary fault
13	GND	N.A.	Ground
2	+15_OR	N.A.	Diode Or'd +15 VDC from converter
6	FAULT_INT1	Input	RCU101 ONLINE status indicator
10	FAULT_INT2	Input	RCU101 Manual Mode indicator A
14	FAULT_INT3	Input	RCU101 Manual Mode indicator B
3	FAULT_INT3	N.A.	Spare
7	ID_INT0	Input	Converter Switch position ID bits.
11	ID_INT1	Input	
15	ID_INT2	Input	
4	ID_INT3	Input	
8	INT	N.A.	Spare
12	RMT	Output	RCU101 Manual Remote Control

5.12 RF Out (J1)

The RF Out (J1) is the RF Output of the SFC Upconverter. It is an N-Type Female Connector for the SFC6400A, and an SMA Female Connector for the SFC1450A.

5.13 Monitor Ports

The SFC Upconverters have Monitor Ports located on the Front Panel (Figure 5-3) that allow the operator to monitor the IF Output and RF Input.

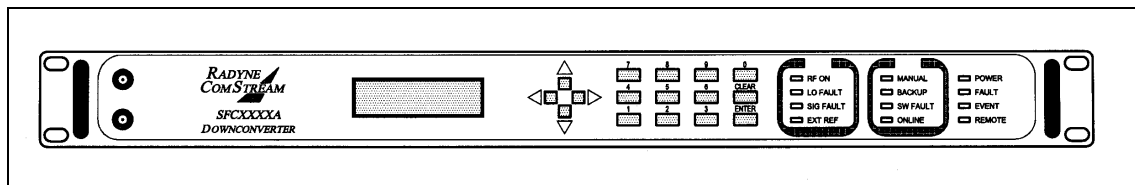

Figure 5-3. SFC Upconverter Front Panel with Monitor Ports

5.13.1 IF Monitor Port

The IF Monitor Port is an SMA-F Type Connector located on the front panel that allows monitoring of the Upconverter's IF Output. The power level of the monitored signal will be -15 dB nominal below the level present at J2.

5.13.2 RF Monitor Port

The RF Monitor port is an SMA-F Type Connector located on the front panel that allows monitoring of the Upconverter's RF Input. The power level of the monitored signal will be -15 dB nominal below the level present at J1.

5.14 Optional Chain Switching Module

5.14.1 (J10)

J10 is an SMA-F Type Connector. When connected to J1 in the chain switching configuration, it provides a direct path for the RF Input through the switch module for non-faulted conditions.

5.14.2 (J11)

J11 is an SMA-F Type Connector. It is the RF Output of the SFC Upconverter in the chain switching configuration.

5.14.3 (J12 and J13)

J12 and J13 are SMA-F Type Connectors that provides an RF signal path from the backup converter to each converter in the redundancy chain in a non-fault condition. During a fault condition, the faulted converter changes the flow from J10 to J11 to J13 to J11 and receives the RF from the backup converter via the J12 and J13 RF path.

5.14.4 (J14)

J14 is a BNC Female Connector. It is connected to the Converter IF Input (J2). In a non-faulted condition, the through path of the switch module is from J15 to J14.

5.14.5 (J15)

J15 is a BNC Female Connector. It is the IF input of the SFC Upconverter in the Chain Switching configuration.

5.14.6 (J16 and J17)

J16 and J17 are BNC Female Connectors that provide an IF signal path from the backup converter to each primary converter in the converter chain. In a faulted condition, the switch will change the IF flow from J15 to J14 to J15 to J17 redirecting the IF signal to the backup converter via the J16 and J17 signal paths.

5.14.7 (J18), Chain Switch Module

J18 is a D Sub 25 Pin Female Connector that is a combination of the RS-485 and B/U Switch Interfaces. This connector connects each converter in a daisy chain configuration with the backup master converter.

Table 5-7. J18 – D-Sub 25-Pin Female Connector			
Pin No.	Signal	I/O	Description
1	+15 V_SW	---	+15 VDC Power Bus
2	+15 V_SW	---	+15 VDC Power Bus
3	TX_485-A_SW	Out	Inverted RS-485 Transmit
4	RX_485-A_SW	In	Inverted RS-485 Receive
5	I2C_SDA_SW	I/O	I2C Data
6	ID_OUT_SW0	Out	Converter Position ID Bit 0
7	ID_OUT_SW2	Out	Converter Position ID Bit 2
8	FAULT_SW1	In	Switch Fault Indicator – Prime 1
9	FAULT_SW3	In	Switch Fault Indicator – Prime 3
10	FAULT_SW5	In	Switch Fault Indicator – Prime 5
11	FAULT_SW7	In	Switch Fault Indicator – Prime 7
12	GND	---	Ground
13	GND	---	Ground
14	+15 V_SW	---	+15 VDC Power Bus
15	N/C	---	No Connection
16	TX_485-B_SW	Out	RS-485 Transmit
17	RX_485-B_SW	In	RS-485 Receive
18	I2C_SCL_SW	Out	I2C Clock
19	ID_OUT_SW1	Out	Converter Position ID Bit 1
20	ID_OUT_SW3	Out	Converter Position ID Bit 3
21	FAULT_SW2	In	Switch Fault Indicator – Prime 2
22	FAULT_SW4	In	Switch Fault Indicator – Prime 4
23	FAULT_SW6	In	Switch Fault Indicator – Prime 6
24	FAULT_SW8	In	Switch Fault Indicator – Prime 8
25	GND	---	Ground

5.14.8 (J19), Chain Switch Module, Primary Only

J19 is a D Sub 25 Pin Female Connector that is a combination of the RS-485 and B/U Switch Interfaces. This connector connects each converter in a daisy chain configuration with the backup master converter.

Table 5-7. J19 – D-Sub 25-Pin Female Connector			
Pin No.	Signal	I/O	Description
1	+15 V_SW	---	+15 VDC Power Bus
2	+15 V_SW	---	+15 VDC Power Bus
3	TX_485-A_SW	Out	Inverted RS-485 Transmit
4	RX_485-A_SW	In	Inverted RS-485 Receive
5	I2C_SDA_SW	I/O	I2C Data
6	ID_IN_SW0	In	Converter Position ID Bit 0
7	ID_IN_SW2	In	Converter Position ID Bit 2
8	FAULT_SW1	Out	Switch Fault Indicator – Prime 1
9	FAULT_SW3	Out	Switch Fault Indicator – Prime 3
10	FAULT_SW5	Out	Switch Fault Indicator – Prime 5
11	FAULT_SW7	Out	Switch Fault Indicator – Prime 7
12	GND	---	Ground
13	GND	---	Ground
14	+15 V_SW	---	+15 VDC Power Bus
15	N/C	---	No Connection
16	TX_485-B_SW	Out	RS-485 Transmit
17	RX_485-B_SW	In	RS-485 Receive
18	I2C_SCL_SW	Out	I2C Clock
19	ID_IN_SW1	Out	Converter Position ID Bit 1
20	ID_IN_SW3	Out	Converter Position ID Bit 3
21	FAULT_SW2	Out	Switch Fault Indicator – Prime 2
22	FAULT_SW4	Out	Switch Fault Indicator – Prime 4
23	FAULT_SW6	Out	Switch Fault Indicator – Prime 6
24	FAULT_SW8	Out	Switch Fault Indicator – Prime 8
25	GND	---	Ground

Chapter 6. Maintenance and Troubleshooting

6.1 Periodic Maintenance

Radyne SFC Upconverters are designed to provide many thousands of hours of continuous operation. Normal aging and drifting of electronic components can cause the accuracy of the converter to change over time. As with any converter, these changes will affect the frequency accuracy and frequency conversion amplitude accuracy over time.

6.2 Failure Analysis

Faults in the converter are limited in scope to either a LO Fault or a Signal Fault. Other faults, such as a failure of the micro controller, may or may not provide an indication.

Chapter 7. Technical Specifications

7.1 Introduction

This section defines the technical performance parameters and specifications for the SFC Synthesized Frequency Upconverters

7.2 Input Characteristics

Frequency:	70 MHz \pm 18 MHz standard; 140 MHz \pm 36 MHz optional
Impedance:	75 Ω
Return Loss:	>23 dB
P1 dBm Input:	-15 dBm (Input Attenuator @ 0 dB)
Pin Nominal:	-25 dBm (Input Attenuator @ 0 dB)
Connector:	BNC Type F

7.3 Output Characteristics

Frequency:	SFC6400A 5.845 - 6.425 GHz Standard 5.845 - 6.650 GHz Extended SFC1450A 14.0 - 14.5 GHz Standard 13.75 - 14.5 GHz Extended
Impedance:	50 Ω
Return Loss:	>19 dB
P1 dBm Output:	SFC6406 +15 dBm minimum SFC1450 +10 dBm minimum
Output Attenuation:	0 - 20 dB Continuously, variable in 0.1 dB steps
Connector:	N, type-F

Note: Performance specifications guaranteed at nominal levels only.

7.4 Transfer Characteristics

Type:	Double conversion, no spectral inversion
Gain:	30 dB Maximum @ 0 dB total attenuation
Gain control:	50 dB in 0.1 dB increments (30 dB to -20 dB conversion gain)

Gain Ripple:	SFC6400 ± 0.25 dB/36 MHz typical, ± 0.50 dB maximum SFC1450 ± 0.50 dB/36 MHz typical, ± 0.75 dB maximum
Gain Slope:	± 0.05 dB/MHz
Gain stability:	± 0.25 dB/24 hr., ± 1.0 dB; 0 to 50°C
Spurious:	-80 dBm LO related spurious (in-band) at maximum gain -60 dBc signal related spurious (in-band) at minimum attenuation
Third Order Intercept:	SFC6400 +27 dBm -44 dBc IMD two tones with +5 dBm total output power SFC1450 +23 dBm -46 dBc IMD two tones with .0 dBm total output power
AM/PM Conversion:	0.1°/dB @ +5 dBm Output
Group Delay Linear:	0.025 nsec/MHz
Parabolic:	0.005 nsec/MHz ²
Ripple:	1 nsec p-p
Carrier Mute:	80 dBm minimum.

7.5 Frequency Synthesizer Characteristics

Resolution:	125 kHz Step Size
Accuracy:	$\pm 5 \times 10^{-9}$
Stability:	$\pm 5 \times 10^{-9}$ over temperature (0 to 50° C) $\pm 1 \times 10^{-9}$ /24 hours
Accuracy:	$\pm 5 \times 10^{-9}$

7.6 Single Side Band Phase Noise

<u>Offset</u>	<u>Standard SFC4200A</u>	<u>Standard SFC1275A</u>
10 Hz:	-50 dBc/Hz	-50 dBc/Hz
100 Hz:	-70 dBc/Hz	-60 dBc/Hz
1 kHz:	-80 dBc/Hz	-80 dBc/Hz
10 kHz:	-88 dBc/Hz	-84 dBc/Hz
100 kHz:	-95 dBc/Hz	-94 dBc/Hz
1 MHz:	-110 dBc/Hz	-110 dBc/Hz
External Reference:	10 MHz, 0 dBm, 50Ω (5 MHz Optional)	

7.7 Operator Interface

Front Panel:	Keypad control, and LED and LCD indicators
Remote Interfaces:	Terminal (RS-232), ASCII and RLLP (RS-232/RS-485) Serial Interfaces, and SNMP (Ethernet)
Rear Panel Connections:	RF output (N-type) IF input (75 Ohm BNC) Operator Serial Port (D sub 9-pin) 10 MHz REF in (50 Ohm BNC) 10 MHz REF Out (50 Ohm BNC) Fault/Test (D sub 9-pin) Switch Interface (D sub 15-pin) Equipment RS-485 Interface (D sub 9-pin), IEC/EN60320/C13 Power Entry Module/ Switch #10 Ground Lug
Front Panel Test Ports:	RF monitor -15 dB SMA-F, IF Monitor -15 dB SMA-F

7.7.1 Converter Settings

Monitored and/or controlled from the Front Panel or remotely, using the RS-232/RS-485 or Ethernet remote port:

- Frequency
- Channel Gain
- The Current Channel
- Gain Offset
- Event Buffer
- Faults Status and Mask
- Power Supply Voltages
- Frequency Reference Status and Offset Control
- Input Attenuation
- Remote Protocol
- Baud, Line, and Echo Modes
- Carrier Control and Status
- Converter Band and User Minimum/Maximum Frequencies
- Converter and Frequency Type
- Terminal Emulation and Baud Rate
- RF Detector
- IF Detector and DAC Attenuation Voltages

7.7.2 Switch Settings

Monitored and/or controlled from the Front Panel or remotely using the RS-232/RS-485 or Ethernet remote port (backup only):

Priority
 All Available Prime Summary Fault
 Fault Delay
 All Available Prime Learn Status
 Force Backup
 All Available Prime Backup Test Status
 Learn Control
 All Available Prime Configuration Change Status
 Backup Testing
 All Available Prime Relay Status
 Compensation Control
 All Available Prime Converter Types

7.7.3 LED Indicators

Standby
 LO Fault
 Signal Fault
 External Reference Online
 Backup
 Software Fault
 Manual (Backup Only)
 Power
 Fault
 Event
 Remote

7.8 Physical Characteristics

Size:	19.0" x 1.75" x 19.0" Deep (48.26 cm x 4.44 cm x 48.26 cm)
Weight:	12 lb. (5.44 kg)
Primary Power:	100 - 240 VAC, 50 - 60 Hz, 1.0 A
Power Consumption:	50 Watts

7.9 Environmental Characteristics

Temperature:	0 to 50°C
Humidity:	To 95% Non-Condensing
Altitude:	To 8,000 ft. (2438 m) AMSL
Shock & Vibration:	No loss of frame synchronization at the BER Test Set due to a standard hammer drop test on any outside surface of the converter. Likewise, no loss of frame synchronization for temperature gradients of $\pm 22^\circ\text{C}/\text{Hr}$.
Storage Temperature:	-32 to +70°C, to 99% Non-Condensing

Note: These specifications are subject to change.

Appendix A. Remote ASCII

A.1 Control Commands

Control Commands are those commands that alter the setup or operating parameters of the converter. The applicable commands are as follows:

HELP	displays all available user commands
STATUS	displays converter status
DATA	displays data formats associated with commands
SHOWRSS	displays Received Signal Strength
SHOWPRI	displays priority settings for the 8 prime converters
SETFREQ	sets the frequency for the current channel
SETGAIN	sets the gain for the current channel
SETCHAN	sets the current channel
SETPRI	sets priorities of converters 1 - 8 respectively
STORE	saves all data under the current channel
RFON	turns RF on
RFOFF	turns RF off
SETATTN	sets the input attenuation for the current channel
CLRFAULT	clears latched faults
AUTO	puts switch back into auto mode
MANUAL	forces the switch to place the converter online and keeps it there
MANBACK	forces the backup to replace the specified converter
RAMGAIN	sets the gain for another/alternate channel
RAMFREQ	sets the frequency for another/alternate channel
ERASE	erases stored status, frequency and gain data upon next reset
RESTART	restarts the converter
LEARN	causes the backup converter to learn about the prime converter(s)
SETSN	sets unit serial number
ENYDAR	password (RADYNE backwards)
UNLOCK	unlocks the unit for factory setup
TOUCHUP	unlocks the unit for factory touchup of the calibration table
DISFAULT	disables faults
ENAFULT	enables faults
LABHELP	display help for factory setup commands
DUMPCAL	-----
RDATTEN	displays the DAC value for a given freq and gain indexes
WRATTEN	writes the given DAC value for a given freq and gain indexes
GAINOFFSET?	displays the Gain Offset value
GAINOFFSET =	sets the Gain Offset value
DMPCHAN	displays the contents of the entire channel table
DMPCAL	displays DAC values in the calibration table for the given freq Index
CURDAC	displays the DAC value used for the unit's current configuration
DACFOR	displays the DAC value used for the given frequency and gain values

A.2 Remote Help Menu (All)

The following command returns information on all remote serial commands. The command is as follows:

@01/HELP<cr>

A single converter or a prime converter in 1 for 8 configuration will return the following:

For Upconverter:

<cr><lf>	
HELP	Show all commands
DATA	Show data associated with commands
STATUS	Show status
RFOFF	Mutes the output
RFON	Un-mutes the output
CLRFAULT	Clears any stored faults
DUMPADC	Dump ADC data
ERASE	Erases saved data when the converter is restarted
RESTART	Restarts the converter
SETCHANcc	Retrieve specified channel
SETFREQffff.t	Set current channel's frequency
SETGAINsgg.g	Set current channel's gain
SETATTNaa	Set converter input attenuation
STORE	Save current channel's frequency & gain
RAMGAINccsgg.g	Set stored gain for the specified channel
RAMFREQccffff.t	Set stored frequency for the specified channel
<cr><lf>	
<cr><lf>	{End of transmission}

For Upconverter:

<cr><lf>	
HELP	Show all commands
DATA	Show data associated with commands
STATUS	Show status
SHOWRSS	Displays the received signal strength
CLRFAULT	Clears any stored faults
DUMPADC	Dump ADC data
ERASE	Erases saved data when the converter is restarted
RESTART	Restarts the converter
SETCHANcc	Retrieve specified channel
SETFREQffff.t	Set current channel's frequency
SETGAINsgg.g	Set current channel's gain
SETATTNaa	Set converter input attenuation
STORE	Save current channel's frequency & gain
RAMGAINccsgg.g	Set stored gain for the specified channel
RAMFREQccffff.t	Set stored frequency for the specified channel
<cr><lf>	
<cr><lf>	{End of transmission}

A prime converter in a 1 for 1 configuration will return the following:

<cr><lf>	
HELP	Show all commands
DATA	Show data associated with commands
STATUS	Show status

RFOFF	Mutes the output
RFON	Un-mutes the output
CLRFAULT	Clears any stored faults
DUMPADC	Dump ADC data
ERASE	Erases saved data when the converter is restarted
RESTART	Restarts the converter
SETCHANcc	Retrieve specified channel
SETFREQfff.t	Set current channel's frequency
SETGAINsgg.g	Set current channel's gain
SETATTNaa	Set converter input attenuation
STORE	Save current channel's frequency & gain
RAMGAINccsgg.g	Set stored gain for the specified channel
RAMFREQccfff.t	Set stored frequency for the specified channel
AUTO	Remote Auto switch
MANUAL	Remote Manual switch
<cr><lf>	{End of transmission}

A backup converter in a 1 for 1 configuration will return the following:

<cr><lf>	
HELP	Show all commands
DATA	Show data associated with commands
STATUS	Show status
RFOFF	Mutes the output
RFON	Un-mutes the output
CLRFAULT	Clears any stored faults
DUMPADC	Dump ADC data
ERASE	Erases saved data when the converter is restarted
RESTART	Restarts the converter
AUTO	Remote Auto switch
MANUAL	Remote Manual switch
LEARN	Backup will learn about Prime converter
<cr><lf>	{End of transmission}

A backup converter in a 1 for 8 configuration will return the following:

<cr><lf>	
HELP	Show all commands
DATA	Show data associated with commands
STATUS	Show status
RFOFF	Mutes the output
RFON	Un-mutes the output
CLRFAULT	Clears any stored faults
DUMPADC	Dump ADC data
ERASE	Erases saved data when the converter is restarted
RESTART	Restarts the converter
SETPRIabcdefgh	Set converter priorities
SHOWPRI	Display converter priorities
LEARN	Backup will learn about selected converters
MANBACKn	Force manual backup of converter n
AUTO	Place the switch in auto mode
<cr><lf>	{End of transmission}

A.3 Status Command (All)

This command returns the current status of the converter. The command is as follows:

@01/STATUS<cr>

A single converter will return the following string of information:

For Upconverter:

```
<cr><lf>
Configuration: Single
Status: {Offline, Warming up/Offline/Setup/Online}
Channel: cc {cc = current channel number, 01 to 30}
Frequency: ffff.fff {ffff.fff = frequency in MHz}
Gain: sgg.g {s = ± and gg.g = gain in dB}
Input Atten: aa dB {aa = input attenuation}
RF: {Off/On}
Stored Faults: {None/Signal Fault/LO Fault/LO Fault, Signal Fault}
Reference: {Internal/External}
<cr><lf>
<cr><lf> {End of transmission}
```

For Upconverter:

```
<cr><lf>
Configuration: Single
Status: {Offline, Warming up/Offline/Setup/Online}
Channel: cc {cc = current channel number, 01 to 30}
Frequency: ffff.fff {ffff.fff = frequency in MHz}
Gain: sgg.g {s = ± and gg.g = gain in dB}
RSS: aa dBm {aa = received signal strength}
Stored Faults: {None/Signal Fault/LO Fault/LO Fault, Signal Fault}
Reference: {Internal/External}
<cr><lf>
<cr><lf> {End of transmission}
```

A prime converter in a 1:1 Switch Configuration will return the following string of information:

```
<cr><lf>
Converter Configuration: One for One Primary
Switch Configuration: {Manually Selected/Manually De-Selected/Auto}
Status: {Faulted, Offline, Warming up/Faulted,
Offline/Setup/Online/Standby}
Channel: cc {cc = current channel number, 01 to 30}
Frequency: ffff.fff {ffff.fff = frequency in MHz}
Gain: sgg.g {s = ± and gg.g = gain in dB}
Input Atten: aa dB {aa = input attenuation}
RF: {Off/On}
Stored Faults: {None/Signal Fault/LO Fault/LO Fault, Signal Fault}
Reference: {Internal/External}
<cr><lf>
<cr><lf> {End of transmission}
```

A backup converter in a 1:1 Switch Configuration will return the following string of information:

```
<cr><lf>
Converter Configuration: One for One Backup
Switch Configuration:      {Manually Selected/Manually De-Selected/Auto}
Status:                   {Faulted, Offline, Warming up/Faulted,
                           Offline/Setup/Online/Standby}
Channel: cc               {cc = current channel number, 01 to 30}
Frequency: ffff.fff      {ffff.fff = frequency in MHz}
Gain: sgg.g              {s = ± and gg.g = gain in dB}
Input Atten: aa dB       {aa = input attenuation}
Backup RF:                {Off/On}
Stored Faults:           {None/Signal Fault/LO Fault/LO Fault, Signal Fault}
Backup Reference:        {Internal/External}
                           <cr><lf>
Switch Faults:           {None/Prime converter not learned/Prime converter polling error}
                           <cr><lf>
                           {End of transmission}
```

A primary converter in a 1:8 Switch configuration will return the following string of information:

```
<cr><lf>
Switch Configuration: One for Eight
Primary Converter Number n {n = primary converter number}
Status:                   {Faulted, Warming up/Faulted/Available}
Channel: cc               {cc = current channel number, 01 to 30}
Frequency: ffff.fff      {ffff.fff = frequency in MHz}
Gain: sgg.g              {s = ± and gg.g = gain in dB}
Input Atten: aa dB       {aa = input attenuation}
RF:                       {Off/On}
Stored Faults:           {None/Signal Fault/LO Fault/LO Fault, Signal Fault}
Reference:                {Internal/External}
                           <cr><lf>
                           {End of transmission}
```

A backup converter in a 1:8 Switch Configuration will return the following string of information:

```
<cr><lf>
backup converter in a One-for-Eight switch configuration
Hot Converter: n         Frequency: ffff.fff Gain: sgg.g Input Atten: aa dB
                           {n = hot converter number} {ffff.fff = frequency in MHz}
                           {s = ± and gg.g = gain in dB} {aa = input attenuation}
Backup Reference:        {Internal/External}
Backup RF:               {Off/On}
Backup Stored Faults:    {None/Signal Fault/LO Fault/LO Fault, Signal Fault}
                           <cr><lf>
Prime 1 is               {not selected/Online with a Priority = n/Online and Faulted with a
                           Priority = n/Offline and Faulted with a Priority = n/Offline and
                           Available with a Priority = n}
                           {n = priority number, 0 - 8}
Prime 2 is               {not selected/Online with a Priority = n/Online and Faulted with a
                           Priority = n/Offline and Faulted with a Priority = n/Offline and
                           Available with a Priority = n}
Prime 3 is               {not selected/Online with a Priority = n/Online and Faulted with a
                           Priority = n/Offline and Faulted with a Priority = n/Offline and
                           Available with a Priority = n}
Prime 4 is               {not selected/Online with a Priority = n/Online and Faulted with a
                           Priority = n/Offline and Faulted with a Priority = n/Offline and
                           Available with a Priority = n}
Prime 5 is               {not selected/Online with a Priority = n/Online and Faulted with a
                           Priority = n/Offline and Faulted with a Priority = n/Offline and
                           Available with a Priority = n}
```

Prime 6 is	{not selected/Online with a Priority = n/Online and Faulted with a Priority = n/Offline and Faulted with a Priority = n/Offline and Available with a Priority = n}
Prime 7 is	{not selected/Online with a Priority = n/Online and Faulted with a Priority = n/Offline and Faulted with a Priority = n/Offline and Available with a Priority = n}
Prime 8 is	{not selected/Online with a Priority = n/Online and Faulted with a Priority = n/Offline and Faulted with a Priority = n/Offline and Available with a Priority = n}
Backup is	{Faulted, Warming up/Faulted/Available/Online for Prime n} {n = backed up prime converter}
<cr><lf>	
Converter	1 2 3 4 5 6 7 8
Learn Status	{F/- } {for 1 - 8} (Dash = Pass, F = Fail)
Polling Status	{F/- } {for 1 - 8} (Dash = Pass, F = Fail)
Relay Status	{F/- } {for 1 - 8} (Dash = Pass, F = Fail)
Switch is in	{Manual mode/Auto mode}
<cr><lf>	{End of transmission}

A.4 Data (All)

This command returns the applicable data formats for the various commands. The command is as follows:

@01/DATA

A single converter, prime converter in a 1:1 switch configuration or prime converter in a 1:8 Switch Configuration will return the following string of information:

For Upconverter:

```
<cr><lf>
cc = channel (01 to 30)
gg.g = gain (-20.0 to +30.0) depending on Input Attenuation
s = sign (+ or -)
ffff = frequency MHz (ffff.0 to ffff.0)      {ffff.0 = frequency in MHz, low end to high end}
t = Kilohertz step ( 0 to 7 for 000 - 875 in 125 kHz increments)
aa = Input Attenuation (00 to 30)
<cr><lf>
<cr><lf>                                {End of transmission}
```

For Upconverter:

```
<cr><lf>
cc = channel (01 to 30)
gg.g = gain (-20.0 to +30.0) depending on Input Attenuation
ffff = frequency MHz (ffff.0 to ffff.0)      {ffff.0 = frequency in MHz, low end to high end}
t = Kilohertz step ( 0 to 7 for 000 - 875 in 125 kHz increments)
<cr><lf>
<cr><lf>                                {End of transmission}
```

A backup converter in a 1:8 Switch Configuration will return the following string of information:

```
<cr><lf>
abcdefgh = Priority settings for converters 1 - 8 respectively
              0 = None. Backup will ignore converter
              1 = Highest priority
              8 = Lowest Priority

<cr><lf>
n = Used with manual backup command MANBACK as follows:
      0 = Places the Backup in Standby mode, all Primes online
      1 - 8 Specifies the Prime to be taken offline and replaced by the
      Backup

<cr><lf>
<cr><lf>                                {End of transmission}
```

A backup converter in a 1:1 Switch Configuration will return the following string of information:

```
<cr><lf>
There are no data specific commands for the backup converter in the one for one switch
configuration
<cr><lf>
<cr><lf>                                {End of transmission}
```

A.5 Show Received Signal Strength Command (Upconverter Only) (S, P1:1, P1:8)

This command will cause the converter to output the Received Signal Strength.

@01/SHOWRSS<cr>

The converter will return the following:

```
<cr><lf>
RSS: vv                                {vv = value for Received Signal Strength}
<cr><lf>
<cr><lf>                                {End of transmission}
```

A.6 Show Priority Command (B1: 8)

This command returns the priority settings for all 8 of the prime converters. The command is as follows:

@01/SHOWPRI

The converter will return the following:

```
<cr><lf>
Converter          1  2  3  4  5  6  7  8
Priority           a  b  c  d  e  f  g  h
                  {abcdefgh = Priority settings for converters 1 - 8 respectively}
<cr><lf>          {End of transmission}
```

A.7 Set Current Channel Frequency Command (S, P1:1, P1:8)

This command alters the stored frequency of the current channel. The command is as follows:

@01/SETFREQffff.t<cr>

The frequency numerical values include four digits for MHz and one digit "t" which indicates the resolution in 125 kHz steps.

The values of "t" are as follows:

t	frequency
0	000 kHz
1	125 kHz
2	250 kHz
3	375 kHz
4	500 kHz
5	625 kHz
6	750 kHz
7	875 kHz

Valid frequency ranges are dependent upon device configuration: To see range for current configuration, send the SETFREQ Command without any data (i.e. "@01SETFREQ<cr>"). This will result in an error message being returned that contains the current freq limits. Frequencies outside this range or frequencies that are of an invalid form will be responded to by the 'illegal frequency' prompt. If the synthesizer is unable to tune to the desired band and frequency, the converter will indicate an LO Fault Condition status indication and will change to an off-line or out-of-service indication.

If successful, the converter will return the following string:

For Upconverter:

```
<cr><lf>
Channel: cc                {cc = current channel number, 01 to 30}
Frequency: ffff.fff       {ffff.fff = frequency in MHz}
Gain: sgg.g               {s = ± and gg.g = gain in dB}
Input Atten: aa dB        {aa = input attenuation}
Stored Faults:            {None/Signal Fault/LO Fault/LO Fault, Signal Fault}
Reference:                {Internal/External}
<cr><lf>
<cr><lf>                   {End of transmission}
```

For Upconverter:

```
<cr><lf>
Channel: cc                {cc = current channel number, 01 to 30}
Frequency: ffff.fff       {ffff.fff = frequency in MHz}
Stored Faults:            {None/Signal Fault/LO Fault/LO Fault, Signal Fault}
Reference:                {Internal/External}
<cr><lf>
<cr><lf>                   {End of transmission}
```

A.8 Set Current Channel Gain Command (S, P1:1, P1:8)

This command alters the stored Gain of the current channel. The command is as follows:

@01/SETGAINsgg.g<cr>

The numeric value 's' indicates the 'plus' sign (+) or 'minus' sign (-). The numeric value 'g' consists of three digits indicating gain. Valid Gain ranges are dependent upon device configuration: To see range for current configuration, send the setgain command without any data (i.e. "@SETGAIN<cr>"). This will result in an error message being returned that contains the current gain limits. Gain values outside this range will be responded to by the 'ILLEGAL GAIN' prompt.

If successful, the converter will return the following string:

For Upconverter:

```
<cr><lf>
Channel: cc           {cc = current channel number, 01 to 30}
Frequency: ffff.fff  {ffff.fff = frequency in MHz}
Gain: sgg.g          {s = ± and gg.g = gain in dB}
Input Atten: aa dB   {aa = input attenuation}
RF:                  {Off/On}
Stored Faults:       {None/Signal Fault/LO Fault/LO Fault, Signal Fault}
Reference:           {Internal/External}
<cr><lf>
<cr><lf>             {End of transmission}
```

For Upconverter:

```
<cr><lf>
Channel: cc           {cc = current channel number, 01 to 30}
Frequency: ffff.fff  {ffff.fff = frequency in MHz}
Gain: sgg.g          {s = ± and gg.g = gain in dB}
RSS: nn              {n = current Received Signal Strength}
Stored Faults:       {None/Signal Fault/LO Fault/LO Fault, Signal Fault}
Reference:           {Internal/External}
<cr><lf>
<cr><lf>             {End of transmission}
```

A.9 Channel Command (S, P1:1, P1:8)

This command changes the Current Channel and thus the Gain and Frequency of the converter to one of the 30 preprogrammed channels. The command is as follows:

@01/SETCHANcc<cr>

Where 'cc' represents a channel number from 01 - 30.

If successful, the converter will return the following string:

For Upconverter:

```

<cr><lf>
Channel: cc                {cc = current channel number, 01 to 30}
Frequency: ffff.fff       {ffff.fff = frequency in MHz}
Gain: sgg.g               {s = ± and gg.g = gain in dB}
Input Atten: aa dB        {aa = input attenuation}
RF:                        {Off/On}
Stored Faults:            {None/Signal Fault/LO Fault/LO Fault, Signal Fault}
Reference:                {Internal/External}
<cr><lf>
                                <cr><lf>                {End of transmission}

```

For Upconverter:

```

<cr><lf>
Channel: cc                {cc = current channel number, 01 to 30}
Frequency: ffff.fff       {ffff.fff = frequency in MHz}
Gain: sgg.g               {s = ± and gg.g = gain in dB}
RSS: nn                   {n = current Received Signal Strength}
Stored Faults:            {None/Signal Fault/LO Fault/LO Fault, Signal Fault}
Reference:                {Internal/External}
<cr><lf>
<cr><lf>                    {End of transmission}

```

A.10 Set Priority (B1: 8)

This command is used to set the priorities of converters 1 - 8 respectively. The command is as follows:

```
@01/SETPRIabcdefgh<cr>
```

where:

```

0 = No priority (the converter will be ignored)
1 = Highest priority
8 = Lowest Priority

```

For example: @01/SETPRI47300000 will cause the following to occur:

```

Converter 1 will have priority 4
Converter 2 will have priority 7
Converter 3 will have priority 3
Converters 4 - 8 will be ignored

```

If successful, the converter will not return a string.

If unsuccessful the converter will return the following string:

```

<cr><lf>
Invalid Priority Sequence
Use command 'SETPRIabcdefgh' where abcdefgh = priority settings for converters 1 - 8
respectively
0 = None. Backup will ignore converter
1 = Highest priority
8 = Lowest Priority
<cr><lf>                {End of transmission}

```

A.11 Store Current Channel Settings (S, P1: 1, P1: 8)

This command stores the current settings for the Frequency and Gain into the channel table for the currently selected channel. The command is as follows:

@01/STORE<cr>

If successful, the converter will return the following string:

```
<cr><lf>
Channel: cc                {cc = current channel number, 01 to 30}
Frequency: ffff.fff       {ffff.fff = frequency in MHz}
Gain: sgg.g               {s = ± and gg.g = gain in dB}
Stored Faults:           {None/Signal Fault/LO Fault/LO Fault, Signal Fault}
Reference:               {Internal/External}
<cr><lf>
<cr><lf>                  {End of transmission}
```

A.12 RF On/Off Command (Upconverter Only) (All)

These commands control the converter's output. The commands are as follows:

@01/RFON<cr>

@01/RFOFF<cr>

Note: *If the converter is faulted, any attempt to turn on the RF without first clearing the fault will fail.*

If successful, the converter will return the following string:

For backup converter:

```
Backup RF: {Off/On}
Stored Faults:           {None/Signal Fault/LO Fault/LO Fault, Signal Fault}
<cr><lf>
<cr><lf>                  {End of transmission}
```

For Single or Primary Converter:

```
RF: {Off/On}
Stored Faults:           {None/Signal Fault/LO Fault/LO Fault, Signal Fault}
<cr><lf>
<cr><lf>                  {End of transmission}
```

A.13 Change Input Attenuation Command (Upconverter Only) (S, P1: 1, P1: 8)

This command alters the converter-input attenuation. The commands are as follows:

@01/SETATTNaa<cr>

Where aa is the input attenuation (00 - 30)

If successful, the converter will return the following string:

```

<cr><lf>
Channel: cc                {cc = current channel number, 00 to 30}
Frequency: ffff.fff       {ffff.fff = frequency in MHz}
Gain: sgg.g               {s = ± and gg.g = gain in dB}
Input Atten: aa dB        {aa = input attenuation}
RF:                       {Off/On}
Stored Faults:            {None/Signal Fault/LO Fault/LO Fault, Signal Fault}
Reference:                {Internal/External}
<cr><lf>
<cr><lf>                  {End of transmission}

```

A.14 Clear Faults Command (All)

This command clears any stored faults. The command is as follows:

```
@01/CLRFAULT<cr>
```

The converter will not return a string.

A.15 Auto Mode Command (P1: 1, B1: 1, B1: 8)

This command allows the operator to put the switch back into Auto Mode. The command is as follows:

```
@01/AUTO<cr>
```

Note: For a 1:1 Switch configuration, if the front panel switch is accidentally left in the Manual Mode, from the Remote Port send a manual command to the converter that is 'Manually Deselected,' i.e.; the one that is NOT selected. Then send an Auto Command to the same converter and the switch will now be back in Auto Mode. For a 1:8 Switch configuration, send the Auto Mode command to the backup converter.

If successful, the converter will not return a string.

A.16 Manual Mode Command (P1: 1, B1: 1)

This command allows the operator to force the switch to put the converter online and keep it there. This command simulates the manual selection switch on the front panel. The command is as follows:

```
@01/MANUAL<cr>
```

Note: For a 1:1 Switch configuration, if the front panel switch is accidentally left in the Manual Mode, from the Remote Port send a manual command to the converter that is 'Manually Deselected,' i.e.; the one that is NOT selected. Then send an Auto Command to the same converter and the switch will now be back in Auto Mode.

If successful, the converter will not return a string.

A.17 Manual Backup Command (B1: 8)

This command allows the operator to force the switch to put the Backup online for the specified converter and keeps it there. This command simulates the manual backup selection switches on the front panel of the 1:8 Switch. The command is as follows:

@01/MANBACKn<cr>

Where:

n = 0 Forces the Backup to Standby Mode, all Primes online

n = 1..8 Specifies the converter the Backup is to replace

If successful, the converter will not return a string.

If unsuccessful the converter will return one of the following strings:

```
<cr><lf>
Invalid Converter ID. Data should be 0 - 8 where
0 = backup converter and 1 - 8 = Prime Converters
<cr><lf>                                {End of transmission}
```

```
<cr><lf>
Unable to perform manual backup
Selected converter has a priority = 0
<cr><lf>                                {End of transmission}
```

```
<cr><lf>
Unable to perform manual backup
Selected converter was not successfully learned
<cr><lf>                                {End of transmission}
```

A.18 Set Stored Gain For a Specified Channel (S, P1: 1, P1: 8)

This command allows the user to set the Stored Gain for a specified channel. The command is as follows:

@01/RAMGAINccsgg.g<cr>

If successful, the converter will not return a string.

A.19 Set Stored Frequency For a Specified Channel (S, P1: 1, P1: 8)

This command allows the user to set the Stored Frequency for a specified channel other than the current one. The command is as follows:

@01/RAMFREQccffff.t<cr>

If successful, the converter will not return a string.

A.20 Erase (All)

This command allows the user to erase the Stored Status, Frequency and Gain Information the next time the unit is reset. The command is as follows:

```
@01/ERASE<cr>
```

If successful, the converter will not return a string.

A.21 Restart (All)

This command allows the user to reset/restart the converter. The command is as follows:

```
@01/RESTART<cr>
```

If successful, the converter will not return a string.

A.22 Learn (B1: 1, B1: 8)

In a 1:1 Switch configuration, this command will cause the backup converter to 'Learn' about the Prime converter.

In a 1:8 configuration, the backup converter will 'Learn' about the Prime converters that have a priority >0. As the backup converter polls the Prime(s), the learning status will be output via the serial port. The command is as follows:

```
@01/LEARN<cr>
```

A backup converter in a 1:1 Switch Configuration will return one of the following strings of information:

```
<cr><lf>
```

```
Learning FAILED because the Prime gave an invalid response/Prime did not respond/Prime's
incompatible with the Backup/Prime's RF is turned off}
```

```
<cr><lf>                                {End of transmission}
```

```
<cr><lf>
```

```
Prime converter was successfully learned
```

```
<cr><lf>                                {End of transmission}
```

A backup converter in a 1:8 Switch Configuration will return the following string of information:

```
<cr><lf>
```

```
Converter 1                                {FAILED because of an invalid response/FAILED because it did
not respond/FAILED because it's incompatible with the
backup/FAILED because it's RF is turned off/was successfully
learned/was not selected}
```

```
Converter 2                                {FAILED because of an invalid response/FAILED because it did
not respond/FAILED because it's incompatible with the
backup/FAILED because it's RF is turned off/was successfully
learned/was not selected}
```

```
Converter 3                                {FAILED because of an invalid response/FAILED because it did
not respond/FAILED because it's incompatible with the
backup/FAILED because it's RF is turned off/was successfully
learned/was not selected}
```

Converter 4	{FAILED because of an invalid response/FAILED because it did not respond/FAILED because it's incompatible with the backup/FAILED because it's RF is turned off/was successfully learned/was not selected}
Converter 5	{FAILED because of an invalid response/FAILED because it did not respond/FAILED because it's incompatible with the backup/FAILED because it's RF is turned off/was successfully learned/was not selected}
Converter 6	{FAILED because of an invalid response/FAILED because it did not respond/FAILED because it's incompatible with the backup/FAILED because it's RF is turned off/was successfully learned/was not selected}
Converter 7	{FAILED because of an invalid response/FAILED because it did not respond/FAILED because it's incompatible with the backup/FAILED because it's RF is turned off/was successfully learned/was not selected}
Converter 8	{FAILED because of an invalid response/FAILED because it did not respond/FAILED because it's incompatible with the backup/FAILED because it's RF is turned off/was successfully learned/was not selected}
<cr><lf>	{End of transmission}

A.23 Read DAC Value by Index (All)

This command is used to display the contents of the calibration table (DAC value) for the given Frequency Index (ff) and the given Attenuation Index (aa). The command is as follows:

```
@01/RDATTENff aa<cr>
```

Note: Parameters are not actual values for frequency and attenuation but the actual index into the various arrays that make up the power calibration table: The valid ranges for these values are dependent on device type and configuration.

If successful, the converter will return the following string:

```
<cr><lf>
Cal Data = dddd:           {dddd is the DAC value}
<cr><lf>
<cr><lf>                   {End of transmission}
```

A.24 Write DAC Value by Index (All)

This command is used to set the contents of the calibration table (DAC value) for the given Frequency Index (ff) and the given Attenuation Index (aa) to the given value (vvvv). The command is as follows:

```
@01/WRATTENff aa vvvv<cr>
```

Note: Parameters are not actual values for frequency and attenuation but the actual index into the various arrays that make up the power calibration table: The valid ranges for these values are dependant on device type and configuration.

If successful, the converter will not return a string.

A.25 Get Gain Offset (Upconverter Only)

This command displays the value for the Gain Offset. The command is as follows:

```
@01/GAINOFFSET?<cr>
```

If successful, the converter will return the following string:

```
<cr><lf>
Gain Offset Value = gg:      {gg is the gain offset value}
<cr><lf>
<cr><lf>                      {End of transmission}
```

A.26 Set Gain Offset (Upconverter Only)

This command sets the value for the Gain Offset. The command is as follows:

```
@01/GAINOFFSET = <cr>
```

If successful, the converter will return the following string:

```
<cr><lf>
Gain Offset Value = gg:      {gg is the gain offset value}
<cr><lf>
<cr><lf>                      {End of transmission}
```

A.27 Dump Channel Table (All)

This command returns the contents of the Channel Table. The command is as follows:

```
@01/DMPCHAN<cr>
```

If successful, the converter will return the following string:

```
<cr><lf>
[ffff.f,sgg.g] [ffff.f,sgg.g] [ffff.f,sgg.g] [ffff.f,sgg.g] [ffff.f,sgg.g]
[ffff.f,sgg.g] [ffff.f,sgg.g] [ffff.f,sgg.g] [ffff.f,sgg.g] [ffff.f,sgg.g]
[ffff.f,sgg.g] [ffff.f,sgg.g] [ffff.f,sgg.g] [ffff.f,sgg.g] [ffff.f,sgg.g]
[ffff.f,sgg.g] [ffff.f,sgg.g] [ffff.f,sgg.g] [ffff.f,sgg.g] [ffff.f,sgg.g]
[ffff.f,sgg.g] [ffff.f,sgg.g] [ffff.f,sgg.g] [ffff.f,sgg.g] [ffff.f,sgg.g]
<cr><lf>
<cr><lf>                      {End of transmission}
```

where:

```
ffff.f      {f = frequency for channel entry]
sgg.g       {s = '+' or '-' : gg.g = Gain for channel entry]
```

A.28 Dump Calibration Table Set (All)

This command returns the contents (DAC values for all gains) of the Power Calibration Table for the given Frequency Index. The command is as follows:

```
@01/DMPCALff<cr>
```

where:

ff {Index into the frequency array portion of the table}

If successful, the converter will return the following string:

```
<cr><lf>
[ffff.f,sgg.g] [ffff.f,sgg.g] [ffff.f,sgg.g] [ffff.f,sgg.g] [ffff.f,sgg.g]
[ffff.f,sgg.g] [ffff.f,sgg.g] [ffff.f,sgg.g] [ffff.f,sgg.g] [ffff.f,sgg.g]
[ffff.f,sgg.g] [ffff.f,sgg.g] [ffff.f,sgg.g] [ffff.f,sgg.g] [ffff.f,sgg.g]
[ffff.f,sgg.g] [ffff.f,sgg.g] [ffff.f,sgg.g] [ffff.f,sgg.g] [ffff.f,sgg.g]
[ffff.f,sgg.g] [ffff.f,sgg.g] [ffff.f,sgg.g] [ffff.f,sgg.g] [ffff.f,sgg.g]
<cr><lf>
<cr><lf>                                {End of transmission}
```

where:

ffff.f {f = frequency for channel entry}
 sgg.g {s = '+' or '-' : gg.g = Gain for channel entry}

A.29 Get Current DAC Value (All)

This command returns the DAC value in use for the unit's current configuration (Values of Frequency and Gain). The command is as follows:

@01/CURDAC<cr>

If successful, the converter will return the following string.:

```
<cr><lf>
DAC Value = dddd          {dddd = DAC Value}
<cr><lf>
<cr><lf>                  {End of transmission}
```

A.30 Get DAC Value for Frequency and Gain (All)

This command returns the DAC value to be used for the given values of frequency and gain. The command is as follows:

@01/DACFORffff.f gg.g<cr>

where:

ffff.f {f = frequency }
 sgg.g {s = '+' or '-' : gg.g = Gain }

If successful, the converter will return the following string.:

```
<cr><lf>
DAC Value = dddd          {dddd = DAC Value}
<cr><lf>
<cr><lf>                  {End of transmission}
```

A.31 Error Messages

Bad address

```
<cr><lf>
INVALID ADDRESS
<cr><lf>
<cr><lf>                                {End of transmission}
```

Bad command

```
<cr><lf>
ILLEGAL COMMAND
<cr><lf>
<cr><lf>                                {End of transmission}
```

Not in backup 1 to 1

```
<cr><lf>
Command is not valid for the backup converter
<cr><lf>                                {End of transmission}
```

Not in backup 1 - 8

```
<cr><lf>
Command is not valid for the backup converter
in a 1 for 8 configuration
<cr><lf>                                {End of transmission}
```

Only in backup 1 - 8

```
<cr><lf>
Command is ONLY valid for the backup converter
in a 1 for 8 configuration
<cr><lf>                                {End of transmission}
```

Only in backup 1 to 1

```
<cr><lf>
Command is ONLY valid in a 1 for 1 switch configuration
<cr><lf>                                {End of transmission}
```

Only in backup

```
<cr><lf>
Command is ONLY valid for the backup converter
<cr><lf>                                {End of transmission}
```

Bad channel

```
<cr><lf>
ILLEGAL CHANNEL (sb 01 to 30)
<cr><lf>
<cr><lf>                                {End of transmission}
```

Bad frequency

```

<cr><lf>
ILLEGAL FREQUENCY
      (sb ffff.0 to ffff.0)      {ffff.0 = frequency in MHz, low end to high end}
<cr><lf>
<cr><lf>                          {End of transmission}

```

Bad gain

```

<cr><lf>
ILLEGAL GAIN
      (sb sgg.g to sgg.g)      {s = ± and gg.g = gain in dB, low end to high end, were range is
                                (- (Input Atten) + 10) to (- (Input Atten) + 30)}
<cr><lf>
<cr><lf>                          {End of transmission}

```

Bad input attenuation

```

<cr><lf>
ILLEGAL INPUT ATTENUATION (sb 00 to 30)
<cr><lf>
<cr><lf>                          {End of transmission}

```

Converter is faulted

```

<cr><lf>
Unable to turn RF on. Check converter status
<cr><lf>                          {End of transmission}

```

Remote mode only

```

<cr><lf>
Command valid in REMOTE mode only
<cr><lf>                          {End of transmission}

```

Invalid Data

```

<cr><lf>
INVALID DATA FIELD
<cr><lf>                          {End of transmission}

```

Invalid priority data

```

<cr><lf>
Invalid Priority Sequence
Use command 'SETPRIabcdefgh' where abcdefgh = priority settings for converters 1 - 8
respectively

```

```

0 = None. Backup will ignore converter
1 = Highest priority
8 = Lowest Priority
<cr><lf>                          {End of transmission}

```

Appendix B. Remote RLLP



When new features are added to Comtech EF Data equipment, the control parameters are appended to the end of the Non-Volatile Section of the Remote Communications Specification, and status of the features, if any, are added at the end of the Volatile Section. If a remote M&C queries two pieces of Comtech EF Data equipment with different revision software, they could respond with two different sized packets. The remote M&C **MUST** make use of the non-volatile count value to index to the start of the Volatile Section. If the remote M&C is not aware of the newly added features to the product, it should disregard the parameters at the end of the Non-Volatile Section and index to the start of the Volatile Section.

Before creating any software based on the information contained in this document, contact the Comtech EF Data Customer Service Department (480-333-4357) to find out if the software revision for that piece of equipment is current and that no new features have been added since the release of this document.

B.1 Converter Opcode Command Set

The converter opcode command set is listed below:

Command	Opcode
Query control mode	2404h
Query time	240Eh
Query date	240Fh
Query time and date	2410h
Query software revision number	3000h

Query firmware part number and release date	3001h
Query converter status	3002h
Query converter configuration	3003h
Query switch status	3010h
Query switch configuration	3011h
Command converter set control mode	2600h
Command converter clear latched alarms	2C03h
Command converter set time	2C04h
Command converter set date	2C05h
Command converter set time and date	2C06h
Command converter set terminal emulation	2C0Bh
Command converter set terminal baud rate	2C0Ch
Command converter set frequency for the current channel	3020h
Command converter set gain for the current channel	3021h
Command converter set frequency for the given channel	3022h
Command converter set gain for the given channel	3023h
Command converter set channel	3024h
Command converter set carrier control	3025h
Command converter set input attenuation	3026h
Command converter set alarm masks	3027h
Command switch set backup mode	3040h
Command switch force a manual backup	3041h
Command switch set learn configuration	3042h
Command switch backup test configuration	3043h
Command switch set compensation control	3044h
Command switch set converter compensation	3045h
Command switch set all converter compensations	3046h
Command switch set converter priority	3047h
Command switch set all converter priorities	3048h
Command switch set alarm masks	3049h
Command switch set fault delay	304Ah

B.2 Converter Queries

Opcode: <2404H> **Query control mode**

Query Response		
<1>	Control Mode	0=Local, 1=Terminal, 2=Remote, 3=Ethernet

Opcode: <240EH> **Query time**

Query Response		
<1>	Hour	0 – 23
<1>	Minute	0 – 59
<1>	Second	0 – 59

Opcode: <240FH> **Query date**

Query Response		
<1>	Year	0 – 99
<1>	Month	0 – 11
<1>	Day	0 – 30

Opcode: <2410H> **Query time and date**

Query Response		
<1>	Year	0 – 99
<1>	Month	0 – 11
<1>	Day	0 – 30
<1>	Hour	0 – 23
<1>	Minute	0 – 59
<1>	Second	0 – 59

Opcode: <3000H> **Query software revision number**

Query Response		
<2>	Revision Number	Binary value with implied decimal point, 120 means release 1.20

Opcode: <3001H> **Query firmware part number and release date**

Query Response		
<9>	Part Number String	FW/4835xx, xx represents the release version, example –B
<9>	Release Date String	Release date in the ddMMMyyyy format, ex 19MAR2004

Opcode: <3002H> **Query converter status**

Query Response		
<4>	Signal strength	Reserved. Not implemented
<1>	Carrier Status	0=OFF, 1=ON
<1>	Converter Status	0 = Standby or Available for a primary 1FN on a backward compatible switch, 1 = Faulted, Offline or Faulted for a primary 1FN on a backward compatible switch, 2 = Online, 3 = Faulted, Online, 4 = Setup
<1>	Switch Status	0=Backward Compatible Switch, 1=Prime Chain Switch, 2=Backup Chain Switch, 3=No Switch
<1>	Converter Config	0=Single Converter, 1=Primary1F1, 2=Backup1F1, 3=Primary1FN, 4=Backup1FN
<1>	Converter Type	0=Down, 1=Up
<1>	Converter Band	0=C-Band, 1=Ku-Band, 2=Ka-Band
<1>	Frequency Type	0=70 MHz, 1=140 MHz
<1>	Reference Type	0=Internal, 1=External
<1>	Major Alarm Status	Bit 0 = LO Fault Bit 1 = Signal Fault Bits 2-7 = Spares 0 = PASS, 1 = FAIL
<1>	Minor Alarm Status	Bit 0 = RF Detect Fault Bit 1 = IF Detect Fault Bits 2-7 = Spares 0 = PASS, 1 = FAIL
<1>	Latched Major Alarm Status	Bit 0 = LO Fault Bit 1 = Signal Fault Bits 2-7 = Spares 0 = Not Latched, 1 = Latched
<1>	Latched Minor Alarm Status	Bit 0 = RF Detect Fault Bit 1 = IF Detect Fault Bits 2-7 = Spares 0 = Not Latched, 1 = Latched
<1>	Inter Converter Communication Address	0 = Backup for Chain Switch, 1 = Prime 1 for 1F8 or Chain Switch, 2 = Prime 2 for 1F8 or Chain Switch, 3 = Prime 3 for 1F8 or Chain Switch, 4 = Prime 4 for 1F8 or Chain Switch, 5 = Prime 5 for 1F8 or Chain Switch, 6 = Prime 6 for 1F8 or Chain Switch, 7 = Prime 7 for 1F8 or Chain Switch, 8 = Prime 8 for 1F8 or Chain Switch, 9 = Backup for 1F8, 10 = Backup for 1F1, 11 = Primary for 1F1, 255 = Stand Alone
<1>	Inter Converter Communication	Bit 0-3 = Band Down-Band: 0 through 5

	Converter Type	0 = Normal C-Band, 1 = Extended C-Band, 2 = Normal Ku-Band, 3 = Normal American Ku-Band, 4 = India High C-Band, 5 = European Ku-Band Up-Band: 0 through 4 0 = Normal C-Band, 1 = Extended C-Band, 2 = Normal Ku-Band, 3 = Normal Ku-Band, 4 = India High C-Band Bit 4 = 1 KHz Step, 0 = No, 1 = Yes Bit 5 = Spare, Not Used Bit 6 = Normal/Custom, 0 = Normal, 1 = Custom Bit 7 = Down/Up, 0 = Down, 1 = Up
<1>	Filter Status Type (RX Filter Status)	0 = Low Band Filter, 1 = High Band Filters RF + Ku < 9650 MHz

Opcode: <3003H> **Query converter configuration**

Query Response		
<4>	Frequency	Binary value in 125 KHz steps
<4>	Gain	-20.0 dB to +30.0 dB depending on input attenuator setting
<1>	Input Attenuation	0 through 31, Up converter only
<1>	Channel	Current channel, 1 through 30
<1>	Carrier Control	0=Off, 1=On
<1>	Reference Type	0=Internal, 1=External
<1>	Major Alarm Mask	Bit 0 = LO Fault Bit 1 = Signal Fault Bits 2-7 = Spares (0 = Mask, 1 = Allow)
<1>	Minor Alarm Mask	Bit 0 = RF Detect Fault Bit 1 = IF Detect Fault Bit 2-7 = Spares (0 = Mask, 1 = Allow)

B.3 Switch Queries

Opcode: <3010H> **Query switch status**

Query Response		
<1>	Major Alarm Status	Bit 0 = Relay Fault Bit 1 = Backup Fault Bit 2 = No Backup Fault Bit 3 = Polling Fault Bits 4-7 = Spares 0 = Pass, 1 = Fail
<1>	Minor Alarm Status	Bit 0 = Learned Fault Bit 1 = Backup Test Fault

		Bit 2 = Configuration Changed Fault Bits 3-7 = Spares 0 = Pass, 1 = Fail
<1>	Latched Major Alarm Status	Bit 0 = Relay Fault Bit 1 = Backup Fault Bit 2 = No Backup Fault Bit 3 = Polling Fault Bits 4-7 = Spares 0 = Not Latched, 1 = Latched
<1>	Latched Minor Alarm Status	Bit 0 = Learned Fault Bit 1 = Backup Test Fault Bit 2 = Configuration Changed Fault Bits 3-7 = Spares 0 = Not Latched, 1 = Latched
<1>	Fault Status	Bit 0 = Prime 1 Fault Status Bit 1 = Prime 2 Fault Status Bit 2 = Prime 3 Fault Status Bit 3 = Prime 4 Fault Status Bit 4 = Prime 5 Fault Status Bit 5 = Prime 6 Fault Status Bit 6 = Prime 7 Fault Status Bit 7 = Prime 8 Fault Status 0 = PASS, 1 = FAIL
<1>	Relay Status	Bit 0 = Prime 1 Relay Status Bit 1 = Prime 2 Relay Status Bit 2 = Prime 3 Relay Status Bit 3 = Prime 4 Relay Status Bit 4 = Prime 5 Relay Status Bit 5 = Prime 6 Relay Status Bit 6 = Prime 7 Relay Status Bit 7 = Prime 8 Relay Status 0 = ON, 1 = OFF
<1>	Config Changed Status	Bit 0 = Prime 1 Configuration Changed Status Bit 1 = Prime 2 Configuration Changed Status Bit 2 = Prime 3 Configuration Changed Status Bit 3 = Prime 4 Configuration Changed Status Bit 4 = Prime 5 Configuration Changed Status Bit 5 = Prime 6 Configuration Changed Status Bit 6 = Prime 7 Configuration Changed Status Bit 7 = Prime 8 Configuration Changed Status 0 = NO, 1 = YES
<1>	Backup Test Status	Bit 0 = Prime 1 Backup Test Status Bit 1 = Prime 2 Backup Test Status Bit 2 = Prime 3 Backup Test Status Bit 3 = Prime 4 Backup Test Status Bit 4 = Prime 5 Backup Test Status Bit 5 = Prime 6 Backup Test Status Bit 6 = Prime 7 Backup Test Status Bit 7 = Prime 8 Backup Test Status 0 = PASS, 1 = FAIL
<1>	Power Sense	Valid Only in a 1FN Configuration

		Bit 0 = Prime 1 Power Sense Status Bit 1 = Prime 2 Power Sense Status Bit 2 = Prime 3 Power Sense Status Bit 3 = Prime 4 Power Sense Status Bit 4 = Prime 5 Power Sense Status Bit 5 = Prime 6 Power Sense Status Bit 6 = Prime 7 Power Sense Status Bit 7 = Prime 8 Power Sense Status 0 = NO, 1 = YES
<1>	Prime Status (primary 1FN on a backward compatible switch)	Bit 0 = Prime 1 Status Bit 1 = Prime 2 Status Bit 2 = Prime 3 Status Bit 3 = Prime 4 Status Bit 4 = Prime 5 Status Bit 5 = Prime 6 Status Bit 6 = Prime 7 Status Bit 7 = Prime 8 Status 0 = Offline, 1 = Online
<2>	Reserved	
<1>	Backed up Prime	0 to 8, backed up converter, 0 means no backup in progress
<1>	Hot standby Prime	0 to 8, prime in hot standby, 0 means no hot standby in progress
<1>	Chain Card Present	Valid Only for chain switching systems Bit 0 = Prime 1 Chain Card Present Status Bit 1 = Prime 2 Chain Card Present Status Bit 2 = Prime 3 Chain Card Present Status Bit 3 = Prime 4 Chain Card Present Status Bit 4 = Prime 5 Chain Card Present Status Bit 5 = Prime 6 Chain Card Present Status Bit 6 = Prime 7 Chain Card Present Status Bit 7 = Prime 8 Chain Card Present Status 0 = NOT PRESENT, 1 = PRESENT

Opcode: <3011H>

Query switch configuration

Query Response		
<2>	Prime 1 Compensation	-50..50, Implied decimal point corresponds to -5.0 to 5.0 dBm
<2>	Prime 2 Compensation	-50..50, Implied decimal point corresponds to -5.0 to 5.0 dBm
<2>	Prime 3 Compensation	-50..50, Implied decimal point corresponds to -5.0 to 5.0 dBm
<2>	Prime 4 Compensation	-50..50, Implied decimal point corresponds to -5.0 to 5.0 dBm
<2>	Prime 5 Compensation	-50..50, Implied decimal point corresponds to -5.0 to 5.0 dBm
<2>	Prime 6 Compensation	-50..50, Implied decimal point corresponds to -5.0 to 5.0 dBm
<2>	Prime 7	-50..50, Implied decimal point corresponds to -5.0 to 5.0

	Compensation	dBm
<2>	Prime 8 Compensation	-50..50, Implied decimal point corresponds to -5.0 to 5.0 dBm
<2>	Fault Delay	50..10000, value in msec
<2>	No Fault Delay	Reserved
<1>	Compensation Control	0=Disable, 1=Enable
<1>	Backup Mode	0=Manual, 1 = Auto Non Revertive, 2 = Auto Revertive
<1>	Prime To Backup Test	1 = Prime 1, 2 = Prime 2, 3 = Prime 3, 4 = Prime 4, 5 = Prime 5, 6 = Prime 6, 7 = Prime 7, 8=Prime 8, 9=All Primes, converter must be present
<1>	Prime To Backup	0 = Un back, 1 = Backup Prime 1, 2 = Backup Prime 2, 3 = Backup Prime 3, 4 = Backup Prime 4, 5 = Backup Prime 5, 6 = Backup Prime 6, 7 = Backup Prime 7, 8=Backup Prime 8, converter must be present
<1>	Prime To Learn	1 = Prime 1, 2 = Prime 2, 3 = Prime 3, 4 = Prime 4, 5 = Prime 5, 6 = Prime 6, 7 = Prime 7, 8=Prime 8, 9=All Primes, converter must be present
<1>	Prime 1 Priority	0 to 8 (0 means not part of the backup pool)
<1>	Prime 2 Priority	0 to 8 (0 means not part of the backup pool)
<1>	Prime 3 Priority	0 to 8 (0 means not part of the backup pool)
<1>	Prime 4 Priority	0 to 8 (0 means not part of the backup pool)
<1>	Prime 5 Priority	0 to 8 (0 means not part of the backup pool)
<1>	Prime 6 Priority	0 to 8 (0 means not part of the backup pool)
<1>	Prime 7 Priority	0 to 8 (0 means not part of the backup pool)
<1>	Prime 8 Priority	0 to 8 (0 means not part of the backup pool)
<1>	Major Alarm Mask	Bit 0 = Relay Fault Bit 1 = Backup Fault Bit 2 = No Backup Fault Bit 3 = Polling Fault Bits 4-7 = Spares (0 = Mask, 1 = Allow)
<1>	Minor Alarm Mask	Bit 0 = Learned Fault Bit 1 = Backup Test Fault Bit 2 = Configuration Changed Fault Bits 3-7 = Spares (0 = Mask, 1 = Allow)
<1>	Learn Status	Bit 0 = Prime 1 Bit 1 = Prime 2 Bit 2 = Prime 3 Bit 3 = Prime 4 Bit 4 = Prime 5 Bit 5 = Prime 6 Bit 6 = Prime 7 Bit 7 = Prime 8 0 = Not Learned, 1 = Learned

B.4 Converter Commands

Opcode: <2600H> **Command control mode**

<1>	Mode	0=Local, 1=Terminal, 2=Remote, 3=Ethernet
-----	------	--

Opcode: <2C03H> **Command clear latched alarms**

(No Command Data)

Opcode: <2C04H> **Command set time**

<1>	Hour	0 – 23
<1>	Minute	0 – 59
<1>	Second	0 – 59

Opcode: <2C05H> **Query set date**

<1>	Year	0 – 99
<1>	Month	0 – 11
<1>	Day	0 – 30

Opcode: <2C06H> **Command set time and date**

<1>	Year	0 – 99
<1>	Month	0 – 11
<1>	Day	0 – 30
<1>	Hour	0 – 23
<1>	Minute	0 – 59
<1>	Second	0 – 59

Opcode: <2C0BH> **Command set terminal emulation**

<1>	Emulation	0=Adds VP, 1=VT100, 2=WYSE50
-----	-----------	---------------------------------

Opcode: <2C0CH> **Command set terminal baud rate**

<1>	Baud rate	0=Baud 2400, 1=Baud 9600, 2=Baud 19200
-----	-----------	---

Opcode: <3020H> **Command set frequency for the current channel**

<4>	Frequency	Binary value in 125 KHz steps
-----	-----------	-------------------------------

Opcode: <3021H> **Command set gain for the current channel**

<4>	Gain	-20.0 dB to +30.0 dB depending on input attenuator setting
-----	------	--

Opcode: <3022H> **Command set frequency for the given channel**

<4>	Frequency	Binary value in 125 KHz steps
<1>	Channel	1 through 30

Opcode: <3023H> **Command set gain for the given channel**

<4>	Gain	-20.0 dB to +30.0 dB depending on input attenuator setting
<1>	Channel	1 through 30

Opcode: <3024H> **Command set channel**

<1>	Channel	1 through 30
-----	---------	--------------

Opcode: <3025H> **Command set carrier control**

<1>	Carrier Control	0=Off, 1=On
-----	-----------------	-------------

Opcode: <3026H> **Command set input attenuation**

<1>	Input Attenuation	0 through 31, Up converter only
-----	-------------------	---------------------------------

Opcode: <3027H> **Command set converter alarm masks**

<1>	Major Alarm Mask	Bit 0 = LO Fault Bit 1 = Signal Fault Bits 2-7 = Spares (0 = Mask, 1 = Allow)
-----	------------------	--

<1>	Minor Alarm Mask	Bit 0 = RF Detect Fault Bit 1 = IF Detect Fault Bit 2-7 = Spares (0 = Mask, 1 = Allow)
-----	------------------	---

B.5 Switch Commands

Opcode: <3040H> **Command set backup mode**

<1>	Backup Mode	0=Manual, 1=Auto Non Revertive, 2=Auto Revertive
-----	-------------	--

Opcode: <3041H> **Command force a manual backup**

<1>	Prime To Backup	0 = Un back, 1 = Backup Prime 1, 2 = Backup Prime 2, 3 = Backup Prime 3, 4 = Backup Prime 4, 5 = Backup Prime 5, 6 = Backup Prime 6, 7 = Backup Prime 7, 8=Backup Prime 8, converter must be present
-----	-----------------	--

Opcode: <3042H> **Command learn converter configuration**

<1>	Prime To Learn	1 = Prime 1, 2 = Prime 2, 3 = Prime 3, 4 = Prime 4, 5 = Prime 5, 6 = Prime 6, 7 = Prime 7, 8=Prime 8, 9=All Primes, converter must be present
-----	----------------	---

Opcode: <3043H> **Command backup test converter configuration**

<1>	Prime To Test	1 = Prime 1, 2 = Prime 2, 3 = Prime 3, 4 = Prime 4, 5 = Prime 5, 6 = Prime 6, 7 = Prime 7, 8=Prime 8, 9=All Primes, converter must be present
-----	---------------	---

Opcode: <3044H> **Command set compensation control**

<1>	Compensation Control	0=Disable, 1=Enable
-----	----------------------	------------------------

Opcode: <3045H> **Command set converter compensation**

<2>	Prime Compensation	-50..50, one implied decimal point corresponds to -5.0 to 5.0 dB
<1>	Prime To Compensate	1 to 8, converter must be present

Opcode: <3046H> **Command set all converter compensations**

<2>	Prime 1 Compensation	-50..50, one implied decimal point corresponds to -5.0 to 5.0 dB
<2>	Prime 2 Compensation	-50..50, one implied decimal point corresponds to -5.0 to 5.0 dB
<2>	Prime 3 Compensation	-50..50, one implied decimal point corresponds to -5.0 to 5.0 dB
<2>	Prime 4 Compensation	-50..50, one implied decimal point corresponds to -5.0 to 5.0 dB
<2>	Prime 5 Compensation	-50..50, one implied decimal point corresponds to -5.0 to 5.0 dB
<2>	Prime 6 Compensation	-50..50, one implied decimal point corresponds to -5.0 to 5.0 dB
<2>	Prime 7 Compensation	-50..50, one implied decimal point corresponds to -5.0 to 5.0 dB
<2>	Prime 8 Compensation	-50..50, one implied decimal point corresponds to -5.0 to 5.0 dB

Opcode: <3047H> **Command set converter priority**

<1>	Prime Priority	0 to 8 (0 means not part of the backup pool)
<1>	Prime Number	1 = Prime 1, 2 = Prime 2, 3 = Prime 3, 4 = Prime 4, 5 = Prime 5, 6 = Prime 6, 7 = Prime 7, 8=Prime 8, converter must be present

Opcode: <3048H> **Command set all converter priorities**

<1>	Prime 1 Priority	0 to 8 (0 means not part of the backup pool)
<1>	Prime 2 Priority	0 to 8 (0 means not part of the backup pool)
<1>	Prime 3 Priority	0 to 8 (0 means not part of the backup pool)
<1>	Prime 4 Priority	0 to 8 (0 means not part of the backup pool)
<1>	Prime 5 Priority	0 to 8 (0 means not part of the backup pool)
<1>	Prime 6 Priority	0 to 8 (0 means not part of the backup pool)
<1>	Prime 7 Priority	0 to 8 (0 means not part of the backup pool)
<1>	Prime 8 Priority	0 to 8 (0 means not part of the backup pool)

 Opcode: <3048H> **Command set all converter priorities**

<1>	Prime 1 Priority	0 to 8 (0 means not part of the backup pool)
<1>	Prime 2 Priority	0 to 8 (0 means not part of the backup pool)
<1>	Prime 3 Priority	0 to 8 (0 means not part of the backup pool)
<1>	Prime 4 Priority	0 to 8 (0 means not part of the backup pool)
<1>	Prime 5 Priority	0 to 8 (0 means not part of the backup pool)
<1>	Prime 6 Priority	0 to 8 (0 means not part of the backup pool)
<1>	Prime 7 Priority	0 to 8 (0 means not part of the backup pool)
<1>	Prime 8 Priority	0 to 8 (0 means not part of the backup pool)

 Opcode: <3049H> **Command set switch alarm masks**

<1>	Major Alarm Mask	Bit 0 = Relay Fault Bit 1 = Backup Fault Bit 2 = No Backup Fault Bit 3 = Polling Fault 7 = Spares (0 = Mask, 1 = Allow)
<1>	Minor Alarm Mask	Bit 0 = Learned Fault Bit 1 = Backup Test Fault Configuration Changed Fault 7 = Spares (0 = Mask, 1 = Allow)

 Opcode: <304AH> **Command set switch fault delay**

<2>	Fault Delay	50..10000, value in msec
-----	-------------	--------------------------

Appendix C. SNMP MIB

CONVERTER-MIB DEFINITIONS ::= BEGIN

IMPORTS

enterprises
FROM RFC1155-SMI
MODULE-IDENTITY, OBJECT-TYPE
FROM SNMPv2-SMI;

converter MODULE-IDENTITY

LAST-UPDATED "200301081000Z"
ORGANIZATION "Comtech EF Data."
CONTACT-INFO

"Customer Service
Postal: Comtech EF Data
2114 W 7th St
Tempe, AZ 85281
USA

Tel: (480) 333-2200
Fax: (480) 333-2540

Email: xxx@comtechefdata.com"

DESCRIPTION

"Radyne converter MIB module."

REVISION "200109051000Z"

DESCRIPTION "Initial version of the Radyne Converter MIB module. This is a PRELIMINARY document whose contents are subject to change without prior notice. Converter MIB Object Identifiers description. The private enterprise number 2591 is a unique identifier assigned to Radyne by the Internet Assigned Numbers Authority (IANA). This number is used to uniquely define vendor specific information such as private MIBs."

::= { radyne 12 }

-- groups in Radyne specific MIB

radyne	OBJECT IDENTIFIER ::= { enterprises 2591 }
converterMIBObjects	OBJECT IDENTIFIER ::= { converter 1 }
radConverterNVStatus	OBJECT IDENTIFIER ::= { converterMIBObjects 1 }
radConverterStatus	OBJECT IDENTIFIER ::= { converterMIBObjects 2 }
radConverterSwitchNVStatus	OBJECT IDENTIFIER ::= { converterMIBObjects 3 }

```

radConverterSwitchStatus      OBJECT IDENTIFIER ::= { converterMIBObjects 4 }
radConverterCommonNVStatus   OBJECT IDENTIFIER ::= { converterMIBObjects 5 }
radConverterCommonStatus     OBJECT IDENTIFIER ::= { converterMIBObjects 6 }

radConverterMIBTraps         OBJECT IDENTIFIER ::= { converterMIBObjects 7 }

raConverterMIBConformance    OBJECT IDENTIFIER ::= { converter 2 }
raConverterGroups            OBJECT IDENTIFIER ::= { radConverterMIBConformance 1 }
radConverterAgentCapabilities OBJECT IDENTIFIER ::= { radConverterMIBConformance 2 }

```

```

-----
-- Textual Conventions

```

```

ControlType ::= TEXTUAL-CONVENTION

```

```

    STATUS      current
    DESCRIPTION  "Represents a boolean control value."
    SYNTAX      INTEGER { disable(1), enable(2) }

```

```

InversionType ::= TEXTUAL-CONVENTION

```

```

    STATUS      current
    DESCRIPTION  "Represents a boolean inversion value."
    SYNTAX      INTEGER { normal(1), inverted(2) }

```

```

AlarmByteType ::= TEXTUAL-CONVENTION

```

```

    STATUS      current
    DESCRIPTION  "Represents a one byte integer value. Limits are 0 to 255"
    SYNTAX      INTEGER (0..255)

```

```

PrimeStatusType ::= TEXTUAL-CONVENTION

```

```

    STATUS      current
    DESCRIPTION  "Represents a one byte integer value. Limits are 0 to 255
                  Bit0 = Prime1 status
                  Bit1 = Prime2 status
                  Bit2 = Prime3 status
                  Bit3 = Prime4 status
                  Bit4 = Prime5 status
                  Bit5 = Prime6 status
                  Bit6 = Prime7 status
                  Bit7 = Prime8 status "
    SYNTAX      INTEGER (0..255)

```

```

PrimeControlType ::= TEXTUAL-CONVENTION

```

```

    STATUS      current
    DESCRIPTION  "Represents a prime control setup. Limits are 1 to 9
                  1 = Prime1
                  2 = Prime2
                  3 = Prime3
                  4 = Prime4
                  5 = Prime5
                  6 = Prime6
                  7 = Prime7
                  8 = Prime8
                  9 = All Primes"
    SYNTAX      INTEGER (1..9)

```

```

-----
-- Converter non-volatile status information.

```

```

radConverterFrequency OBJECT-TYPE

```

```

    SYNTAX      INTEGER (50000000..90000000)
    MAX-ACCESS  read-write
    STATUS      current
    DESCRIPTION  "Selects RF input frequency in 125 KHz steps."

```

```

3.62 GHz to 4.20 GHz SFC4200 C-Band Down Converter
5.845 GHz to 6.425 GHz SFC6400 C-Band Up Converter
10.95 GHz to 12.75 GHz SFC 1275 Ku-Band Down Converter
14.00 GHz to 14.50 GHz SFC 1450 Ku-Band Up Converter"
 ::= { radConverterNVStatus 1 }

radConverterChannelGain OBJECT-TYPE
    SYNTAX      INTEGER (-200..300)
    MAX-ACCESS  read-write
    STATUS      current
    DESCRIPTION
        "Sets the Channel Gain in 0.1dB steps. -20.0 dB to 30.0 dB with an
        implied decimal point. "
 ::= { radConverterNVStatus 2 }

radConverterCurrentChannel OBJECT-TYPE
    SYNTAX      INTEGER (1..30)
    MAX-ACCESS  read-write
    STATUS      current
    DESCRIPTION
        "Channel number, 1 through 30. Selects the current channel of the unit.
        Each channel allows entering of an independent set of parameters (Frequency,
        Gain, etc.). For example, Channel 1 Frequency might be set to 3.8GHz and
        Channel 2 could be set to 4.0GHz. Any other parameters could be different
        as well. The advantage is that a completely different setup can be arrived
        at by merely changing the Channel number."
 ::= { radConverterNVStatus 3 }

radConverterCarrierControl OBJECT-TYPE
    SYNTAX      INTEGER {
                    off(1),
                    on(2)
                }
    MAX-ACCESS  read-write
    STATUS      current
    DESCRIPTION
        "Turns carrier off and on."
 ::= { radConverterNVStatus 4 }

radConverterMajorAlarmMask OBJECT-TYPE
    SYNTAX      AlarmByteType
    MAX-ACCESS  read-write
    STATUS      current
    DESCRIPTION
        "Major Alarm mask:
        Bit 0 = LO Fault
        Bit 1 = Signal Fault
        Bit 2-7 = Spares
        0 = Mask, 1 = Allow"
 ::= { radConverterNVStatus 5 }

radConverterMinorAlarmMask OBJECT-TYPE
    SYNTAX      AlarmByteType
    MAX-ACCESS  read-write
    STATUS      current
    DESCRIPTION
        "Minor Alarm mask:
        Bit 0 = RF Dtect Fault
        Bit 1 = IF Dtect Fault
        Bit 2-7 = Spares
        0 = Mask, 1 = Allow"
 ::= { radConverterNVStatus 6 }

-----
-----

```

-- Converter status information.

```
radConverterCarrierStatus OBJECT-TYPE
    SYNTAX      INTEGER {
                    off(1),
                    on(2)
                }
    MAX-ACCESS  read-only
    STATUS      current
    DESCRIPTION
        "Shows status of the carrier, on or off"
    ::= { radConverterStatus 1 }
```

```
radConverterSystemStatus OBJECT-TYPE
    SYNTAX      INTEGER {
                    standby(1),
                    online(2),
                    faulted(3),
                    setup(4)
                }
    MAX-ACCESS  read-only
    STATUS      current
    DESCRIPTION
        "Shows operating status of the converter"
    ::= { radConverterStatus 2 }
```

```
radConverterSwitchPresentStatus OBJECT-TYPE
    SYNTAX      INTEGER {
                    not_present(1),
                    present(2)
                }
    MAX-ACCESS  read-only
    STATUS      current
    DESCRIPTION
        "Shows switch status"
    ::= { radConverterStatus 3 }
```

```
radConverterConfiguration OBJECT-TYPE
    SYNTAX      INTEGER {
                    single_converter(1),
                    primary_1f1_converter(2),
                    backup_1f1_converter(3),
                    primary_1fn_converter(4),
                    backup_1fn_converter(5)
                }
    MAX-ACCESS  read-only
    STATUS      current
    DESCRIPTION
        "Shows converter configuration"
    ::= { radConverterStatus 4 }
```

```
radConverterType OBJECT-TYPE
    SYNTAX      INTEGER {
                    down(1),
                    up(2)
                }
    MAX-ACCESS  read-only
    STATUS      current
    DESCRIPTION
        "Shows converter type"
    ::= { radConverterStatus 5 }
```

```
radConverterBand OBJECT-TYPE
    SYNTAX      INTEGER {
                    c_band(1),
                    ku_band(2)
                }
```

```

    }
    MAX-ACCESS      read-only
    STATUS          current
    DESCRIPTION
        "Shows converter band"
    ::= { radConverterStatus 6 }

radConverterFrequencyType OBJECT-TYPE
    SYNTAX          INTEGER {
                        freq_70mhz(1),
                        freq_140mhz(2)
                    }
    MAX-ACCESS      read-only
    STATUS          current
    DESCRIPTION
        "Shows converter frequency type"
    ::= { radConverterStatus 7 }

radConverterReferenceType OBJECT-TYPE
    SYNTAX          INTEGER {
                        internal(1),
                        external(2)
                    }
    MAX-ACCESS      read-only
    STATUS          current
    DESCRIPTION
        "Shows converter reference type"
    ::= { radConverterStatus 8 }

radConverterMajorAlarmStatus OBJECT-TYPE
    SYNTAX          AlarmByteType
    MAX-ACCESS      read-only
    STATUS          current
    DESCRIPTION
        "A bit field. On startup, the agent initializes this
        to the value '00000000'B
        Bit 0 = LO Fault
        Bit 1 = Signal Fault
        Bit 2-7 = Spares
        0 = Pass, 1 = Fail"
    ::= { radConverterStatus 9 }

radConverterMinorAlarmStatus OBJECT-TYPE
    SYNTAX          AlarmByteType
    MAX-ACCESS      read-only
    STATUS          current
    DESCRIPTION
        "A bit field. On startup, the agent initializes this to
        the value '00000000'B
        Bit 0 = RF Dtect Fault
        Bit 1 = IF Dtect Fault
        Bit 2-7 = Spares
        0 = Pass, 1 = Fail"
    ::= { radConverterStatus 10 }

radConverterLatchedMajorAlarmStatus OBJECT-TYPE
    SYNTAX          AlarmByteType
    MAX-ACCESS      read-only
    STATUS          current
    DESCRIPTION
        "A bit field. On startup, the agent initializes this
        to the value '00000000'B.
        Bit 0 = LO Fault
        Bit 1 = Signal Fault
        Bit 2-7 = Spares
        0 = Pass, 1 = Fail"

```

```

 ::= { radConverterStatus 11 }

radConverterLatchedMinorAlarmStatus OBJECT-TYPE
    SYNTAX      AlarmByteType
    MAX-ACCESS  read-only
    STATUS      current
    DESCRIPTION
        "A bit field. On startup, the agent initializes this to
        the value '00000000'B.
        Bit 0 = RF Dect Fault
        Bit 1 = IF Dect Fault
        Bit 2-7 = Spares
        0 = Pass, 1 = Fail"
 ::= { radConverterStatus 12 }

radConverterICCAccess OBJECT-TYPE
    SYNTAX      INTEGER (1..255)
    MAX-ACCESS  read-only
    STATUS      current
    DESCRIPTION
        " "
 ::= { radConverterStatus 13 }

radConverterICCType OBJECT-TYPE
    SYNTAX      INTEGER (0..255)
    MAX-ACCESS  read-only
    STATUS      current
    DESCRIPTION
        "A bit field that shows converter ICC type. On startup, the agent
        initializes this to the value '00000000'B.
        Bit 0-3 = Band
            Down-Band: 0 through 5
                0=Normal C-Band, 1=Extended C-Band, 2=Normal Ku-Band,
                3=Normal American Ku-Band, 4=India High C-Band, 5=European
Ku-Band
            Up-Band: 0 through 4
                0=Normal C-Band, 1=Extended C-Band, 2=Normal Ku-Band,
                3=Normal Ku-Band, 4=India High C-Band
        Bit 4-5 = Spare          Not Used
        Bit 6 = Normal_Custom   0=Normal, 1=Custom
        Bit 7 = Down_Up         0=Down, 1=Up"
 ::= { radConverterStatus 14 }

-----
-----
-- Converter Switch non-volatile status information.

radConverterSwitchBackupMode OBJECT-TYPE
    SYNTAX      INTEGER {
        manual(1),
        auto_nonrevertive(2),
        auto_revertive(3)
    }
    MAX-ACCESS  read-write
    STATUS      current
    DESCRIPTION
        "Selects MANUAL or AUTOMATIC backup modes.
        Manual: A Prime Converter can be backed up through manual control only.
        Auto-Nonrevertive: A Prime Converter will be backed up if it fails.
        It will remain backed up until it is manually unbacked.
        Auto-Revertive: A Prime Converter will be backed up if it fails.
        If a second Converter of a higher priority (see 7. below) fails, the
        Switch will unback the first and backup the second Converter. Also,
        if the first Converter recovers after it has been backed up (i.e., no
        longer has a fault), the Switch will unback it and place it online again."

```



```

 ::= { radConverterSwitchNVStatus 1 }

radConverterSwitchLearn OBJECT-TYPE
    SYNTAX      PrimeControlType
    MAX-ACCESS  read-write
    STATUS      current
    DESCRIPTION
        "Learn Prime converter or learn All. Causes the Backup unit to 'Learn'
        all the settings of the selected Primes. The Backup can only backup a
        Prime that it has learned."
 ::= { radConverterSwitchNVStatus 2 }

radConverterSwitchBackupTest OBJECT-TYPE
    SYNTAX      PrimeControlType
    MAX-ACCESS  read-write
    STATUS      current
    DESCRIPTION
        "Checks if Prime can be backed up."
 ::= { radConverterSwitchNVStatus 3 }

radConverterSwitchForceBackup OBJECT-TYPE
    SYNTAX      INTEGER (0..8)
    MAX-ACCESS  read-write
    STATUS      current
    DESCRIPTION
        "Force a manual backup (select 1..8), or unback of a Prime (select 0).
        When in Manual Backup Mode, this selection will force the selected Prime
        to be backed up. Unback will release any Prime that is currently backed
        up."
 ::= { radConverterSwitchNVStatus 4 }

radConverterSwitchPriority OBJECT-TYPE
    SYNTAX      INTEGER (0..8)
    MAX-ACCESS  read-write
    STATUS      current
    DESCRIPTION
        "Prime converter priority. Sets the switching priority of a Prime unit.
        If more than one unit fails at the same time, the higher priority unit
        will be backed up. Also, if one unit is currently backed up and a second
        unit with a higher priority fails, the first unit will be unbacked and
        the second unit will be backed up (but only if Backup Mode is
        Auto-Revertive, see 1. above). The priority is set as follows.
        0 = No priority (the Switch will ignore the Downconverter).
        1 = Highest priority.
        8 = Lowest priority."
 ::= { radConverterSwitchNVStatus 5 }

radConverterSwitchCompensationControl OBJECT-TYPE
    SYNTAX      INTEGER {
                    disable(1),
                    enable(2)
                }
    MAX-ACCESS  read-write
    STATUS      current
    DESCRIPTION
        "Controls the Prime converter compensation, ENABLE/DISABLE."
 ::= { radConverterSwitchNVStatus 6 }

radConverterSwitchCompensation OBJECT-TYPE
    SYNTAX      INTEGER (-50..+50)
    MAX-ACCESS  read-write
    STATUS      current
    DESCRIPTION
        "Prime converter compensation of -5.0 dB to +5.0 dB (Implied decimal point).
        Offsets the gain of the Backup unit to account for variations in loss
        through the system."

```

This allows the user to ensure that the signal path of a particular Prime Converter maintains the same output power when backed up."

::= { radConverterSwitchNVStatus 7 }

radConverterSwitchFaultDelay OBJECT-TYPE

SYNTAX INTEGER (50..10000)

MAX-ACCESS read-write

STATUS current

DESCRIPTION

"Sets the delay between the time a Fault occurs in a Prime unit and the time it is acknowledged by the Backup. This only used in automatic backup modes."

::= { radConverterSwitchNVStatus 8 }

radConverterSwitchNoFaultDelay OBJECT-TYPE

SYNTAX INTEGER (50..10000)

MAX-ACCESS read-write

STATUS current

DESCRIPTION

"Sets the delay between the time a Fault goes away in a Prime unit and the time it is acknowledged as gone by the Backup. This only used in automatic backup modes. Not yet implemented."

::= { radConverterSwitchNVStatus 9 }

radConverterSwitchMajorAlarmMask OBJECT-TYPE

SYNTAX AlarmByteType

MAX-ACCESS read-write

STATUS current

DESCRIPTION

"Major Alarm mask:
Bit 0 = RelayFault
Bit 1 = Backup Fault
Bit 2 = NoBackup
Bit 3 = PollingFault
Bit 4-7 = Spares
0 = Mask, 1 = Allow"

::= { radConverterSwitchNVStatus 10 }

radConverterSwitchMinorAlarmMask OBJECT-TYPE

SYNTAX AlarmByteType

MAX-ACCESS read-write

STATUS current

DESCRIPTION

"Minor Alarm mask:
Bit 0 = LearnedFault
Bit 1 = BackupTestFault
Bit 2 = ConfigChangedFault
Bit 3-7 = Spares
0 = Mask, 1 = Allow"

::= { radConverterSwitchNVStatus 11 }

-- Converter Switch status information.

radConverterSwitchMajorAlarmStatus OBJECT-TYPE

SYNTAX AlarmByteType

MAX-ACCESS read-only

STATUS current

DESCRIPTION

"A bit field. On startup, the agent initializes this to the value '00000000'B.
Bit 0 = RelayFault
Bit 1 = Backup Fault
Bit 2 = NoBackup
Bit 3 = PollingFault"

```

                                Bit 4-7 = Spares
                                0 = Pass, 1 = Fail"
 ::= { radConverterSwitchStatus 1 }

radConverterSwitchMinorAlarmStatus OBJECT-TYPE
    SYNTAX          AlarmByteType
    MAX-ACCESS      read-only
    STATUS          current
    DESCRIPTION     "A bit field. On startup, the agent initializes this to
                    the value '00000000'B.
                    Bit 0 = LearnedFault
                    Bit 1 = BackupTestFault
                    Bit 2 = ConfigChangedFault
                    Bit 3-7 = Spares
                    0 = Pass, 1 = Fail"
 ::= { radConverterSwitchStatus 2 }

radConverterSwitchLatchedMajorAlarmStatus OBJECT-TYPE
    SYNTAX          AlarmByteType
    MAX-ACCESS      read-only
    STATUS          current
    DESCRIPTION     "A bit field. On startup, the agent initializes this
                    to the value '00000000'B.
                    Bit 0 = RelayFault
                    Bit 1 = Backup Fault
                    Bit 2 = NoBackup
                    Bit 3 = PollingFault
                    Bit 4-7 = Spares
                    0 = Pass, 1 = Fail"
 ::= { radConverterSwitchStatus 3 }

radConverterSwitchLatchedMinorAlarmStatus OBJECT-TYPE
    SYNTAX          AlarmByteType
    MAX-ACCESS      read-only
    STATUS          current
    DESCRIPTION     "A bit field. On startup, the agent initializes this to
                    the value '00000000'B.
                    Bit 0 = LearnedFault
                    Bit 1 = BackupTestFault
                    Bit 2 = ConfigChangedFault
                    Bit 3-7 = Spares
                    0 = Pass, 1 = Fail"
 ::= { radConverterSwitchStatus 4 }

radConverterSwitchFaultStatus OBJECT-TYPE
    SYNTAX          PrimeStatusType
    MAX-ACCESS      read-only
    STATUS          current
    DESCRIPTION     "Prime converter fault status:
                    Bit 0 = Prime 1
                    Bit 1 = Prime 2
                    Bit 2 = Prime 3
                    Bit 3 = Prime 4
                    Bit 4 = Prime 5
                    Bit 5 = Prime 6
                    Bit 6 = Prime 7
                    Bit 7 = Prime 8
                    0 = No Fault, 1 = Fault"
 ::= { radConverterSwitchStatus 5 }

radConverterSwitchRelayStatus OBJECT-TYPE
    SYNTAX          PrimeStatusType

```

```

MAX-ACCESS      read-only
STATUS          current
DESCRIPTION     "Prime converter relay status:
                Bit 0 = Prime 1
                Bit 1 = Prime 2
                Bit 2 = Prime 3
                Bit 3 = Prime 4
                Bit 4 = Prime 5
                Bit 5 = Prime 6
                Bit 6 = Prime 7
                Bit 7 = Prime 8
                0 = Off, 1 = On (Fault Condition)"
 ::= { radConverterSwitchStatus 6 }

radConverterSwitchConfigChangedStatus OBJECT-TYPE
SYNTAX          PrimeStatusType
MAX-ACCESS      read-only
STATUS          current
DESCRIPTION     "Prime converter configuration status:
                Bit 0 = Prime 1
                Bit 1 = Prime 2
                Bit 2 = Prime 3
                Bit 3 = Prime 4
                Bit 4 = Prime 5
                Bit 5 = Prime 6
                Bit 6 = Prime 7
                Bit 7 = Prime 8
                0 = No change, 1 = Changed"
 ::= { radConverterSwitchStatus 7 }

radConverterSwitchLearnStatus OBJECT-TYPE
SYNTAX          PrimeStatusType
MAX-ACCESS      read-only
STATUS          current
DESCRIPTION     "Prime converter learn status:
                Bit 0 = Prime 1
                Bit 1 = Prime 2
                Bit 2 = Prime 3
                Bit 3 = Prime 4
                Bit 4 = Prime 5
                Bit 5 = Prime 6
                Bit 6 = Prime 7
                Bit 7 = Prime 8
                0 = Not Learned, 1 = Learned"
 ::= { radConverterSwitchStatus 8 }

radConverterSwitchBackupTestStatus OBJECT-TYPE
SYNTAX          PrimeStatusType
MAX-ACCESS      read-only
STATUS          current
DESCRIPTION     "Prime converter backup test status:
                Bit 0 = Prime 1
                Bit 1 = Prime 2
                Bit 2 = Prime 3
                Bit 3 = Prime 4
                Bit 4 = Prime 5
                Bit 5 = Prime 6
                Bit 6 = Prime 7
                Bit 7 = Prime 8
                0 = Fail, 1 = Pass"
 ::= { radConverterSwitchStatus 9 }

```

radConverterSwitchPowerSenseStatus OBJECT-TYPE

SYNTAX PrimeStatusType
 MAX-ACCESS read-only
 STATUS current
 DESCRIPTION

"Prime converter power sense status:
 Bit 0 = Prime 1
 Bit 1 = Prime 2
 Bit 2 = Prime 3
 Bit 3 = Prime 4
 Bit 4 = Prime 5
 Bit 5 = Prime 6
 Bit 6 = Prime 7
 Bit 7 = Prime 8
 0 = No Power Present, 1 = Power Present"

::= { radConverterSwitchStatus 10 }

radConverterSwitchBackedupPrime OBJECT-TYPE

SYNTAX INTEGER (0..8)
 MAX-ACCESS read-only
 STATUS current
 DESCRIPTION

"Shows the currently backed up prime. 0 means no converters are currently backed up."

::= { radConverterSwitchStatus 11 }

radConverterSwitchHotStandbyPrime OBJECT-TYPE

SYNTAX INTEGER (0..8)
 MAX-ACCESS read-only
 STATUS current
 DESCRIPTION

"Shows the current prime converter in hot standby. 0 means no converter is currently in hot standby. This is valid only in automatic backup modes."

::= { radConverterSwitchStatus 12 }

 -- Converter common non-volatile status information.

radConverterCommonControlMode OBJECT-TYPE

SYNTAX INTEGER {
 front_panel(1),
 terminal(2),
 remote(3),
 ethernet(4),
 }
 MAX-ACCESS read-write
 STATUS current
 DESCRIPTION

""

::= { radConverterCommonNVStatus 1 }

radConverterCommonTerminalBaudRate OBJECT-TYPE

SYNTAX INTEGER {
 baud_2400(1),
 baud_9600(2),
 baud_19200(3),
 }
 MAX-ACCESS read-write
 STATUS current
 DESCRIPTION

"Selects terminal baud rate."

::= { radConverterCommonNVStatus 2 }

radConverterCommonTerminalEmulation OBJECT-TYPE

SYNTAX INTEGER {

```

        vt100(1),
        wyse50(2),
        addsvp(3)
    }
MAX-ACCESS      read-write
STATUS          current
DESCRIPTION     "Selects terminal emulation."
 ::= { radConverterCommonNVStatus 3 }

radConverterCommonTerminalEchoMode OBJECT-TYPE
SYNTAX          INTEGER {
                on(1),
                off(2)
            }
MAX-ACCESS      read-write
STATUS          current
DESCRIPTION     "Selects terminal echo mode. Not currently in use."
 ::= { radConverterCommonNVStatus 4 }

radConverterCommonRemoteProtocol OBJECT-TYPE
SYNTAX          INTEGER {
                ascii(1),
                rllp(2)
            }
MAX-ACCESS      read-write
STATUS          current
DESCRIPTION     "Selects remote port protocol."
 ::= { radConverterCommonNVStatus 5 }

radConverterCommonRemoteAddress OBJECT-TYPE
SYNTAX          INTEGER (1..255)
MAX-ACCESS      read-write
STATUS          current
DESCRIPTION     "Remote port address, 1 through 255."
 ::= { radConverterCommonNVStatus 6 }

radConverterCommonRemoteBaudRate OBJECT-TYPE
SYNTAX          INTEGER {
                baud_2400(1),
                baud_9600(2),
                baud_19200(3)
            }
MAX-ACCESS      read-write
STATUS          current
DESCRIPTION     "Selects remote port Baud Rate."
 ::= { radConverterCommonNVStatus 7 }

radConverterCommonRemoteLineControl OBJECT-TYPE
SYNTAX          INTEGER {
                rs232(1),
                rs485(2)
            }
MAX-ACCESS      read-write
STATUS          current
DESCRIPTION     "Selects RS232 or RS485."
 ::= { radConverterCommonNVStatus 8 }

radConverterCommonRemoteEchoMode OBJECT-TYPE
SYNTAX          INTEGER {
                on(1),

```

```

        off(2)
    }
MAX-ACCESS      read-write
STATUS          current
DESCRIPTION     "Sets Echo mode to on or off. Valid only for ASCII protocol remote
                serial interface"
 ::= { radConverterCommonNVStatus 9 }

radConverterCommonMajorAlarmMask OBJECT-TYPE
SYNTAX          AlarmByteType
MAX-ACCESS      read-write
STATUS          current
DESCRIPTION     "Major Alarm mask:
                Bit 0 = CPLD test fault
                Bit 1 = FPGA test fault
                Bit 2 = Eeprom test fault
                Bit 3-7 = Spares
                0 = Mask, 1 = Allow"
 ::= { radConverterCommonNVStatus 10 }

radConverterCommonMinorAlarmMask OBJECT-TYPE
SYNTAX          AlarmByteType
MAX-ACCESS      read-write
STATUS          current
DESCRIPTION     "Minor Alarm mask:
                Bit 0 = VCC1 fault
                Bit 1 = +9V fault
                Bit 2 = +15V fault
                Bit 3 = -15V fault
                Bit 4 = Reference activity fault
                Bit 5-7 = Spares
                0 = Mask, 1 = Allow"
 ::= { radConverterCommonNVStatus 11 }

-----
-----
-- Converter common status information.

radConverterCommonMajorAlarmStatus OBJECT-TYPE
SYNTAX          AlarmByteType
MAX-ACCESS      read-only
STATUS          current
DESCRIPTION     "A bit field. On startup, the agent initializes this
                to the value '00000000'B.
                Bit 0 = CPLD test fault
                Bit 1 = FPGA test fault
                Bit 2 = Eeprom test fault
                Bit 3-7 = Spares
                0 = Pass, 1 = Fail"
 ::= { radConverterCommonStatus 1 }

radConverterCommonMinorAlarmStatus OBJECT-TYPE
SYNTAX          AlarmByteType
MAX-ACCESS      read-only
STATUS          current
DESCRIPTION     "A bit field. On startup, the agent initializes this to
                the value '00000000'B.
                Bit 0 = VCC1 fault
                Bit 1 = +9V fault
                Bit 2 = +15V fault
                Bit 3 = -15V fault

```

```

                Bit 4 = Reference activity fault
                Bit 5-7 = Spares
                0 = Pass, 1 = Fail"
 ::= { radConverterCommonStatus 2 }

radConverterCommonLatchedMajorAlarmStatus OBJECT-TYPE
    SYNTAX      AlarmByteType
    MAX-ACCESS  read-only
    STATUS      current
    DESCRIPTION
        "A bit field. On startup, the agent initializes this
        to the value '00000000'B.
        Bit 0 = CPLD test fault
        Bit 1 = FPGA test fault
        Bit 2 = Eeprom test fault
        Bit 3-7 = Spares
        0 = Pass, 1 = Fail"
 ::= { radConverterCommonStatus 3 }

radConverterCommonLatchedMinorAlarmStatus OBJECT-TYPE
    SYNTAX      AlarmByteType
    MAX-ACCESS  read-only
    STATUS      current
    DESCRIPTION
        "A bit field. On startup, the agent initializes this to
        the value '00000000'B.
        Bit 0 = VCC1 fault
        Bit 1 = +9V fault
        Bit 2 = +15V fault
        Bit 3 = -15V fault
        Bit 4 = Reference activity fault
        Bit 5-7 = Spares
        0 = Pass, 1 = Fail"
 ::= { radConverterCommonStatus 4 }

radConverterCommonUserMinFrequency OBJECT-TYPE
    SYNTAX      INTEGER (3620000..14750000)
    MAX-ACCESS  read-only
    STATUS      current
    DESCRIPTION
        "User minimum frequency."
 ::= { radConverterCommonStatus 5 }

radConverterCommonUserMaxFrequency OBJECT-TYPE
    SYNTAX      INTEGER (3620000..14750000)
    MAX-ACCESS  read-only
    STATUS      current
    DESCRIPTION
        "User maximum frequency."
 ::= { radConverterCommonStatus 6 }

radConverterCommonSynthesizerType OBJECT-TYPE
    SYNTAX      INTEGER {
                mfs1191(1),
                mfs448(2),
                mfs459(3),
                mfs544(3),
                mfs881(4),
                mfs474(5),
                mfs4_47(6),
                mfs4_59(7)
                }
    MAX-ACCESS  read-write
    STATUS      current
    DESCRIPTION
        "Shows the currently used synthesizer:

```



```

MFS 1191:IF LO= 1.7 GHz, Low range = 11.91GHz, High range = 12.73 GHz
MFS 448:IF LO= 1.225 GHz, Low range = 4.48 GHz, High range = 5.355 GHz
MFS 459:IF LO= 1.1125 GHz, Low range = 4.5925 GHz, High range = 5.2425 GHz
MFS 544:IF LO= 1.1125 GHz, Low range = 5.4475 GHz, High range = 5.8675 GHz
MFS 881:IF LO= 2.0 GHz, Low range = 8.81 GHz, High range = 10.68 GHz
MFS 474:IF LO= 1.1125 GHz, Low range = 4.74 GHz, High range = 5.54 GHz
MFS 4_47:IF LO= 1.1125 GHz, Low range = 4.47 GHz, High range = 5.34 GHz
MFS 4_59:IF LO= 1.1125 GHz, Low range = 4.59 GHz, High range = 5.54 GHz"
 ::= { radConverterCommonStatus 7 }

radConverterCommonDCGainOffset OBJECT-TYPE
    SYNTAX      INTEGER (0..300)
    MAX-ACCESS  read-write
    STATUS      current
    DESCRIPTION
        "DC Gain offset. Implied decimal point, 0 through 30.0 dB"
 ::= { radConverterCommonStatus 8 }

radConverterCommonFirmwareVersion OBJECT-TYPE
    SYNTAX      INTEGER (10..255)
    MAX-ACCESS  read-write
    STATUS      current
    DESCRIPTION
        "Firmware version."
 ::= { radConverterCommonStatus 9 }

-----
-----

-- Converter Trap definitions.

-- Include Prefix for compatibility with SNMPv1 traps and procedures
-- employed by multi-lingual and proxy forwarding systems

radConverterMIBTrapPrefix OBJECT IDENTIFIER ::= { radConverterMIBTraps 0 }

radConverterColdStartTrap NOTIFICATION-TYPE
    STATUS      current
    DESCRIPTION "Unexpected restart."
 ::= { radConverterMIBTrapPrefix 1 }

radConverterAuthenticationFailureTrap NOTIFICATION-TYPE
    STATUS      current
    DESCRIPTION "Received a message that has failed authentication."
 ::= { radConverterMIBTrapPrefix 2 }

radConverterMajorAlarmTrap NOTIFICATION-TYPE
    STATUS      current
    DESCRIPTION "Major alarm trap."
 ::= { radConverterMIBTrapPrefix 3 }

radConverterMinorAlarmTrap NOTIFICATION-TYPE
    STATUS      current
    DESCRIPTION "Minor alarm trap."
 ::= { radConverterMIBTrapPrefix 4 }

radConverterCommonAlarmTrap NOTIFICATION-TYPE
    STATUS      current
    DESCRIPTION "Common alarm trap."
 ::= { radConverterMIBTrapPrefix 5 }

-----
-----

-- Converter MIB conformance

radConverterNVStatusGroup OBJECT-GROUP

```

```

OBJECTS
    {
        radConverterFrequency,
        radConverterChannelGain,
        radConverterCurrentChannel,
        radConverterCarrierControl,
        radConverterMajorAlarmMask,
        radConverterMinorAlarmMask
    }

STATUS      current
DESCRIPTION "Non-volatile status group."
 ::= { radConverterGroups 1 }

radConverterStatusGroup OBJECT-GROUP
OBJECTS
    {
        radConverterCarrierStatus,
        radConverterStatus,
        radConverterSwitchStatus,
        radConverteConfiguration,
        radConverterType,
        radConverterBand,
        radConverterFrequencyType,
        radConverterReferenceType,
        radConverterMajorAlarmStatus,
        radConverterMinorAlarmStatus,
        radConverterLatchedMajorAlarmStatus,
        radConverterLatchedMinorAlarmStatus,
        radConverterICCAAddress,
        radConverterICCType}

STATUS      current
DESCRIPTION "Volatile status group."
 ::= { radConverterGroups 2 }

radConverterSwitchNVStatusGroup OBJECT-GROUP
OBJECTS
    {
        radConverterSwitchBackupMode,
        radConverterSwitchLearn,
        radConverterSwitchBackupTest,
        radConverterSwitchForceBackup,
        radConverterSwitchPriority,
        radConverterSwitchCompensationControl,
        radConverterSwitchCompensation,
        radConverterSwitchFaultDelay,
        radConverterSwitchNoFaultDelay,
        radConverterSwitchMajorAlarmMask,
        radConverterSwitchMinorAlarmMask
    }

STATUS      current
DESCRIPTION "Switch non-volatile status group."
 ::= { radConverterGroups 3 }

radConverterSwitchStatusGroup OBJECT-GROUP
OBJECTS
    {
        radConverterSwitchMajorAlarmStatus,
        radConverterSwitchMinorAlarmStatus,
        radConverterSwitchLatchedMajorAlarmStatus,
        radConverterSwitchLatchedMinorAlarmStatus,
        radConverterSwitchFaultStatus,
        radConverterSwitchRelayStatus,
        radConverterSwitchConfigChangedStatus,
        radConverterSwitchLearnStatus,
        radConverterSwitchBackupTestStatus,
        radConverterSwitchPowerSenseStatus,
        radConverterSwitchBackedupPrime,
        radConverterSwitchHotStandbyPrime
    }

STATUS      current

```

```

DESCRIPTION    "Switch volatile status group."
 ::= { radConverterGroups 4 }

radConverterCommonNVStatusGroup OBJECT-GROUP
OBJECTS
    {
        radConverterCommonControlMode,
        radConverterCommonTerminalBaudRate,
        radConverterCommonTerminalEmulation,
        radConverterCommonTerminalEchoMode,
        radConverterCommonRemoteProtocol,
        radConverterCommonRemoteAddress,
        radConverterCommonRemoteBaudRate,
        radConverterCommonRemoteLineControl,
        radConverterCommonRemoteEchoMode,
        radConverterCommonMajorAlarmMask,
        radConverterCommonMinorAlarmMask
    }

STATUS        current
DESCRIPTION    "Common non-volatile status group."
 ::= { radConverterGroups 5 }

radConverterCommonStatusGroup OBJECT-GROUP
OBJECTS
    {
        radConverterCommonMajorAlarmStatus,
        radConverterCommonMinorAlarmStatus,
        radConverterCommonLatchedMajorAlarmStatus,
        radConverterCommonLatchedMinorAlarmStatus,
        radConverterCommonUserMinFrequency,
        radConverterCommonUserMaxFrequency,
        radConverterCommonSynthesizerType,
        radConverterCommonDCGainOffset,
        radConverterCommonFirmwareVersion
    }

STATUS        current
DESCRIPTION    "Common volatile status group."
 ::= { radConverterGroups 6 }

radConverterCommonNotificationsGroup NOTIFICATION-GROUP
NOTIFICATIONS {
    radConverterColdStartTrap,
    radConverterAuthenticationFailureTrap
}

STATUS        current
DESCRIPTION    "The two notifications which an SNMPv2 entity is required to
                implement."
 ::= { radConverterGroups 7 }

radConverterNotificationsGroup NOTIFICATION-GROUP
NOTIFICATIONS {
    radConverterMajorAlarmTrap,
    radConverterMinorAlarmTrap,
    radConverterCommonAlarmTrap
}

STATUS        current
DESCRIPTION    "Traps group."
 ::= { radConverterGroups 8 }

END

```

METRIC CONVERSIONS

Units of Length

Unit	Centimeter	Inch	Foot	Yard	Mile	Meter	Kilometer	Millimeter
1 centimeter	—	0.3937	0.03281	0.01094	6.214×10^{-6}	0.01	—	—
1 inch	2.540	—	0.08333	0.2778	1.578×10^{-5}	0.254	—	25.4
1 foot	30.480	12.0	—	0.3333	1.893×10^{-4}	0.3048	—	—
1 yard	91.44	36.0	3.0	—	5.679×10^{-4}	0.9144	—	—
1 meter	100.0	39.37	3.281	1.094	6.214×10^{-4}	—	—	—
1 mile	1.609×10^5	6.336×10^4	5.280×10^3	1.760×10^3	—	1.609×10^3	1.609	—
1 mm	—	0.03937	—	—	—	—	—	—
1 kilometer	—	—	—	—	0.621	—	—	—

Temperature Conversions

Temperature	° Fahrenheit	° Centigrade
Water freezes	32	0
Water boils	212	100
Absolute 0	-459.69	-273.16

Formulas
$^{\circ}\text{C} = (\text{F} - 32) * 0.555$
$^{\circ}\text{F} = (\text{C} * 1.8) + 32$

Units of Weight

Unit	Gram	Ounce Avoirdupois	Ounce Troy	Pound Avoirdupois	Pound Troy	Kilogram
1 gram	—	0.03527	0.03215	0.002205	0.002679	0.001
1 oz. avoird.	28.35	—	0.9115	0.0625	0.07595	0.02835
1 oz. troy	31.10	1.097	—	0.06857	0.08333	0.03110
1 lb. avoird.	453.6	16.0	14.58	—	1.215	0.4536
1 lb. Troy	373.2	13.17	12.0	0.8229	—	0.3732
1 kilogram	1.0×10^3	35.27	32.15	2.205	2.679	—



2114 WEST 7TH STREET TEMPE ARIZONA 85281 USA
480 • 333 • 2200 PHONE
480 • 333 • 2161 FAX