



KST-2000A/B

Ku-Band Satellite Transceiver Installation and Operation Manual

IMPORTANT NOTE: The information contained in this document supercedes all previously published information regarding this product. Product specifications are subject to change without prior notice.

Copyright © Comtech EF Data, 2007. All rights reserved. Printed in the USA. Comtech EF Data, 2114
West 7th Street, Tempe, Arizona 85281 USA, 480.333.2200, FAX: 480. 333.2161

Errata B for MN/KST2000AB.IOM Rev 9

Comtech EF Data Documentation Update

KST-2000A/B

Ku-Band Satellite Transceiver Installation and Operation Manual

IMPORTANT NOTE: The information contained in this document supercedes all previously published information regarding this product. Product specifications are subject to change without prior notice.

Part Number MNKST2000AB.IOM Revision 9

Subject: Update Section 1.1.4.2, remove CE Mark

Errata Part Number: ER-KST2000AB-EB9 (*Errata documents are not revised*)

PLM CO Number: C-0037043

Comments: See attached page(s). The new information will be included in the next released revision of the manual.

1.1.4.2 Other Features

Table 1-1. Features

| Feature | Description |
|---|--|
| Automatic Gain Control | The KST-2000A/B incorporates a closed loop control system that maintains the system's conversion gain (as measured from the IF input to the Ku-Band SSPA output) at the user's preset value despite the effects of temperature, aging, and cable loss. This feature is provided for use with Comtech EF Data SSPAs up to and including 40W. |
| Optional IF Input/Output of 70 or 140 MHz | Optional on ordering. |
| Redundancy Controller (Built-in) | Each KST-2000A/B converter unit contains the logic and switch drivers necessary for redundant configurations when used with the RJU-2000. |
| Selectable Serial Communication | There are several selectable serial communications: <ul style="list-style-type: none"> • EIA-232, EIA-485, or EIA-422 half-duplex • 300 to 19200 baud rate • 8N1, 7E2, and 7O2 (information bits, parity, stop bits) |
| Keypad/Display | An optional weatherproof keypad/display designed to control the KST-2000A/B configuration parameters and to monitor the fault system. |
| L-Band Received Power Monitor Output | An isolated output covers the 950 to 1700 MHz downlink bands. |
| Internal or External Reference | The KST-2000A/B's internal reference may be locked to an external standard at 5 or 10 MHz in order to reduce the system frequency errors to that set by the external reference; or the high-stability, electrically and mechanically tunable internal reference may be used. |
| External LED Indicators for Power On and Fault Indication | A GREEN LED indicates prime power ON when blinking and TX RF power ON when steady. A RED LED indicates a summary fault. |
| Power Factor Corrected Internal Power Supply | All KST-2000A/B power supplies have power factor corrected power supplies. |
| Flexible HPA options | The KST-2000A/B converter has built-in monitor and control circuitry and functions that operate with the following equipment: <ul style="list-style-type: none"> • KST-2000A/B product line SSPAs • Selected other SSPAs • Selected Traveling Wave Tube Amplifiers (TWTAs). <p>This flexibility enables adjusting the system's power output to meet application requirements by simply changing the HPA.</p> |
| Industry Standards Met | <ul style="list-style-type: none"> • IESS 308 and IESS 309 • FCC radiated emissions requirements <p>The KST-2000A/B system components are completely weatherproof units designed for the harsh environments of antenna-mounted systems. The system's operating parameters can be monitored and controlled using Windows™ based M&C software with a personal computer, a keypad/display built into the KST-2000A/B, or a hand held KP-10 as described in Chapter 3.</p> |

Note: For a redundant system, each KST-2000A/B must have a different serial address for the M&C through the RJU-2000 to work properly. Also, due to the parallel nature of the M&C interface **only EIA-485, and EIA-422, communications are supported through this device.**

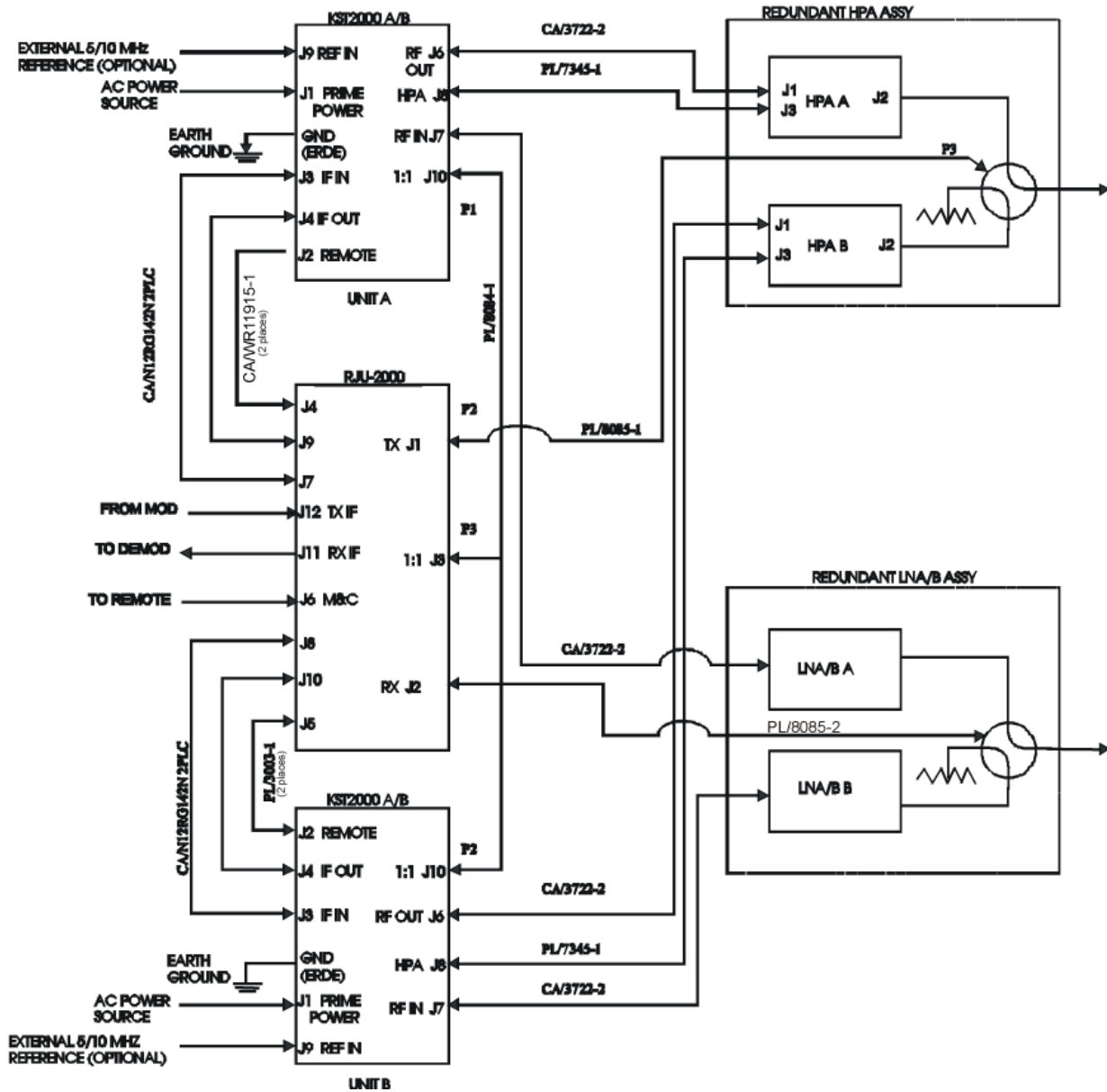

Figure 3-2. 1:1 Redundant System Block Diagram



Errata A

Comtech EF Data Documentation Update

Subject: Changes to 3.2 Initial Setup Redundant System

Date: January 24, 2008

Original Manual Part Number/Rev: MN/KST2000AB.IOM Rev 9

Errata Number: ER-CDM600.EA1

Agile Document ID ER-A-KST2000AB_REV9 **Agile CO Number** CO2362

Change Specifics:

This information will be incorporated into the next revision.

Updated pages 3-5 and 3-7 to reflect change in cable part number from **PL/3003-1** to **CA/WR11915-1**.

3.2 Initial Setup Redundant System

The following procedures are necessary to laboratory test a redundant KST-2000A/B system for the first time. Refer to the “Communications with Redundant Systems” section in the “M&C Software for Windows™” manual.

| Step | Procedure | Remarks |
|------|--|---|
| 1 | Ensure that the system is set up , except the HPA waveguide switch must be connected to a coupler termination or attenuator. and that the output of the waveguide switches have not been attached to the OMT. | |
| 2 | Remove the CA/WR11915-1 cable connection between J2, REMOTE, of the KST-2000A/B, unit B, and the RJU-2000. | Unit A determination is made by the PL/8084-1 cable P1 connection. |
| 3 | Apply AC power to KST-2000A/B, unit A. | |
| 4 | <p>Using a KP-10, or a PC equipped with a terminal, or Windows™ based M&C program, ensure communication with unit A via the RJU-2000 Remote connector J6. If communication is established use the address command (<add/AS_x{cr}) to set unit A to address 2.</p> <p>If communication is not established begin trouble-shooting. Ensure the proper cabling from the computer to the RJU. Ensure that the communication parameters of the computer match that of the KST-2000A. Ensure the proper mode of communication is being used (RS-485 or RS-422 see page 2-6 of this manual). If necessary connect directly to KST unit A, use RS-232 if the cabling is available. Use a terminal emulator and poll the KST with the command <*/AS_{cr}, this will globally poll the KST for it's address which is the most common problem.</p> <p>Delete If the communication parameters for the system are not known, the Windows□ based M&C system has a utility that will search all combinations of address, baud rate, and parity until communication is established with the system.</p> | <p><u>KST-2000A Default Communication Parameters:</u></p> <p>Address 1 Baud Rate 9600 Parity Even Stop bits 2 Data Length 7 bits</p> <ol style="list-style-type: none"> Using the KP-10 or terminal program, send a miscellaneous command such as EQUIPMENT TYPE (see Appendix B.8). Confirm a response is displayed. The Windows™ based status screen will turn from RED to GRAY when communications with the KST-2000A/B is established. |
| 5 | <ol style="list-style-type: none"> Repeat steps 2, 3 and 4 for Unit B. Ensure that the remote serial address differs from Unit A, typically set to address 3. | |
| 6 | Reconnect the M&C cable between J4 of the RJU-2000 and J2 of KST-2000A/B Unit A, and between J5 of the RJU-2000 and J2 of KST-2000A/B Unit B | |
| 7 | Ensure that serial communications through the RJU-2000, J6 connector, to each KST-2000A/B is still possible (RS-485 or RS-422 only). | The Windows™ based status screen will turn from RED to GRAY when communications with the KST-2000A/B is established. Use option/configuration to select redundancy. |

Customer Service

Contact the Comtech EF Data Customer Support Department for:

- Product support or training
- Reporting comments or suggestions concerning manuals
- Information on upgrading or returning a product

A Customer Support representative may be reached at:

Comtech EF Data
Attention: Customer Support Department
2114 West 7th Street
Tempe, Arizona 85281 USA

480.333.2200 (Main Comtech EF Data Number)
480.333.4357 (Customer Support Desk)
480.333.2161 FAX

To return a Comtech EF Data product (in-warranty and out-of-warranty) for repair or replacement:

- **Contact** the Comtech EF Data Customer Support Department. Be prepared to supply the Customer Support representative with the model number, serial number, and a description of the problem.
- **Request** a Return Material Authorization (RMA) number from the Comtech EF Data Customer Support representative.
- **Pack** the product in its original shipping carton/packaging to ensure that the product is not damaged during shipping.
- **Ship** the product back to Comtech EF Data. (Shipping charges should be prepaid.)

For Online Customer Support:

An RMA number request can be requested electronically by contacting the Customer Support Department through the online support page at www.comtechefdata.com/support.asp.

Click on the “RMA Request Form” hyperlink, then fill out the form completely before sending.

Click on “Return Material Authorization” for detailed instructions on our return procedures.

Send e-mail to the Customer Support Department at service@comtechefdata.com.

For information regarding this product’s warranty policy, refer to page xi.

Table of Contents

| | |
|---|-------------|
| Customer Service | ii |
| About this Manual | ix |
| Warnings and Cautions..... | ix |
| Installation Guidelines Regarding Power Line Quality | x |
| Warranty Policy | xi |
| CHAPTER 1. INTRODUCTION | 1-1 |
| 1.1 Description..... | 1-2 |
| 1.1.1 Receive Reject Filter | 1-2 |
| 1.1.2 Recommended Maintenance | 1-3 |
| 1.1.3 Areas of Operation:..... | 1-3 |
| 1.1.4 Features | 1-4 |
| 1.1.5 Single-Thread KST-2000A System | 1-6 |
| 1.1.6 Single-Thread KST-2000B System | 1-8 |
| 1.1.7 Redundant System | 1-9 |
| 1.2 Specifications | 1-10 |
| CHAPTER 2. INSTALLATION..... | 2-1 |
| 2.1. Single-Thread System Components..... | 2-1 |
| 2.2. Redundant System Components..... | 2-2 |
| 2.3. Description of Options | 2-3 |
| 2.4. Electrical Connections | 2-4 |
| 2.4.1. Converter Unit | 2-4 |
| 2.4.2. Data SSPAs | 2-13 |
| 2.4.3. LNA Connections | 2-20 |
| 2.4.4. LNB Connections..... | 2-20 |
| CHAPTER 3. OPERATION..... | 3-1 |
| 3.1 Initial Setup (Single-Thread System) | 3-1 |
| 3.1.1 Uplink Setup | 3-3 |
| 3.1.2 Downlink Setup | 3-4 |
| 3.2 Initial Setup Redundant System | 3-5 |

| | | |
|-------------------|--|-------------|
| 3.3 | Redundant Junction Unit Description | 3-8 |
| 3.3.1 | 3.3.1 RJU-2000 Description..... | 3-9 |
| 3.4 | Connector Descriptions | 3-10 |
| 3.4.1 | TX Switch Connector (J1) | 3-10 |
| 3.4.2 | RX Switch Connector (J2) | 3-10 |
| 3.4.3 | 1:1 Interface Connector (J3) | 3-11 |
| 3.4.4 | RFTA Remote Interface Connector (J4)..... | 3-12 |
| 3.4.5 | RFTB Remote Interface Connector (J5) | 3-13 |
| 3.4.6 | Interface M&C Connector (J6) | 3-14 |
| 3.4.7 | Other Connectors | 3-15 |
| 3.5 | Indicators Description | 3-15 |
| 3.6 | 1:1 Redundant KST-2000A/B System Operation..... | 3-16 |
| 3.7 | Reference Oscillator..... | 3-22 |
| 3.8 | Monitor and Control (M&C)..... | 3-23 |
| 3.8.1 | Up Converter Description | 3-25 |
| 3.9 | Ku- to L-Band Down Converter Description (KST-2000A)..... | 3-26 |
| 3.10 | L-Band to IF Down Converter Description (KST-2000A/B) | 3-27 |
| 3.11 | Automatic Gain Control (AGC) | 3-28 |
| 3.11.1 | Operation..... | 3-29 |
| 3.11.2 | Fault and Error Response..... | 3-30 |
| 3.11.3 | Manual Gain Operation..... | 3-31 |
| CHAPTER 4. | FAULT INDICATION AND ISOLATION..... | 4-1 |
| 4.1 | Fault Indication..... | 4-1 |
| 4.2 | Fault Isolation..... | 4-2 |
| 4.3 | Stored Faults..... | 4-2 |
| CHAPTER 5. | KEYPAD / DISPLAY | 1 |
| 5.1 | Keypad/Display Overview..... | 1 |
| 5.2 | Front Panel Keypad/Display | 2 |
| 5.2.1 | Front Panel Controls | 3 |
| 5.3 | The Menu Structure..... | 5 |
| 5.3.1 | Configuration | 6 |

| | | |
|---|--|-------------|
| 5.3.2 | Monitor | 9 |
| 5.3.3 | Faults..... | 10 |
| 5.3.4 | Utility..... | 13 |
| 5.3.5 | System | 14 |
| 5.3.6 | Redundancy..... | 16 |
| APPENDIX A. EQUIPMENT OUTLINE DRAWINGS | | A-1 |
| A.1 | 2 and 4 Watt SSPA Equipment Outline..... | A-2 |
| A.2 | 8 Watt SSPA Equipment Outline | A-3 |
| A.3 | 16 Watt SSPA Equipment Outline | A-4 |
| A.4 | 25/32/40 Watt SSPA Equipment Outline | A-5 |
| A.5 | Ku-Band LNA Equipment Outline..... | A-6 |
| A.6 | KST-2000A/B Converter Equipment Outline | A-7 |
| A.7 | Ku-Band LNB Equipment Outline..... | A-8 |
| APPENDIX B. TERMINAL MODE COMMANDS | | B-1 |
| B.1 | General..... | B-1 |
| B.2 | Message Structure..... | B-2 |
| B.2.1 | Start Character..... | B-2 |
| B.2.2 | Device Address | B-2 |
| B.2.3 | Command/Response..... | B-3 |
| B.2.3 | End Character..... | B-4 |
| B.3 | System Configuration Commands..... | B-4 |
| B.3.1 | Configuration Commands/Responses | B-5 |
| B.3.2 | System Configuration Commands | B-6 |
| B.3.3 | Reset Commands..... | B-8 |
| B.3.4 | Status Commands/Responses..... | B-8 |
| B.3.5 | Stored Faults..... | B-11 |
| B.3.6 | Miscellaneous | B-14 |
| B.4 | Backup Operations/Self-Contained Redundancy | B-15 |
| B.4.1 | External Fault Mode | B-16 |
| B.5 | Keypad/Display Related Commands | B-16 |
| APPENDIX C. SINGLE-THREAD EQUIPMENT MOUNTING | | C-1 |

| | | |
|---|--|-------------|
| C.1 | Tools Required | C-2 |
| C.2 | Converter Unit Installation | C-3 |
| C.2.1 | Spar Arm Mount | C-3 |
| C.2.2 | Pole Mount | C-6 |
| C.3 | SSPA Installation | C-10 |
| C.3.1 | Feed Mount Offset Antenna | C-10 |
| C.4 | LNA Installation | C-13 |
| C.4.1 | Feed Mount Offset Antenna | C-13 |
| C.5 | Cable Installation | C-14 |
| APPENDIX D. REDUNDANT EQUIPMENT MOUNTING | | D-1 |
| D.1 | Tools Required | D-2 |
| D.2 | 1:1 Converters Installation | D-3 |
| D.2.1 | Spar Arm Mount | D-3 |
| D.2.2 | Pole Mount | D-6 |
| D.3 | 1:1 SSPA Installation | D-10 |
| D.3.1 | Feed Mount Offset Antenna | D-10 |
| D.4 | 1:1 LNA Installation | D-11 |
| D.4.1 | Feed Mount Offset Antenna | D-11 |
| D.5 | Cable Installation | D-11 |
| APPENDIX E. FSK REMOTE CONTROL COMMANDS | | E-1 |
| E.1 | Introduction | E-1 |
| E.2 | Basic Protocol | E-2 |
| E.2.1 | Packet Structure | E-3 |
| E.2.2 | Start Of Packet | E-3 |
| E.2.3 | Address | E-3 |
| E.2.4 | Instruction Code | E-3 |
| E.2.5 | Instruction Code Qualifier | E-4 |
| E.2.6 | Message Arguments | E-6 |
| E.2.7 | End Of Packet | E-6 |
| E.3 | Commands and Query | E-6 |
| GLOSSARY | | g-1 |

INDEX **i-1**

Figures

FIGURE 1-1. KST-2000A/B CONVERTER UNIT AND 8 WATT SSPA 1-1
FIGURE 1-2. RECEIVE REJECT FILTER 1-2
FIGURE 1-3. SINGLE THREAD KST-2000A SYSTEM 1-6
FIGURE 1-4. SINGLE THREAD KST-2000B BLOCK DIAGRAM 1-8
FIGURE 1-5. REDUNDANT KST-2000A SYSTEM BLOCK DIAGRAM 1-9
FIGURE 2-1. I/O VIEW OF KST-2000A/B CONVERTER UNIT 2-4
FIGURE 2-2. PRIME POWER INPUT (J1)..... 2-5
FIGURE 2-3. SERIAL (EIA-232) ADAPTER CABLE WIRING DIAGRAM 2-7
FIGURE 2-4. 16WATT SSPA..... 2-14
FIGURE 2-5. I/O CONNECTORS FOR THE 16 WATT SSPA 2-15
FIGURE 2-6. OUTPUT CONNECTION FOR THE 16 WATT SSPA (WAVEGUIDE)..... 2-16
FIGURE 2-7. 25/32/40 WATT SSPA 2-17
FIGURE 2-8. I/O CONNECTORS FOR THE 25/32/40 WATT SSPA 2-18
FIGURE 2-9. OUTPUT CONNECTION FOR THE 25/32/40 WATT SSPA (WAVEGUIDE)..... 2-19
FIGURE 3-1. SINGLE-THREAD SYSTEM 3-2
FIGURE 3-2. 1:1 REDUNDANT SYSTEM BLOCK DIAGRAM..... 3-7
FIGURE 3-3. RJU-2000 FRONT PANEL 3-8
FIGURE 3-4. RJU-2000 BLOCK DIAGRAM..... 3-9
FIGURE 3-5. REDUNDANT KST-2000A/B SYSTEM SHOWING UNITS A AND B DESIGNATION
..... 3-17
FIGURE 3-6. REDUNDANT HPA ASSEMBLY 3-18
FIGURE 3-7. REDUNDANT LNA/B ASSEMBLY 3-19
FIGURE 3-8. REFERENCE OSCILLATOR 3-22
FIGURE 3-9. MONITOR AND CONTROL (M&C) BLOCK DIAGRAM 3-23
FIGURE 3-10. IF TO S-BAND CONVERTER MODULE BLOCK DIAGRAM..... 3-25
FIGURE 3-11. S TO KU-BAND UP CONVERTER MODULE..... 3-26
FIGURE 3-12. KU TO L-BAND DOWN CONVERTER MODULE BLOCK DIAGRAM..... 3-26
FIGURE 3-13. L-BAND TO IF DOWN CONVERTER BLOCK DIAGRAM 3-27
FIGURE 3-14. AGC OPERATING REGION..... 3-31
FIGURE 5-1. KST-2000A/B TERMINAL KEYPAD..... 5-2
FIGURE 5-2. KST-2000A/B SIGN ON MESSAGE..... 5-3
FIGURE 5-3. PRINCIPLE MENU TREES 5-4
FIGURE 5-4. SELECT MENU 5-5
FIGURE 5-5. CONFIGURATION MENU 5-6
FIGURE 5-6. MONITOR MENU 5-9
FIGURE 5-7. FAULTS MENU FIGURE 5-8. FAULTS SUB-LEVEL 5-10
FIGURE 5-9. UTILITY MENU 5-13
FIGURE 5-10. SYSTEM MENU 5-14
FIGURE 5-11. REDUNDANCY MENU 5-16
FIGURE A-1. 2 AND 4 WATT SSPA EQUIPMENT OUTLINE A-2
FIGURE A-2. 8 WATT SSPA EQUIPMENT OUTLINE..... A-3
FIGURE A-3. 16 WATT SSPA EQUIPMENT OUTLINE..... A-4
FIGURE A-4. 25/32/40 WATT SSPA EQUIPMENT OUTLINE A-5

FIGURE A-5. KU-BAND LNA EQUIPMENT OUTLINE A-6
 FIGURE A-6. KST-2000A/B CONVERTER EQUIPMENT OUTLINE A-7
 FIGURE A-7. KU-BAND LNB EQUIPMENT OUTLINE A-8
 FIGURE C-1. KST-2000A SINGLE THREAD SYSTEM INSTALLED ON SPAR ARM..... C-2
 FIGURE C-2. TYPICAL CONVERTER UNIT INSTALLATION ON SPAR C-5
 FIGURE C-3. KST-2000A CONVERTER WITH MOUNTING BRACKETS..... C-7
 FIGURE C-4. REAR VIEW OF CONVERTER INSTALLED ON ROUND POLE C-8
 FIGURE C-5. FRONT VIEW OF CONVERTER INSTALLED ON ROUND POLE..... C-9
 FIGURE C-6. INSTALLING THE SSPA C-11
 FIGURE C-7. SSPA INSTALLED..... C-12
 FIGURE D-1. 1:1 SYSTEM INSTALLED ON SPAR ARM D-2
 FIGURE D-2. CONVERTERS AND SSPAS ON SPAR ARM..... D-5
 FIGURE D-3. KST-2000A 1:1 CONVERTERS WITH MOUNTING BRACKETS D-7
 FIGURE D-4. REAR VIEW OF CONVERTERS INSTALLED ON POLE D-9
 FIGURE D-5. FRONT VIEW OF CONVERTERS INSTALLED ON POLE..... D-9

Tables

TABLE 1-1. FEATURES 1-5
 TABLE 1-2. CONVERTER UNIT SPECIFICATIONS 1-10
 TABLE 1-3. SYSTEM TRANSMIT CHARACTERISTICS (WITH SSPAS OF $\leq 40W$) 1-11
 TABLE 1-4. LNA CHARACTERISTICS 1-12
 TABLE 1-5. LNB CHARACTERISTICS 1-12
 TABLE 1-6. SSPA CHARACTERISTICS 1-13
 TABLE 2-1. DESCRIPTION OF OPTIONS..... 2-3
 TABLE 2-2. CONVERTER UNIT EXTERNAL CONNECTIONS 2-5
 TABLE 2-3. REMOTE M&C CONNECTOR (J2) PIN ASSIGNMENTS 2-6
 TABLE 2-4. HPA CONNECTOR (J8) PIN ASSIGNMENTS (CEFD SSPA) 2-10
 TABLE 2-5. HPA CONNECTOR (J8) PIN ASSIGNMENTS (NON-KST SPECIFIC SSPA)..... 2-10
 TABLE 2-6. HPA CONNECTOR (J8) PIN ASSIGNMENTS (TWTA CONNECTION)..... 2-11
 TABLE 2-7. 1:1 CONNECTOR (J10) PIN ASSIGNMENTS 2-12
 TABLE 2-8. FAN (J4) PIN ASSIGNMENTS 2-13
 TABLE 3-1. CONNECTOR J1 PINOUT DESCRIPTION 3-10
 TABLE 3-2. CONNECTOR J2 PINOUT DESCRIPTION 3-10
 TABLE 3-3. 1:1 INTERFACE CONNECTOR J3 PINOUT DESCRIPTION 3-11
 TABLE 3-4. RFTA REMOTE INTERFACE CONNECTOR J4 PINOUT DESCRIPTION..... 3-12
 TABLE 3-5. RFTB REMOTE INTERFACE CONNECTOR J5 PINOUT DESCRIPTION..... 3-13
 TABLE 3-6. INTERFACE M&C CONNECTOR J6 PINOUT DESCRIPTION 3-14
 TABLE 3-7. AGC FAULT AND ERROR RESPONSE 3-30
 TABLE 4-1. KST-2000A/B FAULT TREE 4-3

Preface

About this Manual

This manual provides installation and operation information for the Comtech EF Data Ku-Band Satellite Transceiver. This is a technical document intended for earth station engineers, technicians, and operators responsible for the operation and maintenance of the KST-2000A/B.

Trademarks

Product names mentioned in this manual may be trademarks or registered trademarks of their respective companies and are hereby acknowledged.

Warnings and Cautions



***WARNING** indicates a potentially hazardous situation that, if not avoided, could result in death or serious injury.*



***CAUTION** indicates a hazardous situation that, if not avoided, may result in minor or moderate injury. CAUTION may also be used to indicate other unsafe practices or risks of property damage.*



***IMPORTANT** indicates information critical for proper equipment function.*

Reporting Comments or Suggestions Concerning this Manual

Comments and suggestions regarding the content and design of this manual will be appreciated. To submit comments, please contact the Comtech EF Data Technical Publications Department.

Related Documents

- *Comtech EF Data KP-10 External Keypad Installation and Operation Manual*
- *Comtech EF Data Windows based Monitor and Control software for Comtech EFData Satellite Terminals Installation and Operation Manual, part number MN/M&CWIN.IOM.*

Installation Guidelines Regarding Power Line Quality

As a company with many years of experience selling and servicing equipment installed around the world, Comtech EF Data has become familiar with the varying quality of the AC power grid around the world. The following offers some installation guidelines that should help ensure a reliable installation.

- **Surge suppression:** High voltage surges can cause failure of the power supply. These surges are typically caused by circuit switching on the main AC power grid, erratic generator operation, and also by lightning strikes. While the transceiver does have built in surge suppression, if the unit will be installed in a location with questionable power grid quality, Comtech EF Data recommends installation of additional power conditioning/surge suppression at the power junction box.
- **Grounding:** The transceiver provides a grounding terminal. This is provided to allow the user to ground the transceiver to the antenna's grounding network. All components installed at the antenna shall be grounded to a common grounding point at the antenna.
- **Electrical welding:** If welding needs to take place at the antenna, disconnect all cables from the transceiver except for the ground wire. Cap all RF connections with terminations. This will prevent damage to the input/output circuitry of the transceiver.
- **Lightning:** Lightning strikes on or around the antenna will generate extremely high voltages on all cables connected to the transceiver. Depending on the severity of the strike, the transceivers internal surge protection combined with the recommended external suppression may protect the transceivers power supply. However, if the installation will be in an area with a high probability of lightning strikes, Comtech EF Data recommends the installation of surge suppression on the RF and IF cables. One source of these suppressors is PolyPhaser (www.polyphaser.com)

For further information, please contact Comtech EF Data.

Warranty Policy

Comtech EF Data products are warranted against defects in material and workmanship for a period of two years from the date of shipment. During the warranty period, Comtech EF Data will, at its option, repair or replace products that prove to be defective.

For equipment under warranty, the owner is responsible for freight to Comtech EF Data and all related customs, taxes, tariffs, insurance, etc. Comtech EF Data is responsible for the freight charges only for return of the equipment from the factory to the owner. Comtech EF Data will return the equipment by the same method (i.e., Air, Express, Surface) as the equipment was sent to Comtech EF Data.

All equipment returned for warranty repair must have a valid RMA number issued prior to return and be marked clearly on the return packaging. Comtech EF Data strongly recommends all equipment be returned in its original packaging.

Comtech EF Data Corporation's obligations under this warranty are limited to repair or replacement of failed parts, and the return shipment to the buyer of the repaired or replaced parts.

Limitations of Warranty

The warranty does not apply to any part of a product that has been installed, altered, repaired, or misused in any way that, in the opinion of Comtech EF Data Corporation, would affect the reliability or detracts from the performance of any part of the product, or is damaged as the result of use in a way or with equipment that had not been previously approved by Comtech EF Data Corporation.

The warranty does not apply to any product or parts thereof where the serial number or the serial number of any of its parts has been altered, defaced, or removed.

The warranty does not cover damage or loss incurred in transportation of the product.

The warranty does not cover replacement or repair necessitated by loss or damage from any cause beyond the control of Comtech EF Data Corporation, such as lightning or other natural and weather related events or wartime environments.

The warranty does not cover any labor involved in the removal and or reinstallation of warranted equipment or parts on site, or any labor required to diagnose the necessity for repair or replacement.

The warranty excludes any responsibility by Comtech EF Data Corporation for incidental or consequential damages arising from the use of the equipment or products, or for any inability to use them either separate from or in combination with any other equipment or products.

A fixed charge established for each product will be imposed for all equipment returned for warranty repair where Comtech EF Data Corporation cannot identify the cause of the reported failure.

Exclusive Remedies

Comtech EF Data Corporation's warranty, as stated is in lieu of all other warranties, expressed, implied, or statutory, including those of merchantability and fitness for a particular purpose. The buyer shall pass on to any purchaser, lessee, or other user of Comtech EF Data Corporation's products, the aforementioned warranty, and shall indemnify and hold harmless Comtech EF Data Corporation from any claims or liability of such purchaser, lessee, or user based upon allegations that the buyer, its agents, or employees have made additional warranties or representations as to product preference or use.

The remedies provided herein are the buyer's sole and exclusive remedies. Comtech EF Data shall not be liable for any direct, indirect, special, incidental, or consequential damages, whether based on contract, tort, or any other legal theory.

Chapter 1. INTRODUCTION

This chapter provides a description and the specifications for the KST-2000A/B satellite terminal system. The converter unit and 8 Watt SSPA are shown in Figure 1-1.



Figure 1-1. KST-2000A/B Converter Unit and 8 Watt SSPA

Various configurations of the KST-2000A/B Ku-Band satellite terminal system are available with both optional and standard equipment.

1.1 Description

The KST-2000A/B Ku-Band satellite terminal is a high-performance, full-featured transceiver designed for outdoor operation. The converter unit controls external **H**igh **P**ower **A**mplifiers (HPAs). **A**utomatic **G**ain **C**ontrol (AGC) from the converter input to the HPA output assures power output stability over varying conditions for up to 40W Comtech EF Data **S**olid-**S**tate **P**ower **A**mplifier (SSPAs).

Note: For TX only application, downlink functions and hardware are not supplied or available.

1.1.1 Receive Reject Filter

The KST-2000A/B is capable of operating over an uplink frequency of 13.75 to 14.5 GHz. Due to the proximity of the lower end of this band to the upper end of the Ku receive band, it is possible for the upconverter to radiate noise power in the upper range of the receive band.

If the transceiver Rx frequency is above 11.9 GHz, Comtech EF Data recommends installing the supplied Receive Reject Filter (Figure 1-2) on the output of the SSPA for single-thread systems and the output of the switch on redundant systems.

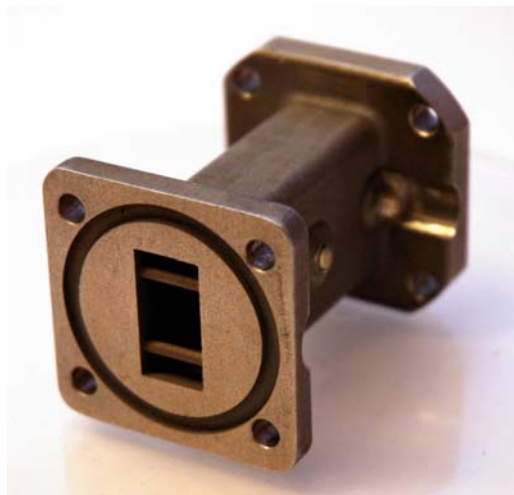

Figure 1-2. Receive Reject Filter

1.1.2 Recommended Maintenance

The fans utilized by the KST SSPAs are designed for long life even in a harsh environment. They are still mechanical devices subject to wear and may need replacement after several years. Industry environments, fan shroud removal facilitates clearing the heat sink of accumulated dust.

Once a year (or sooner depending on environmental conditions), the SSPA heat sink should be cleaned.

To perform this maintenance:

1. Disconnect power from the SSPA
2. Remove the fan shroud assembly
3. Using compressed air, blow through the SSPA heat sink to remove any foreign object accumulation that may be obstructing airflow.
4. Reinstall the supply and fan assembly.

No routine maintenance is required for the KST base unit.

1.1.3 Areas of Operation:

The areas of operation are as follows:

| | |
|---|--|
| Converter | Convection cooled up/down converter with an internal power supply and microprocessor-based Monitor and Control (M&C) . The converter contains a wide band block Ku- to L-Band down converter in the KST-2000A, or this function may be performed in an external Low Noise Block converter (LNB) in the KST-2000B. |
| HPA | Offered with various power output capabilities. |
| KST-2000A Only – Low Noise Amplifier (LNA) | LNAs with and without a Transmit Reject Filter (TRF) and various noise temperatures or noise figures are available. |
| KST-2000B Only – Low Noise Block (LNB) Assembly | LNAs with various frequency coverage are available. |
| FSK Remote Commands (Single-Thread Configuration only) | Modifications have been made to the KST-2000A firmware and hardware to permit monitor and control from the front panel of select Comtech EF Data Satellite Modems. Currently the CDM-550T and CDM-600 modems can monitor and control the KST-2000A. This control is transmitted via an FSK signal superimposed on the RX connection. |

1.1.4 Features

1.1.4.1 Full Ku-Band Transmit and Receive Coverage

KST-2000A Only

| | |
|---------------------------|------------------------------------|
| 13.75 to 14.5 GHz | Transmit range in 1 MHz |
| 14.00 to 14.5 GHz | Transmit range in 1 MHz (Optional) |
| 10.95 to 12.75 GHz | Receive range in 1 MHz steps |

KST-2000B Only

| | |
|---|--|
| 13.75 to 14.5 GHz | Transmit range in 1 MHz steps for HPAs of $\leq 40W$ |
| 14.00 to 14.5 GHz | Transmit range in 1 MHz steps for HPAs of $> 40W$ (Optional) |
| 10.95 to 11.70 GHz 11.70 to 12.20 GHz 12.25 to 12.75 GHz | LNB-Select: Receive range in 1 MHz steps |

1.1.4.2 Other Features

Table 1-1. Features

| Feature | Description |
|---|---|
| Automatic Gain Control | The KST-2000A/B incorporates a closed loop control system that maintains the system's conversion gain (as measured from the IF input to the Ku-Band SSPA output) at the user's preset value despite the effects of temperature, aging, and cable loss. This feature is provided for use with Comtech EF Data SSPAs up to and including 40W. |
| Optional IF Input/Output of 70 or 140 MHz | Optional on ordering. |
| Redundancy Controller (Built-in) | Each KST-2000A/B converter unit contains the logic and switch drivers necessary for redundant configurations when used with the RJU-2000. |
| Selectable Serial Communication | There are several selectable serial communications: <ul style="list-style-type: none"> • EIA-232, EIA-485, or EIA-422 half-duplex • 300 to 19200 baud rate • 8N1, 7E2, and 7O2 (information bits, parity, stop bits) |
| Keypad/Display | An optional weatherproof keypad/display designed to control the KST-2000A/B configuration parameters and to monitor the fault system. |
| L-Band Received Power Monitor Output | An isolated output covers the 950 to 1700 MHz downlink bands. |
| Internal or External Reference | The KST-2000A/B's internal reference may be locked to an external standard at 5 or 10 MHz in order to reduce the system frequency errors to that set by the external reference; or the high-stability, electrically and mechanically tunable internal reference may be used. |
| External LED Indicators for Power On and Fault Indication | A GREEN LED indicates prime power ON when blinking and TX RF power ON when steady. A RED LED indicates a summary fault. |
| Power Factor Corrected Internal Power Supply | All KST-2000A/B power supplies have power factor corrected power supplies and meet all CE Mark requirements. |
| Flexible HPA options | The KST-2000A/B converter has built-in monitor and control circuitry and functions that operate with the following equipment: <ul style="list-style-type: none"> • KST-2000A/B product line SSPAs • Selected other SSPAs • Selected Traveling Wave Tube Amplifiers (TWTAs). <p>This flexibility enables adjusting the system's power output to meet application requirements by simply changing the HPA.</p> |
| Industry Standards Met | <ul style="list-style-type: none"> • IESS 308 and IESS 309 • FCC radiated emissions requirements • CE Mark <p>The KST-2000A/B system components are completely weatherproof units designed for the harsh environments of antenna-mounted systems. The system's operating parameters can be monitored and controlled using Windows™ based M&C software with a personal computer, a keypad/display built into the KST-2000A/B, or a hand held KP-10 as described in Chapter 3.</p> |

1.1.5 Single-Thread KST-2000A System

A block diagram of a single-thread, KST-2000A system is shown in Figure 1-3.

Note: The modem, the remote M&C, OMT, and the antenna are not part of the KST-2000A system and are shown for reference only.

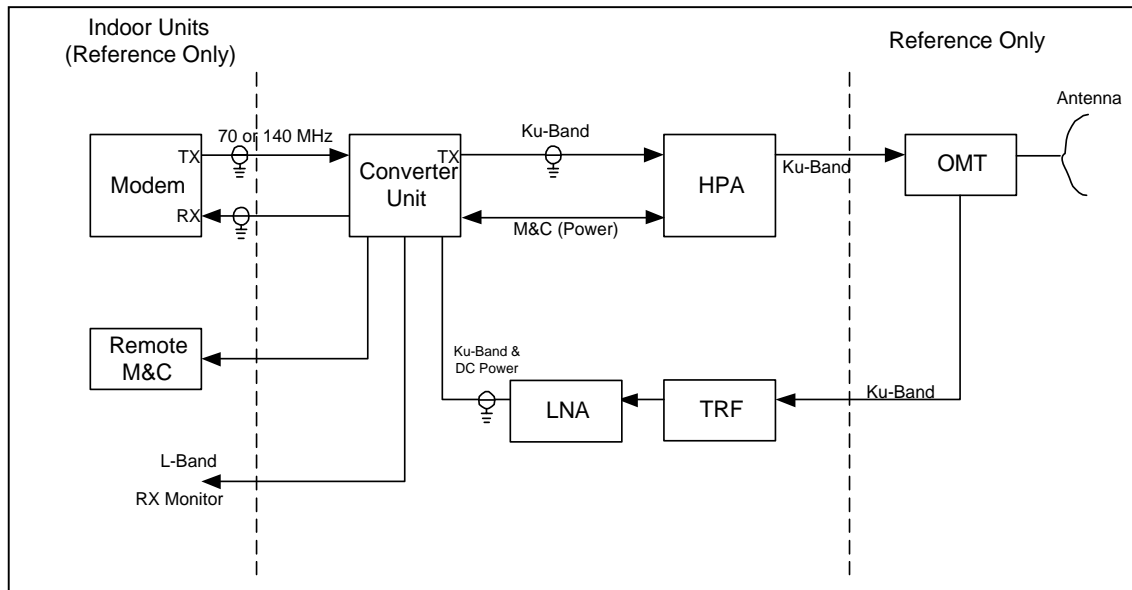

Figure 1-3. Single Thread KST-2000A System

The M&C remote control, whose operation is described in Chapter 3, is used to set the operating parameters of the KST-2000A/B system such as transmit and receive frequency, gain, etc.; and to monitor the operation of the system. Connection to the remote M&C is only required during setup and for interrogating the system health status.

Alternately, the keypad/display can be used to set the operating parameters of the KST-2000A/B and to query the system for faults. Connection to a remote terminal is not required for the keypad/display to function, as the keypad/display is totally independent of the remote control system.

In the transmit (Uplink) direction, the converter unit receives a $70 \text{ MHz} \pm 20 \text{ MHz}$ signal ($140 \text{ MHz} \pm 40 \text{ MHz}$ signal optional) at -25 to -45 dBm from a modem via a 50 or 75 Ω coaxial cable. The converter's input connector for this signal is a type N, female.

The converter unit performs a block conversion (non-inverted sense) first to S-Band, then to Ku-Band. The exact frequency output and power level are set by the user via the remote M&C or keypad/display. The converter output is coupled to an HPA via a coaxial cable with a 50 Ω , female, type N connector at the converter output.

The HPA receives the Ku-Band input from the converter and amplifies it to the user-selected level.

For KST-2000A/B SSPAs of ≤ 8 Watts, prime power is supplied by the converter via the M&C cable, while SSPAs > 8 Watts require a separate power source. The output power of the SSPA is set by the user via the remote M&C or keypad, and this output is connected to the feed of the antenna via WR-75 waveguide.

In the receive (Downlink) direction, the received Ku-Band signal from the antenna is offset in frequency from the transmitted signal allowing rejection of the transmitted signal by the Transmit Reject Filter (TRF). The exact receive frequency is set by the user via the remote M&C, or entered using the keypad (on keypad/display equipped transceivers). The received signal is amplified in an LNA whose output is coupled to the converter's input via a coaxial cable with type N connectors. This same cable is used to provide prime power (+15 VDC) to the LNA.

The converter unit performs a block down conversion (non-inverted sense) first to L-Band, then to 70 MHz (or 140 MHz if that option was ordered). An output is provided at L-Band (950 to 1700 MHz) to monitor the received signal. This is particularly useful during set up and fault finding.

1.1.6 Single-Thread KST-2000B System

A block diagram of the KST-2000B, single-thread Ku-Band system is shown in Figure 1-4. The operation of KST-2000B system is identical to the KST-2000A system described in section 1.1.3 except in the receive (downlink) portion.

With the KST-2000B system, a LNB replaces the LNA and the block down converter from Ku-Band to L-Band in the converter unit. In this configuration, the LNB sets the received frequency range. The LNB to converter cable carries the LNB's L-Band output, LNB prime power (+15 VDC) and a 10 MHz reference signal from the converter to the LNB.

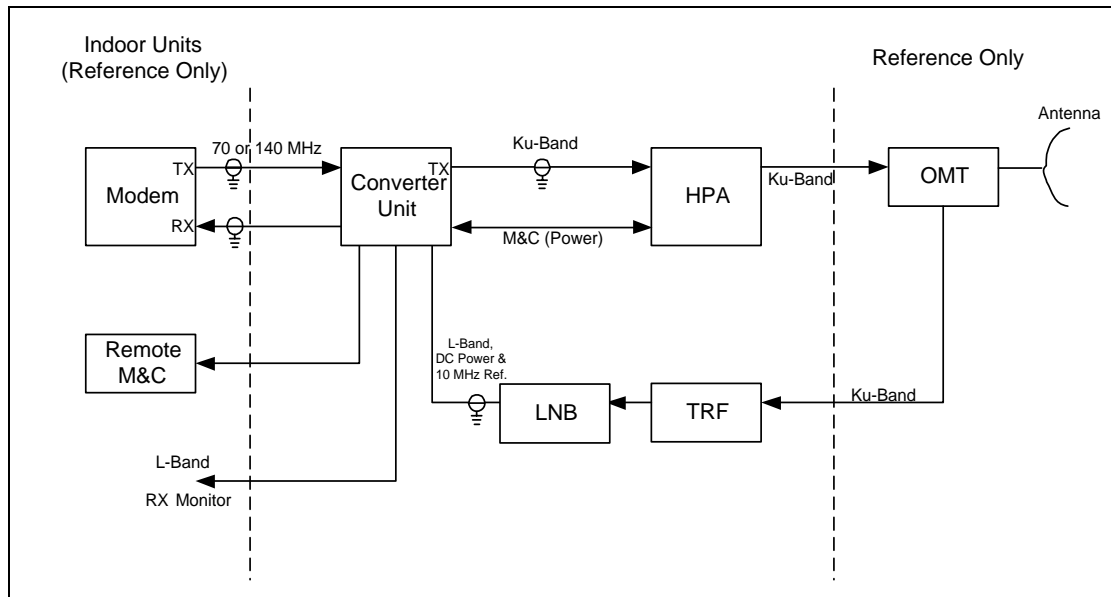

Figure 1-4. Single Thread KST-2000B Block Diagram

1.1.7 Redundant System

A block diagram of a redundant KST-2000A system is shown in Figure 1-5. For the KST-2000B, LNAs replace the LNA's. The KST-2000A/B contains all the logic and circuitry to sense the need to switch channels and to drive the RF switches.

The basic operation of the redundant system is identical to the single thread except that two independent TX and RX channels are provided. Initial selection of TX and RX channels is via the remote M&C or keypad.

During operation, and when a fault is detected in one channel, an automatic switchover to the other channel occurs. The RJU-2000 provides IF I/O selection and converter interface connections.

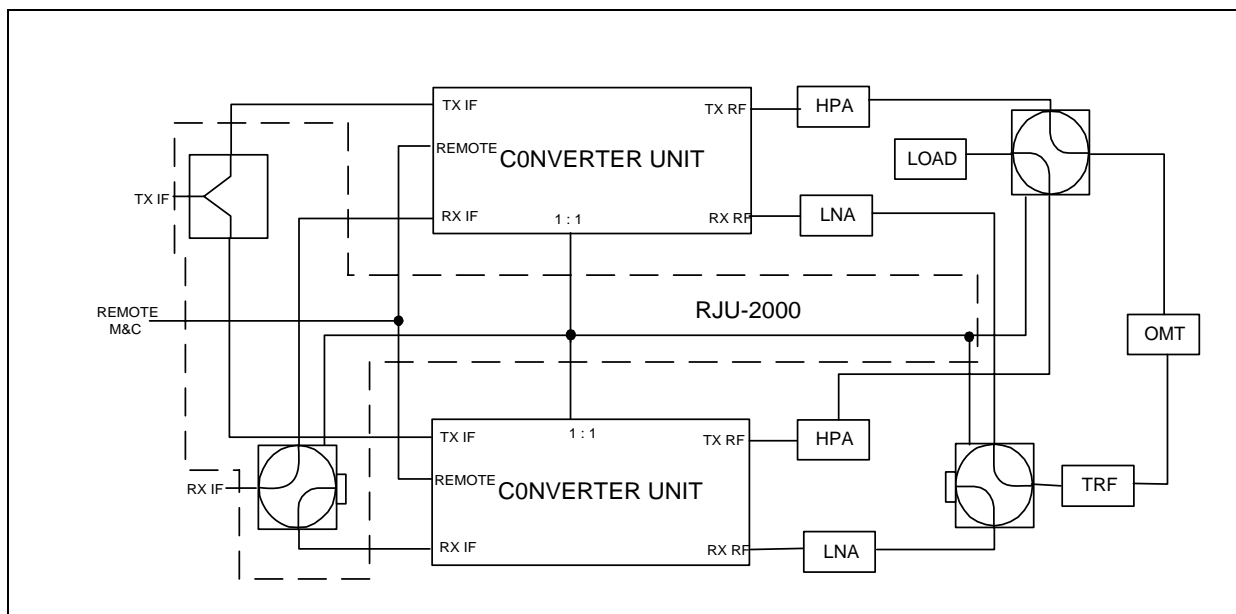

Figure 1-5. Redundant KST-2000A System Block Diagram

1.2 Specifications

The basic KST-2000A/B specifications are listed in this section.

| | |
|-----------|---------------------------------|
| Table 1-2 | Converter Unit Specification |
| Table 1-3 | System Transmit Characteristics |
| Table 1-4 | LNA Characteristics |
| Table 1-5 | LNB Characteristics |
| Table 1-6 | SSPA Characteristics |

Table 1-2. Converter Unit Specifications

| Converter Transmit Characteristics | | |
|--|---|------------------------------|
| Output Frequency | 13.75 to 14.5 GHz in 1 MHz steps | |
| Input Frequency | 50 to 90 MHz (100 to 180 MHz optional) | |
| Input Power Level | -25 to -45 dBm operational -10 dBm survival | |
| Gain | 42 dB nominal at mid-range user attenuation setting | |
| User Attenuation Range | 0 to 20 dB in 1 dB steps | |
| Power Output at 1 dB Compression | + 15 dBm minimum | |
| Transmit Phase Noise | Exceeds IESS 308/309 requirements | |
| Converter Receive Characteristics | | |
| Input Frequency | KST-2000A 10.95 to 12.75 GHz | KST-2000B 950 to 1700 MHz |
| Output Frequency | 50 to 90 MHz (100 to 180 MHz optional) | |
| Gain | 45 dB maximum | |
| User Attenuation Range | 0 to 20 dB in 1 dB steps | |
| Gain Variation with Frequency (at a fixed temperature) | | |
| Any 40 MHz band | 2.0 dB peak-to-peak | |
| Entire operating band | 3.0 dB peak-to-peak | |
| Power Output at 1 dB Compression | +16 dBm minimum | |
| Power Output Stability over Temperature (at a fixed frequency) | 4.0 dB peak-to-peak | |
| Phase Noise | Exceeds IESS 308/309 requirements | |
| Spurious Signals | | |
| Signal Related | -50 dBc at -5 dBm output -35 dBc at <250 kHz from carrier | |
| Non-Signal Related | -87 dBm max referenced to converter input for the KST-2000A -126 dBm max referenced to the LNB input for the KST-2000B | |
| Third Order Products | -33 dBc for two carriers each at +6 dBm | |
| Auxiliary Output Monitor | | |
| Frequency | 950 to 1700 MHz | |
| Gain | 20 dB relative to carrier input | |
| Connector | Type N, female, 50Ω | |

Table 1-2. Converter Unit Specifications (Continued)

| General Converter Characteristics (Continued) | |
|--|---|
| Prime Power | 85 to 264 VAC, 47 to 63 Hz, <200 W(Optional -48 VDC input) |
| Keypad/Display Interface | Weatherproof 16 character LED display with Up (▲), Down (▼), Left (◀), Right (▶), [Clear] and [Enter] pushbuttons |
| Serial Data Interface (User Selectable) | EIA-232, EIA-485, or EIA-422 half duplex |
| Serial Data Baud (User Selectable) | 300, 600, 1200, 2400, 4800, 9600, 19200 |
| Discrete Alarm Outputs Uplink Summary Alarm Downlink Summary Alarm System Summary Alarm | Form "C" Relay Contacts Form "C" Relay Contacts Form "C" Relay Contacts |
| External LED Indicators | Prime Power On/TX RF ON Summary Fault |
| IF Input/Output Connectors | Type N Female, 50Ω |
| TX Output/RX Input Connectors | Type N Female, 50Ω |
| Size | 21.75 H x 8.25W x 8.00D inches (55.2H x 20.95W x 20.32D cm) |
| Weight | 33 lbs. (16 kg) |
| Temperature | -40 to +55°C (-40 to +131°F) operational -50 to +75°C (-67 to +167°F) survival |

Table 1-3. System Transmit Characteristics (with SSPAs of ≤ 40W)

| Parameter | Characteristics |
|---|---|
| Gain Stability over temperature, AGC on, fixed frequency | 2.0 dB peak-to-peak |
| Gain variation with frequency 70 ± 20 MHz 140 ± 40 MHz | 2.0 dB peak-to-peak 3.0 dB peak-to-peak |
| Spurious signals Signal related < 250 kHz Non-signal related | -50 dBc at 6 dB below P ₁ dB -35 dBc at 6 dB below P ₁ dB -24 dBm/4 kHz for 2W unit -21 dBm/4 kHz for 4W unit -18 dBm/4 kHz for 8W unit -15 dBm/4 kHz for 16W unit -13 dBm/4 kHz for 25W unit -13 dBm/4 kHz for 32W unit -12 dBm/4 kHz for 40W unit |

Table 1-4. LNA Characteristics

| LNA Specification | |
|-----------------------------|--|
| Input VSWR | 1.25:1 max. |
| Output VSWR | 1.25:1 max |
| Gain Flatness: | |
| 10.95 to 12.75 GHz | ± 2.0 dB/full band ± 0.50 dB/40 MHz |
| 10.95 to 11.7 GHz | ± 1.5 dB/full band ± 0.25 dB/40 MHz |
| 11.7 to 12.2 GHz | ± 1.5 dB/full band ± 0.25 dB/40 MHz |
| 12.25 to 12.75 GHz | ± 1.5 dB/full band ± 0.25 dB/40 MHz |
| Gain vs. Temperature | ± 1.5 dB Max. |
| Operating Temperature | -40 to +60°C (-40 to + 140°F) |
| 1 dB Gain Comp. Pt. | +10 dBm +8 dBm or +20 dBm (optional) |
| Third Order Intercept Point | +20 dBm +18 dBm or +30 dBm (optional) |
| Group Delay: | |
| Linear | 0.01 ns/MHz |
| Parabolic | 0.001 ns/MHz ² |
| Ripple | 0.1 ns/peak-to-peak |
| Power Connector | Powered by the KSAT through the coax |
| RF Input W/G | WR-75 Cover |
| Input Power, Nominal | +12 to +24 VDC at 100 mA |

Table 1-5. LNB Characteristics

| LNB Characteristics | |
|-----------------------|---|
| Frequency | 10.95 to 11.70 GHz 11.70 to 12.20 GHz 12.25 to 12.75 GHz |
| Gain @ 25°C | 55 dB minimum, 60 dB typical |
| 1 dB Gain Comp. PT. | + 10 dBm, minimum |
| Noise Figure @ 25°C | 0.9 dB, typical |
| RF Input Waveguide | WR-75 |
| Input Power | + 15 V, 400 mA maximum |
| Output | Type N female, 50Ω |
| Operating Temperature | -40 to +55°C (-40 to 131°F) |
| Operating Humidity | 0 to 100% RH |
| Storage Temperature | -50° to +80°C (-58 to +176°F) |
| Size | 2.5W x 5.7L x 1.6H inches (approximately) (6.5W x 14.5L x 4H cm) |
| Weight | < 2 lbs. (< 0.9 kg) |

Table 1–6. SSPA Characteristics

| Parameter | 2W SSPA | 4W SSPA | 8W SSPA | 16W SSPA | 25W SSPA | 32W SSPA | 40W SSPA | 80W SSPA |
|---|-----------------------------------|--------------------------------|--------------------------------|--|---|--|--|----------------------------------|
| Frequency Range | 13.75 to 14.5 GHz (See Note 1) | 13.75 to 14.5 GHz | 13.75 to 14.5 GHz | 13.75 to 14.5 GHz | 13.75 to 14.5 GHz | 13.75 to 14.5 GHz | 13.75 to 14.5 GHz | |
| Power output at 1 dB Compression at 25° C: Guaranteed | + 33 dBm | + 36 dBm | + 39 dBm | + 42 dBm | + 44 dBm | + 45 dBm | + 46 dBm | |
| Third Order Intermodulation | + 41 dBm (Intercept pt) | + 44 dBm (Intercept pt) | + 47 dBm (Intercept pt) | + 50 dBm (Intercept pt) | + 52 dBm (Intercept pt) | + 53 dBm (Intercept pt) | + 54 dBm (Intercept pt) | |
| Gain (Nominal) | 27 dB | 30 dB | 33 dB | 38 dB | 40 dB | 41 dB | 44 dB | |
| Gain Variation with Temperature | 2.0 dB p-p | 2.0 dB p-p | 2.0 dB p-p | 2.0 dB p-p | 2.0 dB p-p | 2.0 dB p-p | 2.0 dB p-p | |
| Input Connector | Type N, Female, 50Ω | Type N, Female, 50Ω | Type N, Female, 50Ω | Type N, Female, 50Ω | Type N, Female, 50Ω | Type N, Female, 50Ω | Type N, Female, 50Ω | |
| Output Connector | WR-75 W/G flange | WR-75 W/G flange | WR-75 W/G flange | WR-75 W/G flange | WR-75 W/G flange | WR-75 W/G flange | WR-75 W/G flange | |
| Input Power | +9.75 VDC from converter (30W) | +9.75 VDC from converter (36W) | +9.75 VDC from converter (90W) | 85-264 VAC, 47-63 Hz (180W), Optional –36 to -72 VDC | 85-264 VAC, 47-63 Hz (360W) Optional –36 to -72 VDC | 85-264 VAC 47-63 Hz (380W) Optional –36 to -72 VDC | 85-264 VAC 47-63 Hz (390W) Optional –36 to -72 VDC | Refer to amplifier documentation |
| Weight | 5 lb (2.3 kg) | 8 lb (3.7 kg) | 9 lb (4.0 kg) | 24 lb (11 kg) | 47 lb (21 kg) | 52 lb (21 kg) | 52 lb (21 kg) | |

Notes:

1. Optional: 14.0 to 14.5 GHz.
2. Optional: 13.75 to 14.5 GHz.

NOTES:

Chapter 2. INSTALLATION

This chapter provides system equipment and external connections information for both single thread and redundant systems. Refer to Appendix C (single-thread equipment) and Appendix D (redundant equipment) for installation procedures specific to particular mounting applications.

2.1. Single-Thread System Components

The standard components delivered with a single-thread system include:

| QTY | Description |
|-------------|---|
| 1 | Base converter unit |
| 1 | HPA (no HPA necessary for the +15dBm requirement) |
| 1 | LNA (KST-2000A system) or LNB (KST-2000B system) |
| As Required | 12ft (3.66m) Prime power cables for all converter units and applicable amplifiers |
| As Required | 5ft (1.52m) Interlink cabling |
| As Required | Mounting hardware for a spar mounted offset antenna. (see <i>Note</i>) |

Note: Antenna type shall be indicated when ordering the KST-2000A/B unit.

2.2. Redundant System Components

The standard delivered components included with a redundant system are:

| QTY | Description |
|-------------|--|
| 2 | Base converter units |
| 2 | HPA (no HPA necessary for the +15dBm requirement) |
| 2 | LNA (KST-2000A system) or LNB (KST-2000B system) |
| As Required | 12ft (3.66m) Prime power cables for all converter units and applicable amplifiers |
| 1 | RJU-2000 switch junction box |
| As Required | Interlink cabling from the base converters to the RJU-2000 switch junction box |
| 1 | 15ft (4.57m) Interlink cable for the RX 1:1 waveguide LNA assembly (mounted directly to the OMT) |
| 1 | 10ft (3.05m) Interlink cable for the TX 1:1 waveguide HPA assembly (TX switching for +15dBm 1:1 system is provided via coaxial switch) |
| 1 | 3ft (1m) Flexible waveguide (connects the output of TX switch to the TX port of the OMT) |
| As Required | Mounting hardware for a spar mounted offset antenna. <i>(see Note)</i> |
| 1 | M&C mating connector |

Note: Antenna type shall be indicated when ordering the KST-2000A/B unit.

2.3. Description of Options

Table 2-1. Description of Options

| |
|---|
| KST2000A TX ONLY OPTION (System ordered as KST-2000A. KST-2000B TX only N/A) |
| LNA OPTIONS (10.95 to 12.75GHz): |
| (KST2000A only) 85° KLNA noise temperature |
| (KST2000A only) 60db gain KLNA |
| (KST2000A only) 85° KLNA noise temperature and 60 dB gain |
| (KST2000A only) Special LNA requirements outside those previously indicated |
| LNB OPTIONS (discrete narrow bands at 1.1db max NF only): |
| (KST2000B only) 10.95 to 11.70 GHz Europe and also Intelsat (11.20 to 11.70 GHz) |
| (KST2000B only) 11.70 to 12.20 GHz North American |
| (KST2000B only) 12.25 to 12.75 GHz Aussat |
| MOUNTING HARDWARE OPTIONS: |
| Standard Prodelin spar offset antenna (base converter units are pole-mounted for redundant systems) |
| Standard Channel Master spar offset antenna (base converter units are pole-mounted for redundant systems) |
| Non-standard single thread converter pole-mount Kit |
| No mounting hardware beyond the "pick off points" on the completed assembly |
| For mounting requirements outside those previously indicated, please consult the factory for availability. |
| CABLING OPTIONS: |
| No RF (and IF for 1:1 system) or control cabling. Includes only the prime power cable(s) and applicable MS connectors |
| For cabling requirements outside those previously indicated, please consult the factory for availability. |

2.4. Electrical Connections

2.4.1. Converter Unit

The external connections on the converter unit are shown in Figure 2-1 and listed in Table 2-2. The connections are described in the following paragraphs.

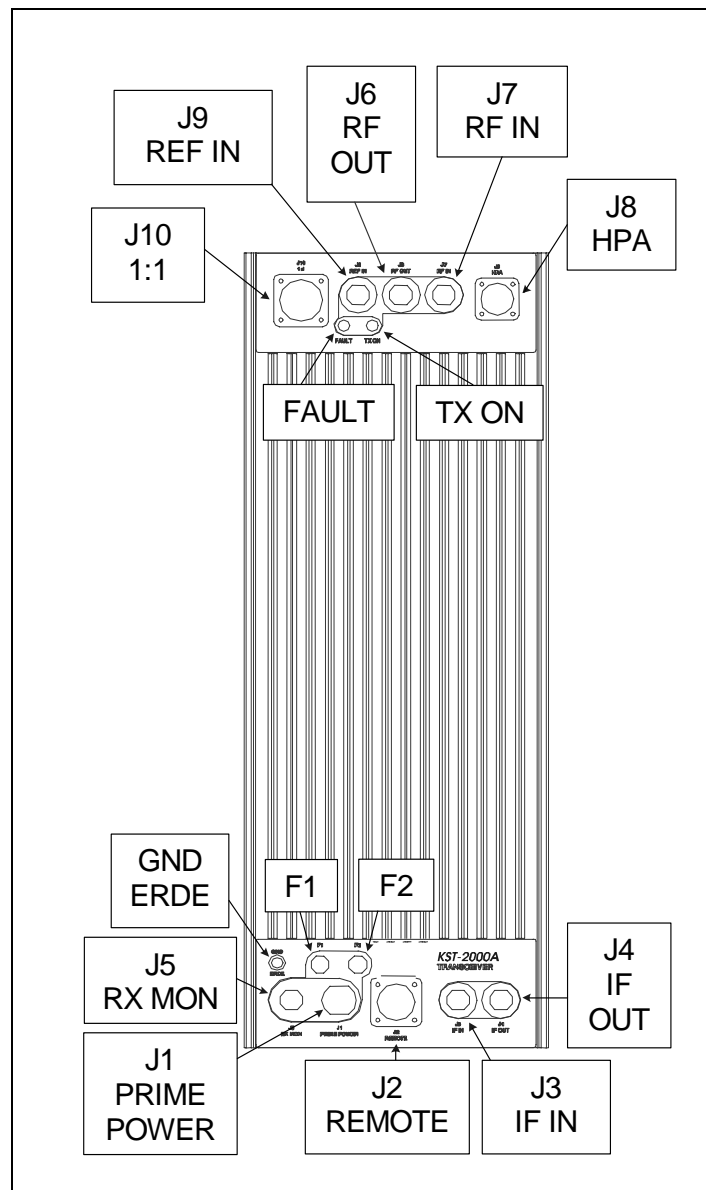

Figure 2-1. I/O View of KST-2000A/B Converter Unit

Table 2-2. Converter Unit External Connections

| Ref. | Name | Connector Type | Function | |
|------|-------------|-------------------------|--|---|
| J1 | PRIME POWER | 3/4 pin circular Male | Prime AC/DC Power Input | |
| J2 | REMOTE | 26 pin circular, Female | Remote M&C Interface | |
| J3 | IF IN | Type N, Female | TX IF Input 70 MHz or optionally 140 MHz | |
| J4 | IF OUT | Type N, Female | RX IF Output 70 MHz or optionally 140 MHz | |
| J5 | RX MON | Type N, Female | L-Band Receive Monitor (970-1700MHz) | |
| J6 | RF OUT | Type N, Female | 13.75 to 14.5 GHz TX out to HPA | |
| J7 | RF IN | Type N, Female | <u>KST-2000A</u> 10.95 to 12.75 GHz RX in from LNA | <u>KST-2000B</u> 950 to 1700 MHz from LNB |
| J8 | HPA | 10 pin circular, Female | HPA M&C Interface | |
| J9 | REF IN | Type N, Female | External system reference input, 5 or 10 MHz at 6 dBm min. | |
| J10 | 1:1 | 32 pin circular, Female | Redundancy Control | |

2.4.1.1 AC Prime Power Connector (J1)

Prime power is supplied to the converter unit (and for SSPAs of ≤ 8 Watts) through a 3-pin circular male connector (J1) as in Figure 2-2. Prime power input requirements are 85 to 264 VAC, 47 to 63 Hz, 200 watts. The J1 connections are listed in Figure 2-2 for pin assignments.

Note: Pin C (ground) is adjacent to the connector notch.

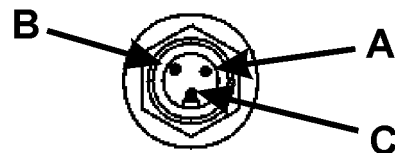

| Pin | Function | Color |
|-----|----------|--------------|
| A | Line | Brown |
| B | Neutral | Blue |
| C | Ground | Green/Yellow |

Mating connection is molded power cord
Comtech PN CA/84914-0223

Figure 2-2. Prime Power Input (J1)

2.4.1.2 Optional –48VDC Prime Power Connector (J1)

Prime power is supplied to the converter unit (and for SSPAs of ≤ 8 Watts) through a 4-pin circular male connector (J1). For the converter unit, the prime power input requirement is -36 to -48 VDC, 200 watts.

| Optional –48VDC Power Connection | |
|--|------------|
| Pin | Function |
| A | + VDC |
| B | Ground |
| C | - VDC |
| D | No Connect |
| Mating connector is a Comtech P/N CN/STPG04F01(Ampheno PT06E-12-4S(SR)) | |

2.4.1.3 Remote Connector (J2)

The Remote Connector (J2) is a 26-pin, circular, female connector (P/N: PT06E16-26P(SR)). It is used to allow remote control and monitoring of KST-2000A/B operating parameters. Interface is via EIA-232, EIA-485, or EIA-422 half-duplex. Refer to Table 2-3 for pin assignments.

Note: The user must assemble this cable. Figure 2-3 shows the connections for an EIA-232 adapter for use with a PC COM port.

Table 2-3. Remote M&C Connector (J2) Pin Assignments

| Pin | Signal | Description |
|-----|--------------------------------|-------------------------------------|
| A | -TX/-RX or –RX only (see Note) | – EIA-485 TX/RX or – EIA-422 RX |
| B | -TX/-RX or –TX only (see Note) | –EIA-485 TX/RX or – EIA-422 TX |
| C | +TX/+RX or +RX only (see Note) | + EIA-485 TX/RX or + EIA-422 RX |
| D | +TX/+RX or +TX only (see Note) | + EIA-485 TX/RX or + EIA-422 TX |
| E | RXD | EIA-232 receive data |
| F | RTS | EIA-232 ready to send (tied to CTS) |
| G | TXD | EIA-232 transmit data |
| H | DSR | EIA-232 data set ready |
| J | GND | Ground |
| K | LNA Power | +15 VDC to LNA |

| | | |
|---|---------------------|--------------------------------------|
| L | LNA Power Return | +15 VDC Return from LNA |
| M | RESET | Reset (momentary low resets system) |
| N | GND | Ground |
| P | CTS | EIA-232 clear to send (tied to RTS) |
| R | GND | Ground |
| S | +12V (KP10 Power) | KP10 power supply output |
| T | 2/4 wire (see note) | EIA-485/EIA-422 operation selection |
| U | UL_FLT_NC | Uplink fault relay, closed = fault |
| V | UL_FLT_COM | Uplink fault relay common |
| W | UL_FLT_NO | Uplink fault relay, open = fault |
| X | DL_FLT_NC | Downlink fault relay, closed = fault |
| Y | DL_FLT_COM | Downlink fault relay common |
| Z | DL_FLT_NO | Downlink fault relay, open = fault |
| a | SUM_FLT_NO | Summary fault relay, open = fault |
| b | SUM_FLT_NC | Summary fault relay, closed = fault |
| c | SUM_FLT_COM | Summary fault relay, common |

Notes:

1. These signals can be configured as EIA-485, 2-wire, half-duplex or EIA-422, 4-wire, half-duplex.
2. In 2-wire mode, pins A and B are tied together as are pins C and D.
3. To select 2-wire operation, pin T is left open. Tie pin T to ground for EIA-422 (4-wire) operation.

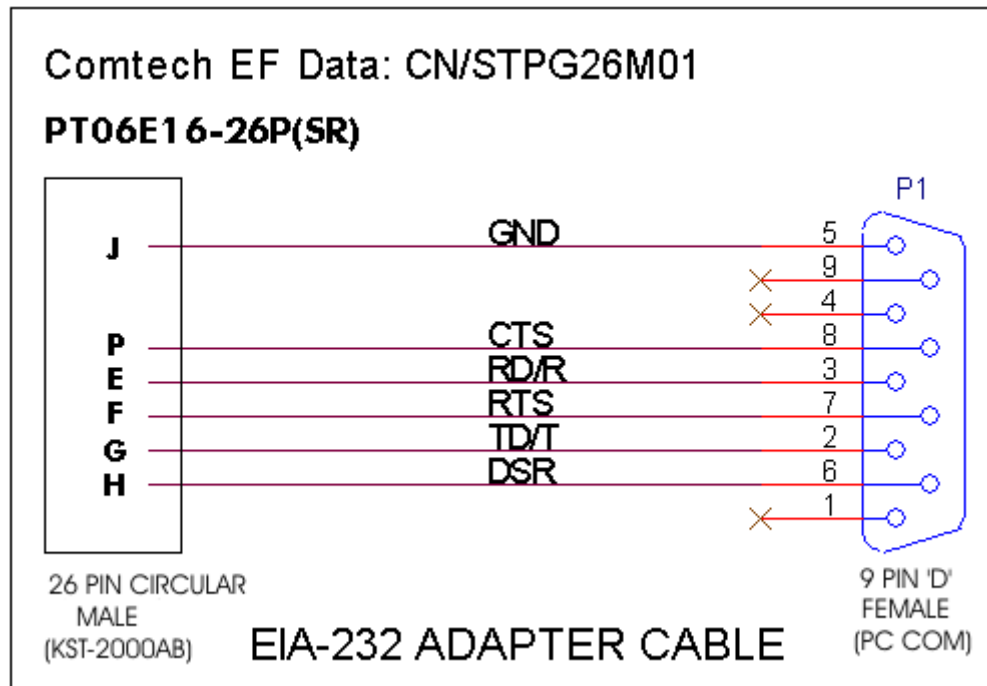

Figure 2-3. Serial (EIA-232) Adapter Cable Wiring Diagram

2.4.1.4 IF IN Connector (J3)

The IF IN connector (J3) is a Type N, female connector used to connect the IF at 70 MHz (140 MHz optional) at -25 to -45 dBm from the modem to the converter unit. Either 50Ω or 75Ω cables may be used to connect to J3.

2.4.1.5 IF OUT Connector (J4)

The IF OUT connector (J4) is a Type N, female connector used to connect the IF at 70 MHz (140 MHz optional) from the converter unit to the modem. Either 50Ω or 75Ω cables may be used to connect to J4.

2.4.1.6 RX MON Connector (J5)

The RX MON connector (J5) provides the received (downlink) signal at L-Band (950 to 1700 MHz) for monitoring. This signal has a gain of 20 dB relative to the carrier. Connector J5 is a Type N, female connector. Nominal output impedance is 50Ω.

| Parameter | Frequency | Frequency | Frequency |
|--|--------------------|--------------------|-------------------|
| Ku-Band Frequency, GHz | 10.95 to 11.699 | 11.70 to 12.249 | 12.25 to 12.75 |
| Subtract the DRO Frequency, GHz | -10.0 | -10.75 | -11.3 |
| RX MON at L-Band, MHz | 950 to 1699 | 950 to 1499 | 950 to 1450 |

2.4.1.7 RF OUT Connector (J6)

The RF OUT connector (J6) is a type N, female, 50Ω connector used to connect the converter unit's output at Ku-Band (uplink) to an HPA. Power output at 1 dB compression is +15 dBm minimum.

2.4.1.8 RF IN Connector (J7)

The RF IN connector (J7) is a type N, female, 50Ω connector used to connect the LNA's output at Ku-Band (downlink) to the converter unit for the KST-2000A. This same connector is used to connect the LNB's output at L-Band to the converter unit for the KST-2000B.

2.4.1.9 HPA Connector (J8)

The HPA connector (J8) is a 10 pin circular, female (ITT #KPT02E-12-105) connector used for HPA M&C and power functions. Refer to Table 2-5 for pin assignments for 2, 4, 8, 16, 25, 32, and 40 watt SSPAs. Pin assignments vary based on the amplifier type selected.

Table 2-4. HPA Connector (J8) Pin Assignments (CEFD SSPA)

| Pin | Signal | Description |
|-----|----------|--|
| A | IPA | Communications line A |
| B | IPB | Communications line B |
| C | +10V | +10V Power Supply Output (N/A on 16, 25, 32 & 40W) |
| D | +10V | +10V Power Supply Output (N/A on 16, 25, 32 & 40W) |
| E | +10V | +10V Power Supply Output (N/A on 16, 25, 32 & 40W) |
| F | +10V | +10V Power Supply Output (N/A on 16, 25, 32 & 40W) |
| G | +10V_RTN | +10V Power Supply Output (N/A on 16, 25, 32 & 40W) |
| H | +10V_RTN | +10V Power Supply Output (N/A on 16, 25, 32 & 40W) |
| J | +10V_RTN | +10V Power Supply Output (N/A on 16, 25, 32 & 40W) |
| K | +10V_RTN | +10V Power Supply Output (N/A on 16, 25, 32 & 40W) |

Notes:

1. For a CEFD SSPA, J8 (external circular connector) is routed internally to J10 on the M&C PC assembly AS/8876 (refer to Table 2-4).
2. Non-KST specific SSPA application, J8 (external circular connector) is routed internally to J11 on the M&C PC assembly AS/8876, (refer to Table 2-5).
3. For a TWTA application, J8 (external circular connector) is routed internally to J12 on the M&C PC assembly AS/8876, (refer to Table 2-6).

Table 2-5. HPA Connector (J8) Pin Assignments (Non-KST Specific SSPA)

| SSPA Pin | Converter Pin | Signal | Description |
|----------|---------------|---------|---|
| H | A | RF_ENA | RF enable, open collector output, active low |
| – | B | N/C | Not connected |
| – | C | N/C | Not connected |
| – | D | N/C | Not connected |
| C | E | THERM | Thermistor input connection |
| – | F | N/C | Not connected |
| D | G | HPA_IN1 | SSPA summary fault input, active low |
| G/R | H | CMD_RTN | Command return (tie to SSPA GND) |
| E | J | ANA_IN | Analog input from SSPA (0 to +10VDC) Output Power |
| a | K | GND | Signal ground reference |

Table 2-6. HPA Connector (J8) Pin Assignments (TWTA Connection)

| Pin | Signal | Description |
|-----|--------------|--|
| A | HV_EN | High voltage enable, open collector output, active low |
| B | HTR_STB Y | Heater standby, open collector output, active low |
| C | FLT_RST | Fault reset, open collector output, active low |
| D | HPA_IN1 | Input from TWTA, heater timer complete, active low |
| E | HPA_IN2 | Input from TWTA, TWT temperature fault, active low |
| F | HPA_IN3 | Input from TWTA, high voltage on, active low |
| G | HPA_IN4 | Input from TWTA, summary fault, active low |
| H | GND | Status/control return |
| J | ANA_IN | Analog input from TWTA (0 to +10VDC) |
| K | GND | Analog signal return |

2.4.1.10 REF IN Connector (J9)

The REF IN connector (J9) allows the user to operate the system with an external reference instead of the built-in system reference. An external signal of 5 or 10 MHz, at +6 dBm minimum, may be applied to the 50Ω, Type N, female connector.

2.4.1.11 1:1 Connector (J10)

The 1:1 (J10) connector is a 32-pin circular, female connector used in redundant applications for unit communications and switch control. Refer to Table 2-7 for pin assignments.

Table 2-7. 1:1 Connector (J10) Pin Assignments

| Pin | Signal | Description |
|-----|------------|--|
| A | UL_FLT_OUT | U/L Fault output – wires to adjacent unit UL_FLT_IN |
| B | DL_FLT_OUT | D/L Fault output – wires to adjacent unit DL_FLT_IN |
| C | TX_SW_CMD | Transmit switch command – momentary +28 VDC output |
| D | RX_SW_CMD | Receive switch command – momentary +28 VDC output |
| E | IF_SW_CMD | IF switch command – momentary +28 VDC output |
| F | UL_OL_IND | U/L online indicator – wires to adjacent unit UL_OL_IN |
| G | DL_OL_IND | D/L online indicator – wires to adjacent unit DL_OL_IN |
| H | ENA_OUT | Redundancy enable – wires to adjacent unit ENA_IN |
| J | MODE_1_OUT | Mode output – wires to adjacent unit MODE_1_IN |
| K | MODE_2_OUT | Mode output – wires to adjacent unit MODE_2_IN |
| L | MODE_2_IN | Mode input – wires to adjacent unit MODE_2_OUT |
| M | MODE_1_IN | Mode input – wires to adjacent unit MODE_1_OUT |
| N | DL_OL_IN | D/L online – wires to adjacent unit DL_OL_IND |
| P | UL_OL_IN | U/L online input – wires to adjacent unit UL_OL_IND |
| R | DL_FLT_IN | D/L fault input – wires to adjacent unit DL_FLT_OUT |
| S | UL_FLT_IN | U/L fault input – wires to adjacent unit UL_FLT_OUT |
| T | CONTINUITY | Continuity detection – wires to adjacent unit CONT RTN |
| U | A/B_UNIT | Unit designator GND = A unit, open = B unit |
| V | ENA_IN | Enable input – wires to adjacent unit ENA_OUT |
| W | IF_IND_B | IF switch, position B indicator input |
| X | IF_IND_A | IF switch, position A indicator input |
| Y | RX_IND_B | RX switch, position B indicator input |
| Z | RX_IND_A | RX switch, position A indicator input |
| a | TX_IND_B | TX switch, position B indicator input |
| b | TX_IND_A | TX switch, position A indicator input |
| c | IF_IND_COM | IF switch indicator common |
| d | RX_IND_COM | RX switch indicator common |
| e | TX_IND_COM | TX switch indicator common |
| f | IF_CMD_COM | IF switch command common |
| g | RX_CMD_COM | RX switch command common |
| h | TX_CMD_COM | TX switch command common |
| j | CONT_RTN | Continuity return – wires to adjacent unit continuity |

2.4.2. Data SSPAs

2.4.2.1 2 and 4 Watt SSPA Connections

The 2 and 4 Watt SSPAs have a Type N, female (50Ω) connector (J1) at one end for the Ku-Band input and a WR-75 waveguide isolator and waveguide filter (J2) at the other end for the Ku-Band output. Also at the input is the M&C control/power cable connector (J3) for connection to the HPA (J8) connector on the converter unit.

2.4.2.2 8 Watt SSPA Connections

The 8 Watt SSPA has a Type N, female (50Ω) connector (J1) at one end for the Ku-Band input and a WR-75 waveguide isolator (J2) at the other end for the Ku-Band output. Also at the input is the M&C control/power cable connector (J3) for connection to the HPA (J8) connector on the converter unit. The HPA's cooling fan is externally connected at J4 at the factory, and this connection should not be removed. Refer to Table 2-8 for pin assignments.

Table 2-8. Fan (J4) Pin Assignments

| Pin | Function |
|-----|-------------|
| A | +FAN (+12V) |
| B | -FAN (GND) |
| C | N/C |

2.4.2.3 16 Watt SSPA Connections

The 16 Watt SSPA input and output connections are shown in Figure 2-4

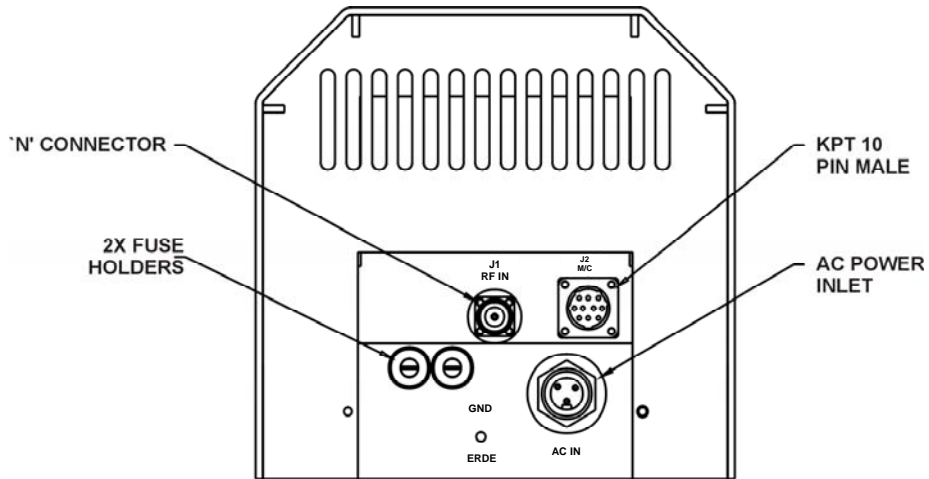
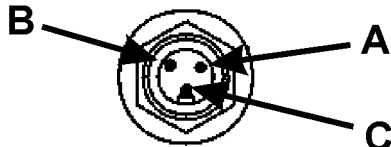

Figure 2-4. 16Watt SSPA

Note: When replacing fuses in the 16 Watt SSPA, use 6.3 amp, 3AG fuses, (2 each).



AC Line Input Connector (J3)

| AC Power Connection | | |
|---------------------|----------|--------------|
| Pin | Function | Color |
| A | Line | Brown |
| B | Neutral | Blue |
| C | Ground | Green/Yellow |

Mating connection is molded power cord
Comtech PN CA/84914-0223

| Optional -48V DC DC Power Connection | |
|--------------------------------------|------------|
| Pin | Function |
| A | + VDC |
| B | Ground |
| C | - VDC |
| D | No Connect |

Mating connector is a Comtech P/N
CN/STPG04F01(Amphentol PT06E-12-
4S(SR))

| Connection | Function | Description | Mating Connector |
|-------------------|------------------|-----------------------|-------------------------|
| J1 | RF Input | N-Type, Female | N-Type, Male |
| J2 | M&C Interface | ITT#KPT02E-12- 105 | ITT#KPT06E-12- 105 |
| J3 | AC/DC-Line | Main Power | See above tables |

Figure 2-5. I/O Connectors for the 16 Watt SSPA

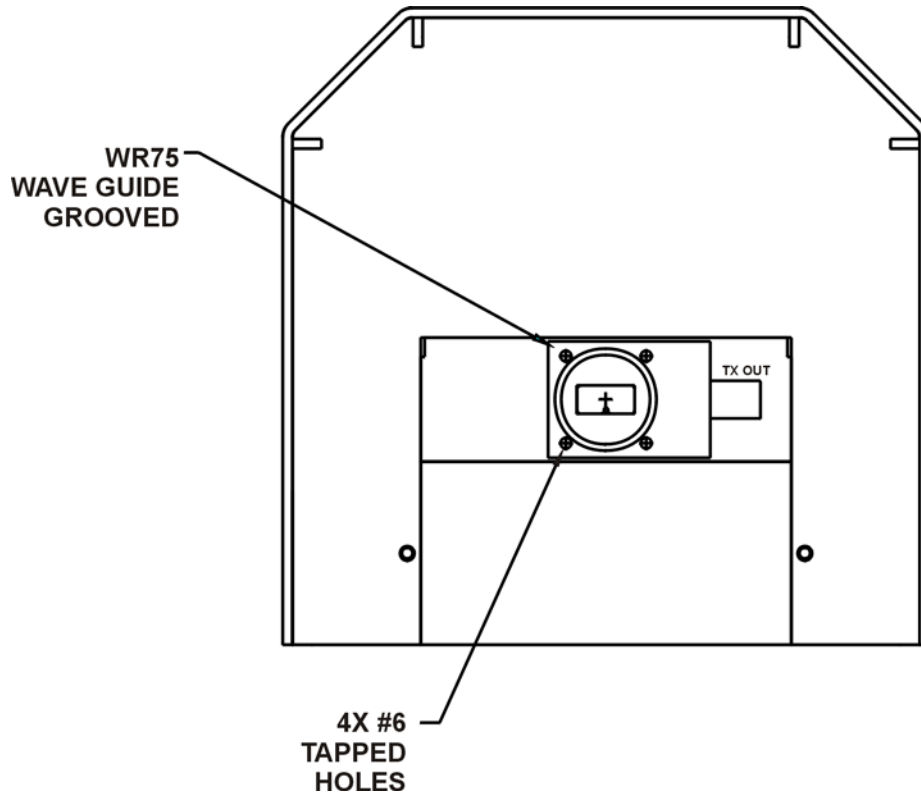

**Figure 2-6. Output Connection for the 16 Watt SSPA
(Waveguide)**

2.4.2.4 25 / 32 / 40 Watt SSPA Connections

The 25/32/40 Watt SSPA input and output connections are shown in Figure 2-7.

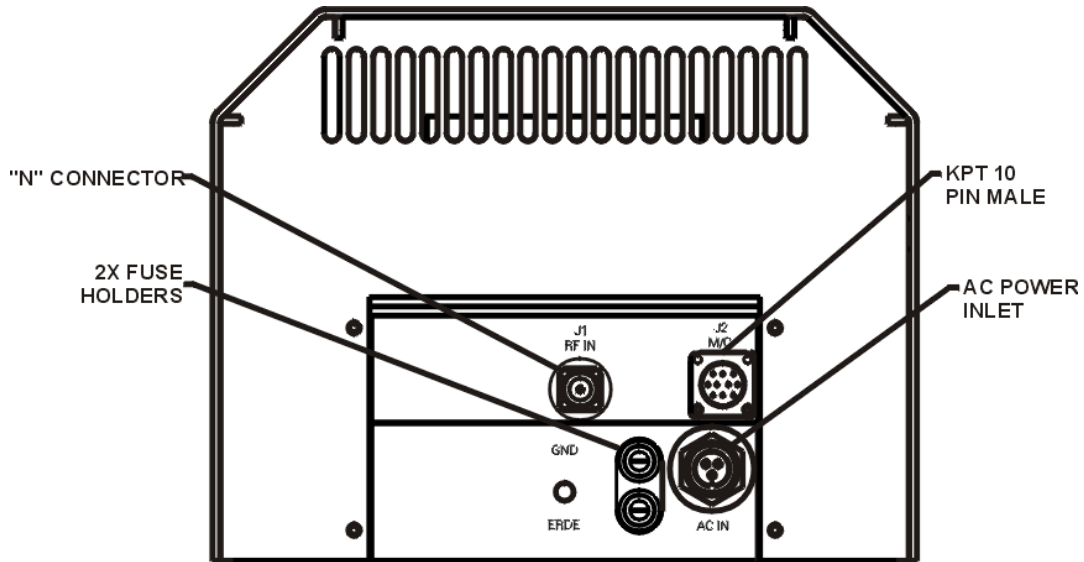

Figure 2-7. 25/32/40 Watt SSPA

Note: When replacing fuses in the 25/32/40 Watt SSPA, use 6.3 amp, 3AG fuses, (2 each).

AC Line Input Connector (J3)

| AC Power Connection | | |
|--|----------|--------------|
| Pin | Function | Color |
| A | Line | Brown |
| B | Neutral | Blue |
| C | Ground | Green/Yellow |
| Mating connection is molded power cord Comtech PN CA/84914-0223 | | |

| Optional -48V DC DC Power Connection | |
|--|------------|
| Pin | Function |
| A | + VDC |
| B | Ground |
| C | - VDC |
| D | No Connect |
| Mating connector is a Comtech PN CN/MS-PLST4F01(ITT Cannon CA06COM-E-18-10SB(ROHS 4-06)) | |

| Connection | Function | Description | Mating Connector |
|------------|---------------|-------------------|-------------------|
| J1 | RF Input | N-Type, Female | N-Type, Male |
| J2 | M&C Interface | ITT#KPT02E-12-105 | ITT#KPT06E-12-105 |
| J3 | AC/DC-Line | Main Power | See tables above |

Figure 2-8. I/O Connectors for the 25/32/40 Watt SSPA

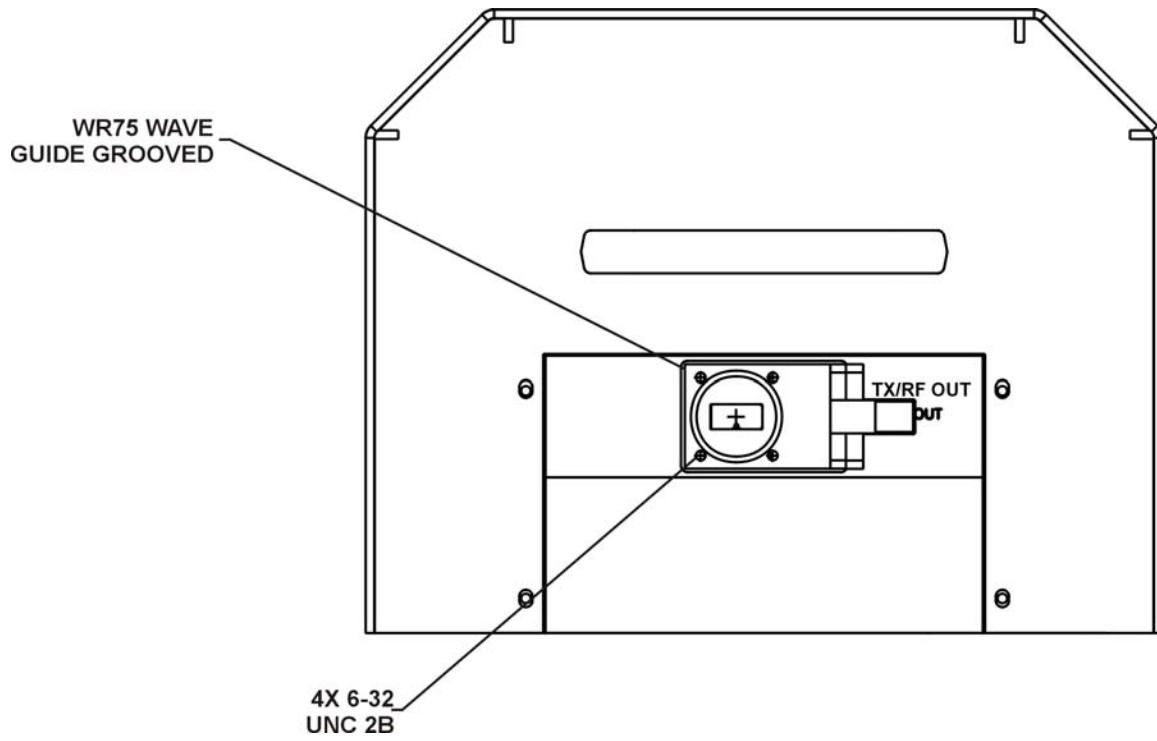

**Figure 2-9. Output Connection for the 25/32/40 Watt SSPA
(Waveguide)**

2.4.2.5 80 Watt SSPA Connections

Note: The data is supplied by the vendor and accompanies the unit.

2.4.3. LNA Connections

Note: The power supply for the LNA is supplied by the KST-2000A.

The RF input of the LNA is a WR-75 waveguide flange. The RF output of the LNA is a type N, female, 50 Ω connector. The LNA power supply is applied to the RF output connector, normally +15 V at 250 mA.

2.4.4. LNB Connections

Note: The power supply for the LNB is supplied by the KST-2000B.

The RF input of the LNB is a WR-75 waveguide flange. The RF OUT/REF/PWR IN connector of the LNB is a type N, 50 Ω connector. It supplies the block-converted output of 950 to 1700 MHz, and accepts +15 V at 400 mA, and a 10 MHz reference signal.

Chapter 3. OPERATION

This chapter provides the following information: Initial setup (single-thread system), initial setup (redundant system), RJU-2000 Redundant Junction Unit description, 1:1 redundant KST-2000A/B system operation, Up converter description, and Down converter description.

3.1 Initial Setup (Single-Thread System)

This section details the procedures necessary to laboratory test a single-thread KST-2000A/B system for the first time. Refer to Figure 3-1 for system setup.

Note: Ensure that the termination selected for the HPA output is sized to handle the HPA output power.

1. Apply power to the KST-2000A/B.
2. After a few seconds ensure that the GREEN TX ON LED is flashing, and the fault LED is extinguished. Refer to Section 4 if this is not the case.
3. Using a KP-10 or PC equipped with a terminal or Windows™ based M&C program, ensure communication is available to the system M&C, via J2, remote connector. (Refer to M&C software manual, P/N MN/M&CWIN.IOM)

| | | |
|----------------------------------|-------------|--------|
| Default Communication Parameters | Address | 1 |
| | Baud Rate | 9600 |
| | Parity | Even |
| | Stop bits | 2 |
| | Data length | 7 bits |

If the communication parameters for the system are not known, the Windows™ based M&C system has a facility that will search all combinations of address, baud rate, and parity until communication is established with the system.

Using the KP-10 or terminal program, send a miscellaneous command such as EQUIPMENT TYPE (see Appendix B.8) and confirm a response is displayed. The Windows™ based status screen will turn from RED to GRAY when communication with the KST-2000A/B is established.

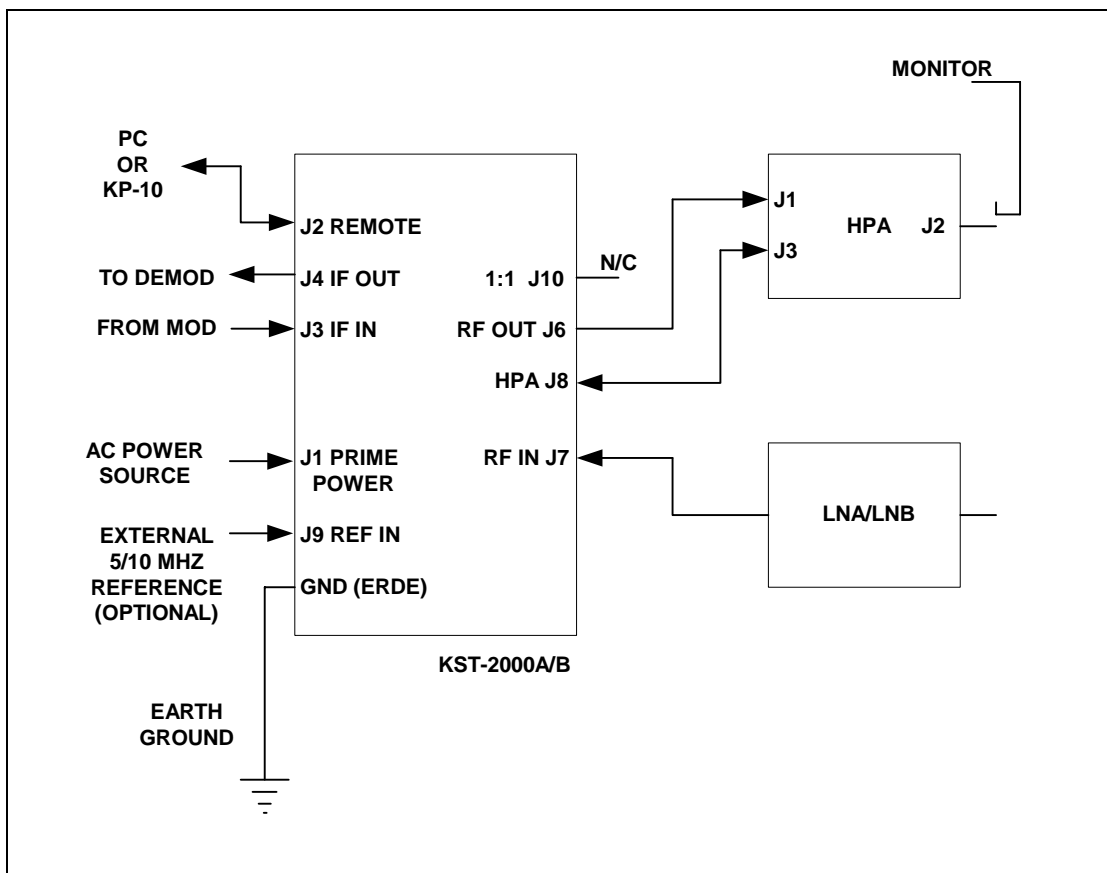

Figure 3-1. Single-Thread System

3.1.1 Uplink Setup

| Step | Procedure | Troubleshooting |
|------|---|---|
| 1 | Apply a 70 MHz (140 MHz) signal at a known level between –25 and –45 dBm to the IF IN (J3) connector of the KST-2000A/B. | The AGC function is selected as ON. The AGC will not function below a – 45 dBm input level. <ol style="list-style-type: none"> 1. If the AGC function is selected as OFF, lower input levels can be used limited only by noise. 2. See Section 3.12 for more information on the AGC function. |
| 2 | Set the up converter to the desired RF TX frequency using the appropriate commands from the KP10 terminal, or Windows™ M&C. | <ol style="list-style-type: none"> 1. See the up converter frequency select command (Appendix B.3). 2. If an error message is received, see Appendix B.2.3 to determine the cause. |
| 3 | Before proceeding, ensure that the HPA is properly terminated. | If a directional coupler and termination is used or an attenuator is used, note the value. |
| 4 | Enable external faults, execute the appropriate HPA Power and Heater commands | See Appendix B.4 HPA commands. |
| 5 | Turn the RF output of the up converter ON. | <ol style="list-style-type: none"> 1. See Appendix B.3 system configuration commands. 2. There should be no up converter faults at this time. |
| 6 | Using an appropriate frequency measuring device, ensure that the output of the HPA (measured through the coupler or attenuator) is at the correct frequency. | <ol style="list-style-type: none"> 1. If an external 5 or 10 MHz source is used, the internal reference will automatically frequency-lock to it. 2. Ensure that there are no reported reference faults using the commands in Appendix B.9, Reference Current Faults. 3. If the internal, high-stability oscillator is used, its frequency can be fine tuned using the reference frequency adjust command. 4. See Appendix B.3. Allow at least 30 minutes warm-up before adjusting the oscillator. |
| 7 | Using an appropriate RF power measuring device, set the up converter attenuation until the power measured at the output of the coupler or attenuator is at the correct value. | See Appendix B.3. |
| 8 | Turn the RF output of the up converter off. | See Appendix B.3. |

3.1.2 Downlink Setup

| Step | Procedures | Troubleshooting |
|---------------------------------|---|---|
| 1 | Apply a signal in the appropriate receive frequency range according to the following table at a known level (approximately –95 dBm) to the LNA or LNB input. | <ol style="list-style-type: none"> 1. If the LNA or LNB is using power supplied by the KST-2000A/B, enable the LNA (or LNB) power – see Appendix B.5. 2. After a 10-minute warm-up, perform an LNA (or LNB) calibration, and enable LNA (or LNB) faults if desired. 3. See Appendix B.5. |
| | <table border="1"> <tr> <td>KST-2000A 10-95 to 12.75 GHz</td> <td>KST-2000B 10.95 to 11.70 GHz 11.70 to 12.20 GHz 12.25 to 12.75 GHz</td> </tr> </table> | |
| KST-2000A 10-95 to 12.75 GHz | KST-2000B 10.95 to 11.70 GHz 11.70 to 12.20 GHz 12.25 to 12.75 GHz | |
| 2 | Set the down converter to the desired RX operating frequency. | <ol style="list-style-type: none"> 1. See Appendix B.3. 2. There should not be any existing receive system faults. 3. See Appendix B.9. |
| 3 | Using an appropriate power measuring device attached to the IF OUT connector (J4), set the down converter attenuator until the desired downlink gain is attained. | <p>See Appendix B.3.</p> <p>Note: At this point there should be no existing faults.</p> |
| 4 | <ol style="list-style-type: none"> 1. Execute a <Clear Stored Faults> command to clear the fault log, wait a few moments. 2. Execute a <System Fault Status> command to verify. | See Appendix B.9. |
| 5 | <ol style="list-style-type: none"> 1. Remove the AC power from the unit. 2. Remove the 70 MHz (140 MHz) test source. 3. Remove the RX signal source. 4. Remove the coupler/attenuator from the HPA. | |
| 6 | <ol style="list-style-type: none"> 1. The system is ready for final installation to the antenna feed. 2. Perform the rest of the system alignment to applicable international, national, or local regulations. | |

3.2 Initial Setup Redundant System

The following procedures are necessary to laboratory test a redundant KST-2000A/B system for the first time. Refer to the “Communications with Redundant Systems” section in the “M&C Software for Windows™” manual.

| Step | Procedure | Remarks |
|------|---|---|
| 1 | Ensure that the system is set up , except the HPA waveguide switch must be connected to a coupler termination or attenuator. and that the output of the waveguide switches have not been attached to the OMT. | |
| 2 | Remove the PL/3003-1 cable connection between J2, REMOTE, of the KST-2000A/B, unit B, and the RJU-2000. | Unit A determination is made by the PL/8084-1 cable P1 connection. |
| 3 | Apply AC power to KST-2000A/B, unit A. | |
| 4 | <p>Using a KP-10, or a PC equipped with a terminal, or Windows™ based M&C program, ensure communication with unit A via the RJU-2000 Remote connector J6. If communication is established use the address command (<add/AS_x{cr}) to set unit A to address 2.</p> <p>If communication is not established begin troubleshooting. Ensure the proper cabling from the computer to the RJU. Ensure that the communication parameters of the computer match that of the KST-2000A. Ensure the proper mode of communication is being used (RS-485 or RS-422 see page 2-6 of this manual). If necessary connect directly to KST unit A, use RS-232 if the cabling is available. Use a terminal emulator and poll the KST with the command <*/AS_{cr}, this will globally poll the KST for it's address which is the most common problem.</p> <p>Delete If the communication parameters for the system are not known, the Windows□ based M&C system has a utility that will search all combinations of address, baud rate, and parity until communication is established with the system.</p> | <p><u>KST-2000A Default Communication Parameters:</u></p> <p>Address 1 Baud Rate 9600 Parity Even Stop bits 2 Data Length 7 bits</p> <ol style="list-style-type: none"> Using the KP-10 or terminal program, send a miscellaneous command such as EQUIPMENT TYPE (see Appendix B.8). Confirm a response is displayed. The Windows™ based status screen will turn from RED to GRAY when communications with the KST-2000A/B is established. |
| 5 | <ol style="list-style-type: none"> Repeat steps 2, 3 and 4 for Unit B. Ensure that the remote serial address differs from Unit A, typically set to address 3. | |
| 6 | Reconnect the M&C cable between J4 of the RJU-2000 and J2 of KST-2000A/B Unit A, and between J5 of the RJU-2000 and J2 of KST-2000A/B Unit B | |
| 7 | Ensure that serial communications through the RJU-2000, J6 connector, to each KST-2000A/B is still possible (RS-485 or RS-422 only). | The Windows™ based status screen will turn from RED to GRAY when communications with the KST-2000A/B is established. Use option/configuration to select redundancy. |

| Step | Procedure | Remarks |
|------|---|--|
| 8 | Use the RFMC program a KP-10, or terminal emulator, access unit A, enable backup operation in manual mode using the remote commands listed in Appendix B.6. | |
| 9 | <ol style="list-style-type: none"> 1. Using the backup manual operation command to Unit A, place Unit A uplink and downlink online. 2. Ensure unit A reports that both its uplink and downlink are on-line. | See Appendix B.6. |
| 10 | Perform the uplink setup steps listed in Section 3.1.1 | Perform the downlink setup steps listed in Section 3.1.2 |
| 11 | <ol style="list-style-type: none"> 1. Using the backup manual operation command to Unit B, place Unit B uplink and downlink online. 2. Ensure that unit B reports its uplink and downlink are both online. | See Appendix B.6. |
| 12 | Repeat step 14 for Unit B uplink. | Repeat step 14 for Unit B downlink. |
| 13 | Turn the RF output of the up converters of Unit A and B On. | See Appendix B.3. |
| 14 | Execute a Reset Redundancy Fault command, to Units A and B. | See Appendix B.9. |
| 15 | <ol style="list-style-type: none"> 1. At this point there should not be any existing faults. 2. Execute a <Clear Stored Faults> command to clear the fault logs of Unit A and Unit B, wait a few moments. 3. Execute a <System Fault Status> command to Units A and B, and a common equipment stored faults command to verify. | See Appendix B.9. |
| 16 | Remove AC power from Units A and B, remove the 70 MHz (140MHz) test source from RJU-2000 J12, the RX signal source, and coupler/attenuator from the TX switch. | |
| 17 | <ol style="list-style-type: none"> 1. The system is ready for final installation to the antenna feed. 2. Perform the rest of the system alignment to applicable international, national, or local standards. | |

Note: If the KP-10 is used to communicate with the RJU-2000, the user must manually enter the transceiver address. Using the global address will create anomalies.

Note: For a redundant system, each KST-2000A/B must have a different serial address for the M&C through the RJU-2000 to work properly. Also, due to the parallel nature of the M&C interface **only EIA-485, and EIA-422, communications are supported through this device.**

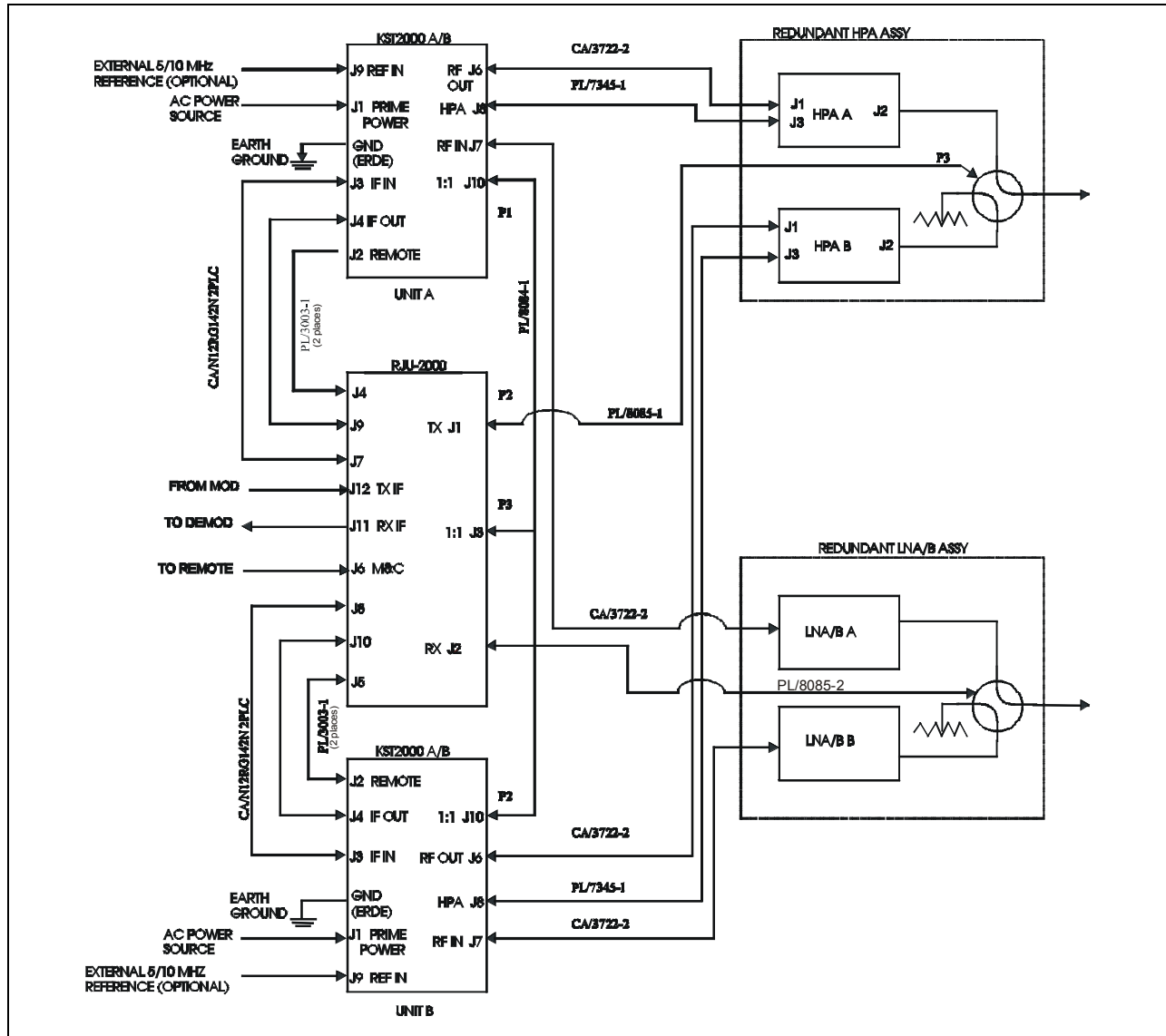

Figure 3-2. 1:1 Redundant System Block Diagram

3.3 Redundant Junction Unit Description

Two KST-2000A/B systems combined with the RJU-2000 form a highly flexible 1:1 redundant transceiver system. There are three modes of operation supported requiring remote intervention only in the case of initial setup. Figure 3-3 shows the front panel of the RJU-2000.

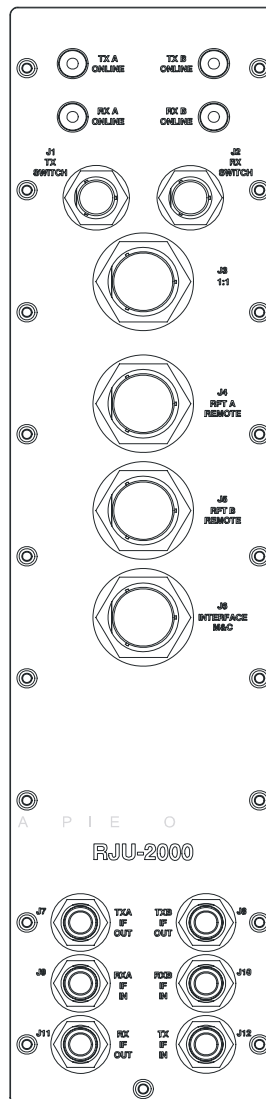

Figure 3-3. RJU-2000 Front Panel

3.3.1 3.3.1 RJU-2000 Description

Refer to Figure 3-4 RJU-2000 block diagram.

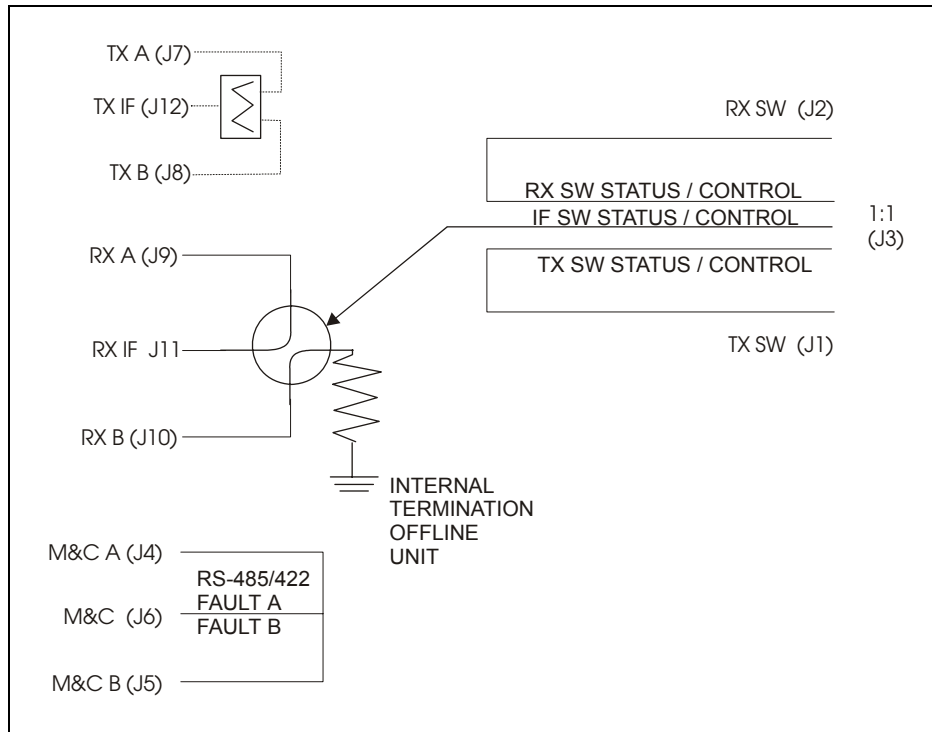

Figure 3-4. RJU-2000 Block Diagram

The RJU-2000 performs several functions vital to correct operation of the redundant KST-2000A/B system. It performs IF splitting of the TX IF input for application to each of the KST-2000A/B up converter inputs. Using an IF splitter on the uplink input maintains an IF input to each up converter, ensuring correct AGC operation in the offline uplink.

The RJU-2000 houses an RX IF transfer switch that is used to select the proper down converter output for application to the RX IF output port (J11). The offline down converter output is internally terminated within the RJU-2000. This switch is not accessible to the user. The redundant system always maintains the position of this switch to correspond to the position of the RX waveguide switch. This ensures that the proper receive IF output signal is always presented to the user at J11.

The RJU-2000 has four weatherproof switch position indicators on its front panel. This enables the operator to quickly determine the online/offline status of each of the system's up and downlinks. The green ON LINE indicators illuminate when the corresponding link is online, and extinguish when a link is offline. These LEDs are powered by diode "OR'd" voltages supplied by the KST-2000A/Bs.

The RJU-2000 combines the individual REMOTE interface of each of the KST-2000A/B systems into a common system M&C connector (J6). Because of the “Parallel” nature of this interface, only EIA-485 (2 wire) and EIA-422 (4 wire), half duplex serial communications are supported. This connector provides a diode “OR’d” power supply to power a KP-10, and routes unit A and B uplink and downlink fault relay outputs to the user. The RJU-2000 performs status signal routing between KST-2000A/B unit A and B and switch position command/indicators to each of the KST-2000A/B and TX RX and IF switches. This is done through the 1:1 connector (J3) and TX (J1) and RX (J2) switch interfaces.

3.4 Connector Descriptions

3.4.1 TX Switch Connector (J1)

The TX switch connector (J1), is a 6-pin, MS style male connector. It routes position commands and indicators from the TX switch to each KST-2000A/B. Refer to Table 3-1 for connector pinout.

Table 3-1. Connector J1 Pinout Description

| Pin | Description |
|-----|---|
| A | Switch position A command, 500 ms +28VDC pulse |
| B | Switch command common |
| C | Switch position B command, 500 ms +28VDC pulse |
| D | Switch position A indicator (D and E connected position A) |
| E | Switch position indicator common |
| F | Switch position B indicator, (E and F connected position B) |

3.4.2 RX Switch Connector (J2)

The RX switch connector (J2) is a 6-pin, MS style male connector. It routes position commands and indicators from the RX waveguide switch to each KST-2000A/B. Refer to Table 3-2 for connector pinout.

Table 3-2. Connector J2 Pinout Description

| Pin | Description |
|-----|---|
| A | Switch position A command, 500 ms +28VDC pulse |
| B | Switch command common |
| C | Switch position B command, 500 ms +28VDC pulse |
| D | Switch position A indicator (D and E connected position A) |
| E | Switch position indicator common |
| F | Switch position B indicator, (E and F connected position B) |

3.4.3 1:1 Interface Connector (J3)

The 1:1 interface connector (J3) is a 26-pin, MS style, female connector. It routes status and commands between KST-2000A/Bs and switches. Refer to Table 3-3 for connector pinout.

Table 3-3. 1:1 Interface Connector J3 Pinout Description

| Pin | Signal | Description |
|-----|-----------|--------------------------------|
| A | TX_SW_CMD | TX switch position A command |
| B | RX_SW_CMD | RX switch position A command |
| C | IF_SW_CMD | IF switch position A command |
| D | A/B_UNIT | GND, indicates unit A |
| E | IF_IND_B | IF switch position B indicator |
| F | IF_IND_A | IF switch position A indicator |
| G | RX_IND_A | RX switch position B indicator |
| H | RX_IND_A | RX switch position A indicator |
| J | TX_IND_B | TX switch position B indicator |
| K | TX_IND_A | TX switch position A indicator |
| L | A_IND_COM | Unit A indicator common |
| M | A_CMD_COM | Unit B command common |
| N | GND | Ground |
| P | TX_SW_CMD | TX switch position B command |
| R | RX_SW_CMD | RX switch position B command |
| S | IF_SW_CMD | IF switch position A command |
| T | A/B_UNIT | GND, indicates unit A |
| U | IF_IND_B | IF switch position B indicator |
| V | IF_IND_A | IF switch position A indicator |
| W | RX_IND_B | RX switch position B indicator |
| X | RX_IND_A | RX switch position A indicator |
| Y | TX_IND_B | TX switch position B indicator |
| Z | TX_IND_A | TX switch position A indicator |
| a | B_IND_COM | Unit A indicator common |
| b | B_CMD_COM | Unit B command common |
| c | GND | Ground |

3.4.4 RFTA Remote Interface Connector (J4)

The RFTA remote interface connector (J4) is a 26-pin, MS style female connector. It routes serial interface signals, KP-10 power, and uplink and downlink fault information from Unit A J2 remote to RJU-2000 J6, interface M&C connector. Refer to Table 3-4 for connector pinout.

Table 3-4. RFTA Remote Interface Connector J4 Pinout Description

| Pin | Signal | Description |
|-----|------------|---|
| A | -TX/RX -RX | -EIA-485 TX/RX or -EIA-422 RX |
| B | -TX/RX -TX | -EIA-485 TX/RX or -EIA-422 TX |
| C | +TX/RX +RX | +EIA-485 TX/RX or +EIA-422 RX |
| D | +TX/RX +TX | +EIA-485 TX/RX or +EIA-422 TX |
| E | N/C | No connection |
| F | N/C | No connection |
| G | N/C | No connection |
| H | N/C | No connection |
| J | GND | Ground |
| K | N/C | No connection |
| L | GND | Ground |
| M | RESET | Reset, (momentary low resets system) |
| N | GND | Ground |
| P | N/C | No connection |
| R | GND | Ground |
| S | +12V | +12VDC (KP-10 power supply output) |
| T | 2/4 wire | EIA-485 (open)/EIA-422 (ground) operation |
| U | UL_FLT_NC | Uplink fault relay, closed = fault |
| V | UL_FLT_COM | Uplink fault relay, common |
| W | UL_FLT_NO | Uplink fault relay open = fault |
| X | DL_FLT_NC | Downlink fault relay, closed = fault |
| Y | DL_FLT_COM | Downlink fault relay common |
| Z | DL_FLT_NO | Downlink fault relay, open = fault |
| a | N/C | No connection |
| b | N/C | No connection |
| c | N/C | No connection |

3.4.5 RFTB Remote Interface Connector (J5)

The RFTB remote interface connector (J5) is a 26-pin, MS style female connector. It routes serial interface signals, KP-10 power, and uplink and downlink fault information from Unit B J2 remote to RJU-2000 J6, interface M&C connector. Refer to Table 3-5 for connector pinout.

Table 3-5. RFTB Remote Interface Connector J5 Pinout Description

| Pin | Signal | Description |
|-----|----------------|---|
| A | -TX/RX -RX | -EIA-485 TX/RX or -EIA-422 RX |
| B | -TX/RX -TX | -EIA-485 TX/RX or -EIA-422 TX |
| C | +TX/RX +RX | +EIA-485 TX/RX or +EIA-422 RX |
| D | +TX/RX +TX | +EIA-485 TX/RX or +EIA-422 TX |
| E | N/C | No connection |
| F | N/C | No connection |
| G | N/C | No connection |
| H | N/C | No connection |
| J | GND | Ground |
| K | N/C | No connection |
| L | GND | Ground |
| M | RESET | Reset, (momentary low resets system) |
| N | GND | Ground |
| P | N/C | No connection |
| R | GND | Ground |
| S | +12V | +12VDC (KP-10 power supply output) |
| T | 2/4 wire | EIA-485 (open)/EIA-422 (ground) operation |
| U | UL_FLT_NC | Uplink fault relay, closed = fault |
| V | UL_FLT_CO M | Uplink fault relay, common |
| W | UL_FLT_NO | Uplink fault relay open = fault |
| X | DL_FLT_NC | Downlink fault relay, closed = fault |
| Y | DL_FLT_CO M | Downlink fault relay common |
| Z | DL_FLT_NO | Downlink fault relay, open = fault |
| a | N/C | No connection |
| b | N/C | No connection |
| c | N/C | No connection |

3.4.6 Interface M&C Connector (J6)

The interface M&C connector (J6) is a 26-pin, MS style, female connector. It provides the system M&C interface with EIA-485 or EIA-422 control of the redundant KST-2000A/B, provides diode OR'd +12V power for a KP-10, and routes uplink and downlink fault relay contacts from each KST-2000A/B to the remote M&C system. Refer to Table 3-6 for connector pinout.

Table 3-6. Interface M&C Connector J6 Pinout Description

| Pin | Signal | Description |
|-----|-----------------|---|
| A | -TX/RX -RX | -EIA-485 TX/RX or -EIA-422 RX |
| B | -TX/RX -TX | -EIA-485 TX/RX or -EIA-422 TX |
| C | +TX/RX +RX | +EIA-485 TX/RX or +EIA-422 RX |
| D | +TX/RX +TX | +EIA-485 TX/RX or +EIA-422 TX |
| E | ULA_FLT_NC | Uplink A fault relay, closed = fault |
| F | ULA_FLT_CO M | Uplink A fault relay common |
| G | ULA_FLT_NO | Uplink A fault relay, open = fault |
| H | N/C | No connection |
| J | GND | Ground |
| K | N/C | No connection |
| L | GND | Ground |
| M | RESET | Reset, (momentary low resets system) |
| N | GND | Ground |
| P | N/C | No connection |
| R | GND | Ground |
| S | +12V | +12VDC (KP-10 power supply output) |
| T | 2/4 wire | EIA-485 (open)/EIA-422 (ground) operation |
| U | ULB_FLT_NC | Uplink B fault relay, closed = fault |
| V | ULB_FLT_CO M | Uplink B fault relay, common |
| W | ULB_FLT_NO | Uplink B fault relay open = fault |
| X | DLB_FLT_NC | Downlink B fault relay, closed = fault |
| Y | DLB_FLT_CO M | Downlink B fault relay common |
| Z | DLB_FLT_NO | Downlink B fault relay, open = fault |
| a | DLA_FLT_NC | Downlink A fault relay, closed = fault |
| b | DLA_FLT_CO M | Downlink A fault relay common |
| c | DLA_FLT_NO | Downlink A fault relay, open = fault |

3.4.7 Other Connectors

| | |
|----------------------------------|--|
| TXA IF OUT Connector (J7) | The TXA IF OUT connector (J7), is a type N, female connector used to route the transmit IF signal (70 or 140 MHz) to KST-2000A/B Unit A, IF INPUT. From the system TX IF IN port (J12). Nominal impedance 50Ω, unbalanced. |
| TXB IF OUT Connector (J8) | The TXB IF OUT connector (J8), is a type N, female connector used to route the transmit IF signal (70 or 140 MHz) to KST-2000A/B Unit B, IF INPUT. From the system TX IF IN port (J12). Nominal impedance is 50Ω, unbalanced. |
| RXA IF IN Connector (J9) | The RXA IF IN connector (J9) is a type N, female connector used to route the received IF signal (70 or 140 MHz) from KST-2000A/B, Unit A IF OUTPUT to the system RX IF OUT (J11). Nominal impedance is 50Ω, unbalanced. |
| RXB IF IN Connector (J10) | The RXB IF IN connector (J10) is a type N, female connector used to route the received IF signal (70 or 140 MHz) from KST-2000A/B, Unit B IF OUTPUT to the system RX IF OUT (J11). Nominal impedance 50Ω, unbalanced. |
| RX IF OUT Connector (J11) | The RX IF OUT connector (J11), is a type N female connector used to connect the RX IF signal (70 or 140 MHz) from the online KST-2000A/B down converter to the modem. Nominal impedance is 50Ω, unbalanced. |
| TX IF IN Connector (J12) | The TX IF IN connector (J12), is a type N, female connector used to route the 70 or 140 MHz IF signal from a modem, through an IF splitter to each of the KST-2000A/B IF input of the up converters. Nominal impedance is 50Ω, unbalanced. |

3.5 Indicators Description

| | |
|------------------------------|---|
| TX A Online Indicator | The TX A online indicator is a weatherproof, green LED that illuminates when uplink A is online, and extinguishes when uplink A is offline. |
| TX B Online Indicator | The TX B online indicator is a weatherproof, green LED that illuminates when uplink B is online, and extinguishes when uplink B is offline. |
| RX A Online Indicator | RX A online indicator is a weatherproof, green LED that illuminates when downlink A is online, and extinguishes when downlink A is offline. |
| RX B Online Indicator | The RX B online indicator is a weatherproof, green LED that illuminates when downlink B is online, and extinguishes when downlink B is offline. |

3.6 1:1 Redundant KST-2000A/B System Operation

This section details the 1:1 redundant KST-2000A/B system operation. **Error! Reference source not found.** shows a typical 1:1 system block diagram, comprising:

- Two KST-2000A/B transceiver systems
- One RJU-2000 redundancy junction unit
- Associated cables and hardware

The 1:1 redundant system is a highly flexible signal protection system with three user-selectable modes of operation.

The key components that make up the redundancy system are the:

- RJU-2000
- 1:1 interconnect cable
- TX and RX waveguide switches

The RJU-2000 provides TX and RX IF signal routing functions, and command and status signal routing throughout the system.

The 1:1 interconnect cable routes status and control signals between the KST-2000A/Bs and the TX/RX switches through the RJU-2000.



This cable also designates the A Unit and B Unit KST-2000A/B, so strict attention must be paid to how this is connected into the system. The A Unit connector of this cable (P1) must be connected to the A Unit KST-2000A/B, otherwise the system will not operate properly.

Figure 3-9 shows a redundant KST-2000A/B, and the location of the A Unit. The same is true for the interconnecting cables between the redundant HPA assembly and redundant LNA/B assembly.

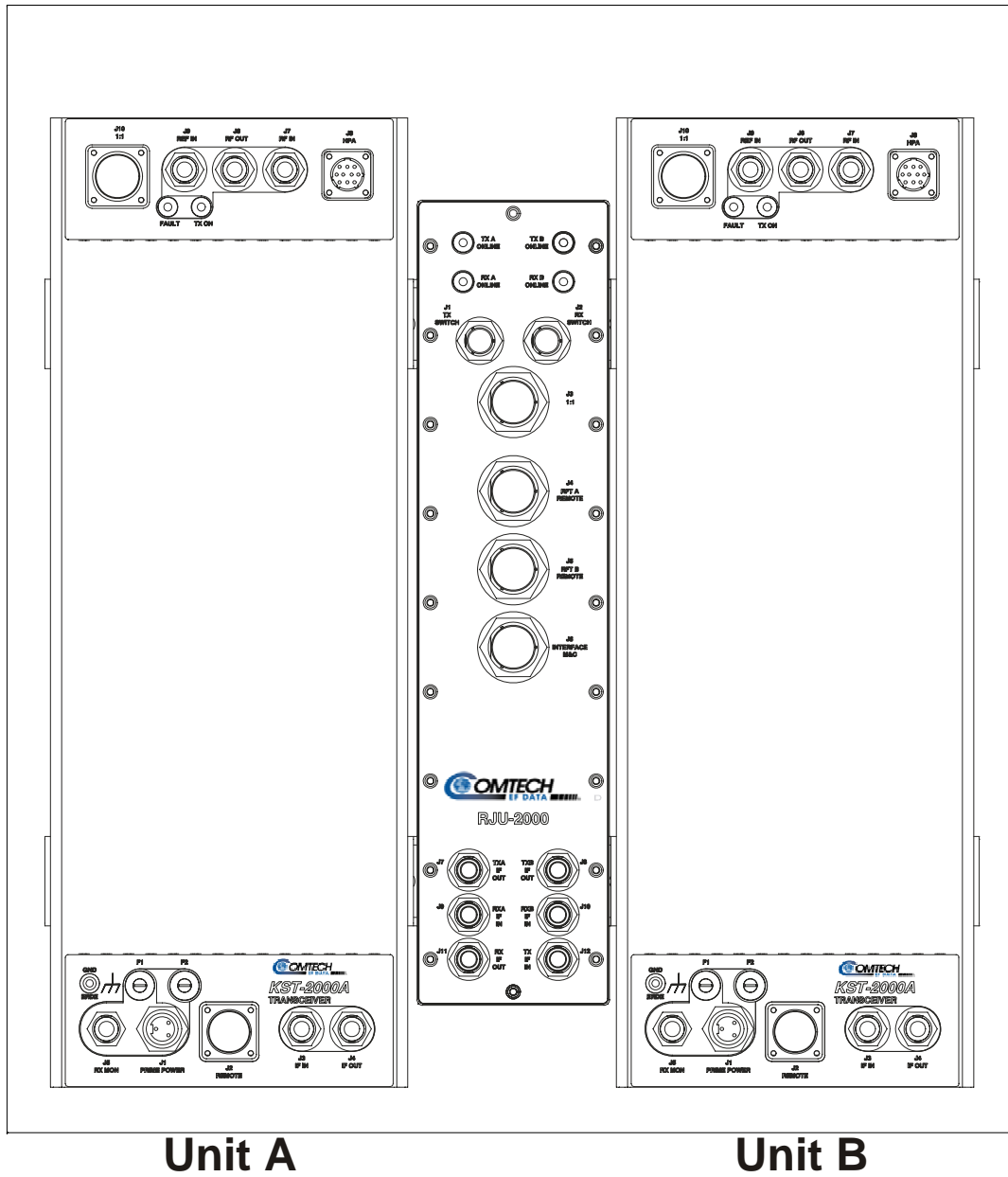

Figure 3-5. Redundant KST-2000A/B System Showing Units A and B Designation

Figure 3-10 shows the positions of the A side on the redundant HPA.

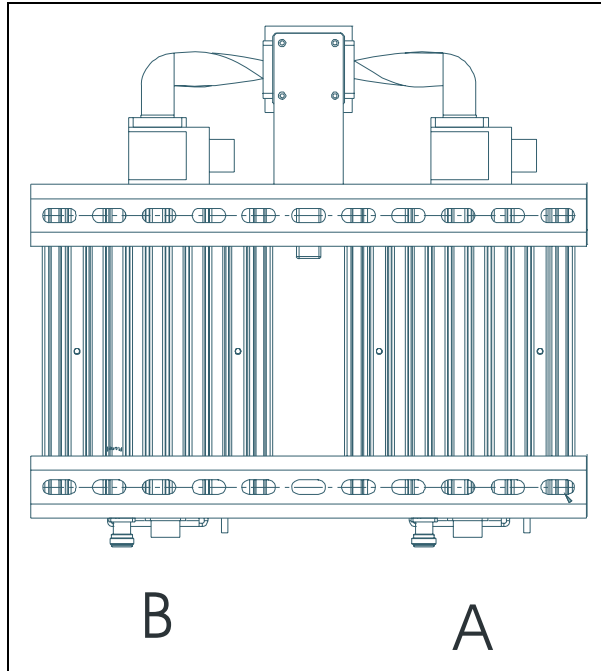

Figure 3-6. Redundant HPA Assembly

Figure 3-11 shows the position of the A side on the redundant LNA/B assembly.

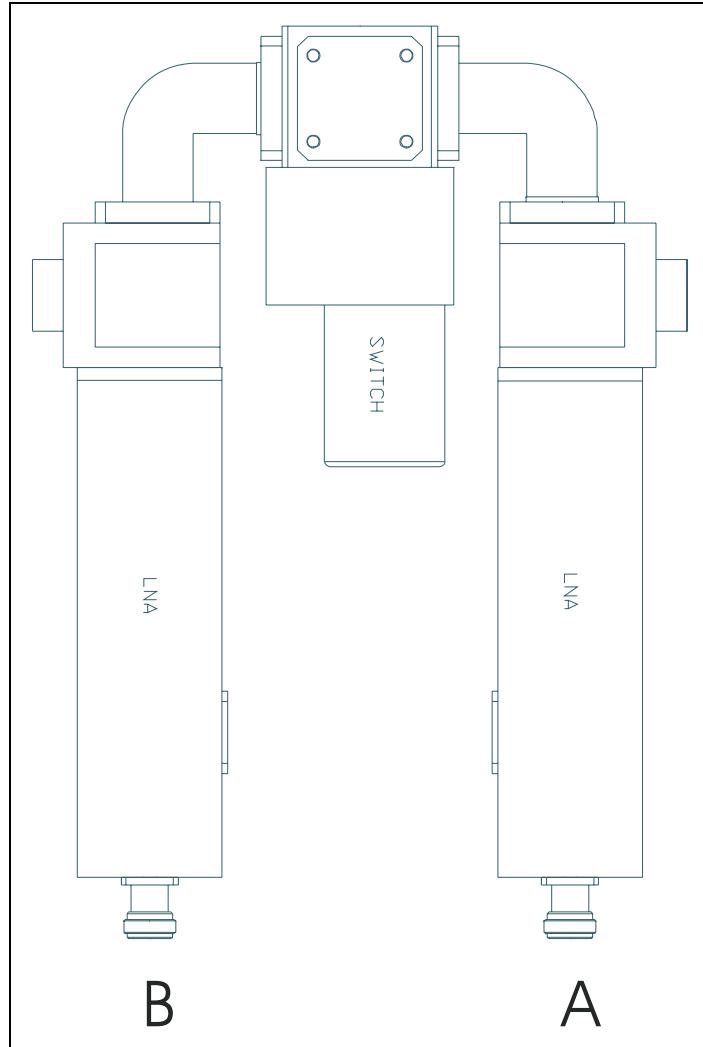

Figure 3-7. Redundant LNA/B Assembly

Each KST-2000A/B has built-in redundancy logic and the capability to control a TX, RX, and IF switch. The 1:1 interconnect cable designates an A Unit and a B Unit. An A Unit will become the primary interface for remote backup configuration commands. In addition, the A Unit will control the A position of the TX, RX, and IF switches; likewise the B Unit controls the B position of the TX, RX, and IF switches.

The A Unit will pass operating mode and configuration information to the B Unit. The B Unit will accept these commands through the 1:1 interface only. Fault information for each unit is also passed to the other through this interface, so each KST-2000A/B is aware of the fault status of the other. Uplink and downlink online assertions are made through this interface also, thereby informing the other KST-2000A/B of which unit is currently online. Whenever there is contention between the units, unit A always prevails. This can happen when the A Unit uplink is online, and B Unit downlink is online, and automatic dependent mode is enabled. In this mode, the entire up and down link of the system must pass through a single KST-2000A/B; so, the A Unit will place its downlink online.

The user-selectable operating modes of the redundant KST-2000A/B are:

- Manual mode
- Automatic, independent switching
- Automatic, chain switch (dependent)

In order to enable any backup operating mode, a KP-10, or a PC running a terminal or Windows™ based M&C system is required. The user will not be able to enable backup operation unless the RJU-2000 and two KST-2000A/B's are connected via the 1:1 interconnect cable. The backup enable and backup mode of operation can only be selected through the A Unit. Refer to Appendix B.6 for an explanation of these commands. Once these commands are accepted by the A Unit, the B Unit will also assume this configuration automatically.

The default setup after backup mode has been enabled will be manual mode and the uplink and downlink switch position indicators will report the actual position of the TX and RX switch.

In manual mode, the operator has full control over the uplink and downlink switch positions. They can be controlled through the Interface M&C (J6) with serial commands, or manually by removing the weather-tight covers on the waveguide switches, and manually rotating the switch. If the RX waveguide switch position is changed in this manner, the RX IF switch will automatically change its position to match. This ensures that the entire downlink selected is the one that is output by the system. If remote commands are issued to place an uplink or downlink online, the command is issued to the KST-2000A/B unit that will be assuming control.

For example: to place Unit B uplink online, the remote backup manual operation command to Unit B's uplink will be issued. Refer to Appendix B.6.

In the manual mode, as well as any other backup enabled operating mode, the switch position indicators on the RJU-2000 will indicate which uplink and downlink is online by illuminating an appropriate LED indicator. Generally, after the redundant KST-2000A/B system has been set up for its final operating condition, automatic system operation/protection mode is enabled.

In automatic mode, remote backup manual operation commands will be ignored by the system, and manual interference of the TX or RX waveguide switch position will be overridden by the system.

Two types of automatic protection are supported by the KST-2000A/B:

- *Automatic, independent switching* – In this automatic protection mode, each KST-2000A/B will monitor uplink and downlink fault inputs from the other KST-2000A/B. Independent switching of the uplinks and downlinks can occur.

For example: A fault in an online uplink will cause the the offline KST-2000A/B to place its uplink online by transferring the TX waveguide switch to its position. In this scenario, the downlink path remains unchanged until a fault occurs in the online downlink. If a standby link is faulted, no switching will occur until either the A or B link fault clears.

- *Automatic, chain switch (dependent switching) mode* – Operation in this mode is similar to automatic independent operation, except that when a fault occurs both the up and down link of the faulted KST-2000A/B are transferred offline.

Possible Redundancy Errors:

In the automatic modes, if the 1:1 interface cable is removed from one of the KST-2000A/Bs, the remaining attached KST-2000A/B will assume control of both the uplink and downlink. Both KST-2000A/Bs will report a 1:1 cable fault.

The KST-2000A/B in backup enabled mode will report a TX, RX, or IF switch fault if the corresponding cable is removed from a switch, or if the position indicators are malfunctioning.

Both of these errors require that either:

- **Backup mode be disabled, and then re-enabled.**
Reference: Refer to Appendix B.6 after the fault is cleared, or
- **A reset redundancy faults command is issued to each unit.**
Reference: Refer to Appendix B.9.

3.7 Reference Oscillator

The reference oscillator assembly (Figure 3-12) consists of a high stability, 10 MHz, Oven Controlled, Voltage Controlled, Crystal Oscillator (OCVCXO), a 72 MHz oscillator, and a micro-controller.

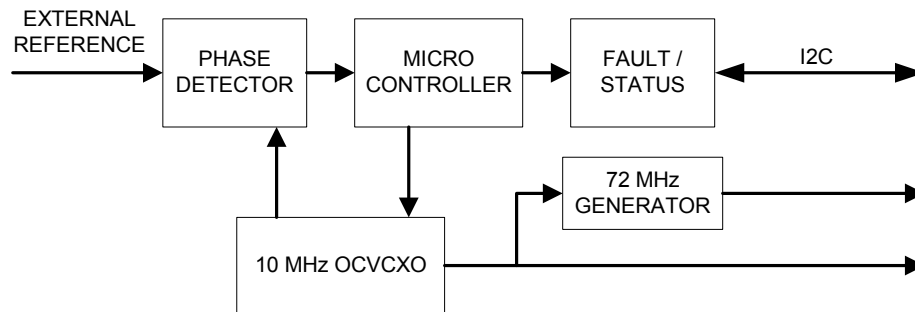

Figure 3-8. Reference Oscillator

The reference oscillator assembly can accept an external 5 or 10 MHz input signal $\leq +6$ dBm. The reference oscillator has an onboard phase detector which is used to frequency lock the 10 MHz oscillator to the external reference. A bias voltage output from the phase detector is read into the microcontroller via an A to D converter. The microcontroller interprets this bias voltage and generates a tuning voltage output proportional to the phase/frequency difference between the onboard oscillator and the external reference input. This output is applied to the tuning voltage input on the OCVCXO to shift its operating frequency to maintain frequency lock with the external input.

The 10 MHz OCVCXO is a high stability, low phase noise, crystal oscillator. It has a tuning voltage input which can be used to fine tune the oscillator frequency. When the KST-2000A/B is operating without an external 5 or 10 MHz input, the M&C generates a bias voltage which can be changed remotely. That sets the oscillator frequency.

When an external reference is applied, the KST-2000A/B will generate a bias voltage of sufficient level to keep the 10 MHz reference frequency locked to the external input. The 10 MHz output is amplified and distributed to the down converter, where it is the reference for the DROs. It also serves as the reference frequency for the 72 MHz oscillator.

The 72 MHz VCXO is phase locked to the 10 MHz reference. The 72 MHz output of the VCXO is amplified and distributed throughout the KST-2000A/B to provide a reference frequency for the up converter and portions of the down converter.

The microcontroller performs several operations on the reference assembly.

- It monitors the external reference status, and if an external input is detected, will try to frequency-lock the 10 MHz oscillator.
- It monitors the 10 MHz oscillator oven current to determine when the oscillator is warmed enough to provide a stable output.
- It sends control words to the 72 MHz PLL.
- It gathers and reports fault and status information to the KST-2000A/B M&C assembly.

3.8 Monitor and Control (M&C)

The Monitor and Control (M&C) monitors the KST-2000A/B and provides configuration updates to the up converter, down converter, and HPA when necessary. Refer to Figure 3-13.

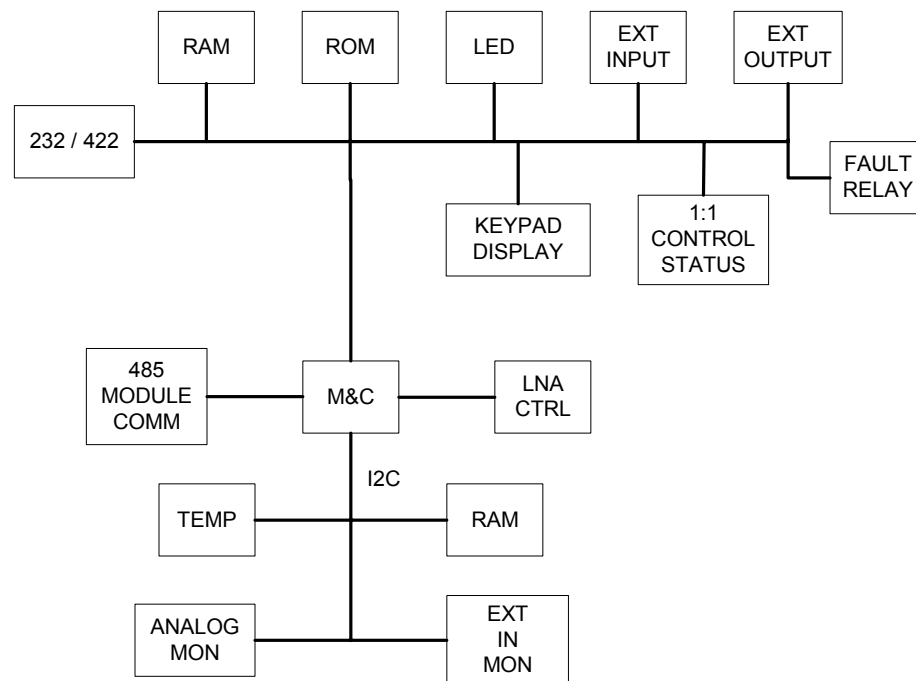

Figure 3-9. Monitor and Control (M&C) Block Diagram

The KST-2000A/B configuration parameters are maintained on battery locked RAM, which provides recovery after power down.

The M&C functions include extensive fault and status reporting, as well as 1:1 redundancy logic. All KST-2000A/B functions are accessible through the remote communications interface.

The M&C is composed of the following sections:

- Microcontroller/UART
- Fault relays
- LNA power control
- Intermodule COMM interface
- D to A and A to D converters
- ROM/RAM
- 1:1 redundancy logic
- External I/O interface

The microcontroller is a Dallas 80C310 operating at 16 MHz. The microcontroller contains 256 bytes of internal RAM. The external ROM is 29F040 (512 kbytes). The battery backed RAM is 8 kbytes in size.

The non-volatile RAM allows the KST-2000A/B to retain configuration information without prime power for 1 year.

The UART supports serial asynchronous communication (remote port) with a maximum data rate of 19200 bit/s. The communications type can be EIA-232, EIA-485 (2-wire), or EIA-422 (4-wire) half duplex.

The DAC supplies a voltage that fine tunes the reference oscillator operating frequency. The ADC monitors the internal power supply voltages, as well as external temperature and analog inputs from SSPAs and TWTAs.

The three fault relay outputs are failsafe. They will indicate a fault in the event of a power outage. The three relays are uplink fault, downlink fault, and summary fault.

The M&C has built-in redundancy logic. It reads switch position and external status information from the waveguide switches and the other KST-2000A/B. It provides control information based on these inputs.

The M&C has a step-up power supply that is enabled during switch transfers. The supply generates +28VDC at more than 1 amp to control the waveguide switches. After the switch transfer is complete, the +28VDC supply is shut down. The M&C has a switching regulator that can generate +15VDC at 200 mA to power an external LNA/B. This voltage can be enabled or disabled via the remote interface. The M&C monitors the LNA current and generates a fault if the LNA/B current draw increases or decreases excessively.

The M&C can generate external discrete commands for operation of more than 25W SSPAs and TWTAs. The M&C also monitors alarm and status outputs from these devices.

The M&C communicates status and control information to the up converter, down converter and 25 W and lower SSPAs via a high speed EIA-485 interface.

3.8.1 Up Converter Description

The up converter accepts a 70 MHz (140 MHz) IF input signal and translates it to an output frequency in the range of 13.750 to 14.500 GHz. The up converter consists of two modules: the IF to S-Band module and the S- to Ku-Band module.

The IF to S-Band module translates the 70 MHz (140 MHz) IF input to an output frequency in the range of 2,330 to 3,080 MHz. Refer to Figure 3-14 for a block diagram of the IF to S-Band module.

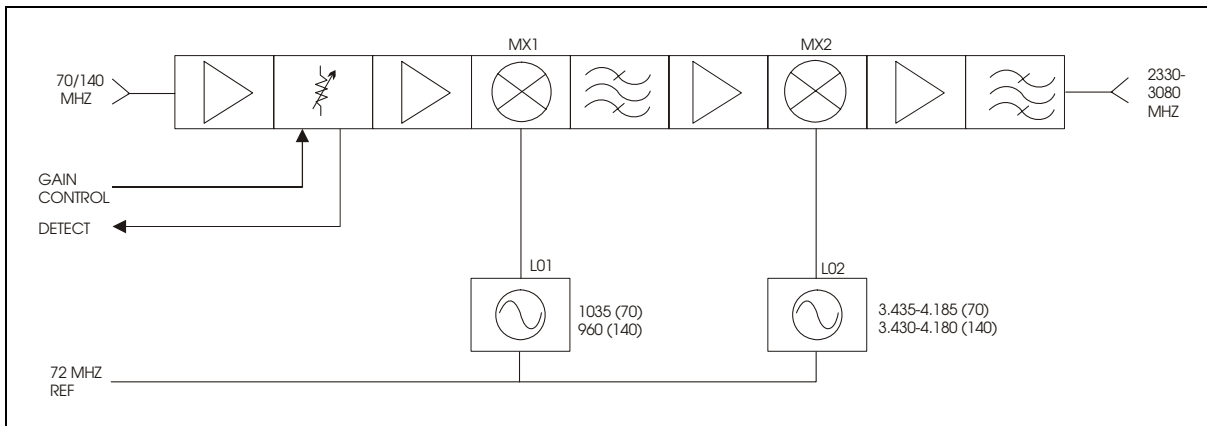

Figure 3-10. IF to S-Band Converter Module Block Diagram

The 70 MHz (140 MHz) IF input is first amplified, and then applied to an electronically variable attenuator. This attenuator is controlled via the local M&C to provide calibrated 1dB attenuation steps over a 20 dB attenuation range. The signal is then amplified and heterodyned with a fixed frequency LO1. The desired sideband of this process is selected via bandpass filtering and applied to the second up conversion stage MX2. LO2 is a low noise synthesized source, whose output covers 750 MHz in 1 MHz steps. The output of the second up conversion stage is a signal in the 2330 to 3080 MHz frequency range. This signal is applied to the input of the S- to Ku-Band module.

This module is slightly different for the 70 MHz and 140 MHz IF input options. As shown in Figure 3-14, the LOs are tuned to different frequencies and filtering is different.

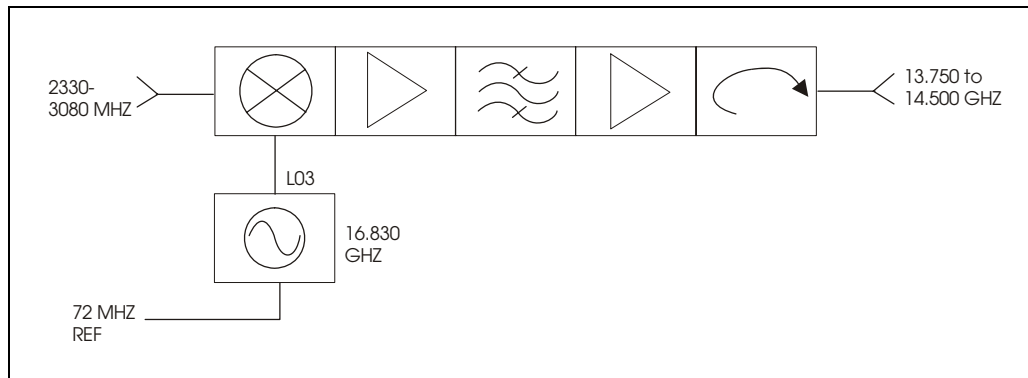

Figure 3-11. S to Ku-Band Up Converter Module

The S- to Ku-Band up converter module (Figure 3-11) performs block up conversion of the 2330 to 3080 MHz signal input to an output in the range of 13.750 to 14.500 GHz. This is done by mixing the IF input with a fixed frequency Dielectric Resonator Oscillator (DRO), operating at 16.830 GHz. The correct sideband of this process is amplified and filtered before being applied to the isolated output of the module.

3.9 Ku- to L-Band Converter Description (KST-2000A)

The Ku- to L-Band converter (Figure 3-16) accepts an RF signal in the range of 10.95 to 12.75 GHz, and translates it to an output frequency in the range of 950 to 1700 MHz. It does this by pre-selecting the RF frequency range and block converting using one of three phase locked DROs.

The DROs operate at 10.0, 10.75, and 11.3 GHz, and are automatically selected when the down converter is tuned. The down converter can supply +15V through its RF input connector to power an external LNA. The LNA power can be turned on or off via remote M&C command. The down converter also provides an additional L-Band output for signal monitoring purposes.

This module is not in-place for the KST-2000B as block down conversion is performed by the LNB.

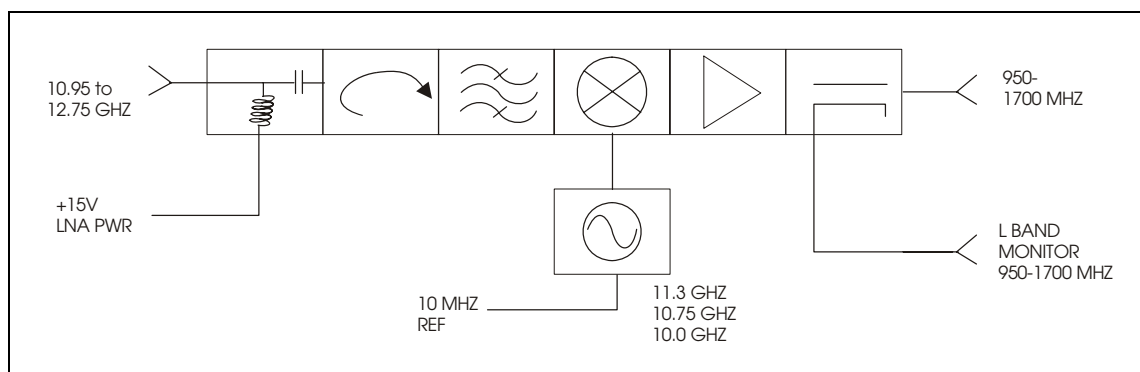

Figure 3-12. Ku to L-Band Down Converter Module Block Diagram

3.10 L-Band to IF Down Converter Description (KST-2000A/B)

The L-Band to IF down converter (Figure 3-17) accepts an RF input in the frequency range of 950 to 1700 MHz and translates it to an output of 70 (140) MHz. The RF input to this module can be supplied by the Ku to L-Band down converter housed within the KST-2000A, or from an externally mounted Low Noise Block down converter (LNB) in the KST-2000B version. Interface circuitry is added to this module for the KST-2000B in addition to an L-Band monitor coupler as shown by the dotted lines in Figure 3-13.

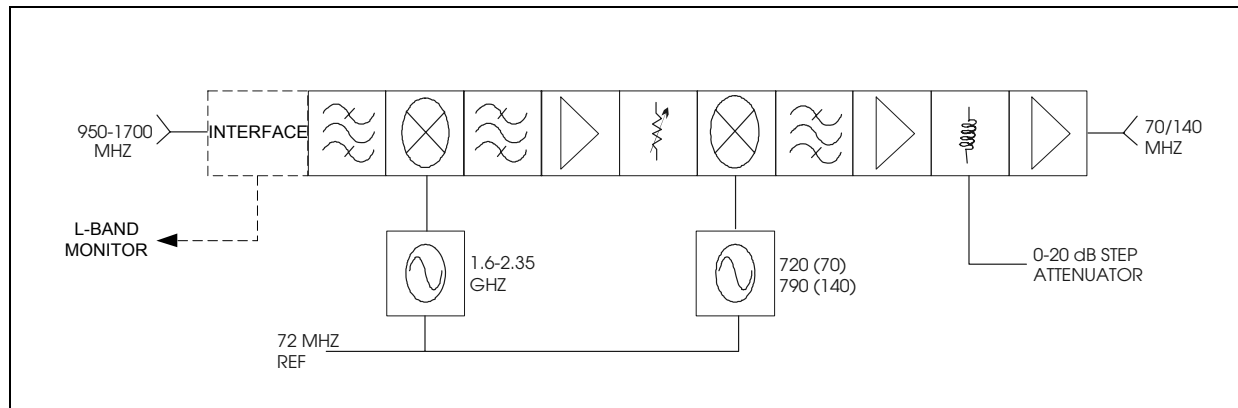

Figure 3-13. L-Band to IF Down Converter Block Diagram

The 950 to 1700 MHz input is first pre-selected and then heterodyned with a local oscillator in the range of 1.6 to 2.35 GHz to generate the first IF signal of 650 MHz. The 650 MHz signal is then mixed with 790 or 720 MHz to generate the 70 or 140 MHz output. The IF output frequency of the second down conversion stage is then amplified and applied to a 0 to 20 dB step attenuator with 1 dB steps. The overall L-Band down converter tunes in a frequency step-size of 1 MHz across the 950 to 1700 MHz band.

This module is slightly different for the 70 and 140 MHz options.

3.11 Automatic Gain Control (AGC)

Note: AGC function only available with SSPAs of $\leq 25\text{W}$.

The KST-2000A/B incorporates a closed-loop Automatic Gain Control (AGC) function that maintains the system gain, as measured from the TX IF input to the Ku-Band output of the Comtech EF Data supplied SSPA, at the user's preset value despite the effects of aging, operating temperature, or cabling loss. This is not a Automatic Level Control (ALC) function, but a true AGC that maintains the gain of the system constant independent of input and output absolute levels. This is important to multicarrier operation, when individual carriers turn On/Off and the level of the remaining carriers must remain unaffected. This function is designed to operate with only Comtech EF Data SSPAs that incorporate a calibrated output detector. The transceiver can be set to operate in either the AGC, non-AGC, or MANUAL gain mode.

3.11.1 Operation

The AGC function is implemented by using two calibrated RF detectors.

- The first detector monitors the TX input (70 or 140 MHz; amplitude range of –25 to –45 dBm). The DC voltage from the detector is converted to a digital word in an A/D converter and read by the main processor.
- The second detector monitors the output signal of the SSPA. This detector is calibrated for five frequencies over the output frequency range. Additionally, the second detector calibration covers output power from the saturation point of the amplifier down to 30 dB (approximately) below saturation.

The calibration data is stored in a non-volatile memory within each SSPA making all SSPAs interchangeable without loss of system gain accuracy. The estimate of output power corresponds to the detector voltage linearly interpolated between nearby frequency and power steps stored in memory. The main processor reads the estimated output power from the SSPA and computes an error function as follows:

$$\text{Gain Error} = \text{SSPA Output Power} - \text{Input Power} - \text{Gain_Max} + \text{UCA}$$

Where Gain_Max is the maximum specified gain of the entire transceiver (converter unit plus SSPA) and UCA is the value of the up converter attenuator and is set by:

$$\langle \text{add/UCA_xx.x (Appendix B)} \rangle$$

The main processor processes this data and generates an analog voltage that adjusts the up converter attenuator to drive the error function to zero.

When the uplink AGC is enabled (<add/UAGC_ON) the display value of UCA will include a decimal point. Attenuation is adjustable over a range of 0 to 20 dB in 1 dB steps. When the uplink AGC is disabled (<add/UAGC_OFF) the displayed value of UCA does not include the decimal point.

3.11.2 Fault and Error Response

Table 3-7 shows how the AGC system reacts to power outages, system faults and operation outside the specified limits.

Table 3-7. AGC Fault and Error Response

| Problem | Response/Notes |
|---|--|
| If the transceiver prime power fails | The UCA value is effect prior to the failure is restored on power up. |
| If the input signal (70 or 140 MHz) is removed or is set to ≤ -45 dBm. | <ol style="list-style-type: none"> 1. The internal Up Converter attenuator is set to its maximum value (minimum gap). 2. The value of UCA is not affected. 3. The output power will slowly increase for several seconds until the gain error reaches zero, when the input signal is reapplied. |
| If the user enters a value of UCA that is low for a set input level. | <ol style="list-style-type: none"> 1. The SSPA will be driven into saturation and the value of UCA will automatically increase (Gain decreased) in steps of 1 dB until the SSPA output power is below saturation. 2. The new (increased) value of UCA is displayed at the user's interface. Even if the input power is reduced, the new value of UCA will remain fixed. |
| If the input power is increased, such that the SSPA is driven into saturation. | <ol style="list-style-type: none"> 1. The value of UCA is increased (Gain decreased) in steps of 1 dB until the SSPA is below saturation. 2. The new value of UCA is displayed at the user's interface. Even if the input power is reduced, the new value of UCA will remain fixed. |
| Loop fault occurs when the Gain Error is nonzero for >5 out 255 iterations of the processor control loop. | <ol style="list-style-type: none"> 1. A top level AGS_Fault is reported. 2. Excessive cable loss between the converter unit and the SSPA can cause this condition. 3. If the AGC is enabled and the RF is commanded Off (<add/RF_OFF), this fault is registered. |
| INSUFFICIENT INPUT POWER fault is generated when the IF input power transitions from normal power to low power (< -45 dBm). | Under this condition, a top level AGS_fault is reported and the internal up converter attenuator is set to its maximum value (minimum RF output). The value of UCA is not affected. When the input signal increases above -45 dBm, the output power will slowly increase for several seconds until the gain error reaches zero. |
| EXCESSIVE INPUT POWER fault is generated when the IF input power transitions from normal power to high power (> -25 dBm). | Under this condition, a top level AGS_Fault is reported. If the combination of the input power and the up converter attenuator is such that the SSPA is driven into saturation, the value of the UCA will automatically increase in steps of 1 dB until the SSPA output power is below saturation. The new value of UCA is displayed at the user's interface. Even if the input power is reduced, the new values of UCA will remain fixed. |

The LOOP, INSUFFICIENT INPUT POWER, and EXCESSIVE INPUT POWER faults can be displayed by issuing the AGC current faults command (<add/AGS_). The allowed ranges of IF input power and UCA settings are limited by the SSPA saturation and detector range to the shaded area defined in Figure 3-18.

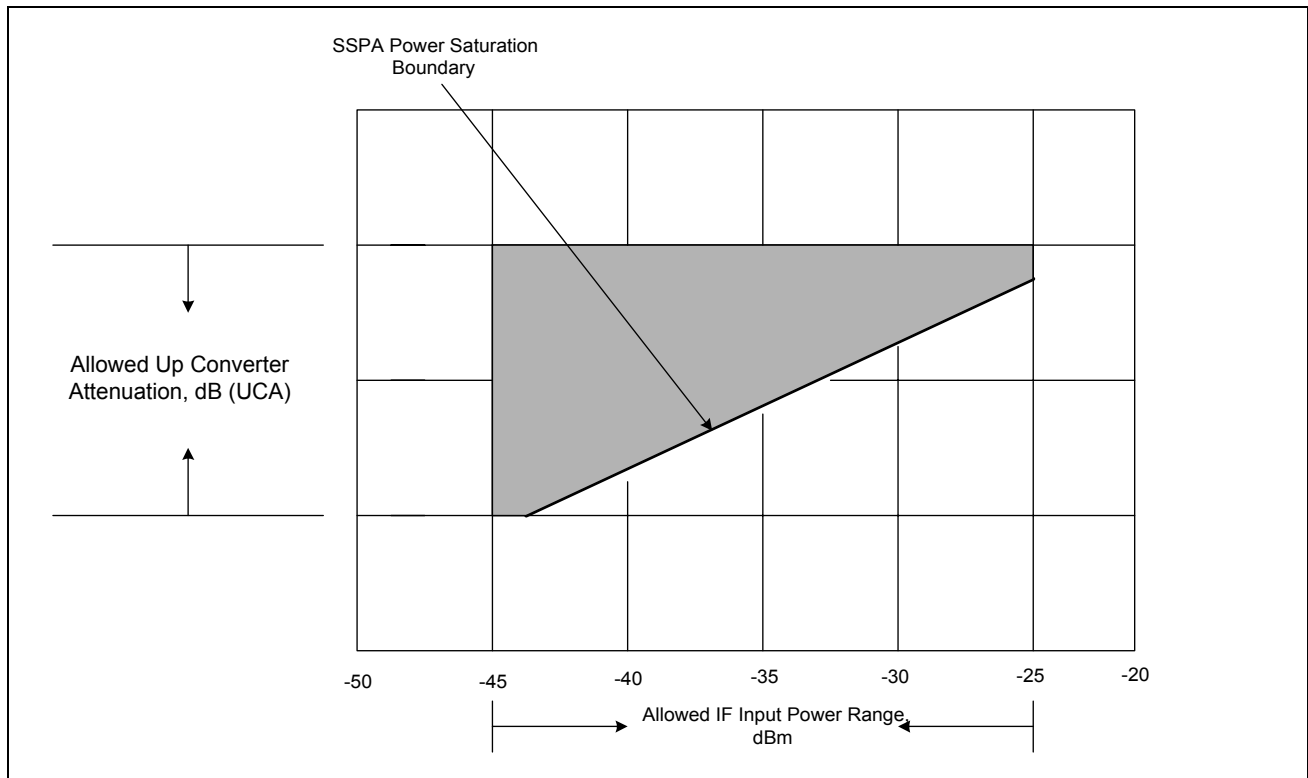

Figure 3-14. AGC Operating Region

3.11.3 Manual Gain Operation

With AGC disabled, the closed loop control of the uplink path is disabled. The SSPA saturation, INSUFFICIENT INPUT POWER, EXCESSIVE INPUT POWER, and LOOP faults are not monitored or reported as faults. The status of the AGS fault is displayed as OK. In this mode, the system gain is not accurately defined as in the AGC mode, because the accuracy of the up converter's programmable attenuator and the static gains of the up-link amplifiers determine the gain.

When this mode is selected, UCA will display as an integer (with no decimal point), and the allowed range of the UCA is 0 to 55 dB in 1 dB steps. The accuracy of the attenuator is not guaranteed and degrades at high values.

Chapter 4. FAULT INDICATION AND ISOLATION

This section describes fault indication and isolation methods for the KST-2000A/B system. Routine maintenance for the system consists only of assuring air flow for cooling of the units, particularly assuring that debris does not prohibit proper fan function on HPAs so equipped. A system fault is indicated in three ways:

- An external LED
- Form C relay contacts
- The remote M&C control

4.1 Fault Indication

The KST-2000A/B converter unit has two external LED indicators as shown pictorially in Figure 2-1. The TX ON indicator is GREEN when illuminated, and the FAULT indicator is RED.

When prime power is applied to the KST-2000A/B and the HPA is transmitting power, the TX ON indicator is a steady GREEN. The indicator flashes when prime power is applied but the HPA is not transmitting. The FAULT indicator is a steady RED when any fault is detected by the internal M&C processor.

The REMOTE connector (J2) has pins assigned (see Chapter 2, section 2.2 for pin assignments) for the contacts on two form C relays, one for the uplink and one for the downlink. Normally open contacts close and normally closed contacts open when there is a fault in any part of the uplink or downlink. Fault isolation requires the use of the remote M&C as described in section 4.2.

4.2 Fault Isolation

System faults are reported on the Fault Log screen in the Windows™ based remote M&C software. (Alternatively, they may be viewed in the terminal mode as shown in Appendix B). Table 4-1 lists the KST-2000A/B faults and their indication in the LEDs and relays. In some cases, items listed in Table 4-1 give no LED or relay indication when they occur because they are not equipment faults but are useful for troubleshooting problems.

4.3 Stored Faults

Each of the major modules within the KST-2000A/B (Upconverter, Downconverter, HPA, LNA/LNB, and Reference), together with the AGC function and the Common Equipment, report their individual fault status to the main M&C. Each time there is a change in the fault status, that status is stored in a non-volatile memory on the main M&C. Note that each event corresponds to a change in status. Therefore, when a fault occurs, that constitutes one status change, and when that fault clears, another event occurs. The M&C can store up to 10 fault status conditions.

After 10 fault status changes are logged, no further logging can take place until the Clear Stored Faults (<add/CLSF) command is issued. Refer to Appendix B, Table B-7 for the fault commands to access the fault status of each function. When the fault status is queried, such as <add/HS-, the response returned will indicate how many stored faults are actually stored. To retrieve the individual fault status, issue the appropriate stored fault command with the corresponding stored fault number, such as <add/HSF_2. That particular fault condition will be returned. Note that the stored fault numbers (locations) are 0 through 9 inclusive.

It is good maintenance practice to query the stored faults and record them in a logbook or other permanent record and then issue the clear stored fault command, <add/CLSF_. There is no time stamp associated with these stored faults. Noting them in a logbook is the only way to establish an approximate time reference.

Table 4-1. KST-2000A/B Fault Tree

| | R F O U T P U T O F F | T X R F L E D O F F | T X R F L E D S O L I D | T X R F L E D F L A S H I N G | S U M M A R Y F A U L T L E D | S U M M A R Y F A U L T R E L A Y (1) | U L F A U L T R E L A Y (2) | D L F A U L T R E L A Y (3) |
|------------------------------------|---|--|--|---|---|--|---|---|
| COMMON EQUIPMENT FAULTS | | | | | | | | |
| M&C MODULE | | | | | X | X | | |
| -7 VOLT POWER SUPPLY | | | | | X | X | | |
| +7 VOLT POWER SUPPLY | | | | | X | X | | |
| +12 VOLT POWER SUPPLY | | | | | X | X | | |
| +17 VOLT POWER SUPPLY | | | | | X | X | | |
| TX REDUNDANCY SWITCH | | | | | X2 | X2 | | |
| RX REDUNDANCY SWITCH | | | | | X2 | X2 | | |
| IF REDUNDANCY SWITCH | | | | | X2 | X2 | | |
| REDUNDANCY FAULT LINE CABLE | | | | | X2 | X2 | | |
| AGC FAULTS | | | | | | | | |
| EXCESSIVE INPUT POWER | | | | | | | | |
| INSUFFICIENT INPUT POWER | | | | | | | | |
| AGC LOOP CONVERGE | | | | | | | | |
| LNA FAULTS | | | | | | | | |
| LNA MODULE FAULT | | | | | X1 | X1 | | X1 |
| REFERENCE FAULTS | | | | | | | | |
| EXTERNAL 10MHz LOCK DETECT | | | | | X | X | | |
| EXTERNAL PHASE NOISE | | | | | X | X | | |
| EXTERNAL RANGE | | | | | X | X | | |
| 72MHz LOCK DETECT | | | | | X | X | | |
| OSCILLATOR WARM/COLD | | | | X | | | | |
| UC FAULTS | | | | | | | | |
| UC MODULE | X | X | | | X | X | X | |
| S-BAND SYNTHESIZER LOCK DETECT | X | X | | | X | X | X | |
| KU BAND SYNTHESIZER LOCK DETECT | X | X | | | X | X | X | |
| LATCHED S BAND SYNTH. LOCK DETECT | | | | | | | | |
| LATCHED KU BAND SYNTH. LOCK DETECT | | | | | | | | |
| INTER-PROCESSOR COMMUNICATIONS | X | X | | | X | X | X | |
| DC FAULTS | | | | | | | | |
| DC MODULE | | | | | X | X | | X |
| L-BAND SYNTHESIZER LOCK DETECT | | | | | X | X | | X |
| KU BAND SYNTHESIZER LOCK DETECT | | | | | X | X | | X |
| LATCHED L BAND SYNTH. LOCK DETECT | | | | | | | | |
| LATCHED KU BAND SYNTH. LOCK DETECT | | | | | | | | |
| INTER-PROCESSOR COMMUNICATIONS | | | | | X | X | | X |

| | R F O U T P U T O F F | T X R F L E D O F F | T X R F L E D S O L I D | T X R F L E D F L A S H I N G | S U M M A R Y F A U L T L E D | S U M M A R Y F A U L T R E L A Y | U L F A U L T R E L A Y | D L F A U L T R E L A Y |
|--------------------------------------|---|--|--|---|---|---|--|--|
| HPA FAULTS (Comtech EFDData) | | | | | | | | |
| HPA MODULE | X1 | X1 | | | X1 | X1 | X1 | |
| BIAS VOLTAGE #1 - #9 | X1 | X1 | | | X1 | X1 | X1 | |
| -5 VOLT POWER SUPPLY | X1 | X1 | | | X1 | X1 | X1 | |
| +9.75 VOLT POWER SUPPLY | X1 | X1 | | | X1 | X1 | X1 | |
| INTER-PROCESSOR COMMUNICATIONS | X1 | X1 | | | X1 | X1 | X1 | |
| HPA FAULTS (OEM SSPA) | | | | | | | | |
| HPA MODULE | X1 | X1 | | | X1 | X1 | X1 | |
| HPA FAULTS (TWTA) | | | | | | | | |
| HPA MODULE | X1 | X1 | | | X1 | X1 | X1 | |
| HIGH VOLTAGE | X1 | X1 | | | X1 | X1 | X1 | |
| TEMPERATURE | X1 | X1 | | | X1 | X1 | X1 | |

| Legend | | |
|--------|-------------------------------------|-----------------------------|
| Note | Fault/Alarm Relay | Test Points Connector/Pins |
| 1 | SUMMARY FAULT | J2: a (NO), c (COM), b(NC) |
| 2 | UL FAULT | J2: W (NO), V (COM), U (NC) |
| 3 | DL FAULT | J2: Z (NO), Y (COM), X (NC) |
| X1 | FAULTS IF NOT MASKED OFF | N/A |
| X2 | ONLY ACTIVE WHEN REDUNDANCY ENABLED | N/A |

Chapter 5. KEYPAD / DISPLAY

A display overview includes, the menu tree, the organization, the navigating of menu selections, the parameters (ranges) of the programmable values, and finally, the interaction of the keypad/display, remote control (EIA-232, EIA-422, EIA-485) and FSK is explained.

5.1 Keypad/Display Overview

The KST-2000A/B equipped with an optional keypad/display provides the user with a simple method of controlling or monitoring the KST2000 transceiver.

The keypad/display unit is a weatherproof 16 character LED display with 6 keys to provide data entry to the KST-2000A/B. The display characters can easily be seen in bright sunlight as well as dark environments. While the keypad/display is a weatherproof device, a case mounted swing away cover elements adds a second layer of protective isolation. This second cover will ensure the keypad/display is protected from the natural elements such as the sun, rain, and snow and can also protect the display during a system installation or transportation.

5.2 Front Panel Keypad/Display

The front panel (Figure 5-1) provides the local user interface, which can be used to configure and monitor the status of the terminal.

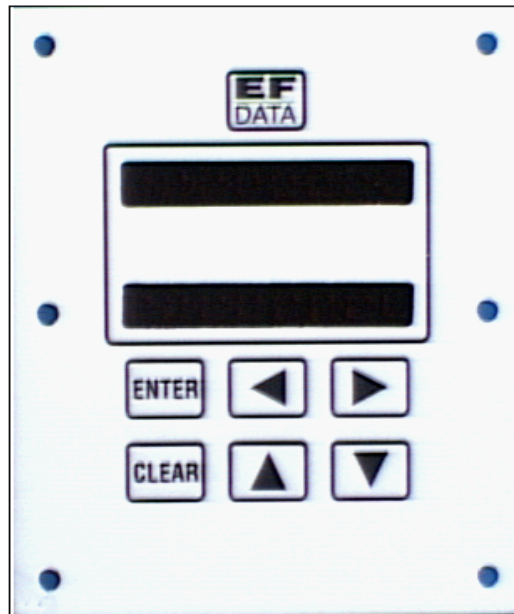

Figure 5-1. KST-2000A/B Terminal Keypad

The front panel features a 16-character, 2-line LED display, and a 6-button keypad which provides for sophisticated functions, yet is easy to use. All functions are accessible at the front panel by entering one of six main categories of “SELECT” menus:

- Configuration (CONFIG)
- Monitor
- Faults
- Utility
- System
- Redundancy (REDUNDCY)

5.2.1 Front Panel Controls

The terminal is locally operated by using the front panel keypad. The keypad consists of six keys. Each key has its own logical function or functions.

| Key | Description |
|-------------|---|
| [ENTER] | This key is used to select a displayed function or to execute a change to the terminal's configuration. |
| [CLEAR] | This key is used for backing out of a selection or to cancel a configuration change, which has not been executed using [ENTER]. Pressing [CLEAR] generally returns the display to the previous selection. |
| [◀] and [▶] | These keys are used to move to the next selection, or to move the cursor for certain functions. |
| [▲] and [▼] | These keys are used primarily to change configuration data (numbers), but are also used at times to move from one section to another. |

The terminal front panel control uses a tree-structured menu system (Figure 5-3) to access and execute all functions. The base level of this structure is the sign-on message, which is displayed at the front panel upon terminal power-up (Figure 5-2).

- Line 1 of the sign-on message displays the terminal model number.
- Line 2 displays the version number of the firmware implemented in the terminal.

Note: The firmware/software referenced in this manual may be an earlier version of the actual firmware/software supplied with the unit.



Figure 5-2. KST-2000A/B Sign On Message

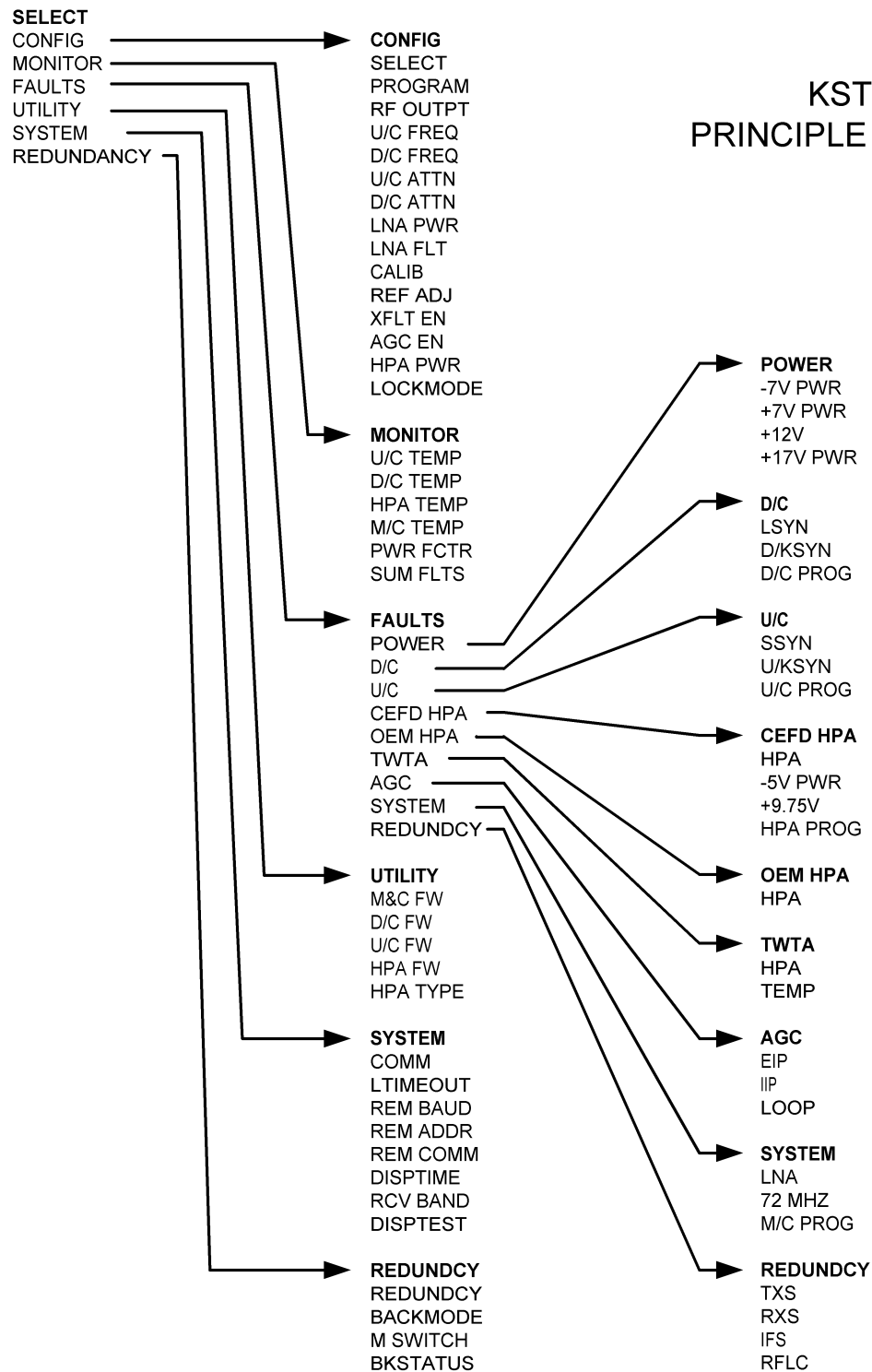

Figure 5-3. Principle Menu Trees

5.3 The Menu Structure

The main level of the menu system is the SELECT: CONFIG menu (Figure 5-4), which may be accessed from the base level by pressing any of the arrow keys. From the SELECT menu, any one of six functional categories may be selected:

- Configuration functions (CONFIG)
- Monitor functions
- Fault functions
- Utility functions
- System functions
- Redundancy functions

Press [◀] or [▶] to move from one selection to another.



Figure 5-4. Select Menu

When the desired category is displayed on line 2, press [ENTER]. Once the category has been entered, move to the desired function by pressing [◀] or [▶].

5.3.1 Configuration

Terminal configuration may be viewed or changed by entering the CONFIG menu (below) from the SELECT menu on the front panel.

Enter the selected configuration menu by pressing [ENTER]. Press [◀] or [▶] to view the selected configuration parameters. To change a configuration parameter, press [ENTER] to begin the change process, at which point the arrow keys can be used to make the changes.

After the changes are made and the display represents the correct parameters, execute the change by pressing [ENTER]. When [ENTER] is pressed, the necessary programming is initiated by the KST-2000A/B.

To undo a parameter change prior to executing it, simply press [CLEAR].



Figure 5- 5. Configuration Menu

The following listing describes each Configuration function in detail.

| Function | Description |
|-----------|--|
| SELECT | <p>Selects any one of the three "preset" configurations.</p> <p>The user must first program (store) the configuration parameters in the PROGRAM menu. This "select" function is similar to the "recall" portion of a "save/recall" parameter feature. Note: This function will recall and program the up and down converter frequencies and attenuation values that were stored in program locations 1, 2, or 3.</p> <p>On entry, the current Select parameter will appear in the menu. Press [▲] or [▼] to select 1, 2, 3, or None. Press [ENTER] to execute the change. If the user has not previously programmed any settings using the PROGRAM menu, the Select menu option will be "None" and it will not be possible to load any user selectable parameters.</p> |
| PROGRAM | <p>Programs or clears the current frequency and attenuator settings as one of the three "preset" selections.</p> <p>On entry, 1*, 2*, or 3* will appear in the window. Note: 1, 2, 3, or any combination of the "*" or " " indicators can also appear depending on which user program locations are currently used. Press [◀] or [▶] to move the cursor from left to right. When the flashing cursor is on any of the "*"s, press [▲] or [▼] to turn the "*" ON or OFF. When the "*" is ON, press [ENTER] to store the current frequency and attenuation parameters in the preset location at the cursor. When the "*" is OFF, press [ENTER] to clear stored parameters in the preset location to the left of the "*". To recall any of the present selections, use the SELECT menu, and select 1, 2, or 3. Press [ENTER].</p> |
| RF OUTPUT | <p>Programs the RF output to ON, WRM, or OFF.</p> <p>The OFF command will keep the RF output turned off under all conditions. The WRM command is a conditional ON command telling the RF output to come on after the unit is warmed up and meets the stability requirements. The ON command is an override instructing the output to be on and ignores the warm start.</p> <p>On entry, the current status of the output is displayed. Press an Arrow key to select ON, WRM, or OFF. Press [ENTER] to execute the change.</p> |
| U/C FREQ | <p>Programs the up converter frequency between 13.75 and 14.50 MHz, in 1.0 MHz steps.</p> <p>On entry, the current up converter frequency is displayed with the flashing cursor on the first programmable character. Press [◀] or [▶] to move the flashing cursor. Press [▲] or [▼] to increment or decrement the digit at the flashing cursor. Press [ENTER] to execute the change.</p> <p>Note: The frequency is programmable within the specified range in 1.0 MHz steps. When the transmitter frequency is changed, the transmitter is automatically turned OFF to prevent the possible swamping of other channels. To turn the transmitter ON, use the RF OUTPT (RF output) menu.</p> |
| D/C FREQ | <p>Programs the down converter frequency between 10.95 and 12.75 MHz, in 1.0 MHz steps.</p> <p>On entry, the current down converter frequency is displayed with the flashing cursor on the first programmable character. Press [◀] or [▶] to move the flashing cursor. Press [▲] or [▼] to increment or decrement the digit at the flashing cursor. Press [ENTER] to execute the change.</p> |

| | |
|----------|--|
| U/C ATTN | <p>Programs the up converter output power attenuation from 0 to 25 dB, in 1.0 dB steps.</p> <p>On entry, the current up converter attenuation is displayed with a flashing cursor. Press [▲] or [▼] to increase or decrease the output power attenuation in 1.0 dB steps. Press [ENTER] to execute the change.</p> |
| D/C ATTN | <p>Programs the down converter input power attenuation from 0 to 20 dB, in 1.0 dB steps.</p> <p>On entry, the current down converter attenuation is displayed with a flashing cursor. Press [▲] or [▼] to increase or decrease the input power attenuation in 1.0 dB steps. Press [ENTER] to execute the change.</p> |
| LNA PWR | <p>Programs the setting that provides power to the LNA or LNB.</p> <p>Options are "OFF" or "ON". "ON" means LNA power will be available on the center conductor of the coax cable (J4). "OFF" means DC power will be removed from the coax cable. LNA voltage typical: 15 VDC, 20% tolerance.</p> |
| LNA FLT | <p>Programs the LNA fault enable parameter.</p> <p>"ON" means the system will declare an LNA fault when applicable. "OFF" means all LNA faults will be ignored by the system.</p> |
| CALIB. | <p>Calibrates the LNA power consumption.</p> <p>Enables the user to calibrate the unit to determine the normal LNA or LNB power consumption. This only needs to be performed once during the initial installation. If [ENTER] is pressed, the M&C will perform an analog-to-digital conversion of the LNA current, and store the value in the Electrically-Erasable Programmable Read-Only Memory (EEPROM). During the normal operation, the M&C will monitor the LNA current, and compare it to the stored value. If the LNA deviates by $\pm 30\%$, a fault will be declared.</p> |
| REF ADJ | <p>Allows adjustment of the 10.000 MHz reference frequency to compensate for long-term drift. The setting varies from 1 to 255.</p> |
| XFLT EN | <p>Enables or disables the external fault input.</p> <p>When ON is selected, all of the HPA, SSPA, and TWTA faults work normally. When OFF is selected, the HPA, SSPA, and TWTA faults will be masked and not reported via the display or remote control.</p> |
| AGC EN | <p>Automatic Gain Control enable or disable.</p> <p>When ON is selected, the AGC function maintains the system gain, as measured from the TX IF input to the Ku-Band output of the Comtech supplied SSPA, at the user's preset value despite the effects of aging, operating temperature, or cabling loss. If "OFF" is selected, system gain will not be monitored or controlled. Note: also when AGC is programmed to the "OFF" mode, the up converter attenuation will not display a decimal point as a courtesy indication that the AGC function is off.</p> |
| HPA PWR | <p>HPA power enable or disable.</p> <p>On entry, the currently selected parameter will appear. Press an Arrow key to select ON or OFF. Press [ENTER] to execute the change. When ON is selected, the DC voltage is supplied to the HPA. Note: This command is for Comtech EF Data SSPAs only. Selecting "OFF" removes power from the SSPA.</p> |
| LOCKMODE | <p>Locks the keypad/display to prevent the changing of data.</p> <p>Options are LOCKED and DISABLED. When "DISABLED" is selected, the keypad/display will operate normally. If "LOCKED" is selected, the [Enter] key is disabled a brief message is displayed indicating the keypad is in lock mode. Selecting LOCKMODE "DISABLED" will restore the keypad/display to its normal operating mode.</p> |

5.3.2 Monitor

The SELECT: MONITOR (Figure 5-6) menu is accessible from the SELECT menu. When the MONITOR menu is entered, press [◀] or [▶] to select the desired function.

Each monitor function is displayed in real time for as long as it is selected.



Figure 5-6. Monitor Menu

The following listing describes each monitor function in detail.

| Function | Description |
|----------|---|
| U/C TEMP | Up converter temperature monitor. Range: -40 to +90° C (-40 to 194° F) |
| D/C TEMP | Down converter temperature monitor. Range: -40 to +90° C (-40 to 194° F) |
| HPA TEMP | HPA temperature monitor. Range: -40 to +90° C (-40 to 194° F) |
| M&C TEMP | M&C temperature monitor. Range: -40 to +90° C (-40 to 194° F) |
| PWR FCTR | The PWR FCTR is a power factor of the output power of the CEFD HPA. In actuality, power factor is a very close indication of the output power. This function is only available with Comtech supplied SSPAs. |
| SUM FLTS | SUM FLTS are the summary faults of the complete KST-2000A/B system. If there are any faults present, they can be seen via a FLT indication in this menu. |

5.3.3 Faults

The SELECT: FAULTS menu is accessible from the SELECT menu (Figure 5-7). Upon entry, from the Select Menu, a Select Sub-level menu is displayed (Figure 5-8) allowing access to several categories of faults.

The "*" indicator surrounding the *SELECT* display indicates the user is in the FAULTS sub menu.

Press the [◀] or [▶] keys to select the desired fault category. Pressing [Enter] will enter the indicated faults category and display the current status "OK" or "FLT" for the displayed KST-2000A/B system. Pressing any arrow key will display the next monitored system. Pressing the [Clear] key once will return the user to the faults menu, while pressing the [Clear] key twice will return the user to the main SELECT menu.

Note: The upper level SELECT menu indicates "-SELECT-" while the faults menu indicates "*SELECT*". This is done to distinguish the upper level select from the faults level select menus.



Figure 5-7. Faults Menu



Figure 5-8. Faults Sub-Level

The following listing describes each fault function in detail.

| Function | Description |
|-----------------|--|
| POWER | Monitors the specific voltages as indicated below |
| -7V PWR | -7 VDC "FLT" indicates the -7 VDC is out of the allowable range. |
| +7V PWR | +7 VDC "FLT" indicates the +7 VDC is out of the allowable range. |
| +12V | +12 VDC "FLT" indicates the +12 VDC is out of the allowable range. |
| +17V PWR | +17 VDC "FLT" indicates the +17 VDC is out of the allowable range. |
| D/C | Down Converter |
| D/C | "FLT" indicates a down converter module fault. |
| LSYN | L-Band synthesizer lock fault |
| D/KSYN | K-Band synthesizer lock fault |
| D/C PROG | D/C programming Fault "FLT" Indicates the main M&C has lost communication with the micro-controller on the down converter assembly. |
| U/C | Up Converter |
| U/C | "FLT" indicates an up converter module fault |
| SSYN | S-Band synthesizer lock fault |
| U/KSYN | Ku-Band synthesizer lock fault |
| U/C PROG | U/C programming fault "FLT" Indicates the main M&C has lost communication with the micro-controller on the up converter assembly. |
| CEFD HPA | Comtech EF Data High Powered Amplifier |
| HPA | HPA fault "FLT" indicates the HPA module micro-controller has reset. |
| -5V PWR | -5 VDC "FLT" indicates the HPA -5VDC is out of the allowable range. |
| +9.75V | +9.75 VDC "FLT" indicates the HPA +9.75 VDC is out of the allowable range. |
| HPA PROG | HPA programming fault "FLT" Indicates the main M&C has lost communication with the micro-controller on the CEFD SSPA. |
| OEM HPA | |
| HPA | HPA fault "FLT" is a summary fault for one of the internal fault monitoring systems within the OEM HPA. |
| TWTA | Traveling wave tube amplifier |
| HPA | HPA fault "FLT" is a summary fault for one of the internal fault monitoring systems within the TWTA. |
| TEMP | Temperature fault "FLT" Indicates excessive temperature within the TWTA. |
| AGC | Automatic Gain Control |
| EIP | Excessive Input Power "FLT" indicates input power is too high and may need to be attenuated. |
| IIP | Insufficient Input Power "FLT" indicates low power input or no input at all. |

| | |
|-----------------|--|
| LOOP | AGC loop fault "FLT" usually with EIP or IIP "FLT" above. "FLT" indicates the AGC loop circuit not tracking the input or output properly. |
| SYSTEM | |
| LNA | LNA fault "FLT" indicates the current monitor has detected an out of range current value. |
| 72 MHZ | 72 MHz oscillator fault |
| M/C PROG | M&C programming fault "FLT" indicates the M&C cannot communicate to one or more devices on the M&C assembly. |
| REDUNDCY | |
| TXS | Transmit switch "FLT" indicates the WG switch transmit side not operating or not indicating position properly. |
| RXS | Receive switch "FLT" indicates the WG switch receive side not operating or not indicating position properly. |
| IFS | IF switch Located in the RJU-503. "FLT" indicates the IF switch not operating or not indicating position properly. |
| RFLC | Redundancy cable "FLT" indicates backup operation is selected and the KST-2000A/B detects a discontinuity in the redundancy cable. |

5.3.4 Utility

The SELECT: UTILITY (Figure 5-9) menu is accessible from the SELECT menu. When the UTILITY menu is entered, press [◀] or [▶] to select the desired function.

The utility menu is where the system firmware information can be found along with the type of HPA used with the system. In this utility menu, the down arrow key [▼] acts as a second function key that will display additional information about the currently displayed item.



Figure 5-9. Utility Menu

| Function | Description |
|--------------|---|
| M&C Firmware | Displays the M&C firmware number and revision. The release date can be displayed by pressing the down arrow key [▼]. |
| D/C Firmware | Displays the down converter firmware number and revision. The release date can be displayed by pressing the down arrow key [▼]. |
| U/C Firmware | Displays the up converter firmware number and revision. The release date can be displayed by pressing the down arrow key [▼]. |
| HPA Firmware | Displays the HPA firmware number and revision. The release date can be displayed by pressing the down arrow key [▼]. |
| HPA Type | Displays the HPA type: CEFD, OEM, or TWTA For CEFD HPAs, the specified wattage of the HPA can be displayed by pressing the down arrow key [▼]. |

5.3.5 System

The SELECT: SYSTEM (Figure 5-10) menu is accessible from the SELECT menu. When the SYSTEM menu is entered, press [◀] or [▶] to select the desired function.



Figure 5-10. System Menu

The system menu is where the operating parameters of the KST-2000A/B can be configured. The remote communications parameters can be set (address, baud rate, parity) as well as the setting for local (keypad) or remote mode of operation. Settings that affect the display can be configured in this menu. The selection of one of three receive bands can be set (KST-2000B only).

| Function | Description |
|----------|---|
| COMM | <p>Selects between Remote and Local operation.</p> <p>Remote mode is the default mode of communication. The communications priority is defined as: 1. Remote control, 2. FSK. With REMOTE is selected; the EIA-232, EIA-422, and EIA-485 communication is active. FSK will be enabled approximately 10 seconds after the last EIA-232, EIA-422, or EIA-485 message has been completed.</p> <p>If the user is using the keypad/display, LOCAL would be selected. In local mode, all remote communications are disabled (including FSK). This prevents more than one user from having control of the KST-2000A/B at the same time. Remote communications can be re-enabled at any time simply by selecting "REMOTE" in the SYSTEM>COMM menu.</p> |

| | |
|----------|--|
| LTIMEOUT | <p>Sets the Local mode timeout.</p> <p>As stated above, remote mode is the default mode of operation. The KST-2000A/B will automatically switch from LOCAL mode to REMOTE mode after the last key press has occurred <i>and</i> the time period set in the LTIMEOUT menu has expired. The time is configurable from 1-9 hours (default = 4 hrs) and starts counting after the last key press has occurred.</p> <p>Note: If the system has returned to remote mode, local communications can be re-enabled at any time by selecting "LOCAL" in the SYSTEM>COMM menu.</p> |
| REM BAUD | <p>Programs the baud rate of the terminal.</p> <p>On entry, the currently selected baud rate of the terminal will be displayed. To change the baud rate, press [▲] or [▼] to select a baud rate from 300 to 19200 baud. Press [ENTER] to execute the changes. Available baud rates are 300, 600, 1200, 2400, 4800, 9600 and 19200.</p> |
| REM ADDR | <p>Programs the terminal remote address.</p> <p>On entry, the currently selected address of the terminal is displayed with the flashing cursor on the "ones" character. Press [▲] or [▼] to change the desired address of the terminal from 1 to 255. The [◀] or [▶] arrow buttons allow skipping to the "tens" or "hundreds" columns. Press [ENTER] to execute the change.</p> |
| REM COMM | <p>Programs the parity bit to EVEN, ODD or NONE.</p> <p>On entry, the currently selected parity is displayed. Changing parity can also affect the number of data bits and stop bits. Press an Arrow key to select one of the valid options: 7,E,2 (default), 7,O,2, or 8,N,1. Press [ENTER] to execute the change.</p> |
| DISPTIME | <p>Programs the amount of time the display will stay illuminated. After the time expires, the display will go dark until any key is pressed. Display time range is 10-999 seconds. Default 300 seconds (5 minutes).</p> |
| RCV BAND | <p>KST-2000B only. Sets the receive band to one of three bands: Band A: 10.950 - 11.700 GHz Band B: 11.700 - 12.200 GHz Band C: 12.250 - 12.750 GHz</p> |
| DISPTEST | <p>Tests the display characters by rotating through the alphanumeric character set.</p> |

5.3.6 Redundancy

The SELECT: REDUNDANCY (Figure 5-11) menu is accessible from the SELECT menu. When the REDUNDANCY menu is entered, press [◀] or [▶] to select the desired function.



Figure 5-11. Redundancy Menu

The redundancy menu category provides all of the necessary controls to configure a redundant KST-2000A/B system. The backup transceiver can be manually switched to be the "online" unit with a few button presses. Auto dependency or independency can switch an up converter, down converter or both if desired and a real time backup status monitor can be observed by selecting the BKSTATUS menu display.

| Function | Description |
|----------|-------------|
|----------|-------------|

| | |
|----------|--|
| REDUNDCY | <p>Redundancy enable.</p> <p>In order to enable a redundant system, the redundancy control must be switched to "YES". "YES" forces the KST to become aware that another KST needs to be considered for backup situations when faults occur.</p> <p>Note: If the redundancy interconnect cable is not connected, a "CABLE NA" message will be displayed. Further redundant configuration is not possible until the cable is connected.</p> |
| BACKMODE | <p>Sets the backup mode</p> <p>Options: MANUAL (default) forces the unit to switch from an OFFLINE mode to an ONLINE mode regardless of what the other is doing.</p> <p>Auto-dependent (AUTO-DEP) forces the unit to automatically switch from an OFFLINE mode to an ONLINE mode depending upon whether or not a fault has occurred in the other unit. It forces the unit to relinquish control of both the UL and DL when a fault occurs on either link. The other unit will pick up control of both the UL and DL when this occurs.</p> <p>Auto-independent (AUTO-IND) forces the unit to automatically switch from an OFFLINE mode to an ONLINE mode depending upon whether or not a fault occurred in the other unit. It forces the unit to independently relinquish control of either the UL or DL when a fault occurs in that specific link. When a fault occurs on a link for one unit the other unit will pick up control of that specific link.</p> |
| M SWITCH | <p>Backup Manual Operation</p> <p>Options: DLUL, DL, UL</p> <p>DLUL: forces the unit to make the DL and UL ONLINE.</p> <p>DL: forces the unit to make the DL ONLINE and UL OFFLINE.</p> <p>UL: forces the unit to make the UL ONLINE and DL OFFLINE.</p> <p>Note: This menu option is only displayed if the BACKMODE (above) menu selection is set to MANUAL.</p> |
| BKSTATUS | <p>Backup Status</p> <p>Real time display of the UL and DL status: ONLINE or OFFLINE where OFFLINE indicates the specific link that is not under the influence of the machine that reported this status.</p> <p>Note: Due to display limits, the UL and DL status will alternate status every second.</p> |

Appendix A. EQUIPMENT OUTLINE DRAWINGS

This section describes the equipment outlines for the following components:

- 2 and 4 Watt SSPA
- 8 Watt SSPA
- 16 Watt SSPA
- 25/32/40 Watt SSPA
- Ku-Band LNA/LNB
- KST-2000A/B Converter

Refer to the applicable section for more detailed information.

A.1 2 and 4 Watt SSPA Equipment Outline

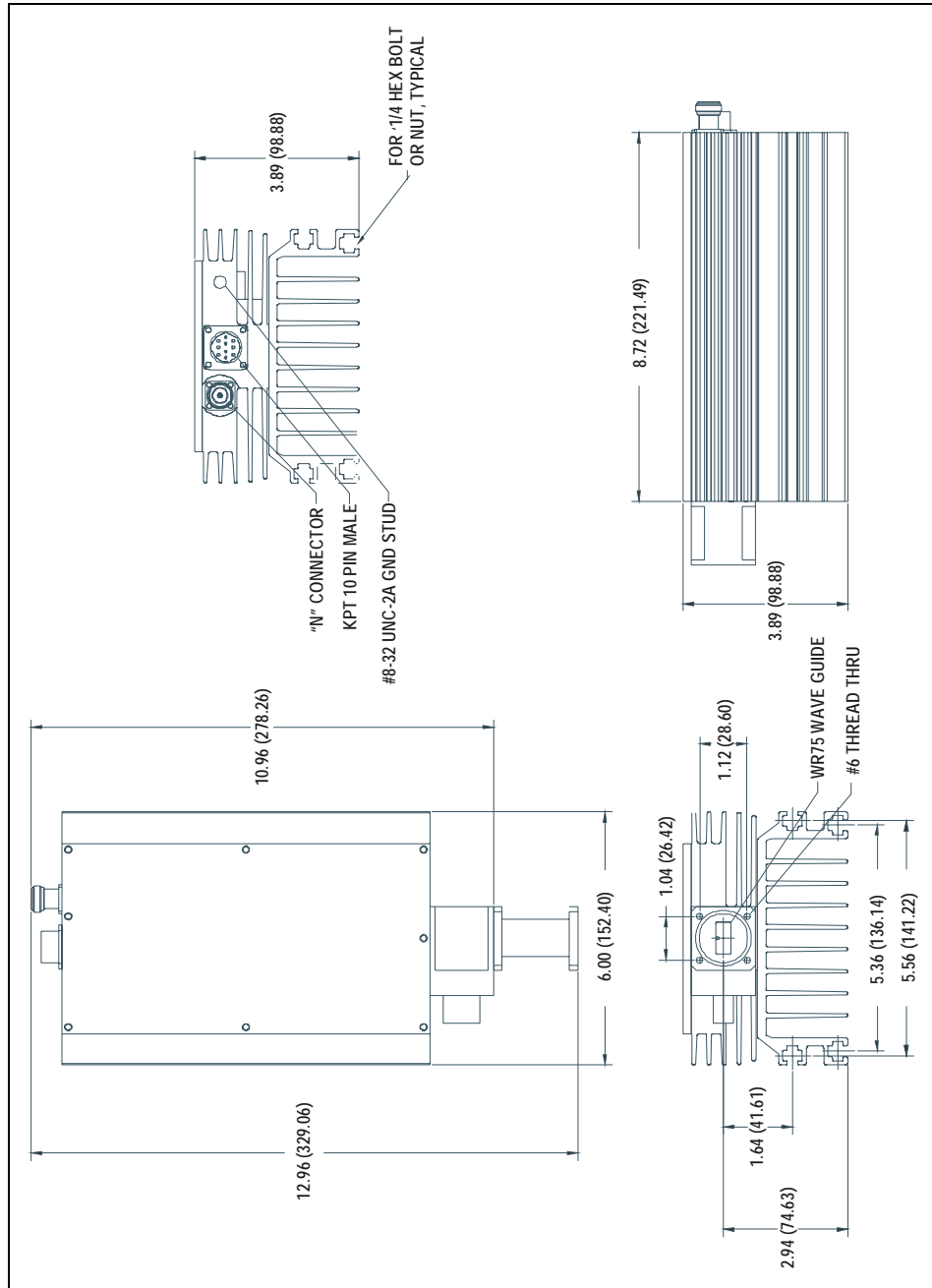

Figure A-1. 2 and 4 Watt SSPA Equipment Outline

A.2 8 Watt SSPA Equipment Outline

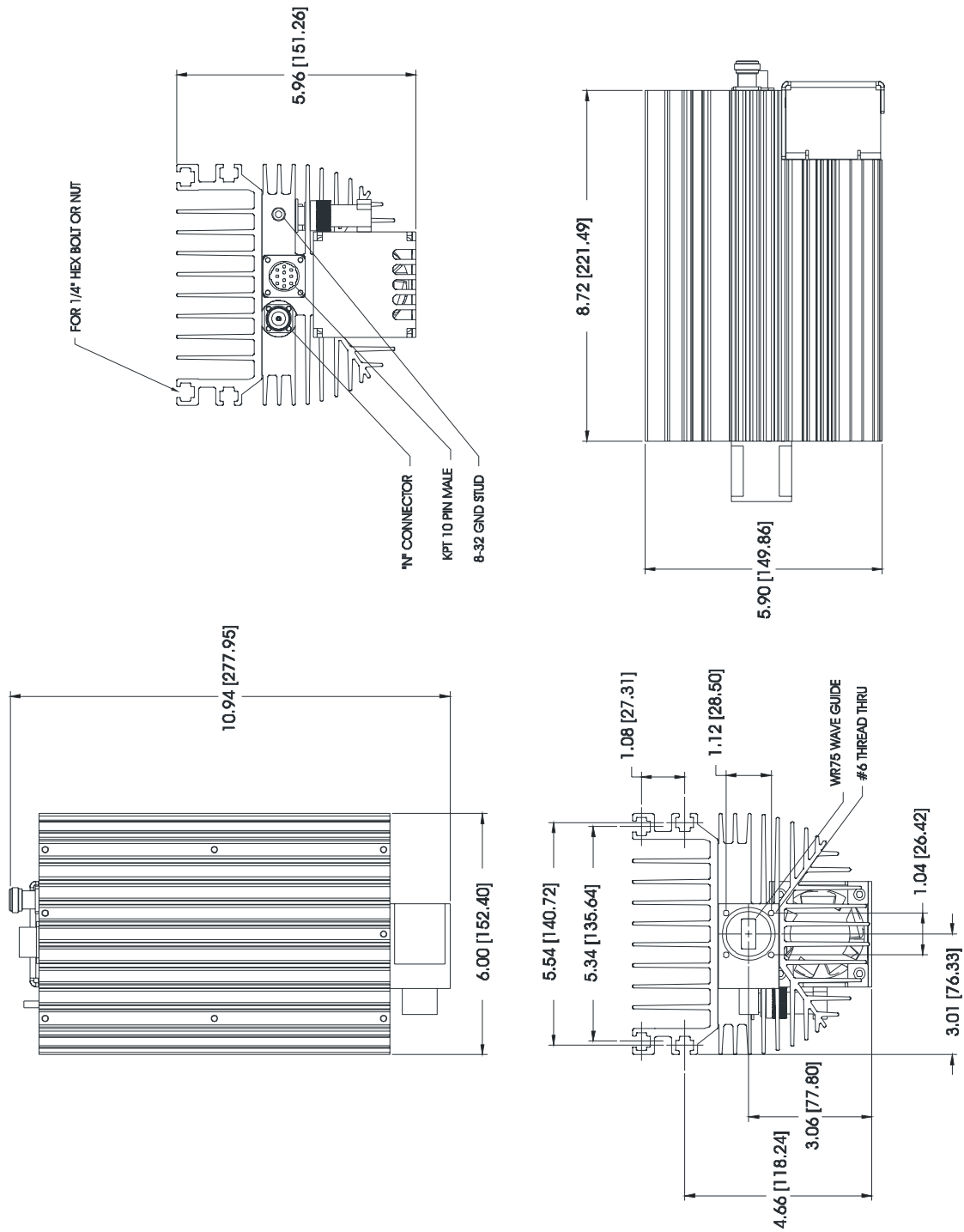

Figure A-2. 8 Watt SSPA Equipment Outline

A.3 16 Watt SSPA Equipment Outline

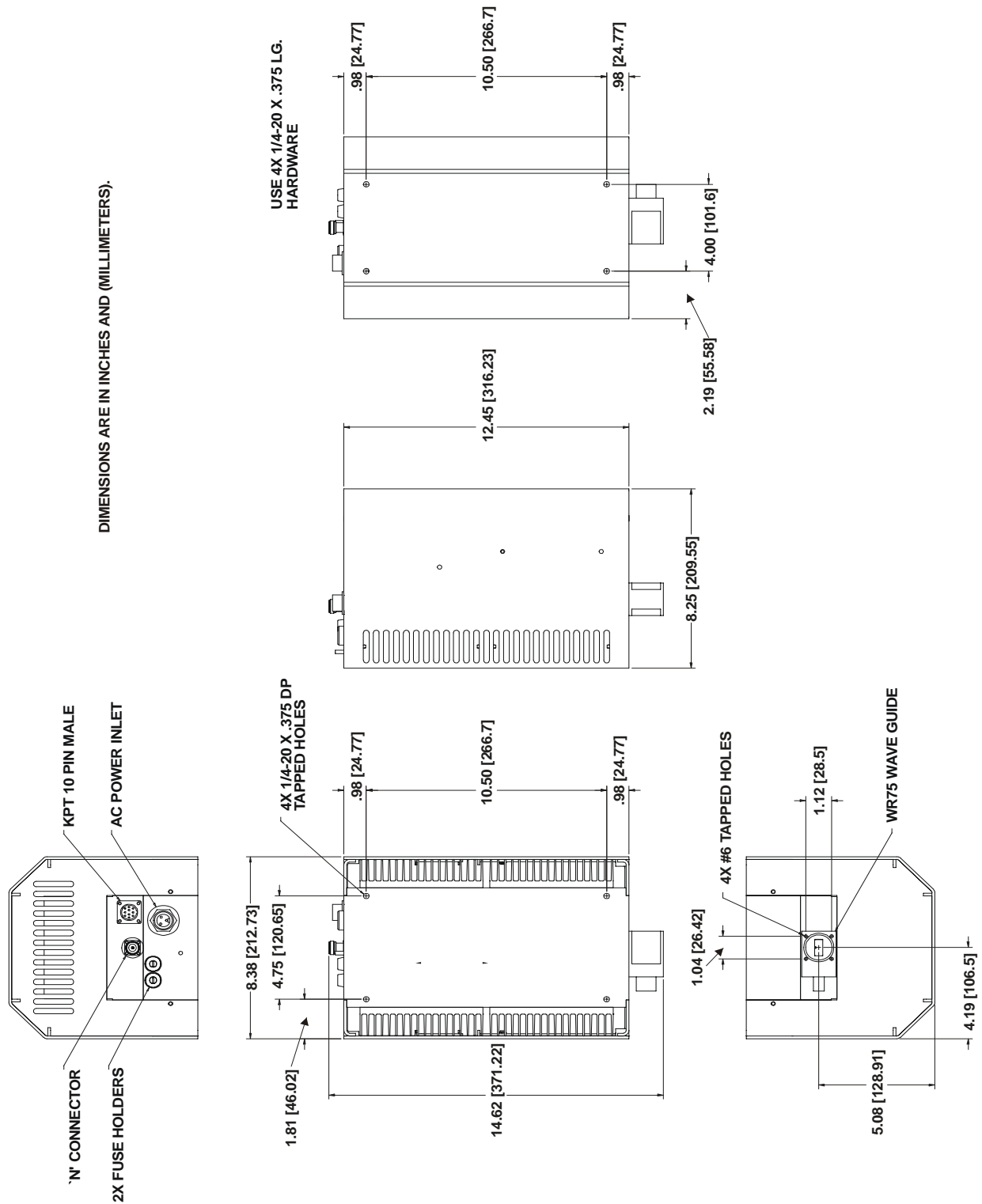

Figure A-3. 16 Watt SSPA Equipment Outline

A.4 25/32/40 Watt SSPA Equipment Outline

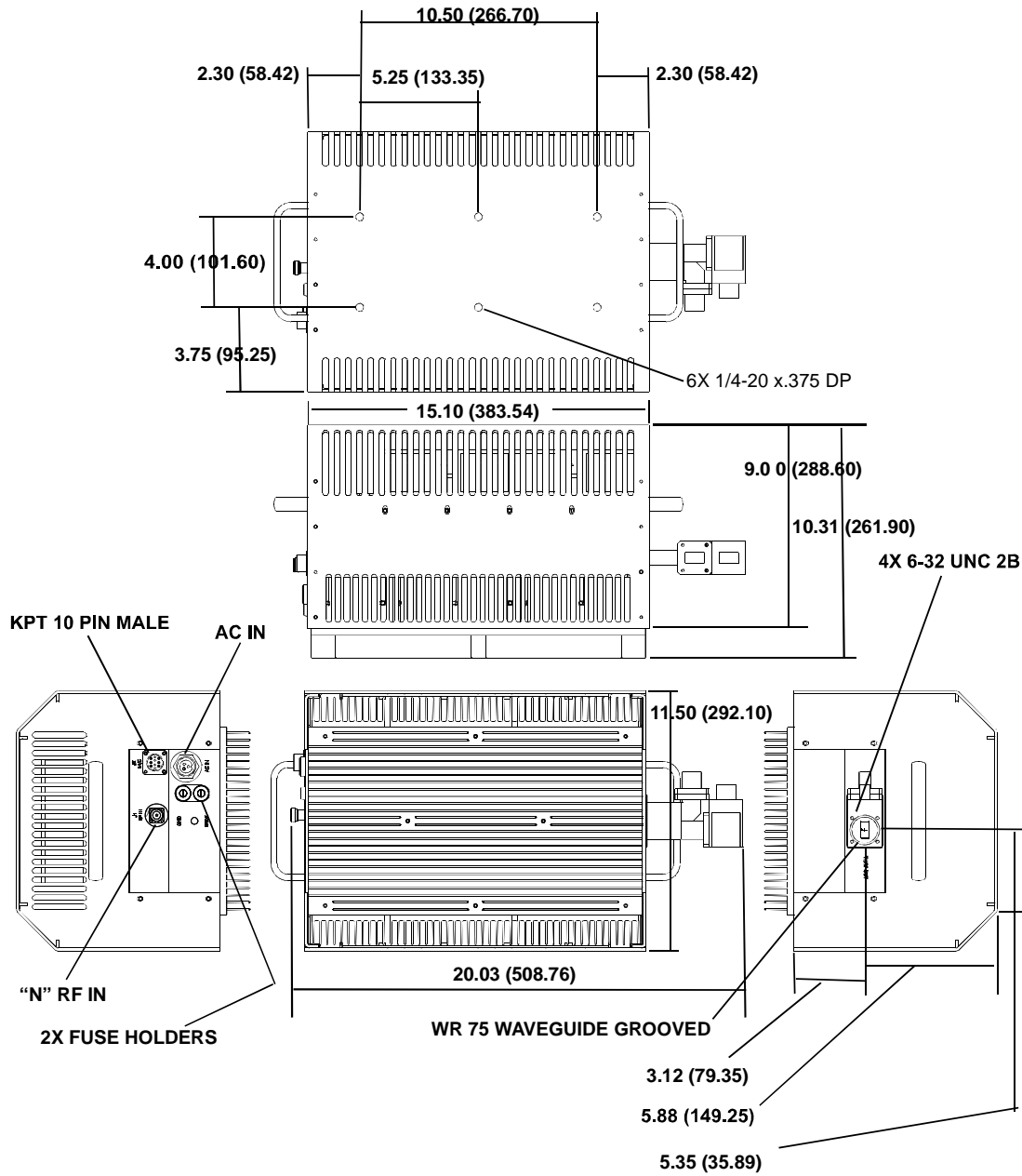

Figure A-4. 25/32/40 Watt SSPA Equipment Outline

A.5 Ku-Band LNA Equipment Outline

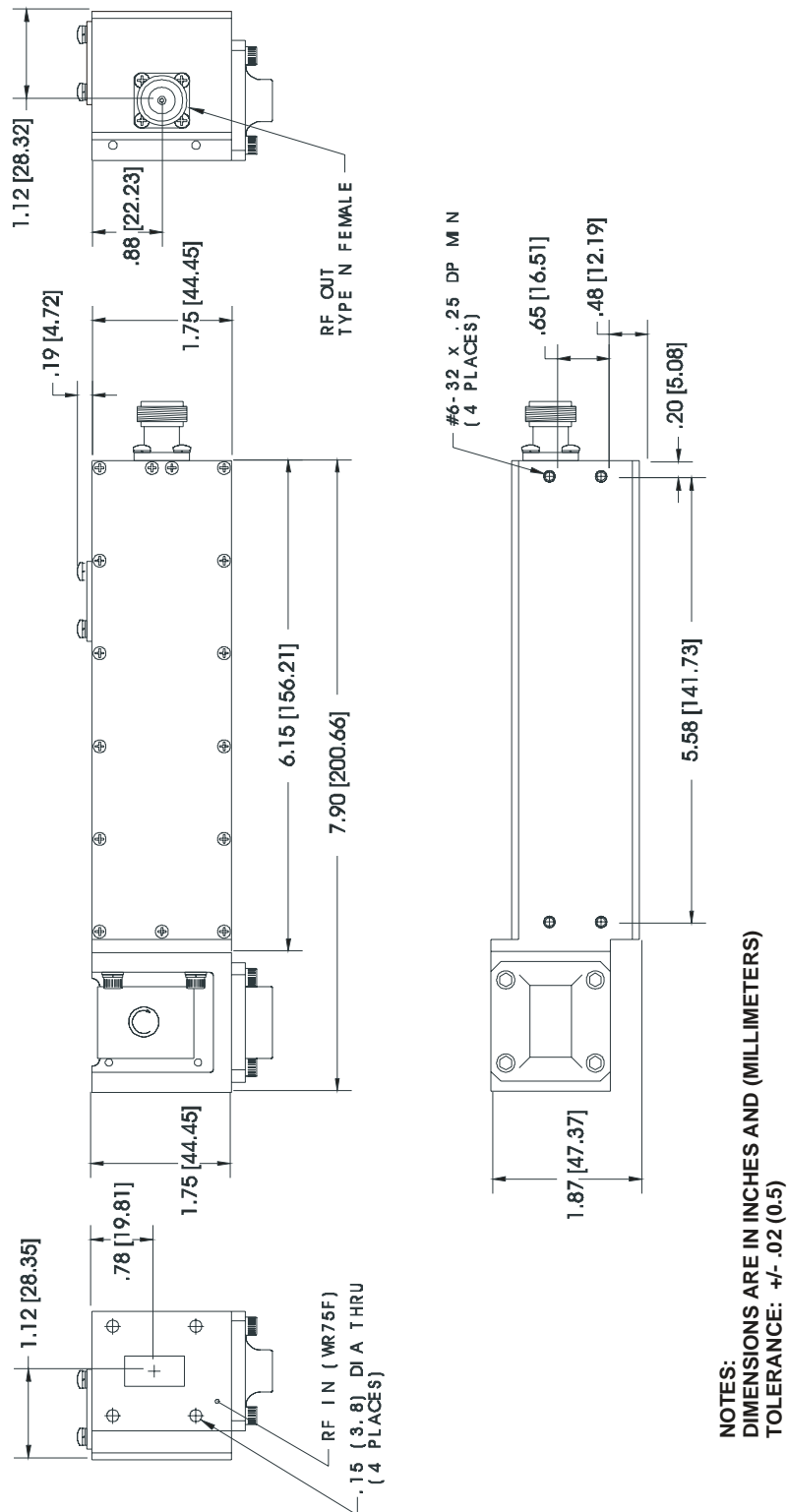

Figure A-5. Ku-Band LNA Equipment Outline

A.6 KST-2000A/B Converter Equipment Outline

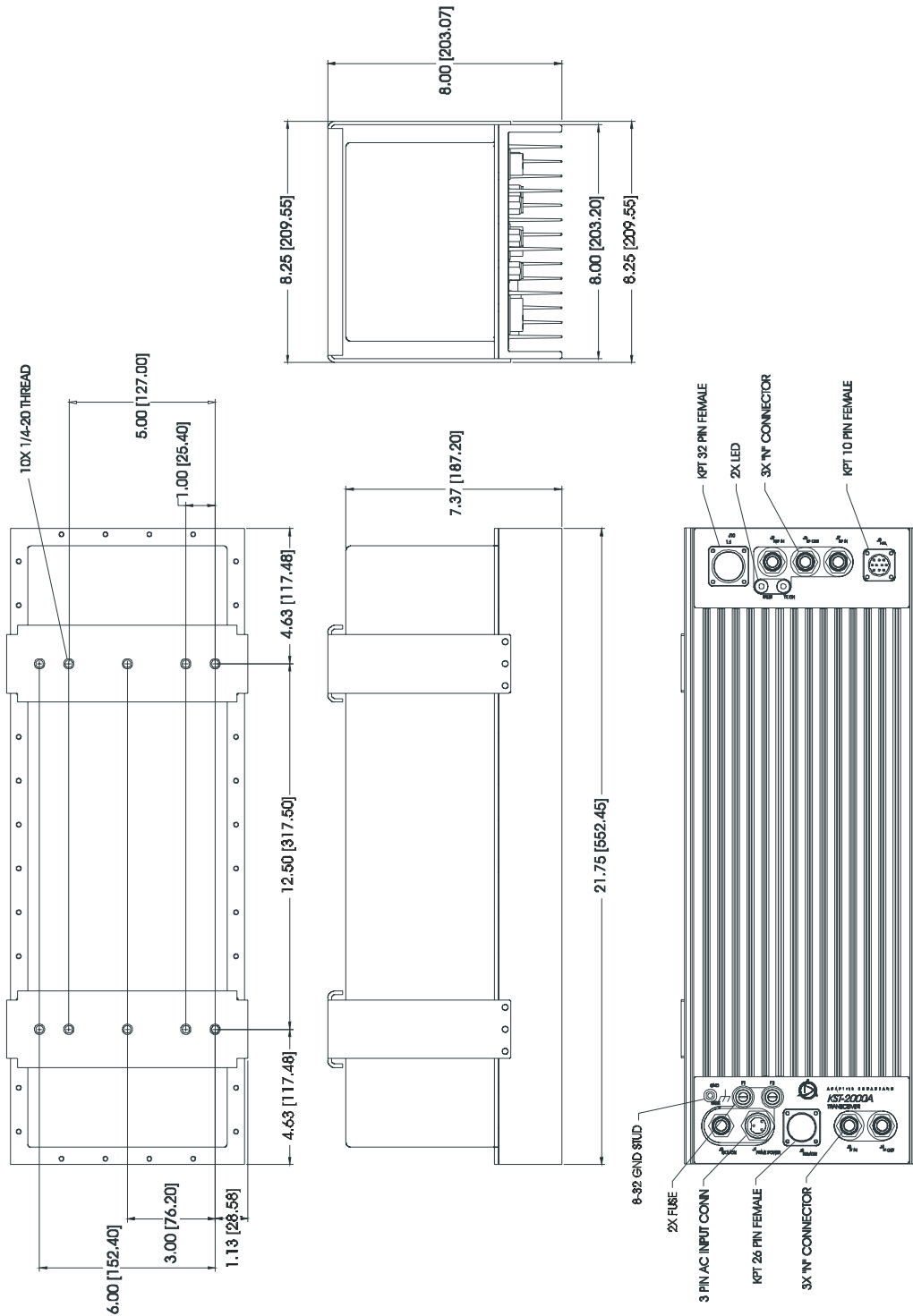

Figure A-6. KST-2000A/B Converter Equipment Outline

A.7 Ku-Band LNB Equipment Outline

Note: All dimensions are in inches, millimeters are in parenthesis.

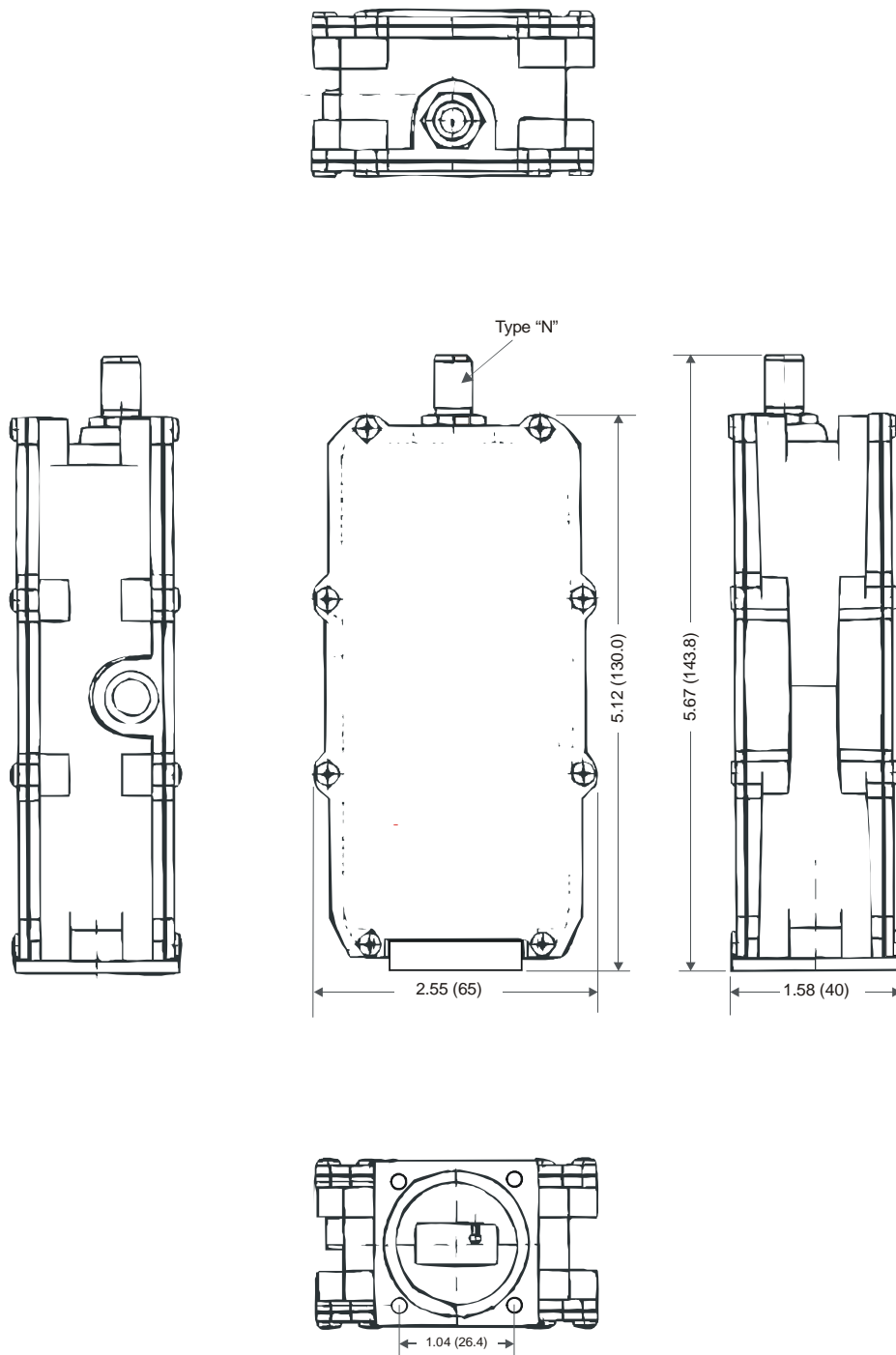

Figure A-7. Ku-Band LNB Equipment Outline

Appendix B. TERMINAL MODE COMMANDS

This appendix defines the protocol and command structure for remote control and status monitoring of the KST-2000A/B in the terminal mode of the Windows™ based M&C remote control software and on the KP-10 keypad.

- Firmware number: FW/10303-1D
- Software version: 1.1.5

B.1 General

The commands for Firmware 10303-1 are listed in this manual. The following table show evolution of the firmware. Contact Comtech EF Data, Customer Support Department, if there is a problem or concern regarding the firmware.

| Firmware | Revision | Version | Remarks |
|----------|----------|---------|-------------------|
| 7084-1 | K | 2.1.1 | No FSK and Keypad |
| 9364-1 | D | 3.1.1 | FSK and No Keypad |
| 10303-1 | D | 1.1.5 | FSK and Keypad |

Remote control and status information are transferred via an EIA-485, EIA-422 or EIA-232 serial communications link. Commands and data are transferred on the remote control communications link as ASCII encoded character strings. The remote communications link is operated in a half duplex mode. Communications on the remote link are initiated by a remote controller or terminal. The KST-2000A/B never transmits data on the link unless it is commanded to do so.

B.2 Message Structure

The ASCII character format used requires 11 bits/character: 1 start bit, 7 information bits, 1 parity bit (odd/even) and 2 stop bits, or 1 start bit, 8 information bits with no parity bit (none) and 2 stop bits. The default format is 7 information bits, even parity, and 2 stop bits (7,E,2). Messages on the remote link fall into the categories of commands and responses. Commands are messages which are transmitted to the KST-2000A/B, while responses are messages returned by the KST-2000A/B in response to a command.

The general message structure is as follows:

- Start Character
- Device Address 'add'
- Command/Response
- End of Message Character 'cr'

B.2.1 Start Character

A single character precedes all messages transmitted on the remote link. This character flags the start of a message. This character is:

- “<” for commands
- “>” for responses

B.2.2 Device Address

The device address is the address of the KST-2000A/B which is designated to receive a transmitted command or which is responding to a command. Valid device addresses are 1 to 3 characters long and in the range of 0 to 255. Address 0 is reserved as a global address, which simultaneously addresses all devices on a given communications link. Devices do not acknowledge global commands.

KST-2000A/Bs which are connected to a common remote communications link must be assigned their own unique address. Addresses are software selectable and must be in the range of 1 to 255.

Notes:

1. 'add' is used to indicate a valid 1 to 3 character device address in the range between 0 and 255.
2. Global address '*' is reserved for EXTERNAL KEYPAD (KP-10) commands.

B.2.3 Command/Response

The command/response portion of the message contains a variable length character sequence, which conveys command and response data. If a KST-2000A/B receives a message addressed to it, which does not match the established protocol or can not be implemented, a negative acknowledgement message is sent in response. This message is:

```
>add/?ER2 INVALID PARAMETER'cr''lf']
```

(error message for a recognized command which cannot be implemented or has parameters which are out of range)

```
>add/?ER3 UNRECOGNIZABLE COMMAND'cr''lf']
```

(error message for unrecognizable command or bad command syntax)

```
>add/?ER4_CONTROLLER IN LOCK MODE'cr''lf']
```

(controller in LOCK mode, DISABLE lock mode before changing any configurable parameters)

```
>add/?ER5_HARD CODED PARAMETER'cr''lf']
```

(attempt to change a system hard coded parameter)

```
>add/?ER6_NOT SUPPORTED BY HARDWARE'cr''lf']
```

(the command is a legal command but it is not supported by the current hardware configuration)

```
>add/?ER9_HARDWARE NOT OPERABLE'cr''lf']
```

(error is issued when hardware prevented the system from carrying out the user's remote command request)

B.2.3 End Character

Each message is ended with a single character which signals the end of the message:

- “cr” Carriage return character for commands
- “]” End bracket for responses

B.3 System Configuration Commands

Commands and responses for setting the basic system parameters of uplink and downlink frequency and attenuation, for making an adjustment on the internal reference, and for disabling the RF output are as specified in the following paragraphs. Commands are included for setting and selecting programmed frequency and attenuation values, for locking out changes in settings, and for reading the status of settings.

B.3.1 Configuration Commands/Responses

| | | | |
|---------------------------------|---|---|---|
| Up Converter Frequency Select | Command Response Status Response | <add/UCF_nnnnn.n'cr' >add/UCF_nnnnn.n'cr''lf'] <add/UCF'cr' >add/UCF_nnnnn.n'cr''lf'] | Where nnnnn.n = 13750.0 to 14500.0 (in MHz, variable in 1 MHz steps) |
| Down Converter Frequency Select | Command Response Status Response | <add/DCF_nnnnn.n'cr' >add/DCF_nnnnn.n'cr''lf'] <add/DCF'cr' >add/DCF_nnnnn.n'cr''lf'] | Where nnnnn.n = 10950.0 to 12750.0 (in MHz, variable in 1 MHz steps) |
| RF Output | Command Response Status Response | <add/RF_xxx'cr' >add/RF_xxx'cr''lf'] <add/RF_'cr' >add/RF_xxx'cr''lf'] | Where xxx = ON, WRM, OFF, default = OFF The OFF command will keep the RF output turned off under all conditions. The WRM command is a conditional ON command telling the RF output to come on after the unit is warmed up and meets the stability requirements. The ON command is an override instructing the output to be on and ignores the warm start. |
| Up Converter Attenuation | Command Response Status Response | <add/UCA_nn.n'cr' >add/UCA_nn.n'cr''lf'] <add/UCA_'cr' >add/UCA_nn.n'cr''lf'] | Where nn.n = 0.0 to 25.0 (in dB, variable in 1.0 dB steps) Note: No decimal point is displayed when UAGC is OFF and the UCA range is extended to 55 dB. |
| Down Converter Attenuation | Command Response Status Response | <add/DCA_nn.n'cr' >add/DCA_nn.n'cr''lf'] <add/DCA_'cr' >add/DCA_nn.n'cr''lf'] | Where nn.n = 0.0 to 20.0 (in dB, variable in 1.0 dB steps) |
| Select Preset Configuration | Command Response Status Response | <add/SEL_n'cr' >add/SEL_n'cr''lf'] <add/SEL_'cr' >add/SEL_'cr' 1'cr' UCF_nnnnn.n'cr' DCF_nnnnn.n'cr' UCA_nn.n'cr' DCA_nn.n'cr' 'cr' 2'cr' UCF_nnnnn.n'cr' DCF_nnnnn.n'cr' UCA_nn.n'cr' DCA_nn.n'cr' 'cr' 3'cr' UCF_nnnnn.n'cr' DCF_nnnnn.n'cr' UCA_nn.n'cr' DCA_nn.n'cr''lf'] | Where: n = 1, 2, or 3 nnnnn.n = 13750.0 to 14500.0 MHz (UC frequency) nnnnn.n = 10950.0 to 12750.0 MHz (DC frequency) nn.n = 0.0 to 25.0 dB (UC attenuation) nn.n = 0.0 to 20.0 dB (DC attenuation) or "None" if a configuration does not exist in that particular preset location. Allows the user to select any one of three "PreSet" configurations. The users must first program (STORE) a configuration using the PGM_n command. This command used without the "PreSet" number (n) will provide the current programming of each of the three "PreSet" configurations. The PGM_ and SEL_ pair of remote commands are similar to a "Save" and "Recall" pair of commands. UC and DC frequency and attenuation data are "saved" at the user's discretion and "recalled" for use at a later time. |

| | | | |
|------------------------------------|------------------|---|---|
| Program Preset Configuration | Command Response | <add/PGM_n'cr' >add/PGM_n'cr''lf'] | Where: n = 1, 2, or 3 xxxxxxx = "Programmed" or "None" |
| | Status Response | <add/PGM_'cr' >add/PGM_n'cr' 1 - xxxxxxxx'cr' 2 - xxxxxxxx'cr' 3 - xxxxxxxx'cr''lf'] | Allows the user to store (program) the current Up Converter and Down Converter frequency and attenuator settings as one of the three "PreSet" selections. Ref: SEL_ command for additional information. |
| Clear Program Preset Configuration | Command Response | <add/CPGM_n'cr' >add/CPGM_n'cr''lf'] | Where: n = 1, 2 or 3 xxxxxxx = "Programmed" or "None" |
| | Status Response | <add/CPGM_'cr' >add/CPGM_'cr' 1 - xxxxxxxx'cr' 2 - xxxxxxxx'cr' 3 - xxxxxxxx'cr''lf'] | Allows the user to clear (unprogram) the frequency and attenuator setting for one of the three "PreSet" selections. |
| Select Receive Band | Command Response | <add/SRB_n'cr' >add/SRB_n'cr''lf'] | Where: n = (A) for selecting frequency band 10950.0 to 11700.0 MHz inclusive. (B) for selecting frequency band 11700.0 to 12200.0 MHz inclusive. (C) for selecting frequency band 12250.0 to 12750.0 MHz inclusive. |
| | Status Response | <add/SRB_'cr' >add/SRB_n'cr''lf'] | Note: This command will not be recognized for the KST-2000A. It will only be recognized for the KST-2000B. |

B.3.2 System Configuration Commands

| | | | |
|----------------------------|------------------|---|--|
| Lock Mode | Command Response | <add/LM_xx'cr' >add/LM_xx'cr''lf'] | Where: LM = LK (Lock) or DS (Disable), Default = DS |
| | Status Response | <add/LM_'cr' >add/LM_xx'cr''lf'] | |
| Address Select | Command Response | <add/AS_xxx'cr' >add/AS_xxx'cr''lf'] | Where: add = Present Address xxx = New Address Default: Address = 1 |
| | Status Response | <add/AS_'cr' >add/AS_xxx'cr''lf'] | |
| Baud Rate Select | Command Response | <add/BR_xxxxx'cr' >add/BR_xxxxx'cr''lf'] | Where: xxxxx = 300, 600, 1200, 2400, 4800, 9600, or 19200 Default = 9600 |
| | Status Response | <add/BR_'cr' >add/BR_xxxxx'cr''lf'] | |
| Parity Select | Command Response | <add/PS_xx'cr' >add/PS_xx'cr''lf'] | Where: xx = OD (Odd), EV (Even) or NO (None) Default = EV (Even) Note: Selecting ODD or EVEN parity programs the KST-2000A to respond to 7,O,2 or 7,E,2 data formats. Selecting parity = NONE will set the KST-2000A to 8,N,1. |
| | Status Response | <add/PS_'cr' >add/PS_xx'cr''lf'] | |
| Reference Frequency Adjust | Command Response | <add/RFJ_nnn'cr' >add/RFJ_nnn'cr''lf'] | Where: nnn = Current DAC setting from 0 to 255 |
| | Status Response | <add/RFJ_'cr' >add/RFJ_nnn'cr''lf'] | Fine tunes the internal 10MHz high stability reference oscillator. |
| LNA or LNB Calibration | Command Response | <add/CLNAB_'cr' >add/CLNAB_'cr''lf'] | Note: This only needs to be done once during the initial installation. It calibrates the unit to determine the normal LNA or LNB power consumption. |
| LNA or LNB Fault Enable | Command Response | <add/LFE_xxx'cr' >add/LFE_xxx'cr''lf'] | Where: xxx= ON/OFF, Default is ON |
| | Status Response | <add/LFE_'cr' >add/LFE_xxx'cr''lf'] | Note: States whether or not the system should take action upon any, or report any, LNA or LNB fault notifications. |

| | | | |
|---------------------------------------|---|--|---|
| External Fault Enable | Command Response Status Response | <add/XFE_XXX'cr' >add/XFE_XXX'cr''lf'] <add/XFE_'cr' >add/XFE_XXX'cr''lf'] | Where: xxx= ON/OFF Default is ON Note: States whether or not the system should take action upon any, or report any, HPA, TWTA, SSPA fault notification. |
| HPA Power Enable | Command Response Status Response | <add/HPE_XXX'cr' >add/HPE_XXX'cr''lf'] <add/HPE_'cr' >add/HPE_XXX'cr''lf'] | Where: xxx = ON/OFF Default is OFF Note: For Comtech EF Data SSPA only, which turns ON/Off DC voltage supplied to HPA. |
| LNA or LNB Power Enable | Command Response Status Response | <add/LPE_XXX'cr' >add/LPE_XXX'cr''lf'] <add/LPE_'cr' >add/LPE_XXX'cr''lf'] | Where: xxx = ON/OFF Default is OFF |
| Transmit IF Output Power-up Condition | Command Response Status Response | <add/TXPU_XXXX'cr' >add/TXPU_XXXX'cr''lf'] <add/TXPU_'cr' >add/TXPU_XXXX'cr''lf'] | Where: XXXX = Last or OFF where Last = last known state, OFF = OFF This command selects the state that the TX-IF Output will be at power-up. |
| HPA Fault Polarity* | Command Response Status Response | <add/HFP_XX'cr' >add/HFP_XX'cr''lf'] <add/HFP_'cr' >add/HFP_XX'cr''lf'] | Where: XX = HI or LO This command informs the M&C which polarity is to be considered a fault when reading the HPA fault line. * Command/response is valid only when used with an Avantek 25W HPA. |

B.3.3 Reset Commands

| | | | |
|------------------------------------|---|--|---|
| Reset Redundancy Faults | Command Response | <add/RRF_'cr' >add/RRF_'cr''lf'] | Note: Resets/clears any detected redundancy faults. This command is intended to be used with a redundant system that was decided to be disassembled into a single-thread system. Improper disassembly will cause the M&C to report certain redundancy faults. By supplying this command the user will be notifying the M&C that the system will no longer be a redundant system and those faults should be reset. |
| Up Converter Latched Fault Reset | Command Response Status Response | <add/ULR_RESET'cr' >add/ULR_RESET'cr''lf'] <add/ULR_'cr' >add/ULR_'cr' LSSYN_XXX'cr' LKSYN_XXX'cr''lf'] | Note: Resets/clears any detected faults (Reset occurs on power up). Latched S-Band Synthesizer Lock Detect (OK/FLT) Latched Ku-Band Synthesizer Lock Detect (OK/FLT) |
| Down Converter Latched Fault Reset | Command Response Status Response | <add/DLR_RESET'cr' >add/DLR_RESET'cr''lf'] <add/DLR_'cr' >add/DLR_'cr' LLSYN_XXX'cr' LKSYN_XXX'cr''lf'] | Note: Resets/clears any detected faults (Reset occurs on power up). Latched L-Band Synthesizer Lock Detect (OK/FLT) Latched Ku-Band Synthesizer Lock Detect (OK/FLT) |
| M&C Soft Reset | Command Response | <add/SRM_'cr' | Note: All current variables are retained, as system restarts. |
| M&C Hard Reset | Command Response | <add/HRM_'cr' | Note: All current variables will be updated to default values. |
| UC Automatic Gain Control | Command Response | <add/UAGC_XXX'cr' >add/UAGC_XXX'cr''lf'] | Where: XXX = ON/OFF Default = OFF on "cold start" or "hard reset" UAGC will be set to the last programmed state on subsequent power cycles. On will enable UC automatic gain control. OFF will disable UC automatic gain control. Note: Disabling UAGC will cause the UC attenuation to be displayed as an integer (without a decimal point). |

B.3.4 Status Commands/Responses

| | | | |
|-----------------------------|------------------|---|---|
| System Configuration Status | Command Response | <add/OS_'cr' >add/OS_'cr' UCF_nnnnn.n'cr' DCF_nnnnn.n'cr' RF_XXX'cr' UCA_nn.n'cr' DCA_nn.n'cr' SEL_n'cr''lf'] | Where: nnnnn.n = 13750.0 to 14500.0 MHz nnnnn.n = 10950.0 to 12750.0 MHz xxx = ON, WRM or OFF nn.n = 0.0 to 25.0 dB nn.n = 0.0 to 20.0 dB n = 1, 2, 3, or None The converter configuration status command causes a block of data to be returned by the addressed KST-2000A/B. The block of data reflects the current configuration status. |
| System Fault Status | Command Response | <add/FS_'cr' >add/FS_'cr' US_XXX'cr' HS_XXX'cr' DS_XXX'cr' RS_XXX'cr' AGS_XXX'cr' LS_XXX'cr' CES_XXX'cr''lf'] | Up Converter Faults (OK/FLT) HPA Faults (OK/FLT) Down Converter Faults (OK/FLT) Reference Faults (OK/FLT) AGC Faults (OK/FLT) LNA Faults (OK/FLT) Common Equipment Faults (OK/FLT) |

| | | | |
|--|------------------|--|---|
| System Maintenance Status | Command Response | <add/MS_`cr` >add/MS_`cr` UCT_nn`cr` HPT_nn`cr` DCT_nn`cr` MCT_nn`cr` PRF_nn`cr` FTD_xxx`cr` HV_xxx`cr`'lf`] | Where: nn = UC Temperature in °C nn = HPA Temperature in °C nn = DC Temperature in °C nn = M&C Temperature in °C nn = Comtech EF Data HPA corrected RF output power N/A = OEM SSPA N/A = OEM TWTA xxx = (OK/DLY or N/A) OEM TWTA only, Heater timer complete xxx = ON/OFF or N/A OEM TWTA only, high voltage status |
| Up Converter Current Faults | Command Response | <add/US_`cr` >add/US_`cr` RF_xxx`cr` UC_xxx`cr` SSYN_xxx`cr` KSYN_xxx`cr` LSSYN_xxx`cr` LKSYN_xxx`cr` PROG_xxx`cr` SFLT_#`cr`'lf`] | RF Output (ON/OFF) Actual Status Up Converter Module (OK/FLT) S-Band Synthesizer Lock Detect (OK/FLT) Ku-Band Synthesizer Lock Detect (OK/FLT) Latched S-Band Synthesizer Lock Detect (OK/FLT) Latched Ku-Band Synthesizer Lock Detect (OK/FLT) Inter-processor Communications (OK/FLT) Number of stored faults (# = 1 to 10) |
| HP Current Faults 2 and 4 Watt SSPAs Current Faults (Comtech EF Data) | Command Response | <add/HS_`cr` >add/HS_`cr` RF_xxx`cr` HPA_xxx`cr` BV1_xxx`cr` +9.75V_xxx`cr` -5V_xxx`cr` PROG_xxx`cr` SFLT_#`cr`'lf`] | RF Output (ON/OFF) Actual Status HPA Converter Module (OK/FLT) Bias Voltage #1 (OK/FLT) +9.75 V Power Supply (OK/FLT) -5 Volt Power Supply (OK/FLT) Inter-processor Communications (OK/FLT) Number of stored faults (# = 1 to 10) |
| HP Current Faults 8 Watt SSPAs Current Faults (Comtech EF Data) | Command Response | <add/HS_`cr` >add/HS_`cr` RF_xxx`cr` HPA_xxx`cr` BV1_xxx`cr` BV2_xxx`cr` BV3_xxx`cr` +9.75V_xxx`cr` -5V_xxx`cr` PROG_xxx`cr` SFLT_#`cr`'lf`] | RF Output (ON/OFF) Actual Status HPA Converter Module (OK/FLT) Bias Voltage #1 (OK/FLT) Bias Voltage #2 (OK/FLT) Bias Voltage #3 (OK/FLT) +9.75 V Power Supply (OK/FLT) -5 Volt Power Supply (OK/FLT) Inter-processor Communications (OK/FLT) Number of stored faults (# = 1 to 10) |
| HP Current Faults 16 Watt SSPAs Current Faults (Comtech EF Data) | Command Response | <add/HS_`cr` >add/HS_`cr` RF_xxx`cr` HPA_xxx`cr` BV1_xxx`cr` BV2_xxx`cr` BV3_xxx`cr` BV4_xxx`cr` BV5_xxx`cr` +9.75V_xxx`cr` -5V_xxx`cr` PROG_xxx`cr` SFLT_#`cr`'lf`] | RF Output (ON/OFF) Actual Status HPA Converter Module (OK/FLT) Bias Voltage #1 (OK/FLT) Bias Voltage #2 (OK/FLT) Bias Voltage #3 (OK/FLT) Bias Voltage #4 (OK/FLT) Bias Voltage #5 (OK/FLT) +9.75 V Power Supply (OK/FLT) -5 Volt Power Supply (OK/FLT) Inter-processor Communications (OK/FLT) Number of stored faults (# = 1 to 10) |

| | | | |
|--|--------------------------|---|--|
| <p>HP Current Faults 25, 32, and 40 Watt SSPAs Current Faults (Comtech EF Data)</p> | <p>Command Response</p> | <p><add/HS_`cr` >add/HS_`cr` RF_`xxx`cr` HPA_`xxx`cr` BV1_`xxx`cr` BV2_`xxx`cr` BV3_`xxx`cr` BV4_`xxx`cr` BV5_`xxx`cr` BV6_`xxx`cr` BV7_`xxx`cr` BV8_`xxx`cr` BV9_`xxx`cr` +9.75V_`xxx`cr` -5V_`xxx`cr` PROG_`xxx`cr` SFLT_`#`cr`lf`]</p> | <p>RF Output (ON/OFF) Actual Status HPA Converter Module (OK/FLT) Bias Voltage #1 (OK/FLT) Bias Voltage #2 (OK/FLT) Bias Voltage #3 (OK/FLT) Bias Voltage #4 (OK/FLT) Bias Voltage #5 (OK/FLT) Bias Voltage #6 (OK/FLT) Bias Voltage #7 (OK/FLT) Bias Voltage #8 (OK/FLT) Bias Voltage #9 (OK/FLT) +9.75 V Power Supply (OK/FLT) -5 Volt Power Supply (OK/FLT) Inter-processor Communications (OK/FLT) Number of stored faults (# = 1 to 10)</p> |
| <p>Note: The following responses are from an OEM SSPA only:</p> <p>HPA_`xxx`cr` HPA Converter Module (OK/FLT) _`##`cr`lf`] Number of stored faults (# = 0 to 9)</p> <p>The following responses are from an OEM TWTA only:</p> <p>HPA_`xxx`cr` HPA Converter Module (OK/FLT) TEMP_`xxx`cr` Temperature (ON/FLT) HV_`xxx`cr` High voltage (ON/FLT) SFLT_`##`cr`lf`] Number of stored faults (# = 0 to 9)</p> | | | |
| <p>Down Converter Current Faults</p> | <p>Command Response</p> | <p><add/DS_`cr` >add/DS_`cr` DC_`xxx`cr` LSYN_`xxx`cr` KSYN_`xxx`cr` LLSYN_`xxx`cr` LKSYN_`xxx`cr` PROG_`xxx`cr` SFLT_`#`cr`lf`]`</p> | <p>Down Converter Module (OK/FLT) L-Band Synthesizer Lock Detect (OK/FLT) Ku-Band Synthesizer Lock Detect (OK/FLT) Latched L-Band Synthesizer Lock Detect (OK/FLT) Latched Ku-Band Synthesizer Lock Detect (ON/FLT) Inter-processor Communications (OK/FLT) Number of stored faults (# = 1 to 10)</p> |
| <p>Reference Current Faults</p> | <p>Command Response</p> | <p><add/RS_`cr` >add/RS_`cr` REF_`xxx`cr` 72MHz_`xxx`cr` OSC_`xxxx`cr`lf`]` SFLT_`#`cr`lf`]`</p> | <p>Reference Actual Status (INT/EXT) 72 MHz Lock Detect (OK/FLT) Restart_condition/heater (WARM/COLD) Number of stored faults (# = 1 to 10)</p> |
| <p>Common Equipment Current Faults</p> | <p>Command Response</p> | <p><add/CES_`cr` >add/CES_`cr` M&C_`xxx`cr` -7V_`xxx`cr` +7V_`xxx`cr` +12V_`xxx`cr` +17V_`xxx`cr` TXS_`xxx`cr` RXS_`xxx`cr` IFS_`xxx`cr` RFLC_`xxx`cr` SFLT_`#`cr`lf`]`</p> | <p>M&C Module (OK/FLT) -7 volt power supply (OK/FLT) +7 volt power supply (OK/FLT) +12 volt power supply (OK/FLT) +17 volt power supply (OK/FLT) TX Redundancy Switch (OK/FLT) RX Redundancy switch (OK/FLT) IF Redundancy Switch (OK/FLT) Redundancy Fault Line Cable (OK/FLT) Number of stored faults (# = 1 to 10)</p> |
| <p>LNA Current Faults</p> | <p>Command Response:</p> | <p><add/LS_`cr` >add/LS_`cr` LNA_`xxx`cr` SFLT_`#`cr`lf`]`</p> | <p>LNA module fault (OK/FLT) Number of stored faults (# = 0 thru 9)</p> |

| | | | |
|--------------------|------------------|---|--|
| AGC Current Faults | Command Response | <add/AGS_#’cr’ >add/AGS_#’cr’ EIP_XXX’cr’ IIP_XXX’cr’ LOOP_XXX’cr’ SFLT_#’cr’lf’ | Where: (# = 1 to 10) ASF_# NO FAULT or Excessive Input Power Fault (OK/FLT) Insufficient Input Power Fault (OK/FLT) AGC Loop Converge Fault (OK/FLT) Number of stored faults (# - 0 thru 9) |
|--------------------|------------------|---|--|

B.3.5 Stored Faults

Information on stored faults is returned when requested. If no stored fault exists for a given fault number the words, “NO_FAULT” will be returned in lieu of the normal fault status information.

The following symbols are commonly used to define the stored faults status commands:

- ‘#’ Fault Number (0 to 9)
- ‘0’ is the first fault stored

| | | | |
|---------------------------------|------------------|---|--|
| Clear Stored Faults | Command Response | <add/CLSF_’cr’ >add/CLSF_’cr’lf’] | Note: This clears all stored faults of all modules. |
| Up Converter Stored Faults | Command Response | <add/USF_#’cr’ >add/USF_#’cr’lf’] RF_XXX’cr’ UC_XXX’cr’ SSYN_XXX’cr’ KSYN_XXX’cr’ LSSYN_XXX’cr’ LKSSYN_XXX’cr’ PROG_XXX’cr’lf’] | Where # = 0 to 9 USF_# NO_FAULT or RF Output (ON/OFF) Actual Status Up Converter Module (OK/FLT) S-Band Synthesizer Lock Detect (OK/FLT) Ku-Band Synthesizer Lock Detect (OK/FLT) Latched S-Band Synthesizer Lock Detect (OK/FLT) Inter-Processor Communications (OK/FLT) |
| 2 and 4 Watt SSPA Stored Faults | Command Response | <add/HSF_#’cr’ >add/HSF_#’cr’ RF_YYY’cr’ HPA_XXX’cr’ BV1_XXX’cr’ +9.75V_XXX’cr’ -5V_XXX’cr’ PROG_XXX’cr’ SFLT_#’cr’lf’] | Where: # = 0 to 9 HSF_# NO_FAULT or RF Output (ON/OFF) Actual Status HPA Converge Module (OK/FLT) Bias Voltage #1 (OK/FLT) +9.75 Volt power Supply (OK/FLT) -5 Volt Power Supply (OK/FLT) Inter-Processor Communications (OK/FLT) Number of Stored Faults (# = 0 to 10) The following response is from an OEM SSPA only: HPA_XXX’cr’ HPA Converter Module (OK/FLT) The following responses are from an OEM TWTA only: HPA_XXX’cr’ HPA Converter Module (OK/FLT) TEMP_XXX’cr’ Temperature (OK/FLT) HV_XXX’cr’ High Voltage (ON/OFF) |

| | | | |
|--|-----------------------------|--|---|
| <p>8 Watt SSPAs Stored Faults</p> | <p>Command Response</p> | <p><add/HSF_#’cr’ >add/HSF_#’cr’ RF_yyy’cr’ HPA_xxx’cr’ BV1_xxx’cr’ BV2_xxx’cr’ BV3_xxx’cr’ +9.75V_xxx’cr’ -5V_xxx’cr’ PROG_xxx’cr’lf’] SFLT_#’cr’lf’]</p> | <p>Where: # = 0 to 9 HSF_# NO_FAULT or RF Output (ON/OFF) Actual Status HPA Converge Module (OK/FLT) Bias Voltage #1 (OK/FLT) Bias Voltage #2 (OK/FLT) Bias Voltage #3 (OK/FLT) +9.75 Volt power Supply (OK/FLT) -5 Volt Power Supply (OK/FLT) Inter-Processor Communications (OK/FLT) Number of Stored Faults (# = 0 to 10)</p> <p>The following response is from an OEM SSPA only: HPA_xxx’cr’ HPA Converter Module (OK/FLT)</p> <p>The following responses are from an OEM TWTA only: HPA_xxx’cr’ HPA Converter Module (OK/FLT) TEMP_xxx’cr’ Temperature (OK/FLT) HV_xxx’cr’ High Voltage (ON/OFF)</p> |
| <p>16 Watt SSPAs Stored Faults</p> | <p>Command Response</p> | <p><add/HSF_#’cr’ >add/HSF_#’cr’ RF_yyy’cr’ HPA_xxx’cr’ BV1_xxx’cr’ BV2_xxx’cr’ BV3_xxx’cr’ BV4_xxx’cr’ BV5_xxx’cr’ +9.75V_xxx’cr’ -5V_xxx’cr’ PROG_xxx’cr’ SFLT_#’cr’lf’]</p> | <p>Where: # = 0 to 9 HSF_# NO_FAULT or RF Output (ON/OFF) Actual Status HPA Converge Module (OK/FLT) Bias Voltage #1 (OK/FLT) Bias Voltage #2 (OK/FLT) Bias Voltage #3 (OK/FLT) Bias Voltage #4 (OK/FLT) Bias Voltage #5 (OK/FLT) +9.75 Volt power Supply (OK/FLT) -5 Volt Power Supply (OK/FLT) Inter-Processor Communications (OK/FLT) Number of Stored Faults (# = 0 to 10)</p> <p>The following response is from an OEM SSPA only: HPA_xxx’cr’ HPA Converter Module (OK/FLT)</p> <p>The following responses are from an OEM TWTA only: HPA_xxx’cr’ HPA Converter Module (OK/FLT) TEMP_xxx’cr’ Temperature (OK/FLT) HV_xxx’cr’ High Voltage (ON/OFF)</p> |

| | | | |
|--------------------------------------|---------------------|---|--|
| 25/32/40 Watt SSPAs Stored Faults | Command Response | <add/HSF_#’cr’ >add/HSF_#’cr’ RF_yyy’cr’ HPA_xxx’cr’ BV1_xxx’cr’ BV2_xxx’cr’ BV3_xxx’cr’ BV4_xxx’cr’ BV5_xxx’cr’ BV6_xxx’cr’ BV7_xxx’cr’ BV8_xxx’cr’ BV9_xxx’cr’ +9.75V_xxx’cr’ -5V_xxx’cr’ PROG_xxx’cr’ SFLT_#’cr’]f’] | Where: # = 0 to 9 HSF_# NO_FAULT or RF Output (ON/OFF) Actual Status HPA Converge Module (OK/FLT) Bias Voltage #1 (OK/FLT) Bias Voltage #2 (OK/FLT) Bias Voltage #3 (OK/FLT) Bias Voltage #4 (OK/FLT) Bias Voltage #5 (OK/FLT) Bias Voltage #6 (OK/FLT) Bias Voltage #7 (OK/FLT) Bias Voltage #8 (OK/FLT) Bias Voltage #9 (OK/FLT) +9.75 Volt power Supply (OK/FLT) -5 Volt Power Supply (OK/FLT) Inter-Processor Communications (OK/FLT) Number of Stored Faults (# = 0 to 10) The following response is from an OEM SSPA only: HPA_xxx’cr’ HPA Converter Module (OK/FLT) The following responses are from an OEM TWTA only: HPA_xxx’cr’ HPA Converter Module (OK/FLT) TEMP_xxx’cr’ Temperature (OK/FLT) HV_xxx’cr’ High Voltage (ON/OFF) |
| Down Converter Stored Faults | Command Response | <add/DSF_#’cr’ >add/DSF_#’cr’]f’] DC_xxx’cr’ LSYN_xxx’cr’ KSYN_xxx’cr’ LLSYN_xxx’cr’ LKSYN_xxx’cr’ PROG_xxx’cr’]f’] | Where # = 0 to 9 DSF_# NO_FAULT or Down Converter Module (OK/FLT) L-Band Synthesizer Lock Detect (OK/FLT) Ku-Band Synthesizer Lock Detect (OK/FLT) Latched L-Band Synthesizer Lock Detect (OK/FLT) Latched Ku-Band Synthesizer Lock Detect (OK/FLT) Inter-Processor Communications (OK/FLT) |
| Common Equipment Stored Faults | Command Response | <add/CSF_#’cr’ >add/CSF_#’cr’]f’] M&C_xxx’cr’ -7V_xxx’cr’ +7V_xxx’cr’ +12V_xxx’cr’ +17V_xxx’cr’ TXS_xxx’cr’ RXS_xxx’cr’ IFS_xxx’cr’ RFLC_xxx’cr’]f’] | Where # = 0 to 9 CSF_# NO_FAULT or M&C Module (OK/FLT) -7 Volt Power Supply (OK/FLT) +7 Volt Power Supply (OK/FLT) +12 Volt Power Supply (OK/FLT) +17 Volt Power Supply (OK/FLT) TX Redundancy Switch (OK/FLT) RX Redundancy Switch (OK/FLT) IF Redundancy Switch (OK/FLT) Redundancy Fault Line Cable (OK/FLT) |
| Reference Stored Faults | Command Response | <add/RSF_#’cr’ >add/RSF_#’cr’]f’] REF_xxx’cr’ LOCK_xxx’cr’ PHASE_xxx’cr’ RANGE_xxx’cr’ 72MHz_xxx’cr’ OSC_xxx’cr’]f’] | Where # = 0 to 9 RSF_# NO_FAULT or Reference Actual Status (INT/EXT) If EXT 10 MHz Lock Detect If EXT (OK/FLT) If EXT (OK/FLT) 72MHz Lock Detect (OK/FLT) Restart Condition Heater (WRM/ON) |
| LNA Stored Faults | Command Response | <add/LSF_#’cr’ >add/LSF_#’cr’ LNA_xxx’cr’]f’] | Where: (# = 1 to 10) LSF_# NO_FAULT or LNA module fault (OK/FLT) |
| AGC Stored Faults | Command Response | <add/ASF_#’cr’ >add/ASF_#’cr’ EIP_xxx’cr’ IIP_xxx’cr’ LOOP_xxx’cr’]f’] | Where: (# = 1 to 10) ASF_# NO_FAULT or Excessive Input Power Fault (OK/FLT) Insufficient Input Power Fault (OK/FLT) AGC Loop Converge Fault (OK/FLT) |

B.3.6 Miscellaneous

| | | | |
|--|---|--|---|
| Monitor and Control Firmware Information | Command Response | <add/MCFI_`cr` >add/MCFI_`cr` VER_xxx.yyy.zzz`cr` FW/nnnnn-ddr`cr` mm/dd/yy`cr`lf`] | Where: xxx.yyy.zzz = Software version number (0.0.0 to 999.999.999) nnnnn = Firmware number (0 to 99999) dd = Firmware dash number (0 to 99) r = Firmware revision (-, or A to Z) |
| Up Converter Firmware Information | Command Response | <add/UFI_`cr` >add?UFI_`cr` VER_xxx.yyy.zzz`cr` FW/nnnnn-ddr`cr` mm/dd/yy`cr`lf`] | Where: xxx.yyy.zzz = Software version number (0.0.0 to 999.999.999) nnnnn = Firmware number (0 to 99999) dd = Firmware dash number (0 to 99) r = Firmware revision (-, or A to Z) |
| Down Converter Firmware Information | Command Response | <add/DFI_`cr` >add/DFI_`cr` VER_xxx.yyy.zzz`cr` FW/nnnnn-ddr`cr` mm/dd/yy`cr`lf`] | Where: xxx.yyy.zzz = Software version number (0.0.0 to 999.999.999) nnnnn = Firmware number (0 to 99999) dd = Firmware dash number (0 to 99) r = Firmware revision (-, or A to Z) |
| HPA Firmware Information | Command Response | <add/HFI_`cr` >add/HFI_`cr` VER_xxx.yyy.zzz`cr` FW/nnnnn-ddr`cr` mm/dd/yy`cr`lf`] | Where: xxx.yyy.zzz = Software version number (0.0.0 to 999.999.999) nnnnn = Firmware number (0 to 99999) dd = Firmware dash number (0 to 99) r = Firmware revision (-, or A to Z) |
| Query Serial Numbers | Status Response | <add/SNUM_`cr` >add/SNUM_`cr` UC_xxxxxxxxx`cr` HPA_xxxxxxxxx`cr` DC_xxxxxxxxx`cr` M&C_xxxxxxxxx`cr`lf`] | Where: xxxxxxxxxx = Serial Number (0 to 999999999) |
| Query Assembly Numbers | Command Response | <add/ANUM_`cr` >add/ANUM_`cr` UC_AS/nnnnn-ddr`cr` HPA_AS/nnnnn-ddr`cr` DC_AS/nnnnn-ddr`cr` M&C_AS/nnnnn-ddr`cr`lf`] | Where: nnnnn = Assembly number (0 to 99999) d = Dash number (0 to 9) r = Revision (-, or A to Z) |
| TWTA Heater | Command Response Status Response | <add/HTR_xxx`cr` >add/HTR_xxx`cr`lf`] <add/HTR_`cr` >add/HTR_xxx`cr`lf`] | Where: xxx = WRM or HOT Default = HOT or N/A if TWTA is not HPA type |
| TWTA Fault Reset | Command Response | <add/TWTR_`cr` >add/TWTR_RESET`cr`lf`] | Note: This clears out any existing faults for a connected TWTA. |
| Equipment Type | Command Response | <add/ET_`cr` >add/ET_ttttttt_xxx.yyy.zzz`cr`lf`] Example: >1/ET_KST-2000A_1.1.1 | Where: tttttttt = Equipment Type xxx.yyy.zzz = Software Version |
| HPA Connector Location | Command Response | <add/HCL2_`cr` >add?HCL2_xxx`cr`lf`] | Where: CEFD-SSPA OEM-SSPA OEM-TWTA N/C (Not Connected) This command returns the current location of the SSPA M&C cable. |

| | | | |
|--------------------|------------------|---|--|
| Burst Control Mode | Command Response | <add/BCM_XXX'cr' >add/BCM_XXX'cr''lf'] | Where: xxx = ON or OFF Default = OFF This command enters a special burst signal operation mode, when Uplink AGC is disabled. The detected loss of an IF input carrier will cause the uplink to turn its RF OFF. When the IF carrier is re-applied, the RF will be turned ON. |
| | Status Response | <add/BCM_'cr' >add/BCM_XXX'cr''lf'] | |

B.4 Backup Operations/Self-Contained Redundancy

| | | | |
|-------------------|------------------|---|--|
| Backup Operations | Command Response | <add/BACK_XXX'cr' >add/BACK_XXX'cr''lf'] | Where: xxx = YES, which forces the unit to become aware that another K8 device needs to be considered for backup situations when faults occur. NO , (Default), which forces the unit to realize it is the only K8 used in communications. |
| | Status Response | <add/BACK_'cr' >add/BACK_XXX'cr''lf'] | |
| Backup Mode | Command Response | <add/BM_XXXXXXX'cr' >add/BM_XXXXXXX'cr''lf'] | Where: xxxx = AUTO-IND, which forces the unit to automatically switch from an OFFLINE mode to an ONLINE mode depending upon whether or not a fault has occurred in the other unit. It forces the unit to independently relinquish control of either the UL or DL when a fault occurs in that specific link. When a fault occurs on a link for one unit the other unit will pick up control of the specific link. AUTO-DEP, which forces the unit to automatically switch from an OFFLINE mode to an ONLINE mode depending upon whether or not a fault has occurred in the other unit. It forces the unit to relinquish control of both the UL and DL when a fault occurs on either link. The other unit will pick up control of both the UL and DL when this occurs. MANUAL, (Default) which forces the unit to switch from an OFFLINE mode to an ONLINE mode regardless of what the other is doing. The switching is respective to the manual operation which the user set with the BMO_ command. Notes: 1. When switching from automatic modes into manual mode the position of the switches remain the same and the ONLINE/OFFLINE status remains unchanged until the BMO_ command is issued. 2. When switching from manual mode into an automatic mode the position of the switches remain unchanged and the specific link which corresponds to the position of the switch(es) will take the ONLINE status. Hence, the orientation of the switches will configure the initial OFFLINE/ONLINE status of the automatic modes of operation. 3. When a link is manually forced ONLINE that link will remain ONLINE until; the user changes the state of that link with another manual command; or the firmware notices the switches that are involved are no longer in the correct position for that link. |
| | Status Response | <add/BM_'cr' >add/BM_XXXXXXX'cr''lf'] | |

| | | | |
|-------------------------|------------------|---|--|
| BackUp Manual Operation | Command Response | <add/BMO_XXX'cr' >add/BMO_XXX'cr''lf'] | Where: xxx = UL, which forces the unit to make the UL ONLINE and DL OFFLINE. DL, which forces the unit to make DL ONLINE and UL OFFLINE DLUL, which forces the unit to make the DL and the UL ONLINE. Note: This command only has meaning if the BM_ command set to MANUAL. |
| Backup Status | Status Response | <add/BS_'cr' >add/BS_'cr' UL_XXXXXX'cr' DL_XXXXXX'cr''lf'] | Where: xxxxxx = OFFLINE, which indicates the specific link is not under the influence of the machine that reported this status. xxxxxx = ONLINE, indicates the link is under the control of the machine that reported this status. Note: This command only has meaning if the BACK_ command is set to YES. |

B.4.1 External Fault Mode

| | | | |
|---------------------|------------------|---|---|
| External Fault Mode | Command Response | <add/XFM_XXX'cr' >add/XFM_XXX'cr''lf'] | Where: xxx = ON, which notifies the M&C control system that when the following conditions have been met to take special action: <ol style="list-style-type: none"> 1. If (the >25 Watt SSPA is connected to the M&C system) and 2. If (that >25 Watt SSPA signals an active summary fault) and 3. If (that fault is the only UL fault is the entire system) then 4. Perform normal redundant switching, however, Do Not Turn OFF the RF signal in the transceiver that senses the SSPA summary fault. OFF, which notifies the M&C control system that when any fault is incurred in the uplink from any source, that the system will perform normal redundant switching and it will turn OFF the RF signal in the transceiver that senses those faults. Note: This command must be issued to both redundancy units in order for this mode of operation to perform properly. |
| | Status Response | <ad/XFM_'cr' >add/XFM_XXX'cr''lf'] | |

B.5 Keypad/Display Related Commands

| | | | |
|--------------|------------------|---|--|
| Display Time | Command Response | <add/DT_XXX'cr' >add/DT_XXX'cr''lf'] | Where: xxx = is the time in seconds the display will stay on before blanking. The range of xxx is 10 to 999 seconds. |
| | Status Response | <add/DT_'cr' >add/DT_XXX'cr''lf'] | |

Appendix C. SINGLE-THREAD EQUIPMENT MOUNTING

This section describes the optional installation hardware and procedures for the following applications:

| Section | Installation Description |
|---------|---|
| C.1 | Tools required |
| C.2 | Converter installation: |
| C.2.1 | Spar arm mount |
| C.2.2 | Pole mount (round or square) |
| | Note: The converter unit can be installed anywhere on or near the antenna. |
| C.3 | SSPA installation |
| C.3.1 | For offset feed mount antenna |
| C.4 | LNA installation |
| C.4.1 | For offset feed mount antenna |
| C.5 | Cable installation |

Installation procedures and hardware kits have been verified on the following antennas:

- PRODELIN 1.8, 2.4, and 3.8M
- Channel Master offset antenna

Figure C-1 is an example of a single thread system installed on the antenna spar arm assembly.



Figure C-1. KST-2000A Single Thread System Installed on Spar Arm.

C.1 Tools Required

| Qty. | Description |
|------|---|
| 1 | 3/8" drive ratchet. |
| 1 | Adjustable wrench. |
| 1 | 7/16" x 3/8" drive socket, or 7/16" drive wrench. (Metric equivalent: 12mm, 6 pt.) |
| 1 | 1/2" x 3/8" drive socket, or 1/2" box wrench. (Metric equivalent: 13mm, 6 pt.) |
| 1 | 5/16" box wrench, or nut driver |
| 1 | 7/64" Allen wrench |





C.2 Converter Unit Installation





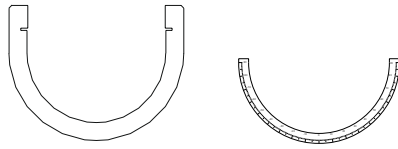

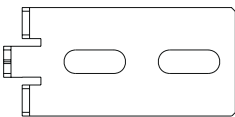

The following information describes the steps performed and optional hardware required for installing the converter unit on an antenna spar arm or a pole.

C.2.1 Spar Arm Mount

C.2.1.1 Optional Spar Arm Installation Kits for Converter, SSPA, and LNA

| Antenna Type Mounting Kit | Kit Part Number |
|---------------------------------------|-----------------|
| PRODELIN 5.25" Interface Mounting Kit | KT/7805-1 |
| PRODELIN 3.74" Interface Mounting Kit | KT/7945-1 |
| Channel Master Offset Mounting Kit | KT/7595-1 |

| Kits KT/7805, KT/7945, and KT/7595 include: | | (Continued on next page) | |
|---|---|--------------------------|--|
| Qty. | Description | Qty. | Description |
| 2 | Spar support bracket. (Spar Mount Only)  Comtech EFData Part #s: FP/3175 (included in KT/7805 & KT/7945) FP/7579-1 (included in KT/7595) | 1 | "U" Bracket and scale overlay  Comtech EFData Part #: FP/7569-1, and OL/7609-1 |
| 2 | 1/4-20 x 5/8" bolt.  Comtech EFData Part #: 03P1131 | 5 | 1/4-20 x 1" bolt.  Comtech EFData Part #: HW/ 1/4-20x1-BLT |
| 7 | 1/4" flat washer.  Comtech EFData Part #: HW/1/4-FLT. | 1 | Interface Bracket  Comtech EFData Part #s: FP/7936-1 (included in KT/7805 & KT/7595) FP/7937-1 (included in KT/7945) |

| (continued) Kits KT/7805, KT/7945, and KT/7595 include: | | | |
|---|---|------|--|
| Qty. | Description | Qty. | Description |
| 7 | 1/4" split washer.  <i>Comtech EFData Part #: HW/1/4-SPLIT.</i> | 1 | Spade head screw  <i>Comtech EFData Part #: HW/10-32x1/2SP</i> |
| 3 | 1/4-20 hex nut.  <i>Comtech EFData Part #: HW/5/16-18HEXNT.</i> | 2 | 5/16-16 x 3/4 bolt  <i>Comtech EFData Part #: HW/5/16-163/4B (included in KT/7595)</i> |
| 2 | 5/16" flat washer  <i>Comtech EFData Part #: HW/5/16-FLT (included in KT/7595)</i> | 2 | 5/16" split washer  <i>Comtech EFData Part #: HW/5/16-split (included in KT/7595)</i> |
| 2 | 5/16-16 Hex nut  <i>Comtech EFData Part #: HW/5/16-16 HEXNUT (included in KT/7595)</i> | 1 | LNA Installation Kit <i>Comtech EFData Part #: KT/2820</i> |
| 1 | Nut Plate  <i>Comtech EFData Part #: FP/7944-1 (included in KT/7595)</i> | | |

C.2.1.2 Converter Spar Arm Mounting Instructions

1. Position the Converter unit against the spar arm of the satellite dish and bolt the two spar support brackets to the Converter unit brackets as shown in Figure C-2. Utilize four each 1/4x-20x1" bolts, 1/4 split, and 1/4" flat washers.

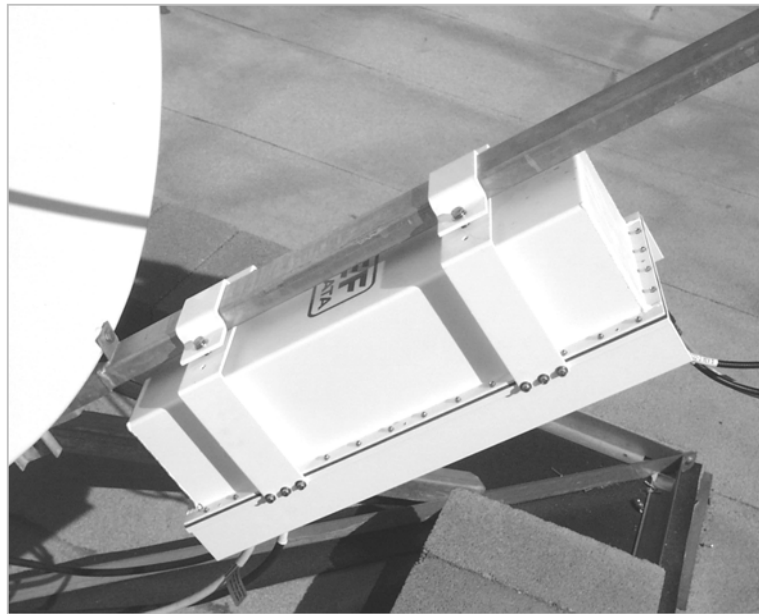









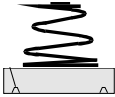



Figure C-2. Typical Converter Unit Installation on Spar

C.2.2 Pole Mount

C.2.2.1 Optional Pole Mount Installation Kit for Converter

| Kit KT/8094 includes: | | | |
|-----------------------|--|--|---|
| Qty. | Description | | Qty. Description |
| 4 | Unistrut — 14" long.  <i>Comtech EFData Part # FP/3595.</i> | | 8 5/16-18 x 1" bolt.  <i>Comtech EFData Part # HW/5/16-18X1BLT.</i> |
| 6 | 1/4-20 x 5/8" bolt.  <i>Comtech EFData Part # 03P1131. Used to attach Unistruts to RFT.</i> | | 20 5/16" split washer.  <i>Comtech EFData Part # HW/5/16-SPLIT.</i> |
| 6 | 1/4" flat washer.  <i>Comtech EFData Part # HW/1/4-FLT. Used to attach Unistruts to RFT.</i> | | 20 5/16" flat washer.  <i>Comtech EFData Part # HW/5/16-FLT.</i> |
| 6 | 1/4" split washer.  <i>Comtech EFData Part # HW/1/4-SPLIT. Used to attach Unistruts to RFT.</i> | | 12 5/16-18 hex nut.  <i>Comtech EFData Part # HW/5/16-18HEXNT.</i> |
| 8 | Pipe block.  <i>Comtech EFData Part # HW/BLK-PIPE2-8. Used for round pole mount only.</i> | | 12 5/16-18 spring nut.  <i>Comtech EFData Part # HW/5/16-18SPNUT.</i> |
| 4 | Threaded rod, 5/16-18 x 14".  <i>Comtech EFData Part # HW/RD5/16-18X14.</i> | | 8 Flat fitting plate, 5/16".  <i>Comtech EFData Part # HW/FIT-PLT-5/16.</i> |

C.2.2.2 Converter Round Pole Mounting Instructions

1. Position the converter with fins down and mounting brackets facing upward (refer to Figure C-3). Position (2) 14" Unistrut channels centered on the converter mounting brackets. Fasten with 1/4" hardware (4 to 6 each of bolts, split and flat washers).

Note: Vary the number and location of the hardware as needed to avoid interfering with the spring nuts used for the pipe blocks.

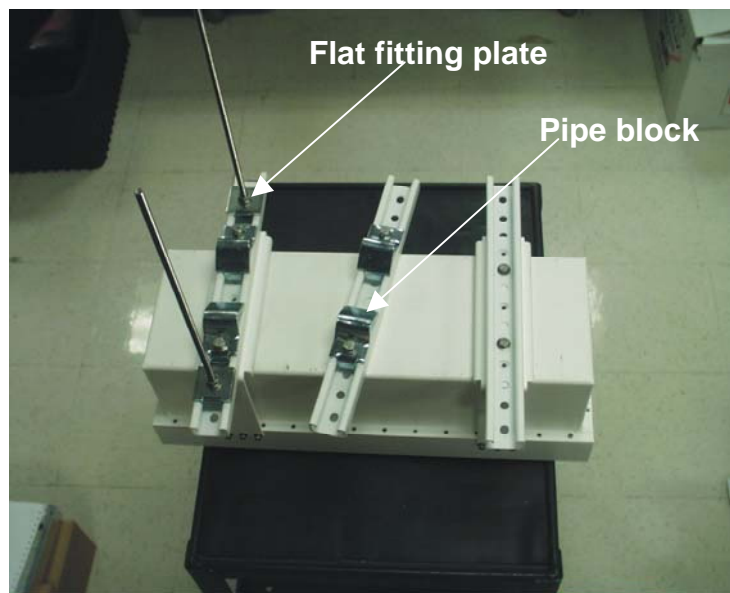

Figure C-3. KST-2000A Converter with Mounting Brackets

2. Position two spring nuts into the channel of one of the remaining Unistrut channels. With the mounting holes facing the ends of the channel, fasten two pipe blocks loosely to the spring nuts with the hardware (2 each 5/16" bolts, split and flat washers).
3. Place the channel with pipe blocks against the mounting pole, slide the pipe blocks until they contact the mounting pole. Ensure the pipe blocks are centered to the Unistrut and tighten the hardware. Use this channel as a guide and mount the pipe blocks on the remaining three channels in a similar manner.

4. Position two spring nuts in each of the Unistrut channels mounted to the converter. Position these nuts between the pipe blocks and the ends of the Unistrut.

Above the spring nuts, position the flat fitting plates with the locating notches engaged in the openings of the channels.

5. Thread a 5/16" nut, split and flat washer onto each of the threaded rods, leaving 1" of rod remaining. Thread that end of the rod through the flat fitting plates and fully into the spring nuts (do not bottom out).

Using one of the mating channels, ensure that the threaded rods from the channels mounted to the converters are aligned with holes in the mating channels. Center these rods with the channels as well as possible and tighten the hardware.

6. Thread a 5/16" nut, split, flat washer and flat fitting plate on the remaining ends of the threaded rods. This hardware is to secure the mating Unistrut channels from the opposite side of the pole to the threaded rod. Adjust accordingly.
7. Position the converter assembly with the pipe blocks against the pole (refer to Figure C-4), slide the mating Unistrut channels onto the threaded rods from the opposite side (pipe blocks against pole and channels against flat fitting plates). Adjust and fasten with the 5/16" hardware (4 each flat, split washers and nuts).



Figure C-4. Rear View of Converter Installed on Round Pole

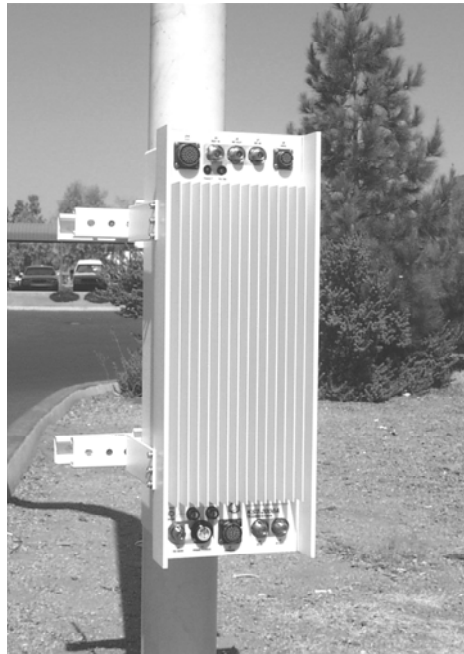

**Figure C-5. Front View of Converter Installed
on Round Pole**

C.2.2.3 Converter Square Pole Mounting Instructions

For square pole mount, please follow the instructions in Section C.2.2.2, but do not use the pipe blocks.

C.3 SSPA Installation

C.3.1 Feed Mount Offset Antenna

The information in this section applies to installation on typical offset antenna of sizes 1.8, 2.4, or 3.8M; with interfaces of 3.74" or 5.25". Refer to Figure C-1 for an illustration.

C.3.1.1 Optional Feed Mount Offset Antenna Installation Kit for SSPA

Refer to Section C.2.1.1.

C.3.1.2 SSPA Feed Mount Offset Antenna Installation Instructions

1. Remove the protective cover from the antenna (OMT) and SSPA (if installed).



After removing the protective cover(s), ensure that no foreign material or moisture enters the antenna waveguide or SSPA.

2. Install the appropriate gasket on the SSPA isolator.
 - a) If only one of the mounting surfaces has a groove, use the thin gasket
 - b) If both mounting surfaces have grooves, then use the thick gasket.
3. Position the SSPA (rounded fins down) on the antenna OMT and fasten using the #6 hardware from KT/2820 (8 each socket head screws, flat, split washers and nuts).
4. Attach the interface bracket to the feed support as follows:
 - a) For PRODELIN 1.8, 2.4, and 3.8 M offset antenna:

Note: An existing 3.74" or 5.25" interface assembly may be used.

Remove the 5/16" nut and washers from the rear bolt of the existing interface assembly on the feed support. Slide the appropriate interface bracket onto the bolt from below the feed support and replace the washers and nut (an example of the 5.25" interface installation is shown in **Do not tighten, leave the bracket loose to accommodate insertion of the "U" bracket in Step 6.**

b) For PRODELIN offset antennas with long feed supports:

Attach the appropriate interface bracket from below the feed support using the existing hole near the end of the feed support. Fasten, using the 1/4" hardware (1" bolt, flat, split washer and nut).

c) For Channel Master antenna:

Attach the interface bracket from below the feed support with the 5/16" hardware and nut plate.

5. Apply the scale overlay to the outward-facing side of the SSPA "U" bracket. See

Note: Either side of the U bracket may face out, depending on the requirements of a particular installation.

6. Slide the SSPA "U" bracket horizontally between the tabs of the interface bracket. Lift and guide the "U" bracket up onto the SSPA while tightening the hardware under the interface bracket. Refer to Figure C-6. Installing the SSPA



Figure C-6. Installing the SSPA

7. Slide two 1/4-20 nuts a short distance down each horizontal side "UNI" channel from the rear of the SSPA. Refer to
8. Figure C-7. Center and square the "U" bracket to the SSPA and fasten using 1/4-20 x 5/8" bolts, 1/4" split washers and 1/4" flat washers. Thread the 10-32 spade screw on the interface bracket and tighten to complete mounting.

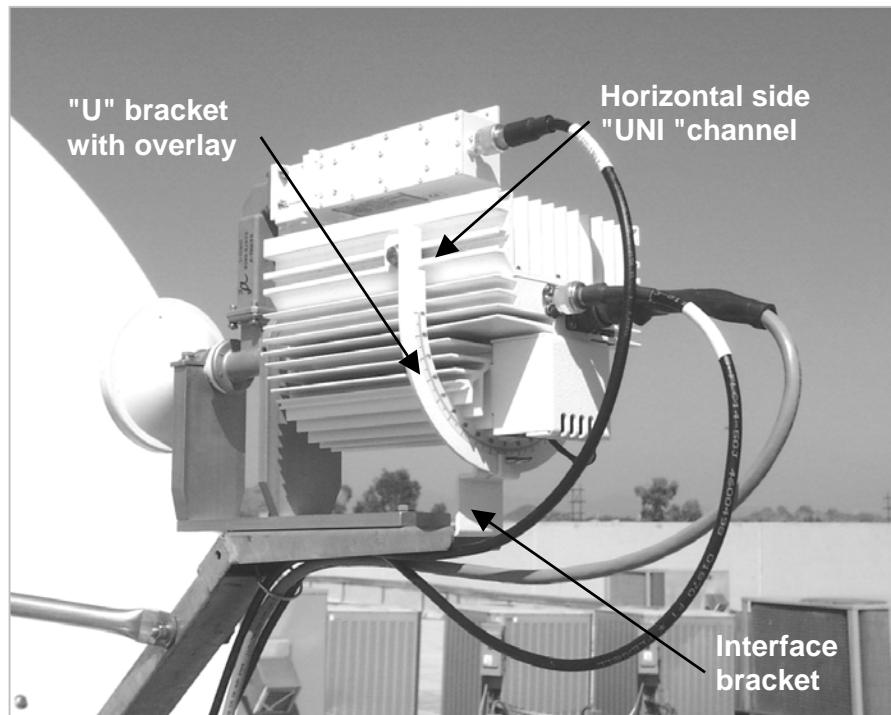

Figure C-7. SSPA Installed





C.4 LNA Installation

C.4.1 Feed Mount Offset Antenna

C.4.1.1 Optional Feed Mount Offset Antenna Installation Kit for LNA

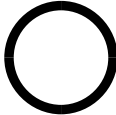
KT/2820 is included in the following mounting kits:

- KT/7805-1
- KT/7945-1
- KT/7595-1

| Kit KT/2820 | | | |
|-------------|--|---|--|
| Qty. | Description | | Qty. |
| 4 | O-ring.  <i>Comtech EFData Part # 32P1037.</i> | 8 | 6-32 x 7/8" socket head cap screw.  <i>Comtech EFData Part # HW/6-32x7/8 SHCS.</i> |
| 16 | #6 flat washer.  <i>Comtech EFData Part # HW/6-FLT.</i> | 8 | #6 split washer.  <i>Comtech EFData Part # HW/6-SPLIT.</i> |
| | | 8 | #6 Hex nut  <i>Comtech EFData Part # HW/6-32HEXNUT</i> |

C.4.1.2 LNA Feed Mount Offset Antenna Installation Instructions

To install a single LNA to an antenna:

1. Remove the protective cover from the antenna OMT and LNA.



After removing the protective cover(s), ensure that no foreign material or moisture enters the antenna waveguide or LNA.

2. Install the appropriate gasket on the antenna end of the LNA.
 - a) If only one of the mounting surfaces has a groove, use the thin gasket.
 - b) If both mounting surfaces have grooves, use the thick gasket.
3. Position the LNA (with gasket) in place on the antenna OMT and fasten using the #6 hardware from KT/2820 (8 each socket head screws, flat, split washers and nuts).

C.5 Cable Installation

Care should be exercised in cable installation. Install the cables using the most direct route and secure with clamps and ties. Avoid all sharp bends.

Cable connectors used in outdoor applications must be sealed to avoid leakage, particularly N-type connectors. Moisture can seep into junctions at the plug end of the connector, between the fixed and movable parts, and where the cable connects to the connector. Signal attenuation and possible loss of signal can occur in the presence of moisture. All cable junctions must be sealed with a self-amalgamating tape, such as 3M, Type 23 Scotch Self-Amalgamating tape, or equivalent, including military style (MS) connectors.

Appendix D. REDUNDANT EQUIPMENT MOUNTING

This section describes the optional installation hardware and procedures for the following applications:

| Section | Installation Description |
|---------|--|
| D.1 | Tools required |
| D.2 | 1:1 Converter installation |
| D.2.1 | Spar arm mount |
| D.2.2 | Pole mount (round or square) |
| | Note: The converter units can be installed anywhere on or near the antenna. |
| D.3 | 1:1 SSPA installation |
| D.3.1 | For offset feed mount antenna |
| D.4 | 1:1 LNA installation |
| D.4.1 | For offset feed mount antenna |
| D.5 | Cable installation |

Installation procedures and hardware kits have been verified on the following antennas:

- PRODELIN 1.8, 2.4, and 3.8M
- Channel Master offset antenna

Figure D-1 is an example of a redundant system that has been installed on the antenna's feedhorn assembly.



Figure D-1. 1:1 System Installed on Spar Arm







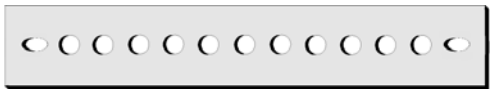

D.1 Tools Required

| Qty. | Description |
|------|---|
| 1 | 3/8" drive ratchet. |
| 1 | Adjustable wrench. |
| 1 | 7/16" x 3/8" drive socket, or 7/16" drive wrench. (Metric equivalent: 12mm, 6 pt.) |
| 1 | 1/2" x 3/8" drive socket, or 1/2" box wrench. (Metric equivalent: 13mm, 6 pt.) |
| 1 | 5/16" box wrench, or nut driver |
| 1 | 7/64" Allen wrench |

D.2 1:1 Converters Installation

D.2.1 Spar Arm Mount

D.2.1.1 Optional Spar Arm Installation Kit for 1:1 Converters, SSPA, and LNA

| Kit PL/7725 includes: | | | |
|-----------------------|---|------|---|
| Qty. | Description | Qty. | Description |
| 2 | Spar support bracket.  <i>Comtech EFData Part # FP/3175. Used for spar mount only.</i> | 2 | 20" Unistrut  <i>Comtech EFData Part # FP/7582-1</i> |
| 12 | 1/4-20 x 5/8" bolt.  <i>Comtech EFData Part # 03P1131 Used to Attach Unistruts to converters.</i> | 4 | 5/16" flat washer  <i>Comtech EFData Part # HW/5/16-FLT</i> |
| 16 | 1/4" flat washer.  <i>Comtech EFData Part # HW/1/4-FLT. Used to Attach Unistruts to converters.</i> | 4 | 5/16" split washer  <i>Comtech EFData Part # HW/5/16-SPLIT</i> |
| 16 | 1/4" split washer.  <i>Comtech EFData Part # HW/1/4-SPLIT. Used to Attach Unistruts to converters</i> | 4 | 5/16"-18 spring nut  <i>Comtech EFData Part # HW/5/16-18spnut</i> |
| 4 | 5/16-18 x 1.25" bolt.  <i>Comtech EFData Part # HW/5/16-18x1.25.</i> | | |

D.2.1.2 1:1 Converters Spar Arm Mounting Instructions

PRODELIN 1.8, 2.4, and 3.8 M: Channel Master 2.4 and 3.8 M.

1. Position the two 20” Unistrut channels on the backside of the RJU-2000 switch box, aligning and centering the two center slots of the channel with the mounting holes of the switch box. Fasten with the 1/4” hardware (4 each bolts, split and flat washers).
2. Position the converters with fins down and mounting brackets facing upward, leaving a gap between roughly the width of the RJU-2000 switch box (refer to Figure D-3). Position and orient the channels, with switch box attached, onto the converter brackets with the switch box between the converters. Ensure that all items are oriented correctly and fasten with the 1/4” hardware (twelve each bolts, split and flat washers).

Note: It may be necessary to loosen the hardware on the switch box in order to align the mounting holes between the Unistrut channels and the converter brackets.

3. Using a Spar support bracket as a guide, position two spring nuts in each of the Unistrut channels. The threaded holes in the spring nuts must be aligned with the holes in the Spar support brackets and should be centered in the Unistrut channels.
4. Position the assembly on the Spar arm of the antenna (refer to Figure D-2) and fasten the Spar support brackets to the spring nuts in the Unistrut with the 5/16” hardware (4 each bolt, split and flat washer). Ensure that the assembly is mounted in such a manner as to provide enough room for cabling and to avoid interference to surrounding objects.

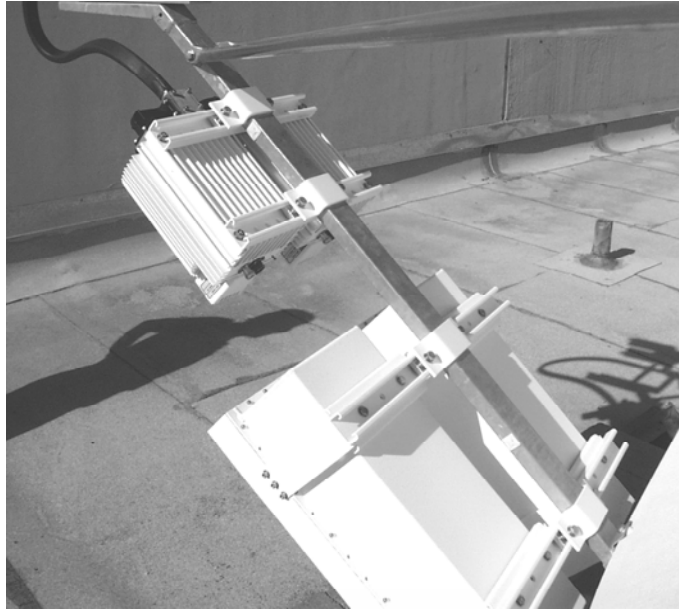
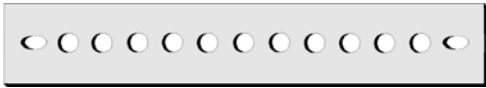







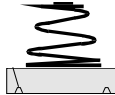



Figure D-2. Converters and SSPAs on Spar Arm

D.2.2 Pole Mount

D.2.2.1 Optional Pole Mount Installation Kit for 1:1 Converters

| Kit KT/8095, which includes: | | | | |
|------------------------------|---|--|------|---|
| Qty. | Description | | Qty. | Description |
| 4 | Unistrut — 20" long.  <i>Comtech EFData Part # FP/7582-1. Used for round and square pole mount only.</i> | | 8 | 5/16-18 x 1 1/4" bolt.  <i>Comtech EFData Part # HW/5/16-18X1.25BLT.</i> |
| 16 | 1/4-20 x 5/8" bolt.  <i>Comtech EFData Part #03P1131. Used to attach Unistruts to converters.</i> | | 28 | 5/16" split washer.  <i>Comtech EFData Part # HW/5/16-SPLIT.</i> |
| 16 | 1/4" flat washer.  <i>Comtech EFData Part # HW/1/4-FLT. Used to attach Unistruts to converters.</i> | | 20 | 5/16" flat washer.  <i>Comtech EFData Part # HW/5/16-FLT.</i> |
| 16 | 1/4" split washer.  <i>Comtech EFData Part # HW/1/4-SPLIT. Used to attach Unistruts to converters.</i> | | 12 | 5/16-18 hex nut.  <i>Comtech EFData Part # HW/5/16-18HEXNT.</i> |
| 8 | Pipe block.  <i>Comtech EFData Part # HW/BLK-PIPE2-8. Used for round pole mount only.</i> | | 12 | 5/16-18 spring nut.  <i>Comtech EFData Part # HW/5/16-18SPNUT.</i> (continued on next page) |

| (continued) Kit KT/8095, which includes: | | | |
|--|---|--|--|
| Qty. | Description | | Qty. |
| 4 | Threaded rod, 5/16-18 x 14".  <i>Comtech EFData Part # HW/RD5/16-18X14. Used for round and square pole mount only.</i> | | 8 |
| | | | Flat fitting plate, 5/16".  <i>Comtech EFData Part # HW/FIT-PLT-5/16.</i> |

D.2.2.2 1:1 Converters Round Pole Mounting Instructions

1. Position the (2), 20" Unistrut channels on the backside of the RJU-2000 switch box, aligning and centering the two center slots of the channel with the mounting holes of the switch box. Fasten with the provided 1/4" hardware (4 each bolts, split and flat washers).
2. Position the converters with fins down and mounting brackets facing upwards leaving a gap between roughly the width of the RJU-2000 switch box (refer to Figure D-3). Position and orient the channels, with the switch box attached, onto the converters brackets with the switch box between the converters. Ensure all items are oriented correctly and fasten with the provided 1/4" hardware (12 each bolts, split and flat washers).

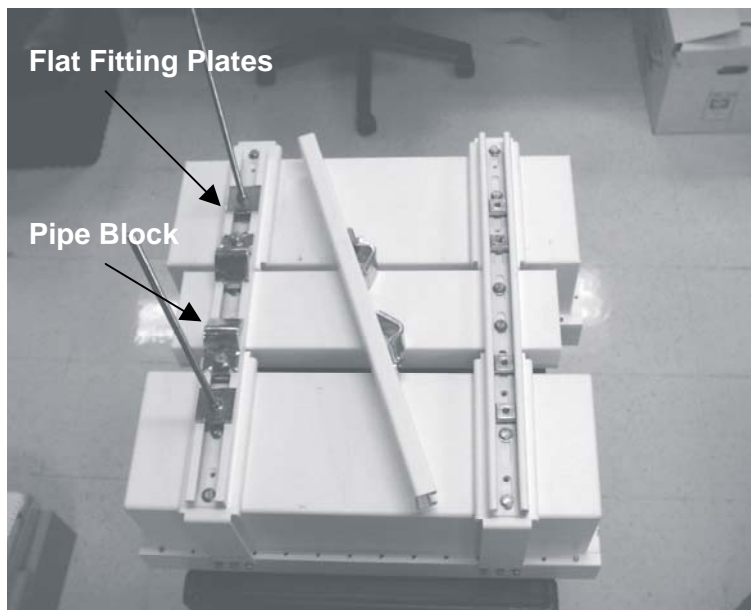

Figure D-3. KST-2000A 1:1 Converters With Mounting Brackets

Note: It may be necessary to loosen the hardware holding the switch box in order to align the mounting holes between the Unistrut channels and the converter brackets.

3. Take one of the two remaining Unistrut channels, position two spring nuts into the channel. Fasten two pipe blocks loosely, with mounting holes facing the ends of the channel, to the spring nuts with the hardware provided (2 each 5/16" bolts, split and flat washers).
4. Place the channel with pipe blocks against the mounting pole, slide the pipe blocks until they contact the mounting pole. ensure that the pipe blocks are centered to the Unistrut and tighten the hardware. Use this channel as a guide for mounting the pipe blocks on the remaining three channels.
5. Position two spring nuts on each Unistrut channel attached to the converters. Position these nuts between the pipe blocks and the ends of the Unistrut. Above the spring nuts position the flat fitting plates with the locating notches engaged in the openings of the channel. Thread a 5/16" nut, split and flat washer onto the threaded rods, leaving 1" of rod remaining. Thread that end of the threaded rods through the flat fitting plates and fully into the spring nuts (do not bottom out). Using one of the mating channels, ensure that the threaded rods from the channels mounted to the converters are aligned with the slots in the mating channel. Center these rods with the channel as best as possible and tighten the hardware.
6. Thread a 5/16" nut, split, flat washer and flat fitting plate on the remaining ends of the threaded rods. This hardware is to secure the mating Unistrut channels from the opposite side of the pole to the threaded rod, adjust accordingly.
7. Position the converters assembly with the pipe blocks against the pole, (refer to Figure D-4), slide the mating Unistrut channels onto the threaded rods from the opposite side (pipe blocks against pole and channels against flat fitting plates). Fasten with the provided 5/16" hardware (4 each flat, split washers, and nuts).

D.2.2.3 1:1 Converters Square Pole Mounting Instructions

For square pole mount, please follow the instructions on Section D.2.2.2, but do not use the pipe blocks.



Figure D-4. Rear View of Converters Installed on Pole

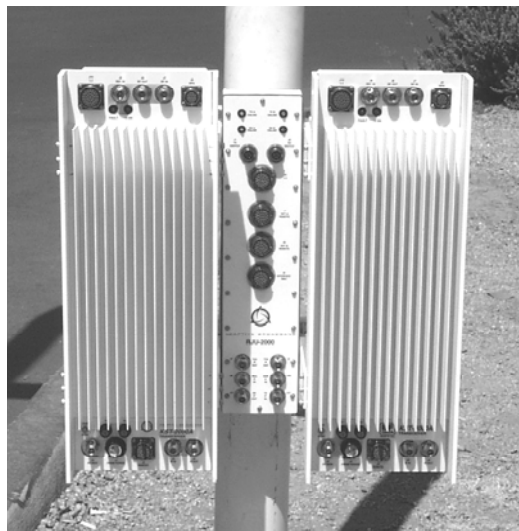

Figure D-5. Front View of Converters Installed on Pole

D.3 1:1 SSPA Installation

D.3.1 Feed Mount Offset Antenna

D.3.1.1 1:1 SSPA Installation Instructions

PRODELIN 1.8, 2.4, and 3.8 M; Channel master 2.4 and 3.8 M

1. Using a Spar support bracket as a guide, position two spring nuts in each of the Unistrut channels of the SSPA assembly. The threaded holes in the spring nuts must be aligned with the holes in the Spar support brackets and should be centered in the Unistrut channels.
2. Position the SSPA redundant assembly on the Spar arm of the antenna (switch facing the feed support). Fasten the assembly to the Spar arm with the provided Spar support brackets and 5/16" hardware (4 each bolt, split and flat washer).

Note: When positioning the SSPA assembly, make allowances for flexible waveguide length from the SSPA assembly to the antenna OMT.

D.4 1:1 LNA Installation

D.4.1 Feed Mount Offset Antenna

D.4.1.1 1:1 LNA Installation Instructions

1. Remove the protective cover(s) from the antenna OMT and LNA assembly filter (if installed).

Note: After removing the covers, ensure that no foreign material or moisture enters the antenna OMT of the LNA filter.

2. Install the appropriate gasket on the antenna OMT.
 - a) If only one of the mounting surfaces has a groove, use the thin gasket.
 - b) If both mounting surfaces have grooves, use the thick gasket.
3. Position the LNA assembly in place on the antenna OMT (with gasket), and fasten with the provided #6 hardware (4 each screws, splits and nuts, 8 each flats).

D.5 Cable Installation

Care should be exercised in cable installation. Install the cables using the most direct route and secure with clamps and ties. Avoid all sharp bends.

Cable connectors used in outdoor applications must be sealed to avoid leakage, particularly N-type connectors. Moisture can seep into junctions at the plug end of the connector, between the fixed and movable parts, and where the cable connects to the connector. Signal attenuation and possible loss of signal can occur in the presence of moisture. All cable junctions must be sealed with a self-amalgamating tape, such as 3M, Type 23 Scotch Self-Amalgamating tape, or equivalent, including military style (MS) connectors.

Appendix E. FSK REMOTE CONTROL COMMANDS

This appendix describes the protocol and message command set for FSK Remote Control Commands used on the KST-2000A, Single-Thread Configuration.

Firmware No. FW/9364-1 and FW/10303-1

E.1 Introduction

Modifications have been made to the KST-2000A (herein after, referred to as the terminal) firmware and hardware to permit monitor and control from the front panel of several Comtech EF Data Satellite Modems. Currently the supported modems include but are not limited to the CDM-550T, CDM-570, and CDM-600 (herein after, referred to as the modem). The control is transmitted via an FSK signal superimposed on the RX connection of the modem.

The modem transmits monitor and control commands via the FSK and the terminal responds. The terminal parameters can be viewed and configured from menus on the modem front panel.

Just as the modem can be controlled via a EIA-232 or EIA-485 bus from an external PC, so can the terminal. The commands from the computer are transmitted to the modem. The address is decoded, if the address indicates a message is for the terminal, the modem transmits the message onto the FSK. The FSK response from the terminal is received and retransmitted via the serial link back to the computer.

The address of the terminal is dictated by the address of the modem. The user selects "Enable ODU," from the front panel of the modem. This initiates several commands to force the terminal address to (modem +1), and interrogate its factory settings. The FSK link format (8N1) and baud rate (9600) are fixed. The standard I/O (eg via EIA-232/EIA-485 direct) of the terminal is unchanged.



Redundant system control is not currently supported.

E.2 Basic Protocol

All data is transmitted as asynchronous serial characters, suitable for transmission and reception by a UART. In this case, the asynchronous character format is fixed at 9600 baud.

All data is transmitted in framed packets. The controller is assumed to be a PC or ASCII dumb terminal, which is in charge of the process of monitor and control. The controller is the only device which is permitted to initiate, at will, the transmission of data. Targets are only permitted to transmit when they have been specifically instructed to do so by the controller.

All bytes within a packet are printable ASCII characters, less than ASCII code 127. In this context, the Carriage Return and Line Feed characters are considered printable.

All messages from controller to target require a response. This will be either to return data which has been requested by the controller, or to acknowledge reception of an instruction to change the configuration of the target.

E.2.1 Packet Structure

Controller-to-target:

Example: <0135/TFQ=70.2345{CR}

Target-to-controller:

Example: >0654/RSW=32{CR}{LF}

Each of the components of the packet is now explained.

E.2.2 Start Of Packet

Controller to Target: This is the character '<' (ASCII code 60)

Target to Controller: This is the character '>' (ASCII code 62)

Because this is used to provide a reliable indication of the start of packet, these two characters may not appear anywhere else within the body of the message.

E.2.3 Address

The terminal address is fixed as: Modem Address +1



The controller sends a packet with the address of a target - the destination of the packet. When the target responds, the address used is the same address, to indicate to the controller the source of the packet. The controller does not have its own address.

E.2.4 Instruction Code

This is a three-character alphabetic sequence which identifies the subject of the message. Wherever possible, the instruction codes have been chosen to have some significance.

For example: UFQ for uplink frequency, DAT for downlink attenuation. This aids in the readability of the message, should it be displayed in its raw ASCII form. Only upper case alphabetic characters may be used (A-Z, ASCII codes 65 - 90).

E.2.5 Instruction Code Qualifier

This is a single character which further qualifies the preceding instruction code.

Code Qualifiers obey the following rules:

1. From Controller to Target, the only permitted values are:
 - = (ASCII code 61)
 - ? (ASCII code 63)

They have these meanings:

The '=' code (controller to target) is used as the assignment operator, and is used to indicate that the parameter defined by the preceding instruction code should be set to the value of the argument(s) which follow it.

For example, in a message from controller to target, UFQ=13750.0 would mean 'set the transmit frequency to 13750 MHz'

The '?' code (controller to target) is used as the query operator, and is used to indicate that the target should return the current value of the parameter defined by the preceding instruction code.

For example, in a message from controller to target, UFQ? would mean 'return the current value of the uplink frequency'

2. From Target to Controller, the only permitted values are:
 - = (ASCII code 61)
 - ? (ASCII code 63)
 - ! (ASCII code 33)
 - * (ASCII code 42)

They have these meanings:

The '=' code (target to controller) is used in two ways:

1. If the controller has sent a query code to a target (for example UFQ?, meaning 'what's the Uplink frequency?'), the target would respond with UFQ=xxxxx.x, where xxxxx.x represents the frequency in question.
2. If the controller sends an instruction to set a parameter to a particular value, then, providing the value sent in the argument is valid, the target will acknowledge the message by replying with UFQ= (with no message arguments).

The '?' code (target to controller) is only used as follows:

If the controller sends an instruction to set a parameter to a particular value, then, if the value sent in the argument is not valid, the target will acknowledge the message by replying (for example) with UFQ? (with no message arguments). This indicates that there was an error in the message sent by the controller.

The '*' code (target to controller) is only used as follows:

If the controller sends an instruction to set a parameter to a particular value, then, if the value sent in the argument is valid, BUT the modem will not permit that particular parameter to be changed at that time, the target will acknowledge the message by replying (for example) with UFQ* (with no message arguments).

The '!' code (target to controller) is only used as follows:

If the controller sends an instruction code which the target does not recognize, the target will acknowledge the message by echoing the invalid instruction, followed by the ! character with. Example: XYZ!

E.2.6 Message Arguments

Arguments are not required for all messages. Arguments are ASCII codes for the characters 0 to 9 (ASCII 48 to 57), period (ASCII 46) and comma (ASCII 44).

E.2.7 End Of Packet

Controller to Target: This is the 'Carriage Return' character (ASCII code 13)

Target to Controller: This is the two-character sequence 'Carriage Return', 'Line Feed'. (ASCII code 13, and code 10.)

Both indicate the valid termination of a packet.

E.3 Commands and Query

The following tables provide the FSK Remote Control Commands.

| A | F | L | U |
|-----------|-----------|-----------|-----------|
| AGC, E-17 | FRW, E-15 | LCS, E-8 | UAT, E-7 |
| AMP, E-9 | | LFL, E-8 | UIF, E-12 |
| ANM, E-12 | | LOK, E-18 | UFQ, E-7 |
| ASF, E-23 | | LSF, E-23 | ULR, E-24 |
| | | R | UMU, E-10 |
| C | H | | USF, E-21 |
| CAL, E-8 | HSF, E-21 | RCS, E14 | |
| CAS, E-17 | | REF, E-8 | |
| CDS, E-18 | | RET, E-10 | |
| CES, E-17 | | RSF, E-21 | |
| CFS, E-16 | | RUS, E-14 | |
| CHS, E-18 | | | |
| CID, E-15 | K | S | |
| CLS, E-9 | | | |
| CRS, E-17 | KFE, E-9 | SFS, E-16 | |
| CSA, E-23 | | SND, E-12 | |
| CSF, E-23 | | SNH, E-11 | |
| CUS, E-18 | | SNM, E-16 | |
| | | SNU, E-11 | |
| D | | SPA, E-8 | |
| DAT, E-7 | | SRB, E-24 | |
| DIF, E-13 | | | |
| DFQ, E-7 | | | |
| DLR, E-24 | | | |
| DSF, E-20 | | | |

| Parameter Type | Command (Instruction Code and qualifier) | Arguments for Command or Response to Query | Description of arguments (note that all arguments are ASCII numeric codes, that is, ASCII codes between 48 and 57) | Response to Command (target to controller) | Query (Instruction Code and qualifier) |
|----------------------------|--|--|--|---|--|
| Up Converter Frequency | UFQ= | 7 bytes | <p>Command or Query. <add/UFQ=nnnnn.n'cr' >add/UFQ='cr''lf'</p> <p><add/UFQ?'cr' >add/UFQ=nnnnn.n'cr''lf'</p> <p>Where: nnnnn.n = 13750.0 to 14500.0 MHz, in 1 MHz steps</p> | <p>UFQ= (message ok) UFQ? (received ok, but invalid arguments found) UFQ* (message ok, but not permitted in current mode)</p> | UFQ? |
| Down Converter Frequency | DFQ= | 7 bytes | <p>Command or Query. <add/DFQ=nnnnn.n'cr' >add/DFQ='cr''lf'</p> <p><add/DFQ?'cr' >add/DFQ=nnnnn.n'cr''lf'</p> <p>Where: nnnnn.n = 10950.0 to 12750.0 MHz, in 1 MHz steps</p> | <p>DFQ= (message ok) DFQ? (received ok, but invalid arguments found) DFQ* (message ok, but not permitted in current mode)</p> | DFQ? |
| Up Converter Attenuation | UAT= | 4 bytes | <p>Command or Query. <add/UAT=nn.n'cr' >add/UAT='cr''lf'</p> <p><add/UAT?'cr' >add/UAT=nn.n'cr''lf'</p> <p>Where: nn.n = 00.0 to 20.0 dB, in 1.0 dB steps</p> | <p>UAT= (message ok) UAT? (received ok, but invalid argument found) UAT* (message ok, but not permitted in current mode)</p> | UAT? |
| Down Converter Attenuation | DAT= | 4 bytes | <p>Command or Query. <add/DAT=nn.n'cr' >add/DAT='cr''lf'</p> <p><add/DAT?'cr' >add/DAT=nn.n'cr''lf'</p> <p>Where: nn.n = 00.0 to 10.0 dB, in 1.0 dB steps</p> | <p>DAT= (message ok) DAT? (received ok, but invalid arguments found) DAT* (message ok, but not permitted in current mode)</p> | DAT? |

| Parameter Type | Command (Instruction Code and qualifier) | Arguments for Command or Response to Query | Description of arguments (note that all arguments are ASCII numeric codes, that is, ASCII codes between 48 and 57) | Response to Command (target to controller) | Query (Instruction Code and qualifier) |
|----------------------------|--|--|--|---|--|
| Reference Frequency Adjust | REF= | 3 bytes | <p>Command or Query. <add/REF=nnn'cr' >add/REF='cr''lf'</p> <p><add/REF?'cr' >add/REF=nnn'cr''lf'</p> <p>Where: nnn = 000 to 255</p> | <p>REF= (message ok) REF? (received ok, but invalid arguments found) REF* (message ok, but not permitted in current mode)</p> | REF? |
| Set Physical Address | SPA= | 3 bytes | <p>Command or Query. <add/SPA=xxx'cr' >add/SPA='cr''lf'</p> <p><add/SPA?'cr' >add/SPA=xxx'cr''lf'</p> <p>Where: xxx = new address</p> | <p>SPA= (message ok) SPA? (received ok, but invalid argument found) SPA* (message ok, but not permitted in current mode)</p> | SPA? |
| LNA Calibrated | CAL= | None | <p>Command only. <add/CAL='cr' >add/CAL='cr''lf'</p> <p>Calibration to allow system to determine nominal LNA power consumption, performed at initial installation only.</p> <p>Note: Not applicable for a TX only system</p> | <p>CAL= (message ok) CAL? (received ok, but invalid argument found) CAL* (message ok, but not permitted in current mode)</p> | n.a. |
| LNA Power Enable | LCS= | 1 byte | <p>Command or Query. <add/LCS=x'cr' >add/LCS='cr''lf'</p> <p><add/LCS?'cr' >add/LCS=x'cr''lf'</p> <p>Where: x = 0 (Off) 1 (On)</p> | <p>LCS= (message ok) LCS? (received ok, but invalid argument found) LCS* (message ok, but not permitted in current mode)</p> | LCS? |
| LNA Fault Enable | LFL= | 1 byte | <p>Command or Query. <add/LFL=x'cr' >add/LFL='cr''lf'</p> | <p>LFL= (message ok) LFL? (received ok, but invalid argument found)</p> | LFL? |

| Parameter Type | Command (Instruction Code and qualifier) | Arguments for Command or Response to Query | Description of arguments (note that all arguments are ASCII numeric codes, that is, ASCII codes between 48 and 57) | Response to Command (target to controller) | Query (Instruction Code and qualifier) |
|----------------------|--|--|--|---|--|
| | | | <p><add/LFL?'cr' >add/LFL=x'cr''lf'</p> <p>Where: x = 0 (Fault reporting disabled) 1 (Fault reporting enabled)</p> | LFL* (message ok, but not permitted in current mode) | |
| Concise LNA Settings | n.a. | 2 bytes | <p>Query only. <add/CLS?'cr' >add/CLS=nx'cr''lf'</p> <p>Where: n = Power Enable; 0 (Off), 1(On) x = Fault Enable; 0 (Disabled), 1 (Enabled)</p> | <p>CLS= (message ok) CLS? (received ok, but invalid argument found) CLS* (message ok, but not permitted in current mode)</p> | CLS? |
| HPA Power Enable | AMP= | 1 byte | <p>Command or Query. <add/AMP=x'cr' >add/AMP='cr''lf'</p> <p><add/AMP?'cr' >add/AMP=x'cr''lf'</p> <p>Where: x=0(Off) or 1(On) Default is 1 (On)</p> <p>Note: For EF Data SSPA only, which turns ON/OFF DC voltage supplied to HPA.</p> | <p>AMP= (message ok) AMP? (received ok, but invalid arguments found) AMP* (message ok, but not permitted in current mode)</p> | AMP? |
| HPA Fault Enable | KFE= | 1 byte | <p>Command or Query. <add/KFE=x'cr' >add/KFE='cr''lf'</p> <p><add/KFE?'cr' >add/KFE=x'cr''lf'</p> <p>Where: x=0 fault reporting disabled y=1 fault reporting enabled</p> | <p>KFE= (message ok) KFE? (received ok, but invalid arguments found) KFE* (message ok, but not permitted in current mode)</p> | KFE? |

| Parameter Type | Command (Instruction Code and qualifier) | Arguments for Command or Response to Query | Description of arguments (note that all arguments are ASCII numeric codes, that is, ASCII codes between 48 and 57) | Response to Command (target to controller) | Query (Instruction Code and qualifier) |
|---------------------|--|--|--|--|--|
| RF Output | UMU= | 1 byte | <p>Command or Query. <add/UMU=x'cr' >add/UMU='cr''lf'</p> <p><add/UMU?'cr' >add/UMU=x'cr''lf'</p> <p>Where: x=0(Off), 1(On), 2(WARM), Default is 0(Off)</p> <p>Note: The Off command keeps the RF output Off under all conditions. The WARM command is a conditional On command telling the RF output to come On after the unit is warmed up and meets the stability requirements, while the On command is an override, instructing the output to be On and ignores the warm start.</p> | <p>UMU=(message ok) UMU? (received ok, but invalid arguments found) UMU* (message ok, but not permitted in current mode)</p> | UMU? |
| Read Equipment Type | RET | 10 bytes | <p>Query only. <add/RET?'cr' >add/RET=sttttttt'cr''lf'</p> <p>Where: ttttttt= KST-2000A s=HPA type, where: 0 = CEFD-SSPA 1 = OEM-SSPA 2 = OEM-TWTA 3 = None</p> | <p>RET= (message ok) RET? (received ok, but invalid argument found) RET* (message ok, but not permitted in current mode)</p> | RET? |

| Parameter Type | Command (Instruction Code and qualifier) | Arguments for Command or Response to Query | Description of arguments (note that all arguments are ASCII numeric codes, that is, ASCII codes between 48 and 57) | Response to Command (target to controller) | Query (Instruction Code and qualifier) |
|-------------------------|--|--|--|---|--|
| Query Serial Number UC | n.a. | 9 bytes | Query only. <add/SNU?'cr' >add/SNU=xxxxxxxx'cr''lf Where: xxxxxxxx = 00000000 to 99999999 | SNU= (message ok) SNU? (received ok, but invalid argument found) SNU* (message ok, but not permitted in current mode) | SNU? |
| Query Serial Number HPA | n.a. | 9 bytes | Query only. <add/SNH?'cr' >add/SNH=xxxxxxxx'cr''lf Where: xxxxxxxx = 00000000 to 99999999 | SNH= (message ok) SNH? (received ok, but invalid argument found) SNH* (message ok, but not permitted in current mode) | SNH? |

| Parameter Type | Command (Instruction Code and qualifier) | Arguments for Command or Response to Query | Description of arguments (note that all arguments are ASCII numeric codes, that is, ASCII codes between 48 and 57) | Response to Command (target to controller) | Query (Instruction Code and qualifier) |
|-----------------------------|--|--|--|--|--|
| Query Serial Number DC | n.a. | 9 bytes | Query only. <add/SND?'cr' >add/SND=xxxxxxxx'cr'lf' Where: xxxxxxxx = 00000000 to 99999999 | SND= (message ok) SND? (received ok, but invalid arguments found) SND* (message ok, but not permitted in current mode) | SND? |
| Up Slice Information String | n.a. | 41 bytes | Query only. <add/UIF?'cr' >add/UIF=ffff,bbbb,iii,aa,llll,gg,s,pp,rr,www,cc,'cr'lf' Where: ffff=Start freq in MHz bbbb= Freq range in MHz (bandwidth) iii=IF freq in MHz aa=max attenuation llll= IFLO gg= Cal GAIN in dB s= 0 for Lowside LO, 1 for Highside LO pp=rated output power in dBm rr=max expected Raw Gain in dB www=Channel bandwidth in MHz cc=Allowed user atten range in dB Ex: UIF=10950,1800,070,25,1180,45,1,10,57,036,25, | UIF= (message ok) UIF? (received ok, but invalid argument found) UIF* (message ok, but not permitted in current mode) | UIF? |

| Parameter Type | Command (Instruction Code and qualifier) | Arguments for Command or Response to Query | Description of arguments (note that all arguments are ASCII numeric codes, that is, ASCII codes between 48 and 57) | Response to Command (target to controller) | Query (Instruction Code and qualifier) |
|-------------------------------|--|--|---|---|--|
| Down Slice Information String | n.a. | 41 bytes | Query only. <add/DIF?' cr' >add/DIF=ffff,bbbb,iii,aa,llll,gg,s,pp,rr,www,cc,' cr'lf' Where: ffff=Start freq in MHz bbbb= Freq range in MHz (bandwidth) iii=IF freq in MHz aa=max attenuation llll=IFLO gg= Cal GAIN in dB s= 0 for Lowside LO, 1 for Highside LO pp=rated output power in dBm rr=max expected Raw Gain in dB www=Channel bandwidth in MHz cc=Allowed user atten range in dB Ex: DIF=10950,1800,070,20,1180,45,1,10,57,036,20, | DIF= (message ok) DIF? (received ok, but invalid argument found) DIF* (message ok, but not permitted in current mode) | DIF? |

| Parameter Type | Command (Instruction Code and qualifier) | Arguments for Command or Response to Query | Description of arguments (note that all arguments are ASCII numeric codes, that is, ASCII codes between 48 and 57) | Response to Command (target to controller) | Query (Instruction Code and qualifier) |
|-----------------------------|--|--|--|---|--|
| System Configuration Status | n.a. | 67 bytes | <p>Query only. <add/RCS?'cr' >add/RCS='cr' UFQ=nnnnn.n'cr' DFQ=nnnnn.n'cr' UMU=x'cr' UAT=nn.n'cr' DAT=nn.n'cr' SEL=n'cr' AGC=n'cr' HPA=xy'cr''lf'</p> <p>Where: x=HPA power enable (as AMP) y=HPA fault enable (as KFE)</p> <p>Note: The converter configuration status command causes a block of data to be returned by the addressed unit. The block of data reflects the correct configuration status.</p> | <p>RCS= (message ok) RCS? (received ok, but invalid arguments found) RCS* (message ok, but not permitted in current mode)</p> | RCS? |
| Retrieve Utility Status | n.a. | 17 bytes | <p>Query only. <add/RUS?'cr' >add/RUS='cr' BDR=9600'cr' REF=nnn'cr''lf'</p> <p>Where: nnn = 000 to 255</p> | <p>RUS= (message ok) RUS? (received ok, but invalid argument found) RUS* (message ok, but not permitted in current mode)</p> | RUS? |

| Parameter Type | Command (Instruction Code and qualifier) | Arguments for Command or Response to Query | Description of arguments (note that all arguments are ASCII numeric codes, that is, ASCII codes between 48 and 57) | Response to Command (target to controller) | Query (Instruction Code and qualifier) |
|------------------------------|--|--|--|---|--|
| Circuit Identification (CID) | CID= | 24 bytes | <p>Command or Query. <add/CID=abcdefghijklmnopqrstuvwx'cr' >add/CID='cr''lf</p> <p><add/CID?'cr' >add/CID=abcdefghijklmnopqrstuvwx'cr''lf</p> <p>Note: The CID shall contain 24 characters. Valid characters include: Space () * + = , . / 0-9 A-Z</p> | <p>CID= (message ok) CID? (received ok, but invalid argument found) CID* (message ok, but not permitted in current mode)</p> | CID? |
| Firmware Numbers | n.a. | 52 bytes | <p>Query only. <add/FRW?'cr' >add/FRW=aaaaaaabbbbbccccccddddddeeeeeeffffffggggggghhh'cr''lf</p> <p>Where: aaaaaaa=M&C FW # with dash and rev (eg. 7084-1G)* bbbbbb=M&C FW # version (eg. 010012 for 01.00.12) cccccc=Up converter FW # with dash and rev* dddddd=Up converter FW # version eeeeeee=Down converter FW #with dash and rev* ffffff=Down converter FW #version ggggggg=HPA FW # with dash and rev* hhhhhh =HPA FW #version</p> <p>Firmware numbers have exceed 999-1X.</p> <ul style="list-style-type: none"> Numbers 0000 to 6999 shall be decoded as 10000 to 16999. Numbers 7000 to 9999 are decoded as is. | <p>FRW= (message ok) FRW? (received ok, but invalid arguments found) FRW* (message ok, but not permitted in current mode)</p> | FRW? |
| Assembly Numbers | n.a. | 28 bytes | <p>Query only. <add/ANM?'cr' >add/ANM=aaaaaaabbbbbccccccddddd'cr''lf</p> | <p>ANM= (message ok) ANM? (received ok, but invalid arguments found) ANM* (message ok, but not permitted in current mode)</p> | ANM? |

| Parameter Type | Command (Instruction Code and qualifier) | Arguments for Command or Response to Query | Description of arguments (note that all arguments are ASCII numeric codes, that is, ASCII codes between 48 and 57) | Response to Command (target to controller) | Query (Instruction Code and qualifier) |
|----------------------|--|--|--|---|--|
| | | | <p>Where: aaaaaa=M&C ASSY # with dash and rev bbbbbb=Up converter ASSY # with dash and rev cccccc=Down Converter ASSY # with dash and rev ddddd=HPA firmware ASSY # with dash and rev</p> <p>Firmware numbers have exceed 999-1X.</p> <ul style="list-style-type: none"> Numbers 0000 to 6999 shall be decoded as 10000 to 16999. <p>Numbers 7000 to 9999 are decoded as is.</p> | | |
| Serial Numbers | n.a. | 36 bytes | <p>Query only. <add/SNM?'cr' >add/SNM=aaaaaaaabbbbbbbcccccccddeeeeee'cr''lf'</p> <p>Where: aaaaaaaa=M&C Serial Number bbbbbb=Up Converter Serial Number cccccc=Down Converter Serial Number ddeeeeee=HPA firmware Serial Number</p> | <p>SNM= (message ok) SNM? (received ok, but invalid arguments found) SNM* (message ok, but not permitted in current mode)</p> | SNM? |
| Summary Fault Status | n.a. | 1 byte | <p>Query only. <add/SFS?'cr' >add/SFS=x'cr''lf'</p> <p>Where: x=0=No Fault, 1=Fault</p> | <p>SFS= (message ok) SFS? (received ok, but invalid arguments found) SFS* (message ok, but not permitted in current mode)</p> | SFS? |
| Concise Fault Status | n.a. | 7 bytes | <p>Query only. <add/CFS?'cr' >add/CFS=ABCDEFG'cr''lf'</p> <p>Where: A=Common Equipment Status, 0=OK, 1=FLT B=Reference Status, 0=OK, 1=FLT C=AGS Status, 0=OK, 1=FLT D=Up Converter Status, 0=OK, 1=FLT E=Down Converter Status, 0=OK, 1=FLT F=HPA Status, 0=OK, 1=FLT G=LNA Status, 0=OK, 1=FLT</p> | <p>CFS= (message ok) CFS? (received ok, but invalid arguments found) CFS* (message ok, but not permitted in current mode)</p> | CFS? |

| Parameter Type | Command (Instruction Code and qualifier) | Arguments for Command or Response to Query | Description of arguments (note that all arguments are ASCII numeric codes, that is, ASCII codes between 48 and 57) | Response to Command (target to controller) | Query (Instruction Code and qualifier) |
|---------------------------------|--|--|---|--|--|
| Concise Common Equipment Status | n.a. | 4 bytes | Query only. <add/CES?'cr' >add/CES=ABCD'cr''lf' Where: A=-7V PS Status, 0=OK, 1=FLT B=+7V PS Status, 0=OK, 1=FLT C=+12V PS Status, 0=OK, 1=FLT D=+17V PS Status, 0=OK, 1=FLT | CES= (message ok) CES? (received ok, but invalid arguments found) CES* (message ok, but not permitted in current mode) | CES? |
| Concise Reference Status | n.a. | 6 bytes | Query only. <add/CRS?'cr' >add/CRS=ABCDEF'cr''lf' Where: A=REF Source, 0=INT, 1=EXT B=Oscillator State, 0=COLD, 1=WARM C=72M Lock Status, 0=OK, 1=FLT D=EXT REF Lock Status, 0=OK, 1=FLT, 2=NA E=EXT REF Phase_N Status, 0=OK, 1=FLT, 2=NA F= EXT REF Range Status, 0=OK, 1=FLT, 2=NA Note: IF REF source is INT, then D, E, F, shall be 2 (NA). | CRS= (message ok) CRS? (received ok, but invalid arguments found) CRS* (message ok, but not permitted in current mode) | CRS? |
| Concise AGC Status | n.a. | 3 bytes | Query only. <add/CAS?'cr' >add/CAS=ABC'cr''lf' Where: A=Loop Convergence, 0=OK, 1=FLT B=Excessive Input Power (EIP), 0=OK, 1=FLT C=Insufficient Input Power (IIP), 0=OK, 1=FLT | CAS= (message ok) CAS? (received ok, but invalid arguments found) CAS* (message ok, but not permitted in current mode) | CAS? |
| Automatic Gain Control | AGC= | 1 byte | Command or Query <add/AGC=x'cr' >add/AGC='cr''lf' <add/AGC?'cr' >add/AGC=x'cr''lf' Where = X = 0 (Unlock) 1 (Lock) | AGC= (message ok) AGC? (received ok, but invalid arguments found) AGC* (message ok, but not permitted in current mode) | AGC? |

| Parameter Type | Command (Instruction Code and qualifier) | Arguments for Command or Response to Query | Description of arguments (note that all arguments are ASCII numeric codes, that is, ASCII codes between 48 and 57) | Response to Command (target to controller) | Query (Instruction Code and qualifier) |
|-------------------------------|--|--|---|--|--|
| Configuration Lock | LOC= | 1 byte | Command or Query <add/LOC=x'cr' >add/LOC='cr''lf' <add/LOC?'cr' >add/LOC=x'cr''lf' Where: X = 0 (Unlock) 1 (Lock) | LOK= (message ok) LOK? (received ok, but invalid arguments found) LOK* (message ok, but not permitted in current mode) | LOC? |
| Concise Up Converter Status | n.a. | 4 bytes | Query only. <add/CUS?'cr' >add/CUS=ABCD'cr''lf' Where: A=Overtemperature Status, 0=OK, 1=FLT B=L-Band Synthesizer Lock Status, 0=OK, 1=FLT C=Ku-Band Synthesizer Lock Status, 0=OK, 1=FLT D=Interprocessor Comm. Status, 0=OK, 1=FLT | CUS= (message ok) CUS? (received ok, but invalid arguments found) CUS* (message ok, but not permitted in current mode) | CUS? |
| Concise Down Converter Status | n.a. | 4 bytes | Query only. <add/CDS?'cr' >add/CDS=ABCD'cr''lf' Where: A=Overtemperature Status, 0=OK, 1=FLT B=L-Band Synthesizer Lock Status, 0=OK, 1=FLT C=Ku-Band Synthesizer Lock Status, 0=OK, 1=FLT D=Interprocessor Comm. Status, 0=OK, 1=FLT | CDS= (message ok) CDS? (received ok, but invalid arguments found) CDS* (message ok, but not permitted in current mode) | CDS? |
| Concise HPA Status | n.a. | 5 bytes | Query only. <add/CHS?'cr' >add/CHS=ABCDE'cr''lf' Where: A=Overtemperature Status, 0=OK, 1=FLT, 2=NA B=9.75V Status, 0=OK, 1=FLT, 2=NA C=-5V Status, 0=OK, 1=FLT, 2=NA D=BIAS Voltage Summary Status, 0=OK, 1=FLT, 2=NA E=Interprocessor Comm. Status, 0=OK, 1=FLT, 2=NA Note: Item D is the logical OR (shown as 1 or 0) of all the bias voltage status information as shown: | CHS= (message ok) CHS? (received ok, but invalid arguments found) CHS* (message ok, but not permitted in current mode) | CHS? |

| Parameter Type | Command (Instruction Code and qualifier) | Arguments for Command or Response to Query | Description of arguments (note that all arguments are ASCII numeric codes, that is, ASCII codes between 48 and 57) | Response to Command (target to controller) | Query (Instruction Code and qualifier) |
|----------------|--|--|---|--|--|
| | | | Where: 2W SSPA – Item D=BV1 8W SSPA – Item D=BV1 BV2 BV3 16W SSPA – Item D=BV1 BV2 BV3 BV4 BV5 25W SSPA – Item D=BV1 BV2 BV3 BV4 BV5 BV6 BV7 BV8 BV9 | | |

| Parameter Type | Command (Instruction Code and qualifier) | Arguments for Command or Response to Query | Description of arguments (note that all arguments are ASCII numeric codes, that is, ASCII codes between 48 and 57) | Response to Command (target to controller) | Query (Instruction Code and qualifier) |
|------------------------------|--|--|--|--|--|
| Up Converter Stored Faults | n.a. | 6 bytes | Query only. <add/USF?X'cr' >add/USF=ABCDEF'cr''lf' or >add/USF=NO_FAULT'cr''lf' Where: A=Overtemperature Status, 0=OK, 1=FLT B=S-Band Synthesizer Lock Status, 0=OK, 1=FLT C=Ku-Band Synthesizer Lock Status, 0=OK, 1=FLT D=Latched S-Band Synthesizer Lock Status, 0=OK, 1=FLT E=Latched Ku-Band Synthesizer Lock Status, 0=OK, 1=FLT F=Interprocessor comm.Status, 0=OK, 1=FLT X=Stored Fault Locations (0 to 9) | USF= (message ok) USF? (received ok, but invalid arguments found) USF* (message ok, but not permitted in current mode) | USF? |
| Down Converter Stored Faults | n.a. | 6 bytes | Query only. <add/DSF?X'cr' >add/DSF=ABCDEF'cr''lf' or >add/DSF=NO_FAULT'cr''lf' Where: A=Overtemperature Status, 0=OK, 1=FLT B=L-Band Synthesizer Lock Status, 0=OK, 1=FLT C=Ku-Band Synthesizer Lock Status, | DSF= (message ok) DSF? (received ok, but invalid arguments found) DSF* (message ok, but not permitted in current mode) | DSF? |

| Parameter Type | Command (Instruction Code and qualifier) | Arguments for Command or Response to Query | Description of arguments (note that all arguments are ASCII numeric codes, that is, ASCII codes between 48 and 57) | Response to Command (target to controller) | Query (Instruction Code and qualifier) |
|----------------|--|--|--|--|--|
| | | | 0=OK, 1=FLT D=Latched L-Band Synthesizer Lock Status, 0=OK, 1=FLT E=Latched Ku-Band Synthesizer Lock Status, 0=OK, 1=FLT F=Interprocessor Comm.Status, 0=OK, 1=FLT X=Stored Fault Locations (0 to 9) | | |

| Parameter Type | Command (Instruction Code and qualifier) | Arguments for Command or Response to Query | Description of arguments (note that all arguments are ASCII numeric codes, that is, ASCII codes between 48 and 57) | Response to Command (target to controller) | Query (Instruction Code and qualifier) |
|----------------------------------|--|--|---|---|--|
| Reference Stored Faults | n.a. | 6 bytes | <p>Query only. <add/RSF?X'cr' >add/RSF=ABCDEF'cr''lf' or >add/RSF=NO_FAULT'cr''lf'</p> <p>Where: A=REF Source, 0=OK, 1=FLT B=Oscillator State, 0=COLD, 1=EXT C=72M Lock Status, 0=OK, 1=FLT D=EXT REF Lock Status, 0=OK, 1=FLT E=EXT REF Phase_N Status, 0=OK, 1=FLT, 2=NA F=EXT REF Range Status, 0=OK, 1=FLT, 2=NA X=Stored Fault Locations (0 to 9)</p> | <p>RSF= (message ok) RSF? (received ok, but invalid arguments found) RSF* (message ok, but not permitted in current mode)</p> | RSF? |
| HPA Stored Faults (2 and 4 Watt) | n.a. | 5 bytes | <p>Query only. <add/HSF?X'cr' >add/HSF=ABCDE'cr''lf' or >add/HSF=NO_FAULT'cr''lf'</p> <p>Where: A=Overtemperature Status, 0=OK, 1=FLT B=9.75V Status, 0=OK, 1=FLT C=-5V Status, 0=OK, 1=FLT D=BV1 Summary Status, 0=OK, 1=FLT E=Interprocessor Comm.Status, 0=OK, 1=FLT X=Stored Fault Locations (0 to 9)</p> | <p>HSF= (message ok) HSF? (received ok, but invalid arguments found) HSF* (message ok, but not permitted in current mode)</p> | HSF? |

| Parameter Type | Command (Instruction Code and qualifier) | Arguments for Command or Response to Query | Description of arguments (note that all arguments are ASCII numeric codes, that is, ASCII codes between 48 and 57) | Response to Command (target to controller) | Query (Instruction Code and qualifier) |
|-----------------------------|--|--|---|---|--|
| HPA Stored Faults (8 Watt) | n.a. | 7 bytes | <p>Query only. <add/HSF?X'cr' >add/HSF=ABCDEFG'cr''lf' or >add/HSF=NO_FAULT'cr''lf'</p> <p>Where: A=Overtemperature Status, 0=OK, 1=FLT B=9.75V Status, 0=OK, 1=FLT C=-5V Status, 0=OK, 1=FLT D=BV1 Summary Status, 0=OK, 1=FLT E=BV2 Summary Status, 0=OK, 1=FLT F=BV3 Summary Status, 0=OK, 1=FLT G=Interprocessor comm. Status, 0=OK, 1=FLT X=Stored Fault Locations (0 to 9)</p> | <p>HSF= (message ok) HSF? (received ok, but invalid arguments found) HSF* (message ok, but not permitted in current mode)</p> | HSF? |
| HPA Stored Faults (25 Watt) | n.a. | 13 bytes | <p>Query only. <add/HSF?X'cr' >add/HSF=ABCDEFGHIJKLM'cr''lf' or >add/HSF=NO_FAULT'cr''lf'</p> <p>Where: A=Overtemperature Status, 0=OK, 1=FLT B=9.75V Status, 0=OK, 1=FLT C=-5V Status, 0=OK, 1=FLT D=BV1 Summary Status, 0=OK, 1=FLT E=BV2 Summary Status, 0=OK, 1=FLT F=BV3 Summary Status, 0=OK, 1=FLT G=BV4 Summary Status, 0=OK, 1=FLT H=BV5 Summary Status, 0=OK, 1=FLT I=BV6 Summary Status, 0=OK, 1=FLT J=BV7 Summary Status, 0=OK, 1=FLT K=BV8 Summary Status, 0=OK, 1=FLT L=BV9 Summary Status, 0=OK, 1=FLT M=Interprocessor Comm. Status, 0=OK, 1=FLT X=Stored Fault Locations (0 to 9)</p> | <p>HSF= (message ok) HSF? (received ok, but invalid arguments found) HSF* (message ok, but not permitted in current mode)</p> | HSF? |

| Parameter Type | Command (Instruction Code and qualifier) | Arguments for Command or Response to Query | Description of arguments (note that all arguments are ASCII numeric codes, that is, ASCII codes between 48 and 57) | Response to Command (target to controller) | Query (Instruction Code and qualifier) |
|--------------------------------|--|--|--|--|--|
| LNA Stored Faults | n.a. | 1 byte | Query only. <add/LSF?X'cr' >add/LSF=A'cr''lf' or >add/LSF=NO_FAULT'cr''lf' Where: A=LNA Status, 0=OK, 1=FLT X= Stored Fault Locations (0 to 9) | LSF= (message ok) LSF? (received ok, but invalid arguments found) LSF* (message ok, but not permitted in current mode) | LSF? |
| AGC Stored Faults | n.a. | 3 bytes | Query only. <add/ASF?X'cr' >add/ASF=ABC'cr''lf' or >add/ASF=NO_FAULT'cr''lf' Where: A=Loop Convergence, 0=OK, 1=FLT B=Excessive Input Power (EIP), 0=OK, 1=FLT C=Insufficient Input Power (IIP), 0=OK, 1=FLT X=Stored Fault Locations (0 to 9) | ASF= (message ok) ASF? (received ok, but invalid arguments found) ASF* (message ok, but not permitted in current mode) | ASF? |
| Common Equipment Stored Faults | n.a. | 4 bytes | Query only. <add/CSF?X'cr' >add/CSF=ABCD'cr''lf' or >add/CSF=NO_FAULT'cr''lf' Where: A=-7V PS Status, 0=OK, 1=FLT B=+7V PS Status, 0=OK, 1=FLT C=+12V PS Status, 0=OK, 1=FLT D=+17V PS Status, 0=OK, 1=FLT X=Stored Fault Locations (0 to 9) | CSF= (message ok) CSF? (received ok, but invalid arguments found) CSF* (message ok, but not permitted in current mode) | CSF? |
| Clear Stored Faults | CSA= | None | Command only. <add/CSA='cr' >add/CSA='cr''lf' | CSA= (message ok) CSA? (received ok, but invalid arguments found) CSA* (message ok, but not permitted in current mode) | n.a. |

| Parameter Type | Command (Instruction Code and qualifier) | Arguments for Command or Response to Query | Description of arguments (note that all arguments are ASCII numeric codes, that is, ASCII codes between 48 and 57) | Response to Command (target to controller) | Query (Instruction Code and qualifier) |
|-------------------------------------|--|--|--|--|--|
| Clear Latched Up Converter Faults | ULR= | None | Command only. <add/ULR='cr' >add/ULR='cr''lf | ULR= (message ok) ULR? (received ok, but invalid arguments found) ULR* (message ok, but not permitted in current mode) | n.a. |
| Clear Latched Down Converter Faults | DLR= | None | Command only. <add/DLR='cr' >add/DLR='cr''lf | DLR= (message ok) DLR? (received ok, but invalid arguments found) DLR* (message ok, but not permitted in current mode) | n.a. |
| Set Receive Band | SRB= | 1 byte | Command/Query. <add/SRB=n'cr' >add/SRB='cr''lf <add/SRB?'cr' >add/SRB=n'cr''lf Where n = A, B, or C the receive band. | SRB= (message ok) SRB? (received ok, but invalid arguments found) SRB* (message ok, but not permitted in current mode) | SRB? |

Glossary

The following is a list of acronyms and abbreviations that may be found in this manual.

| Acronym/ Abbreviation | Definition |
|--------------------------|--|
| Ω | Ohms |
| A | Ampere |
| AC | Alternating Current |
| AGC | Automatic Gain Control |
| ASA | Address Select Unit A |
| ASB | Address Select Unit B |
| ASCII | American Standard Code for Information Interchange |
| C | Celsius |
| CAL | Calibrate |
| CLNA | Calibrated LNA |
| CLR | CLEAR |
| COMP | Compensation |
| CR | Carriage Return |
| D/C | Down Converter |
| Db | Decibels |
| dBc | Decibels referred to carrier |
| dBm | Decibels referred to 1.0 milliwatt |
| DC | Direct Current |
| DCA | Down Converter Attenuation |
| DCF | Down Converter Frequency |
| DCT | Down Converter Temperature |
| DL | Down Link Fault |
| DLA | Down Link Fault — Unit A |
| DLB | Down Link Fault — Unit B |
| DLD | Down Converter Lock Detect Fault |
| DLM | Down Link Mode (Auto or Manual) |
| DLS | Down Link Switch (A or B) |
| DRO | Dielectric Resonator Oscillator |
| DTM | Down Converter Tuning Voltage Fault |
| EIRP | Equivalent Isotropically Radiated Power |

| | |
|--------|---|
| EN | Enable |
| ERR | Error |
| ESC | Escape |
| EXE | Executable |
| FLT | Fault |
| G/T | Gain Over Temperature |
| GHz | Gigahertz (10 ⁹ Hertz) |
| GND | Ground |
| HPA | High Power Amplifier |
| HPT | HPA Temperature |
| HPV | HPA Internal 12 VDC Power |
| Hz | Hertz (cycle per second) |
| IF | Intermediate Frequency |
| IF TUN | Intermediate Frequency Tuning |
| ILD | IF LO Lock Detect Fault |
| INI | Initialize |
| ITM | IF LO Tuning Voltage Fault |
| k | kilo (10 ³) |
| KΩ | kilo-ohms |
| kHz | Kilohertz (10 ³ Hertz) |
| KPA | Ku-Band Power Amplifier |
| LCD | Liquid Crystal Display |
| LED | Light Emitting Diode |
| LFE | LNA Fault Enable |
| LK | Lock |
| LNA | Low Noise Amplifier |
| LNB | Low Noise Block |
| LO | Local Oscillator |
| m | milli (10 ⁻³) |
| M&C | Monitor and Control |
| Ma | Milliamp |
| Max | Maximum |
| MHz | Megahertz (10 ⁶ Hertz) |
| Min | Minimum or Minute |
| ns | Nanosecond (10 ⁻⁹ second) |
| OCVCXO | Oven Controlled Voltage Controlled Crystal Oscillator |
| OMT | Orthogonal Mode Transducer |
| P-P | Peak-to-Peak |
| PC | Printed Circuit |
| PLO | Phase Locked Oscillator |
| PROG | Program |
| PS | Power Supply |
| PSIG | Pressure per Square Inch Gauge |
| RAM | Random Access Memory |
| REF | Reference |
| RF | Radio Frequency |
| RFJ | Reference Frequency Adjust (10 MHz) |
| RFRF | RF Output |
| RFT | Radio Frequency Terminal |
| RH | Relative Humidity |
| RMA | Return Material Authorization |
| RST | Restart Fault |
| RSU | Redundancy Switch Unit |
| RX | Receive (Receiver) |
| SEL | Select |
| SSPA | Solid State Power Amplifier |

| | |
|---------|-----------------------------------|
| TDV | Down Converter Tuning Voltage |
| TIV | IF LO Tuning Voltage |
| TRF | Transmit Reject Filter |
| TUV | Up Converter Tuning Voltage |
| TWT | Traveling Wave Tube |
| TWTA | Traveling Wave Tube Amplifier |
| TX | Transmit (Transmitter) |
| U/C | Up Converter |
| U/C TUN | Up Converter Tuning |
| UCA | UP Converter Attenuation |
| UCF | Up Converter Frequency |
| UCT | Up Converter Temperature |
| UL | Up Link Fault |
| ULA | Up Link Fault — Unit A |
| ULB | Up Link Fault — Unit B |
| ULD | Up Converter Lock Detect Fault |
| ULM | Up Link Mode (Auto or Manual) |
| ULS | Up Link Switch (A or B) |
| UTM | Up Converter Tuning Voltage Fault |
| V | Volts |
| VAC | Volts, Alternating Current |
| VDC | Volts, Direct Current |
| VSAT | Very Small Aperture Terminal |
| VSWR | Voltage Standing Wave Ration |
| W | Watt |
| WRM | Warm |
| XFE | External Fault Enable |
| XVA | External Input Power from Unit A |
| XVB | External Input Power from Unit B |

Index

1

1
1 Connector (J10), 2–12
1 Connector (J10) Pin Assignments, 2–12
1 Interface Connector (J3), 3–11
1 Interface Connector J3 Pinout Description, 3–11
1 Redundant System Block Diagram, 3–7
16 Watt SSPA Connections, 2–14
16 Watt SSPA Equipment Outline, A–4

2

2 and 4 Watt SSPA Connections, 2–13
2 and 4 Watt SSPA Equipment Outline, A–2
25 Watt SSPA Connections, 2–17

8

8 Watt SSPA Connections, 2–13
8 Watt SSPA Equipment Outline, A–3

A

Adaptive Broadband SSPAs, 2–13
AGC, 1–11, 3–3, 3–9, 4–3
Areas of Operation, 1–3
Automatic Gain Control (AGC), 1–2, 3–28

C

Connector J1 Pinout Description, 3–10
Connector J2 Pinout Description, 3–10
Converter Unit, 1–1, 1–10, 1–11, 2–4, 2–5
Converter Unit External Connections, 2–5
Converter Unit Specifications, 1–10, 1–11

D

Description of Options, 2–3
Downlink Setup, 3–4

E

Electrical Connections, 2–4

F

Fan (J4) Pin Assignments, 2–13
Fault Indication, 4–1
Fault Isolation, 4–2
Features, 1–4
Full Ku-Band Transmit and Receive Coverage, 1–4

H

HPA Connector (J8) Pin Assignments (>25W SSPA Applications), 2–10
HPA Connector (J8) Pin Assignments (TWTA Connection), 2–11

I

I/O View of KST-2000A/B Converter Unit, 2–4
IF IN Connector (J3), 2–8
IF OUT Connector (J4), 2–8
IF to S-Band Converter Module Block Diagram, 3–25
Initial Setup (Single Thread System), 3–1
Initial Setup Redundant System, 3–5
Interface M&C Connector J6 Pinout Description, 3–14

K

KST-2000A Converter Equipment Outline, A-7
KST-2000A/B Converter Unit and 8 Watt SSPA, 1-1
KST-2000A/B Fault Tree, 4-3
Ku to L-Band Down Converter Description (KST-2000A),
3-26
Ku to L-Band Down Converter Module Block Diagram, 3-
26
Ku-Band LNA Equipment Outline, A-6

L

L-Band to IF Down Converter Block Diagram, 3-27
L-Band to IF Down Converter Description (KST-
2000A/B), 3-27
LNA Characteristics, 1-12
LNA Connections, 2-20
LNB Characteristics, 1-12
LNB Connections, 2-20

M

Meets Industry Standards, 1-5
Monitor and Control (M&C), 3-23

R

Redundant HPA Assembly, 3-18
Redundant Junction Unit Description, 3-8
Redundant KST-2000A System Block Diagram, 1-9
Redundant KST-2000A/B System Showing Units A and B
Designation, 3-17
Redundant LNA/B Assembly, 3-19
Redundant System, 2-2, 3-5, 3-7
Redundant System Components, 2-2

REF IN Connector (J9), 2-11
Reference Oscillator, 3-22
Remote Connector (J2), 2-6
Remote M&C Connector (J2) Pin Assignments, 2-6
RF IN Connector (J7), 2-9
RF OUT Connector (J6), 2-9
RFTA Remote Interface Connector J4 Pinout Description,
3-12
RFTB Remote Interface Connector, 3-13
RFTB Remote Interface Connector J5 Pinout Description,
3-13
RJU-2000 Block Diagram, 3-9
RJU-2000 Description, 3-9
RJU-2000 Front Panel, 3-8
RX B Online Indicator, 3-15
RX MON Connector (J5), 2-9
RX Switch Connector (J2), 3-10

S

S to Ku-Band Up Converter Module, 3-26
Selectable Monitor and Control (M&C):, 1-5
Single Thread KST-2000A System, 1-6
Single Thread KST-2000B Block Diagram, 1-8
Single Thread KST-2000B System, 1-8
Single Thread System Components, 2-1
System Transmit Characteristics, 1-11

T

TX Switch Connector (J1), 3-10

U

Up Converter Description, 3-25