

# MBT-4000 and MBT-4000B Multi-Band RF Transceivers



## INTRODUCTION

Comtech EF Data's MBT-4000 Multi-Band RF Transceiver is designed to perform C, X, Ku or Ka RF to L-Band down conversion and L-Band to C, X, Ku or Ka RF up conversion. Additionally, the MBT-4000 provides the following features:

- RF band switching in minimal time without requiring tools
- Minimal cost for a complete system including spares
- Easy expansion for providing a redundant system or other frequency bands
- Rugged construction for mobile and transportable applications
- Automatic band identification for the BUC, BDC, and antenna feed (if the feeds provide an identifying connector)
- Easy system status verification via LEDs located behind a removable cover
- Flexible configuration:
  - 2 Ups
  - 2 Downs
  - 1 Up and 1 Down

## SYSTEM OVERVIEW

The transceiver is constructed in a modular configuration. Common to the configuration for any frequency band of operation is a base module, which provides the M&C, Power Supply, and Reference function. Band-specific BUC and BDC modules can be quickly mounted to the base module with clip type fasteners. BUC and BDC modules for other bands and spares for all modules are stored in a transit case until needed.

## INSTALLATION AND OPERATION

The Common Module may be near or on the antenna. The band specific BUC and BDC is latched into place on top of the Common Module (M&C, Power Supply, and Reference). The cables to the antenna and the IDU complete the installation. To change the band of operation the cables to the BUC and BDC are removed and the clips released to allow the removal and replacement of the BUC/BDC with appropriate band-specific modules.

## LNB SUPPORT

The MBT 4000B provides a cost effective solution where LNB performance is sufficient. The base unit provides bias and a 10 MHz reference for the OMT mounted LNB. The LNB amplifies and translates a band specific input frequency block (C band or one of three Ku bands) down to L-Band in the 950 to 2000 MHz range. Because of the design of the MBT 4000B base unit, neither DC nor 10MHz are required from the modem.

## BLOCK DOWN CONVERTER (BDC-4000)

The BDC-4000 translates a band specific input frequency block (C, X, or Ku), from the LNA, down to L-Band (950 to 2000 MHz).

### BDC-4000C, X, Ku, Ka

C-Band:	3400 to 4200 MHz
X-Band:	7250 to 7750 MHz
Ku-Band:	10.95 to 12.75 GHz
Ka-Band:	20.20 to 21.20 GHz

"No spectral inversion for X-, Ku-, and Ka-Band, selectable inversion for inverted C-Band Block Down Converter when part of DCS 4000 system."

- 10 dB gain adjustment

## BLOCK UP CONVERTER (BUC-4000)

The BUC-4000 translates the LBC-4000 L-Band output carrier to the desired output frequency(C, X, or Ku) with an output level capable of driving an HPA.

### BUC-4000C, X, Ku, Ka

C-Band:	5850 to 6650 MHz
X-Band:	7900 to 8400 MHz
Ku-Band:	13.75 to 14.50 GHz
Ka-Band:	30.00 to 31.00 GHz (Future)

- No spectral inversion
- 10 dB gain adjustment

## COMMON FEATURES

- Meets or exceeds MIL-STD-188-164A
- Low phase noise
- Auto band sensing capability

# MBT-4000 and MBT-4000B Multi-Band RF Transceiver

## BUC-4000 Block Up Converter ODU

Input Frequency Range	950 to 2000 MHz
Output Frequency By Model:	
BUC-4000C	5850 – 6650 MHz
BUC-4000X	7900 – 8400 MHz
BUC-4000Ku	13.75 – 14.50 GHz
BUC-4000Ka	30.00 – 31.00 GHz
	27.50 – 28.50 GHz (optional)
	28.50 – 29.50 GHz (optional)
	29.50 – 30.10 GHz (optional)
Input/Output Impedance	50Ω
Input Return Loss	15 dB minimum
Output Return Loss	18 dB minimum
Input Connector	Type – N, female
Output Connector	N, Female (C-, X-, and Ku-Band)
Gain	15 dB nominal at minimum attenuation (18 dB for Ku-Band BUC)
User Attenuation Range	0 to 10 dB
Output Power, P1dB	+10 dBm minimum
Third Order Intercept	+20 dBm minimum
Carrier Spurious	-60 dBc
Non-Carrier Spurious	-60 dBm

## Environmental and Physical

Operating Temperature:	
ODU: BUC-4000	-40° to +50°C (-40° to 122°F)
IDU: LBC-4000	-10° to +50°C (14° to 122 °F)
Operating Humidity	5 to 95 non-condensing
Operating Altitude	10,000 ft above sea level
Non-Operating Temperature:	
ODU: MBT-4000	-50° to +71°C (58° to 160°F)
Prime Power	90 to 260 VAC, 47 to 63 Hz
Size	Refer to the manual
External Reference Input	Either 5 or 10 MHz ±5 dBm optional
Frequency Stability	1x10 <sup>-9</sup> /day, 1x10 <sup>-7</sup> /year 40° to +55°C 1x10 <sup>-8</sup> /Temperature

Typical Tx/Rx Redundant System  
(1:2 splitters/combiners may be substituted for the L-Band Input/Output switches)

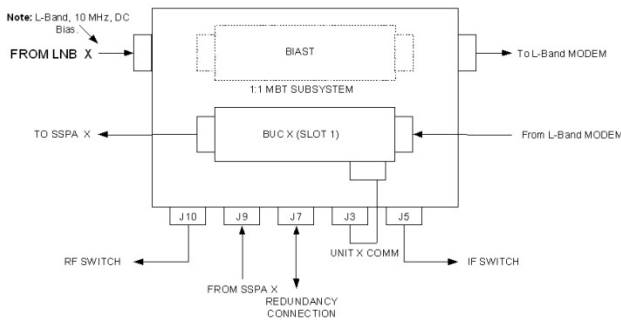

## BDC-4000 Block Down Converter ODU

Input Frequency By Model:	
BDC-4000C	3400 to 4200 MHz
BDC-4000X	7250 to 7750 MHz
BDC-4000K	10.95 to 12.75 GHz
BDC-4000Ka	20.20 to 21.20 GHz
	17.70 to 18.70 GHz (optional band)
	18.70 to 19.20 GHz (optional band)
	19.20 to 20.20 GHz (optional band)
Output Frequency Range	950 to 2000 MHz
Input/Output Impedance	50Ω
Input Return Loss	18 dB minimum
Output Return Loss	15 dB minimum
Input Connector	N, Female (C-, X-, and Ku-Band)
Output Connector	N, Female
Gain	15 dB nominal at minimum attenuation
User Attenuation Range	0 to 10 dB, in 0.25 dB steps (0.1 dB opt)
Output Power, P1dB	+ 12 dBm minimum
Third Order Intercept	+ 22 dBm minimum
Carrier Spurious	-60 dBc
Noise Figure	15 dB max @ 0 dB attenuation

## Typical LNB Characteristics (MBT-4000B)

LNB Input Frequency By Model:	
C Band Input Frequency	3.625 to 4.200 GHz
Noise Figure	≤ 35°K.
Ku Band Input Frequency	10.95 to 11.70 GHz
Options	11.70 to 12.20 GHz 12.25 to 12.75 GHz
Noise Figure	1.0 dB max
Output Frequency Range	950 to 2000 MHz(depends on RF band)

MBT-4000B

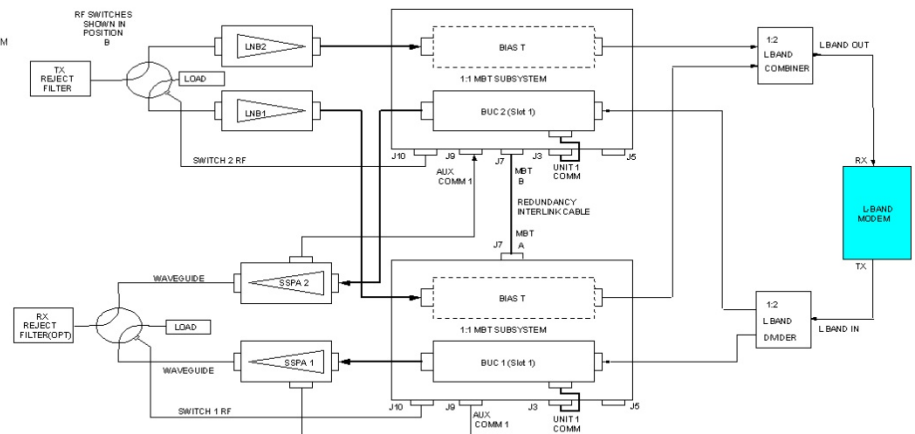

COMTECHEFDATA

DUAL MBT - 4000B REDUNDANT SWITCH



Advanced Communication Solutions

**COMTECH**  
RF DATA  
www.comtechefdata.com