



Challenges and opportunities for 3G backhaul over satellite

Demand is rising exponentially for mobile broadband and 3G services in regions of the world served only by satellite. This is being driven by desire for access to social networking and multimedia applications. However, bandwidth is expensive and network performance can be limited. Comtech EF Data presents this exclusive whitepaper on the challenges and opportunities for 3G backhaul over satellite and illustrates how innovative technology can overcome these issues.

Very few people believed in the value of satellite backhaul for providing mobile services in rural regions and in developing countries until early 2002. Since then, mobile telephony has spread and reached out to countries where the GDP level did not seem sufficient at first to allow people to acquire mobile devices and pay for subscription packages.

The practicality of mobile telephony, combined with newer types of usage (SMS) and business models (flat rates), the affordability of low-cost (refurbished) handsets and the adoption of government regulations for universal coverage have led to tremendous demand for mobile services in those areas, served by satellite links. The same pattern is expected to repeat itself as

3G takes hold across developing countries. Markets are opening up faster than ever, as demonstrated by the key role social media via mobile devices is playing in supporting current civilian actions across the Middle East. 3G networks are currently being rolled out at expedited speeds across Africa. These events provide only a glimpse of the potential usage requirements expected as the popularity of iPhone®, Blackberry®, and other smartphones continue to increase. But how will 3G services be deployed over the next few years, and what role will satellite play in the future for backhauling of 3G base stations?

In order to assess where 3G satellite backhaul could fit, let's first picture how and where 3G services are, or will be, deployed

in developing countries. If we examine expected usage patterns over the next 2-3 years, it becomes evident that 3G mobile broadband traffic growth will be concentrated in key areas:

- **Urban Centres:** This is the obvious, populated with higher ARPU, tech-savvy and business users.
- **Hot Spots:** Resorts, mining camps, isolated remote urban areas (>400 km from a main city). A typical example is the vacation resort. The tourists will resemble the usage behaviours of tech-savvy users with high purchasing power. They will use smartphones, laptops and/or tablets equipped with 3G USB dongles.



- **“Bridging the digital divide” government sponsored programs (Universal Service Obligation or Educational):** In these cases, mobile broadband access is used in a nomadic form for Internet access instead of conventional terrestrial (unavailable) means. This can be illustrated with the prominent village leaders who will likely rely upon 3G USB dongles and satellite backhaul services because there is no connectivity in the village. They may also offer or resell VoIP service to other villagers, but may not even be using smartphones.

The power and efficiency of the backhaul BAN infrastructure is critical to supporting 3G mobile broadband traffic requirements. While a fibre infrastructure is a sure-fire method of supporting demand, it is not ubiquitous; it is costly in time and financial resources to deploy. And, in many developing regions, it does not take long before it is cut off by vandals or due to negligence.

For these reasons, the cases of 3G hot spots and mobile broadband USO deployment will likely be served by satellite links, while metro areas will be served by a combination of fibre and short-range, new generation, high-capacity Ethernet microwave links.

Another factor to consider is the potential of newer generation base stations. The progress made in spectral efficiency, energy consumption and overall cost is likely to drive deployments in less populated and remote/rural areas.

The current trend of outsourcing operations and the availability of substantially lower cost equipment will generate a rationalization and replacement of older units, justified by the lower operation costs of these new generation BTSs. By the same token, the new BTSs are also technology agnostic and equally 2G/3G/4G capable (software defined

radios), allowing mobile operators to offer 3G and mobile broadband services at a minimum incremental cost from a radio point of view.

There is also an increasing trend amongst consumers to move away from SIVIS communications and access social media sites using 3G enabled semi-smartphones, which is the case in the Philippines and Indonesia. And, while only a relatively small portion of these countries’ populations can currently afford smartphones, many will seek high-speed Internet access via Internet cafes and refurbished PC/laptops using dongles that will deliver greater levels of data traffic on their networks.

As a result, it is very likely that the deployment of 3G mobile broadband in remote and rural areas served by satellite links today will happen much faster than initially anticipated. Driving forces are pressures from the device market and from the user community, and facilitated by the embedded readiness of the radio network.

This situation raises some specific challenges when considering satellite backhaul deployment:

- First, the amount of bandwidth needed by mobile broadband applications will potentially be a show stopper for enabling such services given the cost of satellite transponder capacity. Therefore, a new backhaul paradigm different from the widely used point-to-point SCPC satellite link model will be needed to offset this additional bandwidth amount and associated operation costs.
- Secondly, mobile broadband applications are often very delay sensitive. Although the satellite delay cannot be overcome, there are technologies ready to be deployed which can help mitigate the delay affect for most common applications.
- More importantly, when considering rural deployment, literacy is most likely to be the key issue that could slow down the deployment of 3G mobile broadband services. Yet, one shall not underestimate the cleverness of these young populations as demonstrated with the case of the widespread usage today of Twitter in the Philippines and Facebook in Indonesia.

- Last but not least: device cost. The exponential growth of 2G mobile [voice] services really kicked-off in developing countries like Africa only after manufacturers made available low price handsets to consumers combined with the availability of second-hand handsets. There are no reasons not to believe though that the same phenomenon will repeat with smartphones and other mobile computing devices.

Nokia, for example, already started such an initiative of a low cost “semi-smartphone” targeted at the Indian market.

To alleviate or mitigate the first two challenges identified above, hereafter is a snapshot of a few technologies available today, grouped together by category and focused on the deployment of 3G and mobile broadband services outside mainstream urban areas:

Inspection and policy

These technologies are used to filter out unwanted applications (like peering) and limit/regulate bandwidth consumption from heavy users.

The objective of these technologies is to control the affect of “bandwidth-hog” users who can consume up to 90 percent of the network capacity. This is particularly applicable on limited satellite access links. The technologies are embedded in network device(s) located at the entry point of the application and Internet data traffic into the mobile packet core, i.e. co-located to the GGSN:

- Deep Packet Inspection (DPI) — The DPI function analyzes the traffic and then filters out unauthorized applications from the network (e.g. VoIP in some countries). (See Diagram 1)
- Policy and Charging Rules Function (PCRF) — In order to avoid known situations where one percent of users use 90 percent of the network bandwidth capacity, the PCRF function ensures that only those who pay for premium service get what they paid for, while typical users are applied fairness access rules.

RAN Acceleration and Caching

These technologies are used to mitigate the affect of satellite delay in terms of user ex-



Author: Yves Hupe is President of Memotec a subsidiary of Comtech EF Data.

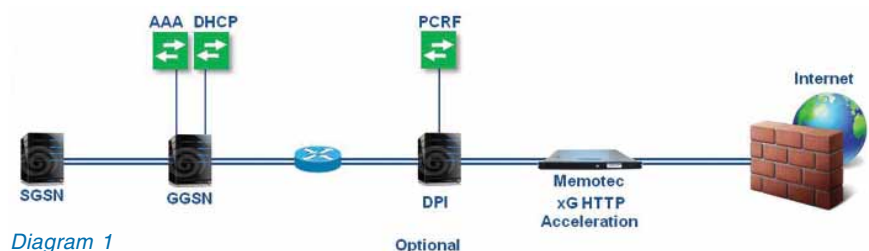



Satellite Backhaul

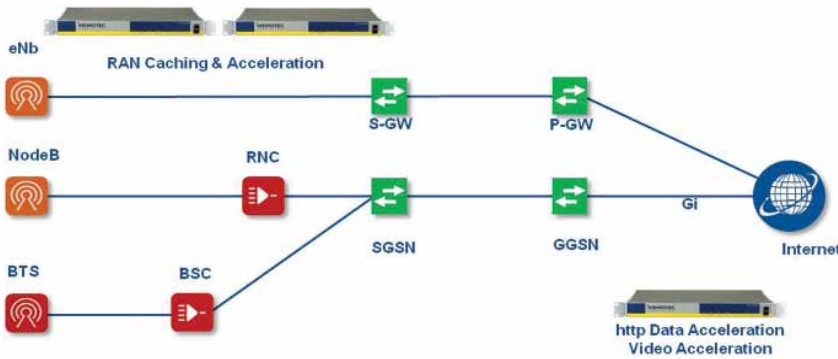

Diagram 2

perience (except for real-time interactive applications like gaming), and also participate in reducing the overall bandwidth demand. They may be located either next to the GGSN, or in the RAN, depending on the targeted mobile service (2G, 3G or HSPA/4G) and scope of application (whole network or only the portion served by satellite links).

- **Web Acceleration** — HTTP acceleration/compression enhances Internet browsing, email transmissions, document downloading and social media by accelerating the loading of multimedia content. (See Diagram 2)
- **Video Acceleration** — To conserve bandwidth during peak traffic times, video acceleration controls the downloading of video (using transcoding, transrating, resizing, and decimation technologies), adjusted to real-time network status and usage.
- **Caching** — To conserve bandwidth, caching intelligently monitors frequently accessed files (even if they have changing URLs) and then stores/caches them at the edge of the RAN. The user experience is enhanced with accelerated uploads and downloads.

Satellite technologies

Peak bandwidth requirements to serve a 3G base station (BTS) in the same area is typically around 4 to 8 times (8 Mbps vs. 1 to 2 Mbps) the bandwidth required by a 2G BTS.

But, as much as voice traffic is essentially symmetrical in nature, mobile broadband traffic is mainly asymmetrical, with most of the bandwidth demand being on the down (hub to remote) path. In addition, data traffic — in particular, non-streaming video — is far more bursty than voice traffic. Data traffic is not necessarily focused within a peak hour and can be rather spread out in time and space (geographically). Therefore, point-to-point network topologies are not best suited anymore when deploying 3G and mobile broadband services. A point-to-multipoint (or rather hub and spoke) topology is the best solution, where the

downpath traffic to all the remote sites can be statistically multiplexed spatially and temporally, taking advantage of the inherent bursty nature of such traffic.

New, advanced satellite modems based on enhanced, low overhead DBV-S2 downlink coding are available that have been specifically designed to accommodate such architecture and provide substantial performance. Combined with other techniques, such as IP header and payload compression, Adaptive Coding & Modulation (ACM) and Group QoS, the actual needed transponder capacity for the downstream path can be managed within the same range as a traditional 2G point-to-point network.

When considering the return or uplink path (from the remote site to the hub), the three key parameters are jitter, link resilience to errors and power. Power is the most costly and rare resource in most locations served by satellite links. Jitter and link resilience are also important as voice and signalling traffic still co-exist with data applications, which are adverse to excessive delay/jitter and packet loss, which results in degraded KPIs and voice quality.

For these reasons, using dedicated SCPC return paths from each remote remains the most efficient solution to carry both 2G and 3G services, compared to alternative VSAT-based offerings. In addition, using SCPC dedi-

cated return paths combined with newer Forward Error Correction (FEC) techniques, such as our VersaFEC®, enables further optimization and reduction of power requirements. The result is the reduction in satellite backhaul costs, which can include both CAPEX (power, antenna and/or RF amplifier) and OPEX (energy). (See Diagram 3)

Conclusion

We have seen that there is a demand today for deploying 3G/mobile broadband services in areas which can only be served by satellite links (hot spots, USO programs). This demand will likely happen much faster and on a broader scale than initially anticipated, pushed by consumer usage (multimedia social media), technology readiness (Multi-service Software Defined Radio BTS), and other factors, such as energy savings (OPEX/CAPEX) from newer generation BTSs. However, the rollout of 3G mobile broadband services in remote and rural areas faces several challenges, including the cost of computer-enabled devices, literacy, latency and the cost of satellite bandwidth.

While it is expected that the first two challenges would quickly be resolved over time, technologies are available today that, when combined, can overcome the last two technical challenges and deliver economically sound, cost efficient and workable 3G satellite backhaul solutions.

The expanding availability of 3G combined with specific usage patterns will drive traffic and revenue in rural regions and developing countries. Addressing these requirements demands hands-on expertise in satellite communications and mobile infrastructure that very few companies possess. Since 2000, we have delivered market-leading satellite solutions based on our advanced modem and bandwidth optimization techniques. Working closely with partners and customers worldwide, we developed an extensive product portfolio that addresses real deployments and market requirements while respecting budget and performance considerations. Put them to work in your network!

Diagram 3

