



### Application

The Comtech EF Data (CEFD) UT-4505/X Up Converter is the ultimate in high performance and cost effective C-Band frequency conversion. The UT-4505/X can be used for SCPC, DAMA, and TDMA, as well as full transponder HDTV and analog TV. Spectral purity and stability characteristics fully meet or exceed the requirements of all domestic, international, and regional commercial satellite networks.

### High Gain

The UT-4505/X has +17 dBm minimum output level at the 1 dB compression point and 35 dB of gain as a standard. These standard capabilities permits longer cable runs to the high power amplifier or compensates for elaborate combining networks without adding expensive options such as external line amplifiers.

### Low Phase Noise

The phase noise performance of the UT-4505/X exceeds the Intelsat phase noise mask for IBS and IDR services by more than 9 dB. This allows phase dependent demodulators to perform better. The close-in phase noise is very low, making the converter ideal for low bit rate digital circuits such as those used in DAMA hub earth stations.

### Daisy Chain Redundancy Switching

The converter uses our patented "Daisy Chain" integrated switching technology. The Daisy Chain design removes the relays associated with a centralized protection switch tray and distributes them across the individual converters. Daisy Chain technology successfully eliminates a central switching chassis, two power supplies, a microprocessor, and several long, costly cables. Widely accepted in the industry, CEFD's Daisy Chain provides both pricing and marketing advantages.

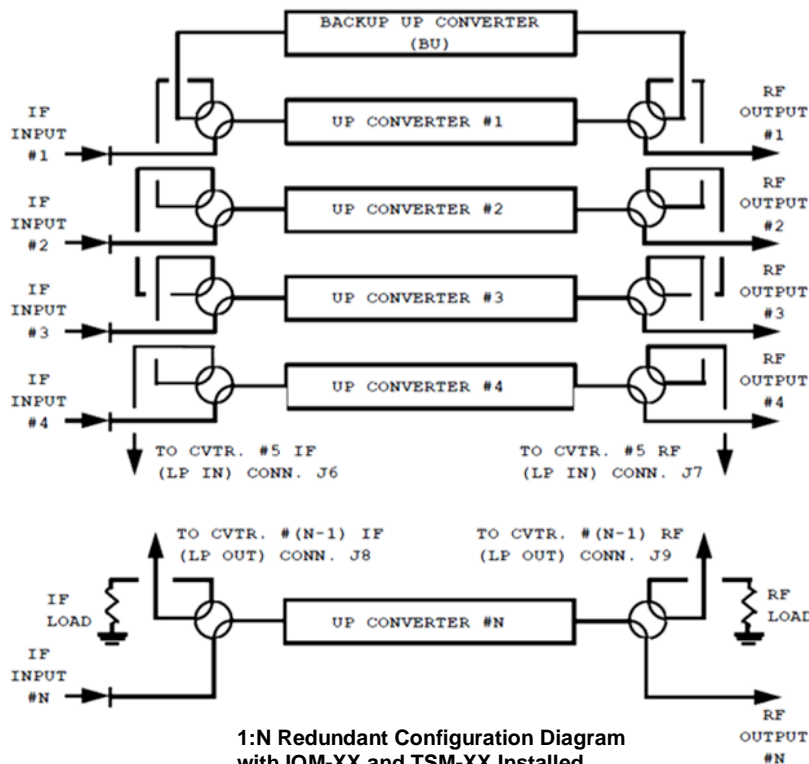

1:N Redundant Configuration Diagram  
with IOM-XX and TSM-XX Installed

## Remote Control

The remote control interface is selectable between EIA-232 and EIA-485, as well as full Ethernet including Telnet, SNMP and pre-loaded HTML GUI. All configuration control, status retrieval, and adjustments are available as simple ASCII commands through the serial interface or through the front panel menu. As a cost option, the remote control command structure can be customized in order to accommodate existing network control software.

## Detachable RF/IF Connector Module

Each UT-4505/X is equipped with a detachable I/O Module (IOM) that establishes input and output connection types. The module inserts into a rear compartment of the converter, and requires no additional outside space. The IOM includes a Type N connector for the RF path and a BNC connector at 50 or 75  $\Omega$  for the IF path.

## Minimum Rack Space

Due to its small rack height (1.75 inches) and the elimination of the space penalty paid for a separate 1+N switch chassis, the UT-4505/X and the Daisy Chain switch architecture provide the most compact and cost effective converter subsystem available. The units are ideal for the construction of transportable systems such as "flyaways," and high capacity earth stations where space utilization and economy are prime considerations.

## Specifications

Frequency Range	
UT-4505	5845 to 6425 MHz
UT-4505/E	6725 to 7025 MHz
UT-4505/F	6425 to 6725 MHz
UT-4505/G	5925 to 6725 MHz
UT-4505/H	5850 to 6650 MHz
UT-4505/J	7025 to 7075 MHz
UT-4505/K	5725 to 6425 MHz
UT-4505/M	5725 to 6725 MHz
UT-4505/N	5845 to 6475 MHz
Conversion	Dual, No Inversion
Step Size	125 kHz standard, 1 kHz optional
Preset Channels	32 frequencies and gains
Stability Over Time	$\pm 1 \times 10^{-9}$ /Day
Stability Over Temp	$\pm 1 \times 10^{-8}$ 32 to 122°F (0 to 50°C)

### IF Input

Noise Figure	12 dB Maximum at 0 dB Attenuation
Level	-35 dBm Typical
Range	52 to 88 or 104 to 176 MHz Optional 50 to 90 MHz or 100 to 180 MHz (Contact factory with specific requirements)
Impedance	50 or 75 $\Omega$
Return Loss	23 dB Minimum with IO Module or Switch Module

### RF Output

Output Level	+17 dBm at 1 dB Compression
Intermodulation	-50 dBc @ 0 dBm Output SCL
Carrier Mute	-70 dBc
Non-Carrier Spurious	-80 dBm
Carrier Spurious	-65 dBc @ 0 dBm Output
AM to PM	0.1°/dB at -5 dBm Out
Return Loss	20 dB Minimum with I/O Module
Impedance	50 $\Omega$

### Transfer

Gain	35 dB $\pm$ 2 dB
Attenuation Adjust	0 to 25 in 0.25 dB Steps 0.1 dB Steps Optional
Gain Stability	$\pm$ 0.25 dB/Day
Ripple	$\pm$ 0.25 dB ( $\pm$ 18 MHz) Optional $\pm$ 20 MHz 0.75 dB ( $\pm$ 36 MHz) Optional $\pm$ 40 MHz (Contact factory with specific requirements)
Slope	0.05 dB/MHz
IF Bandwidth	36 or 72 MHz, Optional 40 or 80 MHz (Contact factory with specific requirements)

### External Reference

Input, either 5 or 10 MHz Option @ +3 dBm  
Optional 10 MHz Rear Panel Reference Output

### Group Delay

Linear	0.03 ns/MHz
Parabolic	0.01 ns/MHz <sup>2</sup>
Ripple	1.0 ns Peak-to-Peak

### Phase Noise

	Limit (dBc/Hz)		Typical (dBc/Hz)	
	UT-4505	UT-4505/X	UT-4505	UT-4505/X
100 Hz	-80	-69	-83	-72
1 KHz	-89	-79	-92	-82
10 KHz	-95	-89	-97	-92
100 KHz	-105	-99	-109	-102
1 MHz	-120	-109	-124	-112

### Remote Control (Rear Panel)

Comm Port RS-485 or RS-232C, RJ-45 for Ethernet

### Indicators (Front Panel)

Power On	Green LED
Mute	Yellow LED
Remote	Yellow LED
Reference	Yellow LED
Stored Fault	Red LED
Fault	Red LED

### Test Points (Front Panel)

RF Sample	SMA, -20 dBc Nominal
IF Sample	BNC, -20 dBc Nominal
Optional L.O. Sample	

### Power

Voltage	90 to 250 VAC Auto ranging, optional -48 VDC
Frequency	47 to 63 Hz
Dissipation	60 W

### Environmental

Temperature	32 to 122°F (0 to 50°C)
Altitude	10,000 Feet MSL
Humidity	0 to 95% Relative Humidity

### Physical

Dimensions (1RU) (height x width x depth)	1.75" x 19" x 22" (4.45 x 48.30 x 55.90 cm)
Weight	15 lbs (7.0 kg)

### MTBF

49,740 hrs (calculated)  
> 100,000 hrs. (field experience)

### Summary Alarm

Relay Closure | Form C



2114 West 7th Street, Tempe, Arizona 85281 USA  
Voice: +1.480.333.2200 • Fax: +1.480.333.2540 • Email: sales@comtechefdata.com



See all of Comtech EF Data's Patents and Patents Pending at <http://patents.comtechefdata.com>

Comtech EF Data reserves the right to change specifications of products described in this document at any time without notice and without obligation to notify any person of such changes. Information in this document may differ from that published in other Comtech EF Data documents. Refer to the website or contact Customer Service for the latest released product information.