



Ku-Band Power Amplifier with Optional L-Band

Operation Manual

IMPORTANT NOTE: The information contained in this document supersedes all previously published information regarding this product. Product specifications are subject to change without prior notice.

Errata A

Comtech EF Data Documentation Update

Subject: Changes to Chapter 3 Operation

Date: April 26, 2006

Original Document Part Number/Rev: MN/ODPA.IOM Rev 0

Errata Part Number: MN/ODPA.EA0

This information will be incorporated into the next revision.

Change Specifics:

Add Table 3-1.

Table 3-1. LO, MIX and Mod Spectrum Settings for Modulator And BUC

P1dB_min	Band	RF Start Frequency (GHz)	RF End Frequency (GHz)	LO (Offset) Freq. (MHz)	Mix (+/-)	Modem Spectrum (Utility Modulator Menu)	BUC Supply Voltage
8 Watt	Ku	14.00	14.50	13,050.00	+	Normal	24 VDC
16 Watt	Ku	14.00	14.50	13,050.00	+	Normal	24 VDC
25 Watt	Ku	14.00	14.50	13,050.00	+	Normal	24VDC
32 Watt	Ku	14.00	14.50	13,050.00	+	Normal	24VDC
40 Watt	Ku	14.00	14.50	13,050.00	+	Normal	24 VDC





Errata B

Comtech EF Data Documentation Update

Subject: Replace 32/40 Watt ODP A Equipment Outline (Non L-Band)
Dimensional Drawing

Date: November 24, 2004
Original Document MN/ODPA.IOM Rev 0

Part Number/Rev:
Errata MN/ODPA.EB0

Part Number: Replace Figure A-4, page A-5 with the following:

Change Specifics:

This information will be incorporated into the next revision.

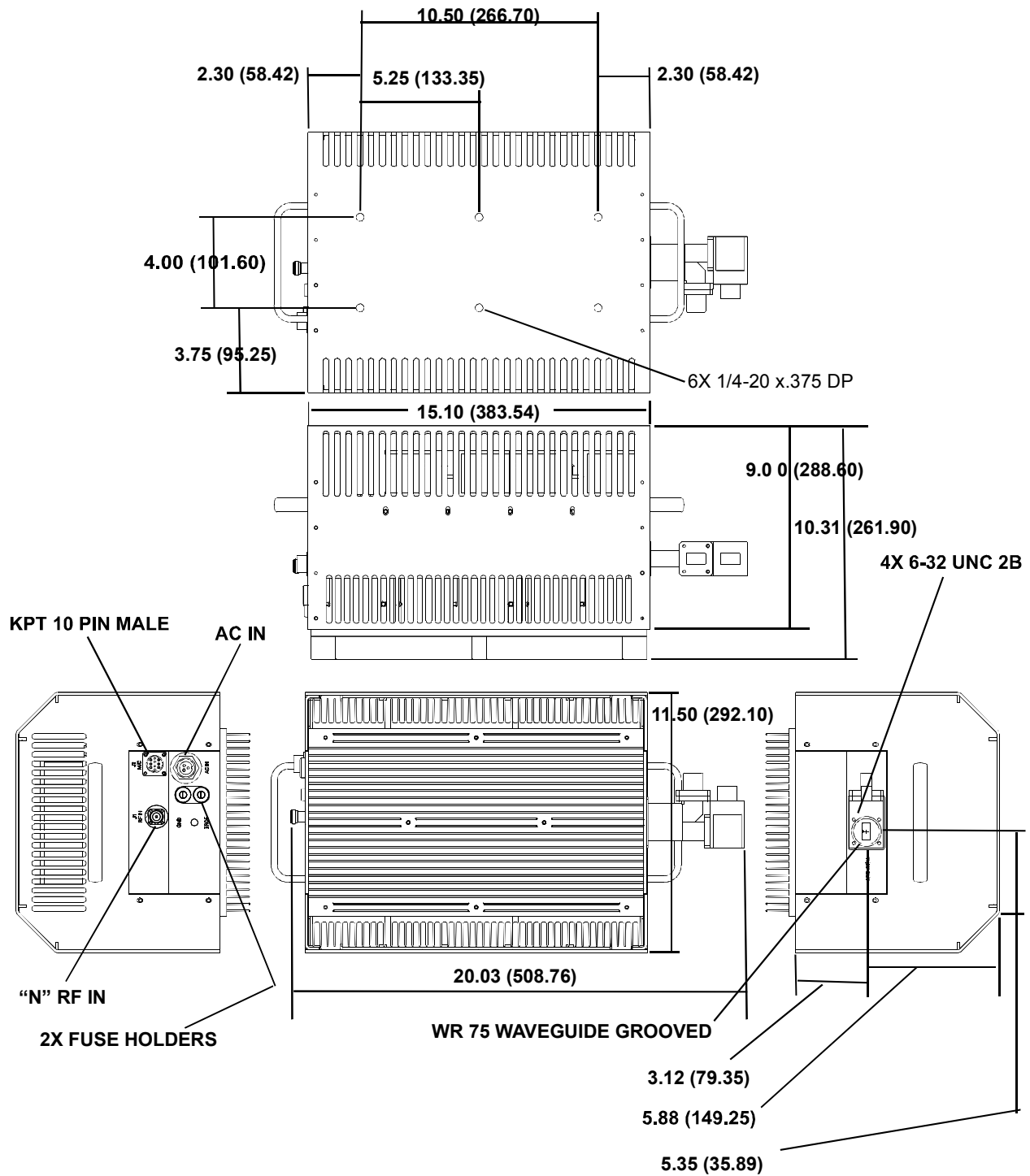



Ku-Band Power Amplifier with Optional L-Band

Operation Manual

Comtech EF Data is an ISO 9001
Registered Company.

Part Number MN/ODPA.OM
Revision 0
October 4, 2004



Customer Support

Contact the Comtech EF Data Customer Support Department for:

- Product support or training
- Information on upgrading or returning a product
- Reporting comments or suggestions concerning manuals

A Customer Support representative may be reached at:

Comtech EF Data
Attention: Customer Support Department
2114 West 7th Street
Tempe, Arizona 85281 USA

480.333.2200 (Main Comtech EF Data Number)
480.333.4357 (Customer Support Desk)
480.333.2161 FAX

or, E-Mail can be sent to the Customer Support Department at:

service@comtechedata.com

Contact us via the web at www.comtechedata.com.

1. To return a Comtech EF Data product (in-warranty and out-of-warranty) for repair or replacement:
2. Request a Return Material Authorization (RMA) number from the Comtech EF Data Customer Support Department.
3. Be prepared to supply the Customer Support representative with the model number, serial number, and a description of the problem.
4. To ensure that the product is not damaged during shipping, pack the product in its original shipping carton/packaging.
5. Ship the product back to Comtech EF Data. (Shipping charges should be prepaid.)

For more information regarding the warranty policies, see Warranty Policy, p. vii.

Table of Contents

CHAPTER 1. INTRODUCTION	1-1
1.1 Description	1-1
1.2 System Block Diagram	1-2
1.3 Functional Description	1-2
1.4 Specifications.....	1-2
CHAPTER 2. MOUNTING	2-1
2.1 Installation.....	2-1
2.2 Mounting Kit PL/7725-1/-2	2-1
2.3 Mounting Kit PL/8094-1	2-4
2.4 External Connectors.....	2-6
CHAPTER 3. OPERATION	3-1
3.1 Operation.....	3-1
3.2 M&C Pinout Configuration.....	3-1
3.3 Theory of Operation.....	3-2
APPENDIX A. EQUIPMENT OUTLINE DRAWING.....	A-1

This page is intentionally left blank.

About this Manual

This manual provides installation and operation information for the Comtech EF Data Ku-Band Power Amplifier with Optional L-Band, herein after referred as the Outdoor Power Amplifier (ODPA). This is a technical document intended for earth station engineers, technicians, and operators responsible for the operation and maintenance of the ODPA.

Safety Notices

This equipment has been designed to minimize exposure of personnel to hazards. The operators and technicians must:



- *Know how to work around, with, and on high voltage and high RF power level equipment.*
- *Exercise every precaution to ensure personnel safety.*
- *Exercise extreme care when working near high voltages/high RF power level equipment.*
- *Be familiar with the warning presented in this manual.*
- *Disconnect the power supply cord before servicing the SSPA.*

Lithium Battery Replacement



There is a possibility that the Lithium battery on the M&C assembly will explode if the battery is incorrectly replaced. Observe all instructions from the battery manufacturer. Replace only with the same or equivalent type battery recommended by the manufacturer. Dispose of used batteries according to the Lithium battery manufacturer's instructions.

Metric Conversion

Metric conversion information is located on the inside back cover of this manual. This information is provided to assist the operator in cross-referencing English to Metric conversions.

Trademarks

Windows is a trademark of the Microsoft Corporation.

Other product names mentioned in this manual may be trademarks or registered trademarks of their respective companies and are hereby acknowledged.

Reporting Comments or Suggestions Concerning this Manual

Comments and suggestions regarding the content and design of this manual will be appreciated. To submit comments, please contact the Comtech EF Data Technical Publications Department: techpubs@comtechedata.com



European EMC Directive

In order to meet the European Electro-Magnetic Compatibility (EMC) Directive (EN55022, EN50082-1), properly shielded cables for DATA I/O are required. More specifically, these cables must be shielded from end-to-end, ensuring a continuous ground shield.

The following information is applicable for the European Low Voltage Directive (EN60950):

<HAR>	Type of power cord required for use in the European Community.
	CAUTION: Double-pole/Neutral Fusing ACHTUNG: Zweipolige bzw. Neutralleiter-Sicherung

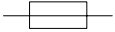
International Symbols:

	Alternating Current.
	Fuse.
	Safety Ground.
	Chassis Ground.

Note: For additional symbols, refer to “Cautions and Warnings” listed earlier in this preface.

Warranty Policy

This Comtech EF Data product is warranted against defects in material and workmanship for a period of 2 years from the date of shipment. During the warranty period, Comtech EF Data will, at its option, repair or replace products that prove to be defective.

For equipment under warranty, the customer is responsible for freight to Comtech EF Data and all related custom, taxes, tariffs, insurance, etc. Comtech EF Data is responsible for the freight charges **only** for return of the equipment from the factory to the customer. Comtech EF Data will return the equipment by the same method (i.e., Air, Express, Surface) as the equipment was sent to Comtech EF Data.

Limitations of Warranty

The foregoing warranty shall not apply to defects resulting from improper installation or maintenance, abuse, unauthorized modification, or operation outside of environmental specifications for the product, or, for damages that occur due to improper repackaging of equipment for return to Comtech EF Data.

No other warranty is expressed or implied. Comtech EF Data specifically disclaims the implied warranties of merchantability and fitness for particular purpose.

Exclusive Remedies

The remedies provided herein are the buyer's sole and exclusive remedies. Comtech EF Data shall not be liable for any direct, indirect, special, incidental, or consequential damages, whether based on contract, tort, or any other legal theory.

Disclaimer

Comtech EF Data has reviewed this manual thoroughly in order that it will be an easy-to-use guide to your equipment. All statements, technical information, and recommendations in this manual and in any guides or related documents are believed reliable, but the accuracy and completeness thereof are not guaranteed or warranted, and they are not intended to be, nor should they be understood to be, representations or warranties concerning the products described. Further, Comtech EF Data reserves the right to make changes in the specifications of the products described in this manual at any time without notice and without obligation to notify any person of such changes.

If you have any questions regarding your equipment or the information in this manual, please contact the Comtech EF Data Customer Support Department.

Chapter 1. Introduction

1.1 Description

The Ku-Band Outdoor Power Amplifier (ODPA) provides higher output power than typically available in a block package. The optional L-Band Up Converter requires 24 VDC and a 10 MHz reference on the coax from an L-band modem.



Figure 1-1. 25-40 Watt High Power Ku-Band BUC

The SSPA portion is line powered and provides an analog interface for fault status and mute control.

The ODPA delivers up to 40 Watts, at the 1 dB compression point, to the transmit waveguide flange. It provides a cost-effective and reliable replacement for TWT amplifiers in Ku-Band terminals. Due to a small form factor, it is ideal for the construction of small “flyaway” terminals, Intelsat earth stations, and hub earth stations for small- to medium-size private networks or point-to-point links.

1.2 System Block Diagram

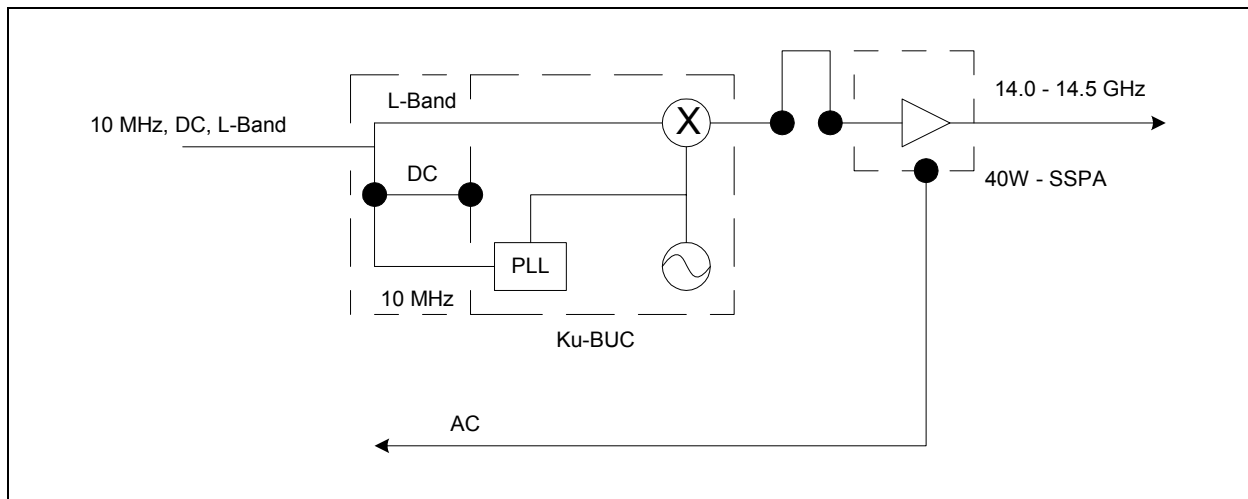

Figure 1-2. System Block Diagram

1.3 Functional Description

The ODPA consists of a chassis, power supply, fan assembly, Monitor and Control Processor (MCP) and a Comtech EF Data SSPA module. The amplifier is designed using a Comtech EF Data low loss combining technique and an MCP based temperature versus gain compensation.



1.4 Specification

Characteristics

Input Frequency - IF	950 to 1450 MHz
Output Frequency Range	14.00 – 14.50 GHz
	Optional: 13.75 to 14.50 GHz
Max. Input Power without damage	(ODPA) +15 dBm

	ODPA	ODPA w/L-Band
	8W +33 dB	8W + 63 dB
	16W +36 dB	16W +66 dB
	25W +40 dB	25W +68 dB
	32W +42 dB	32W +69 dB
	40W +44 dB	40W +70 dB

Gain Flatness over Full Band	(ODPA) ± 1.0 dB max
	(ODPA w/L-Band) ± 2.5 dB nominal

Gain Variation over 36Mhz	± 1.0 dB
Gain Variation (ODPA) ± 1.0 dB over operating temperature range	
Gain Stability over Temperature	(ODPA w/L-Band) ± 2.5 dB
Gain Slope	(ODPA) 0.5 dB/40 MHz max
Noise Figure at max Gain	10 dB

Power Output @1dB	
Compression @ 25°C:	8W +39dBm
	16W +42 dBm
	25W +44 dBm
	32W +45 dBm
	40W +46 dBm

3 rd Order Intercept Point:	8W +47 dBm
	16W +50 dBm
	25W +52 dBm
	32W +53 dBm
	40W +54 dBm

3 rd Order IMD: -34 dBc @ 6dB backoff (SCL 9 dB backoff from P1 dB)	
-28 dBc @ 3dB backoff (SCL 6 dB backoff from P1dB)	

Input/Output Return Loss	18 dB minimum
Spurious (in-band) at Rated Power	(ODPA) -50 dBc maximum
Spurious at Rated Power	(ODPA) -65 dBc max
Spurious (Rx band) at Rated Power	-70 dBc maximum
Harmonics at Rated Power	(ODPA) -65 dBc max
AM/PM Conversion (ODPA) 2.5°/dB typical (@P1dB) and 3.0°/dB max	

Group Delay:	
Linear	0.02 nsec/NHz
Parabolic	0.003 nsec MHz ²
Ripple	1 nsec peak-to-peak

RF-Mute	-60 dB
---------	--------

Phase Noise	Limit (dBc/Hz)
300 Hz offset	-60
1 kHz offset	-70
10 kHz offset	-80
100 kHz offset	-90
1 MHz offs	-100

Front Panel

Display	20 x 2 LCD
Data Entry	Cursor Control Keypad
Output Sample	Type N, 50 Ω , -40 dBc

Required External Reference Signal

Required External Reference Signal	Frequency: 10 MHz
	Input Power: -5 to +5 dBm
Phase Noise:	-125 dBc/Hz max. @ 100Hz
	-135 dBc/Hz max. @ 1 kHz
	-140 dBc/Hz max. @ 10 kHz

L-Band (Optional)

Power Requirement:	+15 to +24 VDC
Power Consumption:	1.6 A max. @ +15V

System Power Requirements

ODPA Input Power. 85 - 264 VAC, 47 - 63 Hz	8W	150W
	16W	180W
	25W	360W
	32W	370W
	40W	390W

AC Input Voltage	110/220 VAC $\pm 15\%$ (47 to 63Hz)
	Auto Ranging, 12, 24, & 48 are optional

Mechanical Requirements

Interface: IF Input	Type N (F optional)
RF Output	WR75 *
M&C Analogue	MS3112E16-26P *
Power	(ODPA) MS3102R16-10P *
	Molex Custom (#84855 Series)

*Other options are available

Environmental

Temperature:	
Operating	-40° to 55° C. (-40° to 122° F)
Storage	(ODPA) -55° to 75° C (-67° to 167° F)
Humidity	100% condensing rain 2" per hour
Altitude	10,000 AMSL
Shock	Normal commercial shipping and Handling

Physical

Dimensional :	
8 and 16 Watt	ODPA 12.40 x 10.25 x 8.38 (32 x 26 x 21 cm)
	ODPA w/L-Band 12.4 0 x 10.25 x 10.25 (32 x 26 x 26 cm)
25 thru 40 Watt	ODPA 20.90 x 11.50 x 10.30(51 x 30 x 16 cm)
	ODPA w/L-Band 20.90 x 11.50 x 12.6 (51 x 30 x 32 cm)
Weight:	
8 and 16 Watt OPDA	27lbs (12.2 kg)
	ODPA w/L-Band Input 32 lb (14.5 kg)
25 thru 40 Watt ODPA	52 lb (24.0 kg)
	ODPA w/L-Band Input 61 lb (27.7 kg)

Chapter 2. Mounting

2.1 Installation

Mounting P/N	Nomenclature
PL/7725-1	Spar Mount. Prodelin
PL/7725-2	Spar Mount, Channel Master
PL/8094-1	Single-Thread Pole Mount





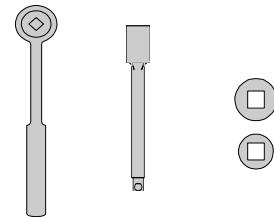

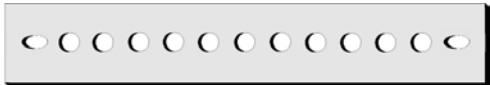

2.1.1 Tools Required

Qty.	Description
1	3/8" drive ratchet.
1	Adjustable wrench.
1	7/16" x 3/8" drive socket, or 7/16" drive wrench. (Metric equivalent: 12mm, 6 pt.)
1	1/2" x 3/8" drive socket, or 1/2" box wrench. (Metric equivalent: 13mm, 6 pt.)
1	5/16" box wrench, or nut driver
1	7/64" Allen wrench

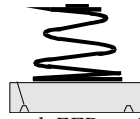

2.2 Mounting Kit PL/7725-1/-2

2.2.1 Spar Arm Mount

Kit PL/7725 includes:			
Qty.	Description	Qty.	Description
2	Spar support bracket.  <i>Comtech EFData Part # FP/3175. Used form Mounting Kit PL/7725-1 Spar Mount only.</i>	2	20" Unistrut  <i>Comtech EFData Part # FP/7582-1</i>
12	1/4-20 x 5/8" bolt.  <i>Comtech EFData Part # 03P1131 Used to Attach Unistruts to converters.</i>	4	5/16" flat washer  <i>Comtech EFData Part # HW/5/16-FLT</i>
16	1/4" flat washer.  <i>Comtech EFData Part # HW/1/4-FLT. Used to Attach Unistruts to converters.</i>	4	5/16" split washer  <i>Comtech EFData Part # HW/5/16-SPLIT</i>
16	1/4" split washer.  <i>Comtech EFData Part # HW/1/4-SPLIT. Used to Attach Unistruts to converters</i>	4	5/16"-18 spring nut  <i>Comtech EFData Part # HW/5/16-18SPNUT</i>
4	5/16-18 x 1.25" bolt.  <i>Comtech EFData Part # HW/5/16-18x1.25.</i>		

2.2.2 Mounting Instructions

PRODELIN 1.8, 2.4, and 3.8 M: Channel Master 2.4 and 3.8 M.











1. Position the two 20” Unistrut channels on the backside of the BUC box, aligning and centering the two center slots of the channel with the mounting holes of the BUC. Fasten with the 1/4” hardware (4 each bolts, split and flat washers).
2. Position the BUCs and mounting brackets facing upward, leaving a gap between roughly the width of the BUC. Ensure that all items are oriented correctly and fasten with the 1/4” hardware (twelve each bolts, split and flat washers).

Note: It may be necessary to loosen the hardware on the BUC in order to align the mounting holes between the Unistrut channels and the converter brackets.

3. (For SPAR Mount Kit PL/7725-1 only) Using a Spar support bracket as a guide, position two spring nuts in each of the Unistrut channels. The threaded holes in the spring nuts must be aligned with the holes in the Spar support brackets and should be centered in the Unistrut channels.
4. (For Spar Mount Kit PL/7725-1 only) Position the assembly on the Spar arm of the antenna and fasten the Spar support brackets to the spring nuts in the Unistrut with the 5/16” hardware (4 each bolt, split and flat washer).
5. Ensure that the assembly is mounted in such a manner as to provide enough room for cabling and to avoid interference to surrounding objects.

2.3 Pole Mount Mounting Kit PL/8094-1

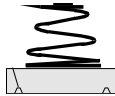
2.3.1 Pole Mount Mounting Kit

Kit KT/8094 includes:				
Qty.	Description		Qty.	Description
4	Unistrut — 14" long.  <i>Comtech EFData Part # FP/3595.</i>		8	5/16-18 x 1" bolt.  <i>Comtech EFData Part # HW/5/16-18X1BLT.</i>
6	1/4-20 x 5/8" bolt.  <i>Comtech EFData Part # 03P1131. Used to attach Unistruts to RFT.</i>		20	5/16" split washer.  <i>Comtech EFData Part # HW/5/16-SPLIT.</i>
6	1/4" flat washer.  <i>Comtech EFData Part # HW/1/4-FLT. Used to attach Unistruts to RFT.</i>		20	5/16" flat washer.  <i>Comtech EFData Part # HW/5/16-FLT.</i>
6	1/4" split washer.  <i>Comtech EFData Part # HW/1/4-SPLIT. Used to attach Unistruts to RFT.</i>		12	5/16-18 hex nut.  <i>Comtech EFData Part # HW/5/16-18HEXNT.</i>
8	Pipe block.  <i>Comtech EFData Part # HW/BLK-PIPE2-8. Used for round pole mount only.</i>		12	5/16-18 spring nut.  <i>Comtech EFData Part # HW/5/16-18SPNUT.</i>
4	Threaded rod, 5/16-18 x 14".  <i>Comtech EFData Part # HW/RD5/16-18X14.</i>		8	Flat fitting plate, 5/16".  <i>Comtech EFData Part # HW/FIT-PLT-5/16.</i>

2.3.2 BUC Round Pole Mounting Instructions

1. Position the BUC and mounting brackets facing upward. Position (2) 14" Unistrut channels centered on the converter mounting brackets. Fasten with 1/4" hardware (4 to 6 each of bolts, split and flat washers).

Note: Vary the number and location of the hardware as needed to avoid interfering with the spring nuts used for the pipe blocks.

2. Position two spring nuts into the channel of one of the remaining Unistrut channels. With the mounting holes facing the ends of the channel, fasten two pipe blocks loosely to the spring nuts with the hardware (2 each 5/16" bolts, split and flat washers).
3. Place the channel with pipe blocks against the mounting pole, slide the pipe blocks until they contact the mounting pole. Ensure the pipe blocks are centered to the Unistrut and tighten the hardware. Use this channel as a guide and mount the pipe blocks on the remaining three channels in a similar manner.
4. Position two spring nuts in each of the Unistrut channels mounted to the BUC. Position these nuts between the pipe blocks and the ends of the Unistrut.

Note: Above the spring nuts, position the flat fitting plates with the locating notches engaged in the openings of the channels.

5. Thread a 5/16" nut, split and flat washer onto each of the threaded rods, leaving 1" of rod remaining. Thread that end of the rod through the flat fitting plates and fully into the spring nuts (do not bottom out). Using one of the mating channels, ensure that the threaded rods from the channels mounted to the BUCs are aligned with holes in the mating channels. Center these rods with the channels as well as possible and tighten the hardware.
6. Thread a 5/16" nut, split, flat washer and flat fitting plate on the remaining ends of the threaded rods. This hardware is to secure the mating Unistrut channels from the opposite side of the pole to the threaded rod. Adjust accordingly.
7. Position the BUC with the pipe blocks against the pole, slide the mating Unistrut channels onto the threaded rods from the opposite side (pipe blocks against pole and channels against flat fitting plates). Adjust and fasten with the 5/16" hardware (4 each flat, split washers, and nuts).

2.3.3 Converter Square Pole Mounting Instructions

For square pole mount, follow the instructions in paragraph 2.1.3.2 but do not use the pipe blocks.

2.4 External Connectors

Connection	Function	Description	Mating Connector
J1	RF Input	N-Type, Female	N-Type, Male
J2	M&C Interface	ITT#KPT02E-12-105	ITT#KPT06E-12-105
J3	L-Band, DC, 10MHz Input	Type N Female	Type N Male
J4	Low Level RF Output	Type N Female	Type N Male
	AC-Line	CN/84913-0059	CA/84914-0223 (PWR Cord)



Note: When replacing fuses in the 25/32/40 Watt SSPA, use 6.3 amp, 3AG fuses, (2 each).

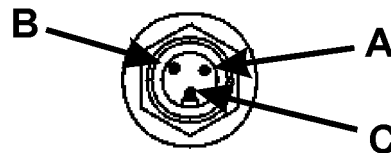

AC Line Input Connector (J3)

Pin	Function	Color
A	Line	Brown
B	Neutral	Blue
C	Ground	Green/Yellow

Chapter 3. Operation

3.1 Operation

The ODPa is a stand-alone terminal. The user can monitor and control some of the parameters, such as:

- RF Mute: On/Off => Turn the Ku-Band SSPA On/Off
- SSPA Fault Monitor

3.2 M&C Pinout Configuration

Pin #	Description	Remarks
G	-*_ Mute	Control / Monitor Pin: For control, pull pin to GND to mute, unit has an internal pull-up resistor. For Monitor, pin will be pulled to GND by the SSPA's M&C if a fault is present.
H	GND	
J	GND	
K	GND	

Note: Any pin not specified is factory use only.

3.3 Theory of Operation

The ODPA is required to have a 10 MHz reference signal, and a +15 to 24 VDC supply voltage from an L-Band Modem to the N-Type female connector (J3).

The ODPA will lock to the 10 MHz reference and then up convert an L-Band input signal to the Ku-Band output frequency. It outputs this low level signal on Ku-Band OUT (J4).

The Ku-Band output from L-Band to Ku-Band BUC will feed to the RF Input (J1). The SSPA will amplify the input Ku-Band signal from the BUC up to the desired output level.

Appendix A. EQUIPMENT OUTLINE DRAWINGS

A.1 Operation

This appendix describes the equipment outlines for the following components:

- 8 and 16 Watt ODPA (L-Band)
- 8 and 16 Watt ODPA (Non L-Band)
- 25 Watt ODPA (Non L-Band)
- 32/40 Watt ODPA (Non L-Band)
- 25- 40 Watt ODPA (L-Band)

Refer to the applicable section for more detailed information.

A.2 8 and 16Watt ODPA Equipment Outline (L-Band)

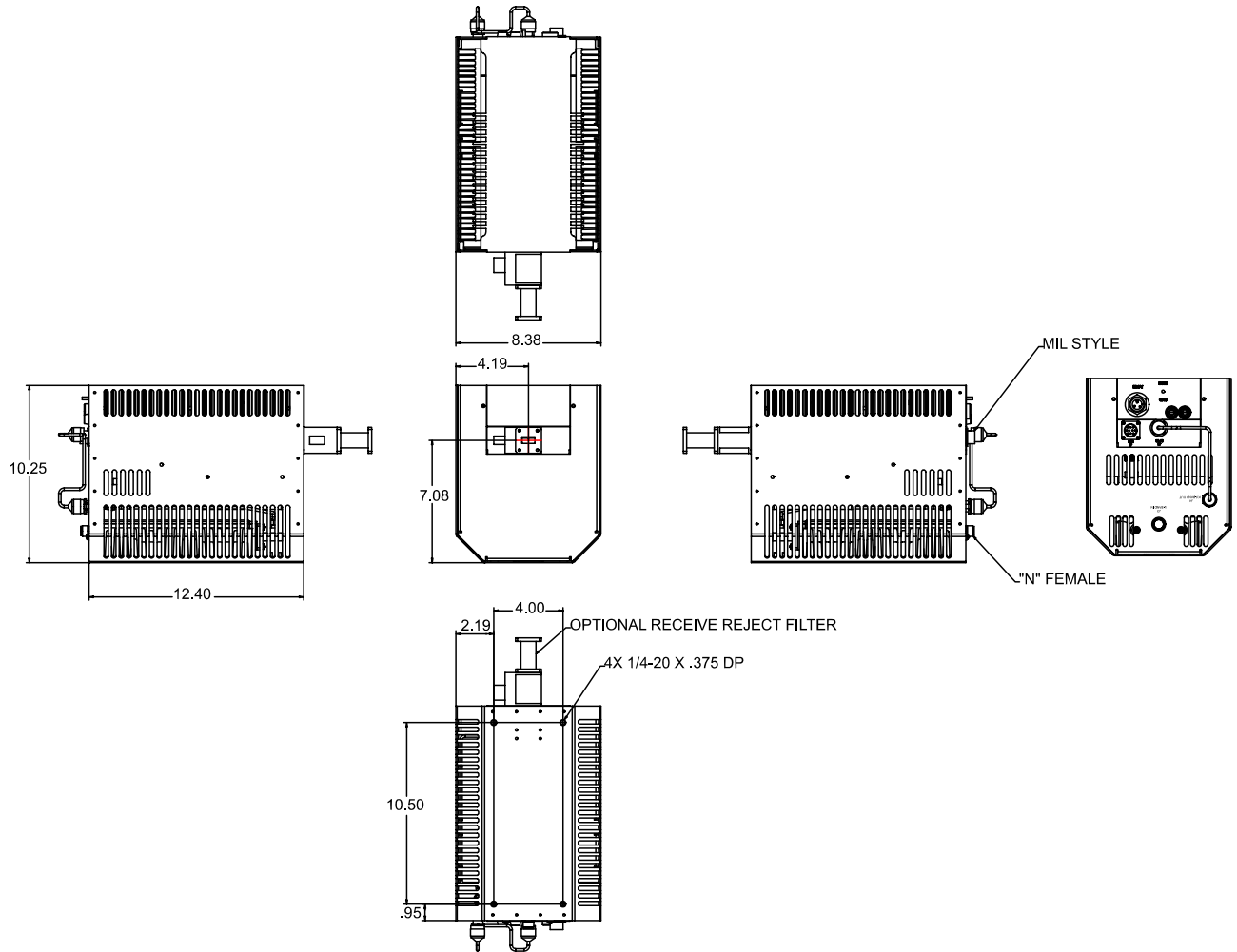

Figure A-1. 8 and 16 Watt ODPA Equipment Outline (L-Band)

A.3 8 and 16 Watt ODPa Equipment Outline (Non L-Band)

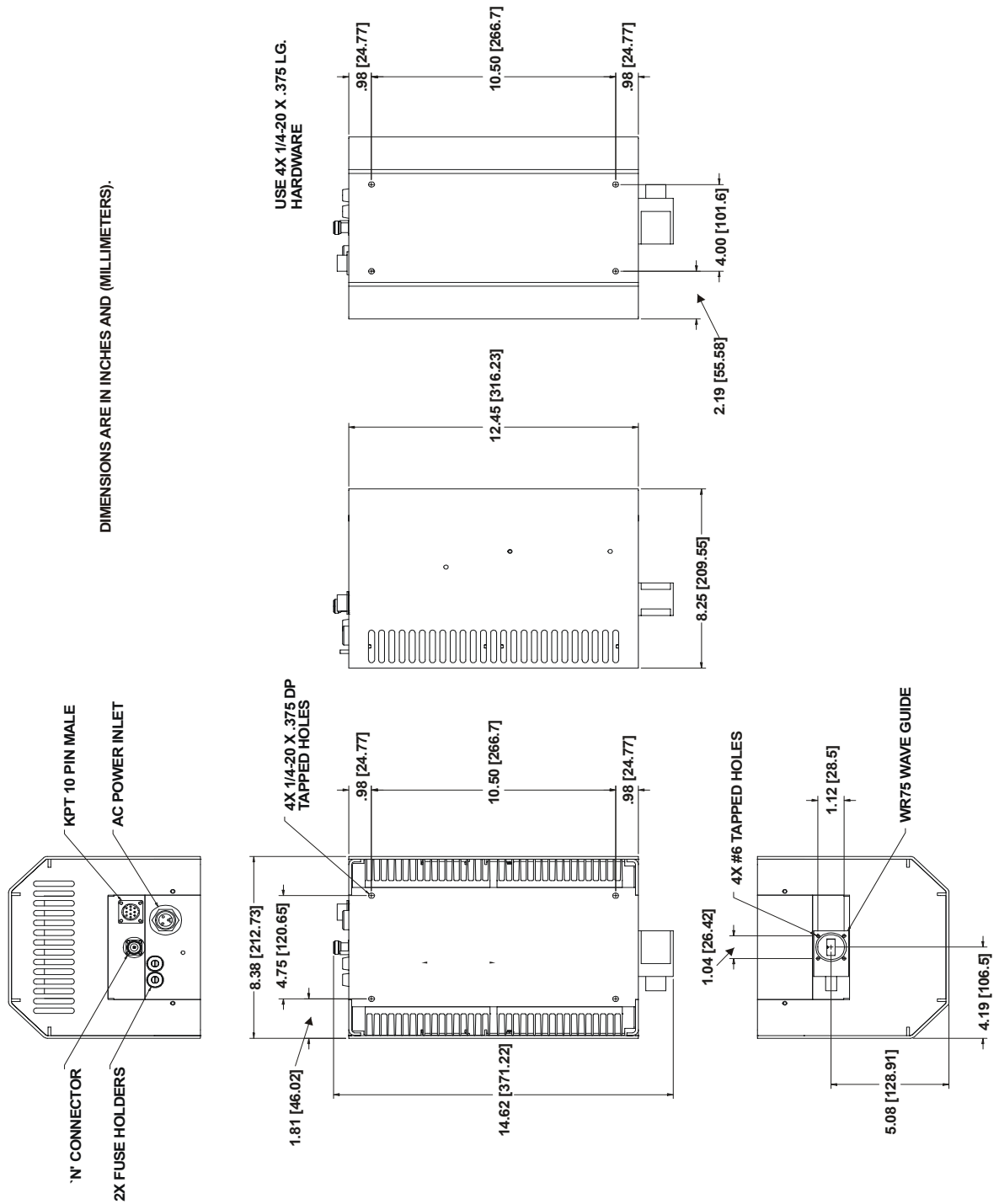

Figure A-2. 8 and 16Watt ODPa Equipment Outline (Non L-Band)

A.4 25 Watt ODPa Equipment Outline (Non L-Band)

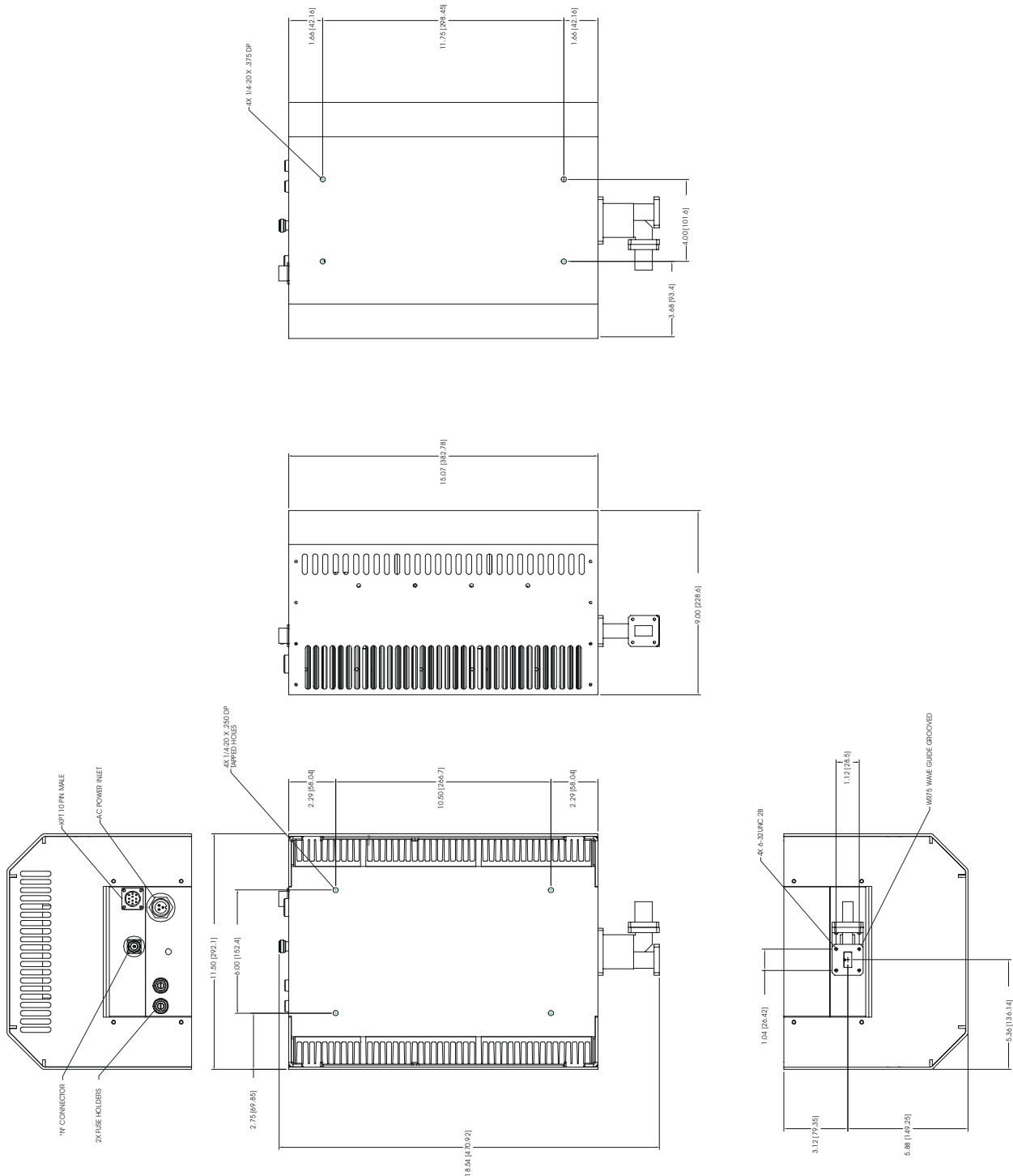

Figure A-3. 25Watt ODPa Equipment Outline (Non L-Band)

A.5 32/40 Watt ODPA Equipment Outline (Non L-Band)

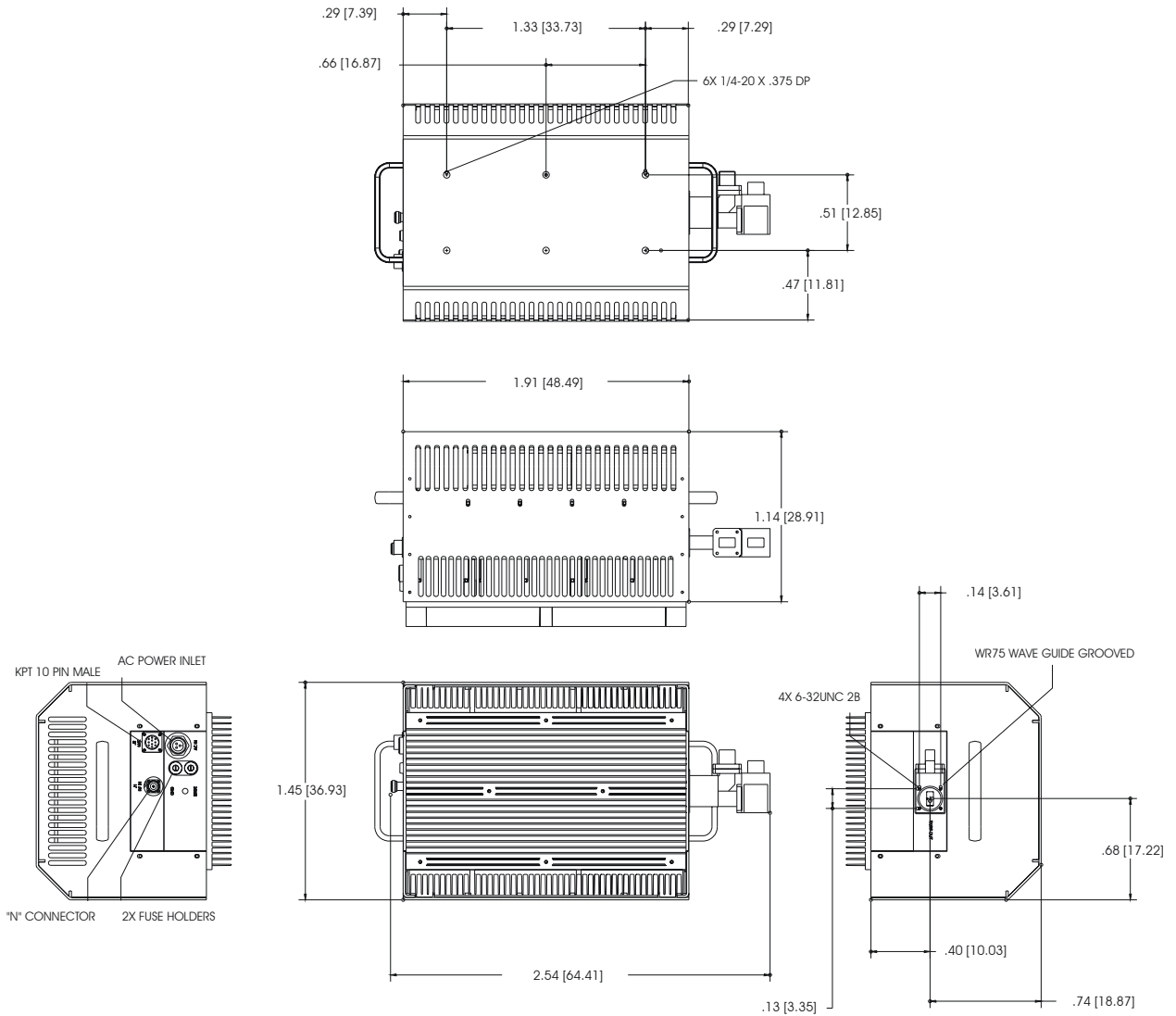
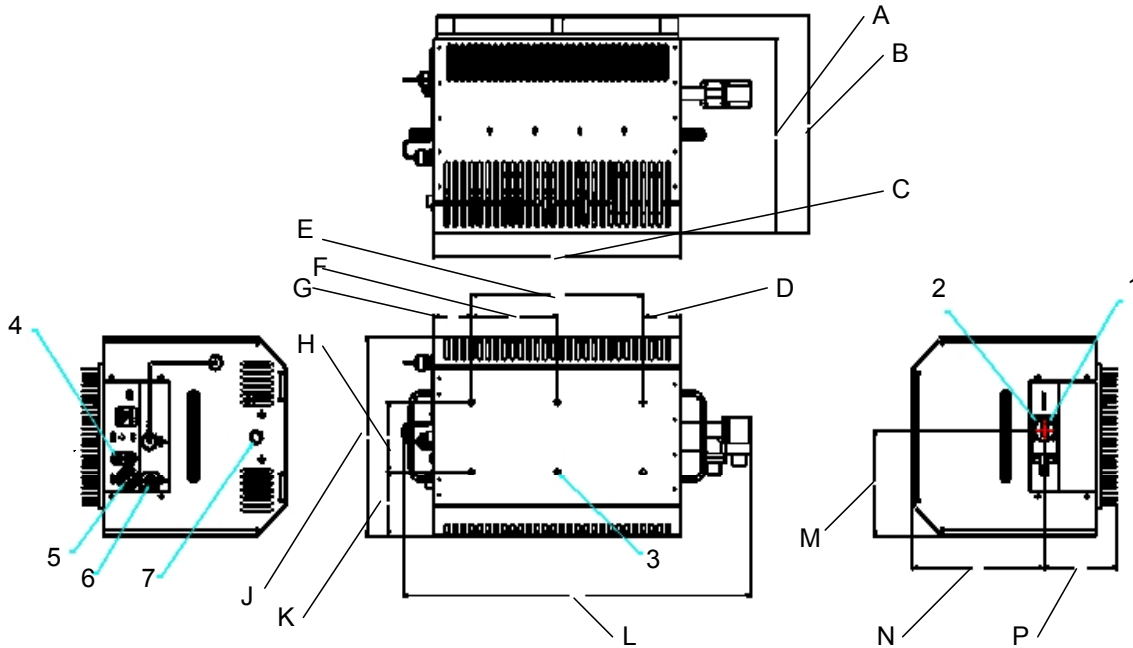

Figure A-4. 32/40 Watt ODPA Equipment Outline (Non L-Band)

A.6 25 through 40 Watt ODPa Equipment Outline (L-Band)



Designator	Remarks	Designator	Remarks	Designator	Remarks
A	11.20	K	3.75	1	WR75 Waveguide Grooved
B	12.51	L	21.25	2	4x 6-32 UNC 2B
C	15.10	M	6.15	3	6x 1/4-20 x .250 DP
D	2.30	N	8.07	4	2x Fuse Holders
E	10.50	P	4.44	5	AC IN
F	5.25			6	KPT 10 Pin Male
G	2.30			7	"N" RF IN
H	4.00				
J	1.50				

Note: All dimensions are in English units.

Figure A-5. 25-40 Watt ODPa Equipment Outline (L-Band)

METRIC CONVERSIONS

Units of Length

Unit	Centimeter	Inch	Foot	Yard	Mile	Meter	Kilometer	Millimeter
1 centimeter	—	0.3937	0.03281	0.01094	6.214×10^{-6}	0.01	—	—
1 inch	2.540	—	0.08333	0.2778	1.578×10^{-5}	0.254	—	25.4
1 foot	30.480	12.0	—	0.3333	1.893×10^{-4}	0.3048	—	—
1 yard	91.44	36.0	3.0	—	5.679×10^{-4}	0.9144	—	—
1 meter	100.0	39.37	3.281	1.094	6.214×10^{-4}	—	—	—
1 mile	1.609×10^5	6.336×10^4	5.280×10^3	1.760×10^3	—	1.609×10^3	1.609	—
1 mm	—	0.03937	—	—	—	—	—	—
1 kilometer	—	—	—	—	0.621	—	—	—

Temperature Conversions

Unit	° Fahrenheit	° Centigrade
32° Fahrenheit	—	0 (water freezes)
212° Fahrenheit	—	100 (water boils)
-459.6° Fahrenheit	—	273.1 (absolute 0)

Formulas
$C = (F - 32) * 0.555$
$F = (C * 1.8) + 32$

Units of Weight

Unit	Gram	Ounce Avoirdupois	Ounce Troy	Pound Avoir.	Pound Troy	Kilogram
1 gram	—	0.03527	0.03215	0.002205	0.002679	0.001
1 oz. avoir.	28.35	—	0.9115	0.0625	0.07595	0.02835
1 oz. troy	31.10	1.097	—	0.06857	0.08333	0.03110
1 lb. avoir.	453.6	16.0	14.58	—	1.215	0.4536
1 lb. Troy	373.2	13.17	12.0	0.8229	—	0.3732
1 kilogram	1.0×10^3	35.27	32.15	2.205	2.679	—



2114 WEST 7TH STREET TEMPE ARIZONA 85281 USA
480 • 333 • 2200 PHONE
480 • 333 • 2161 FAX