



# *CRS-300*

---

## **1:10 Redundancy Switch Installation and Operation Manual**

**IMPORTANT NOTE:** The information contained in this document supersedes all previously published information regarding this product. Product specifications are subject to change without prior notice.





# *CRS-300*

---

## **1:10 Redundancy Switch Installation and Operation Manual**

Part Number MN/CRS300.IOM  
Revision 19



# TABLE OF CONTENTS

<b>TABLE OF CONTENTS</b> .....	<b>III</b>
<b>TABLES</b> .....	<b>XI</b>
<b>FIGURES</b> .....	<b>XII</b>
<b>PREFACE</b> .....	<b>XVII</b>
<b>About this Manual</b> .....	<b>xvii</b>
Related Documents .....	xvii
<b>Conventions and References</b> .....	<b>xviii</b>
Patents and Trademarks.....	xviii
Warnings, Cautions and Notes .....	xviii
Examples of Multi-Hazard Notices .....	xviii
Recommended Standard Designations .....	xix
<b>Safety and Compliance</b> .....	<b>xix</b>
Electrical Safety and Compliance.....	xix
Electrical Installation .....	xix
Operating Environment .....	xix
European Union Radio Equipment and Telecommunications Terminal Equipment (R&TTE) Directive (1999/5/EC) and EN 301 489-1 .....	xx
European Union Electromagnetic Compatibility (EMC) Directive (2004/108/EC) .....	xx
European Union Low Voltage Directive (LVD) (2006/95/EC) .....	xxi
European Union RoHS Directive (2002/95/EC) .....	xxi
European Union Telecommunications Terminal Equipment Directive (91/263/EEC) .....	xxi
CE Mark .....	xxi
<b>Product Support</b> .....	<b>xxi</b>
<b>Comtech EF Data Headquarters</b> .....	<b>xxii</b>
<b>Warranty Policy</b> .....	<b>xxii</b>
Limitations of Warranty.....	xxii
Exclusive Remedies.....	xxiii
<b>CHAPTER 1.    INTRODUCTION</b> .....	<b>1-1</b>
<b>1.1    Overview</b> .....	<b>1-1</b>
1.1.1    System-Level Block Diagram.....	1-4

1.1.2	CRS-280/280L Functional Schematic .....	1-5
<b>1.2</b>	<b>CRS-300 Compatibility.....</b>	<b>1-6</b>
<b>1.3</b>	<b>Description of CRS-300 Features.....</b>	<b>1-7</b>
1.3.1	Front Panel .....	1-7
1.3.2	Rear Panel.....	1-8
1.3.3	Plug-in Module (Card) Assemblies.....	1-9
1.3.3.1	CRS-300 System Controller Card Assembly .....	1-9
1.3.3.2	Power Supply Card Assemblies .....	1-9
1.3.3.3	Modem Interface Cards .....	1-10
1.3.3.3.1	CDM-625/A, CDM-570/A, CDM-570L/AL, CDM-600/L Interface Cards .....	1-10
1.3.3.3.1.1	RMI Card .....	1-11
1.3.3.3.1.2	TMI Cards.....	1-11
1.3.3.3.2	SLM-5650/5650A, CDM-Qx/QxL, CDM-710G/710GL, CDM-710, CDM-700 Interface Cards .....	1-12
1.3.3.3.2.1	RMI Cards.....	1-13
1.3.3.3.2.2	TMI Cards.....	1-14
<b>1.4</b>	<b>Optional CRS-350 ESC Switch.....</b>	<b>1-15</b>
<b>1.5</b>	<b>Summary of Specifications .....</b>	<b>1-17</b>
1.5.1	CRS-300 1:10 Redundancy Switch Specifications .....	1-17
1.5.2	Modem vs. Terrestrial User Data Interface Specifications .....	1-18
1.5.3	CRS-280 and CRS-280L IF Switch Specifications .....	1-19
1.5.4	CRS-350 ESC Switch Specifications .....	1-19
1.5.5	Dimensional Envelope Details .....	1-20
<b>CHAPTER 2.</b>	<b>INSTALLATION .....</b>	<b>2-1</b>
<b>2.1</b>	<b>Unpack and Inspect the Shipment .....</b>	<b>2-1</b>
<b>2.2</b>	<b>Install the Unit Into a Rack Enclosure.....</b>	<b>2-2</b>
<b>CHAPTER 3.</b>	<b>SWITCH CONNECTORS AND PINOUTS .....</b>	<b>3-1</b>
<b>3.1</b>	<b>Cabling Connection Types .....</b>	<b>3-1</b>
3.1.1	Coaxial Cable Connections.....	3-1
3.1.1.1	Type 'BNC' .....	3-2
3.1.1.2	Type 'TNC' .....	3-2
3.1.1.3	Type 'N' .....	3-2
3.1.1.4	Type 'F' .....	3-2
3.1.1.5	Type 'SMA' (Subminiature Version 'A').....	3-3
3.1.2	D-Subminiature Cable Connections.....	3-3
3.1.3	RJ-45, RJ-48 Cable Connections.....	3-3
<b>3.2</b>	<b>CRS-300 User Data Connectors .....</b>	<b>3-4</b>
3.2.1	CRS-230 Controller Connectors .....	3-4

3.2.1.1	IF Switch Control Connector, DB-25M .....	3-4
3.2.1.2	485 Pass-Through Connector, DB-9F .....	3-4
3.2.1.3	Remote Control Connector, DB-9M .....	3-5
3.2.1.4	System Alarms Connector, DB-25F .....	3-6
3.2.2	TMI User Data Connectors .....	3-7
3.2.2.1	EIA-232/422/V.35 Connector, DB-25F (CRS-316) .....	3-7
3.2.2.2	EIA-232/422/V.35/LVDS Connector, DB-25F (CRS-320/340) .....	3-8
3.2.2.3	ASI Connectors, BNC (CRS-325) .....	3-9
3.2.2.4	8 kHz IDR Connector, RJ-45F (CRS-330) .....	3-9
3.2.2.5	Balanced G.703 Connector, DB-15F (CRS-325/330/340) .....	3-10
3.2.2.6	Unbalanced G.703 Connectors, BNC (CRS-325/330/340) .....	3-11
3.2.2.7	Unbalanced G.703 4-Port Connectors, BNC (CRS-345) .....	3-11
3.2.2.8	HSSI Connector, HD-50F (CRS-336/370) .....	3-12
3.2.2.9	10/100/1000 Gigabit Ethernet Connector, RJ-45F (CRS-316/336) .....	3-13
3.2.2.10	Quad E1 Connectors, RJ-48F (CRS-365) .....	3-14
3.2.2.11	Quad E1 Connectors, DB-9F (CRS-365D) .....	3-15
<b>3.3</b>	<b>CRS-300 Chassis Ground and Power Connections .....</b>	<b>3-16</b>
3.3.2.2	48V Direct Current (DC) Power Interface .....	3-19
<b>CHAPTER 4.</b>	<b>CABLES AND CONNECTIONS .....</b>	<b>4-1</b>
<b>4.1</b>	<b>Overview .....</b>	<b>4-1</b>
<b>4.2</b>	<b>Switch-to-Switch Connections .....</b>	<b>4-4</b>
4.2.1	CRS-300 to CRS-280/280L Connection .....	4-4
4.2.2	CRS-300 to CRS-350 Connection .....	4-4
4.2.3	CRS-300 to CRS-350 and CRS-280/280L Connection .....	4-4
<b>4.3</b>	<b>IF Cable Connections .....</b>	<b>4-12</b>
4.3.1	IF Cable Connections – Single Transponder (without CRS-280/280L) .....	4-12
4.3.2	IF Cable Connections – Multiple Transponder (Using IF Switch) .....	4-14
<b>4.4</b>	<b>CDM-625/A Modem Connections .....</b>	<b>4-18</b>
4.4.1	RMI/TMI Limitations and Considerations .....	4-18
4.4.2	Carrier-in-Carrier® (CnC) Data Connections .....	4-19
4.4.3	Control and Data Connections – CRS-300 to Modem .....	4-21
4.4.3.1	Control Cabling Requirement (Regardless of Driving Traffic Data Type) .....	4-21
4.4.3.2	G.703 Balanced / Unbalanced Data Connections .....	4-22
4.4.3.3	G.703 Quad E1 Data Connections .....	4-23
4.4.3.4	ASI Data Connections .....	4-24
4.4.3.5	EIA-422 Data Connections .....	4-25
4.4.3.6	HSSI Data Connections .....	4-26
4.4.3.7	LVDS Data Connections .....	4-26
4.4.3.8	Ethernet Data Connections .....	4-26
4.4.3.8.1	Ethernet Data Connection – Wired-thru Method (No Sub-Mux) .....	4-27
4.4.3.8.2	Ethernet Data Connection – Wired-around Method (Sub-Mux) .....	4-28
4.4.4	Data Connections – CRS-300 to User .....	4-33

4.4.5	Data Connections – CRS-350 Engineering Service Channel (ESC) Switch.....	4–33
4.4.5.1	ESC Data Connections – Modems to CRS-350 .....	4–33
4.4.5.2	ESC Data Connections – CRS-350 to User .....	4–33
4.4.6	Operation of the CDM-625/A in CDM-600/L Emulation Mode .....	4–33
4.4.6.1	Preparing the CDM-625/A for Operation in CDM-600/L Emulation Mode .....	4–34
4.4.6.2	Control and Data Connections – CRS-300 to Modems in CDM-600/L Emulation Mode.....	4–34
	.....	4–34
<b>4.5</b>	<b>CDM-570/A, CDM-570L/AL Modem Connections .....</b>	<b>4–38</b>
4.5.1	Control and Data Connections – CRS-300 to Modems.....	4–38
4.5.2	User Data Connections – CRS-300 to User .....	4–38
<b>4.6</b>	<b>SLM-5650/5650A Modem Connections.....</b>	<b>4–42</b>
4.6.1	RMI/TMI Limitations and Considerations.....	4–42
4.6.2	Control Cable Connections – CRS-300 to Modems .....	4–42
4.6.3	Traffic Data Connections – CRS-300 to Modems.....	4–43
4.6.3.1	Ethernet Traffic Data Connections.....	4–44
4.6.3.1.1	Ethernet Bridge Mode via the Optional GbE Interface.....	4–44
4.6.3.1.2	Ethernet Bridge Mode via the Optional NP Interface.....	4–44
4.6.4	User Data Connections – CRS-300 to User .....	4–44
4.6.5	ESC Data Connections – Modems to CRS-350.....	4–44
4.6.6	User ESC Data Connections – CRS-350 to User .....	4–45
<b>4.7</b>	<b>CDM-Qx/QxL Modem Connections .....</b>	<b>4–52</b>
4.7.1	RMI/TMI Limitations and Considerations.....	4–52
4.7.2	EIA-485 Connections – CRS-300 to Modems.....	4–52
4.7.3	Control Y-Cable Connections – CRS-300 to Modems .....	4–54
4.7.4	Traffic Data Connections – CRS-300 to Modems.....	4–54
4.7.5	User Data Connections – CRS-300 to User .....	4–55
<b>4.8</b>	<b>CDM-710G/710GL Modem Connections.....</b>	<b>4–62</b>
4.8.1	RMI/TMI Limitations and Considerations.....	4–62
4.8.2	Interface Combinations .....	4–62
4.8.3	Control Cable Connections – CRS-300 to Modems .....	4–63
4.8.4	Serial Traffic Data Connections – CRS-300 to Modems.....	4–63
4.8.5	Ethernet Traffic Data Connections – CRS-300 to Modems .....	4–63
4.8.6	User Data Connections – CRS-300 to User .....	4–64
<b>4.9</b>	<b>CDM-710 Modem Connections .....</b>	<b>4–68</b>
4.9.1	RMI/TMI Limitations and Considerations.....	4–68
4.9.2	Interface Combinations .....	4–68
4.9.3	Control Cable Connections – CRS-300 to Modems .....	4–69
4.9.4	Serial Traffic Data Connections – CRS-300 to Modems.....	4–69
4.9.5	Ethernet Traffic Data Connections – CRS-300 to Modems .....	4–69
4.9.6	User Data Connections – CRS-300 to User .....	4–70
<b>4.10</b>	<b>CDM-700 Modem Connections .....</b>	<b>4–74</b>
4.10.1	RMI/TMI Limitations and Considerations .....	4–74



4.10.2	Interface Combinations.....	4-74
4.10.3	Control Cable Connections – CRS-300 to Modems.....	4-75
4.10.4	Serial Traffic Data Connections – CRS-300 to Modems.....	4-75
4.10.5	Ethernet Traffic Data Connections – CRS-300 to Modems.....	4-76
4.10.5.1	Wired-thru Connections.....	4-76
4.10.5.2	Wired-around Connections.....	4-76
4.10.6	User Data Connections – CRS-300 to User.....	4-77
<b>4.11</b>	<b>CDM-600/L Modem Connections.....</b>	<b>4-86</b>
4.11.1	Control and Data Connections – CRS-300 to Modems.....	4-86
4.11.2	User Data Connections – CRS-300 to User.....	4-88
4.11.3	ESC Data Connections – Modems to CRS-350.....	4-88
4.11.4	User ESC Data Connections – CRS-350 to User.....	4-88
<b>CHAPTER 5.</b>	<b>MODEM, RMI/TMI, AND SWITCH CONFIGURATION.....</b>	<b>5-1</b>
<b>5.2</b>	<b>Configure Your Modems.....</b>	<b>5-2</b>
5.2.1	Connect Your Modem Power.....	5-2
5.2.2	Modem Firmware and Hardware Requirements.....	5-2
5.2.2.1	Update Your Modem Firmware.....	5-3
5.2.3	Configure Your Modem Operation.....	5-3
5.2.4	Configure Your Modems for 1:N Redundancy.....	5-3
5.2.4.1	Configure Switch-to-CDM-625/A 1:N Redundancy.....	5-3
5.2.4.1.1	Configure CDM-625/A 1:N Redundancy for Carrier-in-Carrier®.....	5-4
5.2.4.2	Configure Switch-to-CDM-570/A, CDM-570L/AL, CDM-600/L 1:N Redundancy.....	5-5
5.2.4.3	Configure Switch-to-SLM-5650/5650A 1:N Redundancy.....	5-5
5.2.4.4	Configure Switch-to-CDM-Qx/QxL 1:N Redundancy.....	5-7
5.2.4.5	Configure Switch-to-CDM-710G/710GL, CDM-710, CDM-700 1:N Redundancy.....	5-10
<b>5.3</b>	<b>RMI Card Configuration Reference.....</b>	<b>5-11</b>
<b>5.4</b>	<b>TMI Card Configuration Reference.....</b>	<b>5-12</b>
5.4.1	EIA-530 Interfaces via the CRS-316 TMI.....	5-12
5.4.2	EIA-232/-422, V.35 Interfaces via the CRS-320 and CRS-340 TMIs.....	5-15
5.4.3	HSSI Interfaces via the CRS-336 TMI.....	5-17
5.4.4	HSSI Interface via the CRS-370 TMI.....	5-19
<b>5.5</b>	<b>Configure the CRS-300 Switch.....</b>	<b>5-20</b>
5.5.1	Connect the Switch Power.....	5-20
5.5.2	About the Switch Fuses.....	5-20
<b>5.6</b>	<b>Update the CRS-300 Switch Firmware.....</b>	<b>5-21</b>
5.6.1.1	About Firmware Files, Naming, Versions, and Archive Formats.....	5-21
5.6.1.2	Switch Firmware Update Procedure.....	5-22
5.6.1.2.1	Getting Started: Prepare for the Firmware Download.....	5-22
5.6.1.2.2	Download and Extract the Firmware Update.....	5-23
5.6.1.2.3	Execute the CCCFLASH Upload Utility Application.....	5-25
5.6.2	Configure the CRS-300 Switch Operation.....	5-25

- 5.6.2.1 Activate the Traffic Modems ..... 5-25
- 5.6.2.2 Verify Each Active Modem Connection ..... 5-26
- 5.6.2.3 Set the Switch Operation Mode ..... 5-27
- 5.6.2.4 Set the Holdoff Period ..... 5-27
- 5.6.2.5 Set the Backup Holdoff Period..... 5-28
  - 5.6.2.5.1 Set the Restore Holdoff Period ..... 5-28
- 5.6.2.6 Set the Alarm Masks ..... 5-29
  
- CHAPTER 6. FRONT PANEL OPERATION ..... 6-1**
  
- 6.1 Overview ..... 6-1**
- 6.1.1 Front Panel LED Indicators ..... 6-2
  - 6.1.1.1 Switch Status LED Indicators..... 6-2
  - 6.1.1.2 Modem Status LED Indicators..... 6-3
- 6.1.2 Front Panel Keypad..... 6-4
- 6.1.3 Front Panel Vacuum Fluorescent Display (VFD) ..... 6-5
  - 6.1.3.1 Opening Screen..... 6-5
  - 6.1.3.2 Menu Structure..... 6-6
  
- 6.2 Front Panel Operation..... 6-7**
- 6.2.1 SELECT: (Top-Level) Menu ..... 6-7
- 6.2.2 SELECT: CONFIG (Configuration) ..... 6-7
  - 6.2.2.1 CONFIG: MANUAL..... 6-8
  - 6.2.2.2 CONFIG: AUTO (AUTO-OFF or AUTO-ON)..... 6-8
  - 6.2.2.3 CONFIG: OPTIONS..... 6-9
    - 6.2.2.3.1 CONFIG: OPTIONS → PRIORITY ..... 6-9
    - 6.2.2.3.2 CONFIG: OPTIONS → HOLDOFFS ..... 6-9
    - 6.2.2.3.3 CONFIG: OPTIONS → ALARM-MASK..... 6-10
  - 6.2.2.4 CONFIG: REMOTE..... 6-11
    - 6.2.2.4.1 CONFIG: REMOTE → LOCAL..... 6-11
    - 6.2.2.4.2 CONFIG: REMOTE → REMOTE ..... 6-11
  - 6.2.2.5 CONFIG: ACTIVE (Activate Modems) ..... 6-12
- 6.2.3 SELECT: INFO (Information)..... 6-14
  - 6.2.3.1 INFO: S/N ..... 6-14
  - 6.2.3.2 INFO: ID..... 6-14
  - 6.2.3.3 INFO: SETUP ..... 6-14
  - 6.2.3.4 INFO: IF-SWITCH ..... 6-14
  - 6.2.3.5 INFO: REMCONT (Remote Control Info) ..... 6-15
  - 6.2.3.6 INFO: MASK (Alarm Mask Info)..... 6-15
- 6.2.4 SELECT: MONITOR ..... 6-15
  - 6.2.4.1 MONITOR: STATUS..... 6-15
  - 6.2.4.2 MONITOR: SW-ALARM..... 6-16
  - 6.2.4.3 MONITOR: STORED-EVENTS ..... 6-19
    - 6.2.4.3.1 MONITOR: STORED-EVENTS → VIEW ..... 6-19
    - 6.2.4.3.2 MONITOR: STORED-EVENTS → CLEAR-ALL..... 6-19
  - 6.2.4.4 MONITOR: COMMS (Communications State)..... 6-19
  - 6.2.4.5 MONITOR: IO ..... 6-20
- 6.2.5 SELECT: STORE/LD (Store or Load Configuration) ..... 6-20

6.2.5.1	STORE/LD: STORE.....	6-20
6.2.5.2	STORE/LD: LOAD .....	6-21
6.2.6	SELECT: UTILITY.....	6-21
6.2.6.1	UTILITY: SET- RTC (Set Real-Time Clock) .....	6-21
6.2.6.2	UTILITY: DISPLAY (Display Brightness) .....	6-21
6.2.6.3	UTILITY: SWITCH-ID.....	6-22
6.2.6.4	UTILITY: TEST.....	6-22
6.2.6.5	UTILITY: RELAY .....	6-22
<b>CHAPTER 7.</b>	<b>SERIAL-BASED REMOTE PRODUCT MANAGEMENT .....</b>	<b>7-1</b>
<b>7.1</b>	<b>Overview .....</b>	<b>7-1</b>
<b>7.2</b>	<b>EIA-485.....</b>	<b>7-1</b>
<b>7.3</b>	<b>EIA-232.....</b>	<b>7-2</b>
<b>7.4</b>	<b>Rules for Remote Serial Communications with the CRS-300.....</b>	<b>7-2</b>
<b>7.5</b>	<b>Basic Protocol .....</b>	<b>7-3</b>
7.5.1	Packet Structure .....	7-4
7.5.1.1	Start of Packet.....	7-4
7.5.1.2	Target Address .....	7-5
7.5.1.3	Address Delimiter .....	7-6
7.5.1.4	Instruction Code.....	7-6
7.5.1.5	Instruction Code Qualifier.....	7-6
7.5.1.6	Optional Message Arguments .....	7-7
7.5.1.7	End Of Packet.....	7-7
<b>7.6</b>	<b>Remote Commands and Queries .....</b>	<b>7-8</b>
<b>APPENDIX A.</b>	<b>ETHERNET NETWORK CONFIGURATIONS .....</b>	<b>A-1</b>
<b>A.1</b>	<b>Overview .....</b>	<b>A-1</b>
<b>A.2</b>	<b>Ethernet Routers vs. Switches .....</b>	<b>A-1</b>
<b>A.3</b>	<b>Ethernet Configuration Examples .....</b>	<b>A-2</b>
A.3.1	Ethernet Network Overview.....	A-2
A.3.2	Ethernet Redundancy with CRS-300.....	A-3
A.3.2.1	Wired-thru Connection.....	A-3
A.3.2.2	Wired-around Connection .....	A-3
A.3.4	Hub-to-Hub with Standard Traffic using Routers.....	A-4
A.3.5	Hub-to-Hub with Standard Traffic using Switches .....	A-6
A.3.6	Hub-to-Remotes with Standard Traffic using Routers or Switches.....	A-8
A.3.7	Hub-to-Remotes, Split-path Traffic using Routers (Point-to-Multipoint).....	A-10
A.3.8	Hub-to-Remotes, Split-path Traffic using Switches (Point-to-Multipoint).....	A-12

<b>APPENDIX B. CABLE DRAWINGS.....</b>	<b>B-1</b>
<b>B.1 Overview .....</b>	<b>B-1</b>
<b>B.2 User / Utility Cables .....</b>	<b>B-1</b>
B.2.1 Switch-to-User, EIA-530-to-EIA-422/-449 Data Conversion Cable (DB-25M→DB-37F).....	B-2
B.2.2 Switch-to-User, EIA-530-to-V.35 Data Conversion Cable (DB-25M→Winchester 34F) .....	B-3
B.2.3 Switch-to-User, Monitor and Control (M&C) Cable (DB-9F→DB-9F).....	B-4
<b>B.3 Control Cables .....</b>	<b>B-5</b>
B.3.1 Switch-to-Modem, Control Cable for CDM-625/A (HD-15M→DB-9M) .....	B-6
B.3.2 Switch-to-Modem, Control Cable for SLM-5650/5650A (HD-15M→HD-15M).....	B-7
B.3.3 Switch-to-Modem, Optional ‘Y’ Control Cable for SLM-5650/5650A (HD-15M→HD-15M, DB-9F) .....	B-8
B.3.4 Switch-to-Modem, Standard EIA-485 Multi-Drop Shielded Cable for CDM-Qx/QxL (15X DB-9F) .....	B-9
B.3.5 EIA-485 Cable Termination for CDM-Qx/QxL Multi-Drop Cables (DB-9M) .....	B-10
B.3.6 Switch-to-Modem, EIA-485 Null Modem Cable for CDM-Qx/QxL (DB-9M→DB-9M).....	B-11
B.3.7 Modem-to-Modem, Optional EIA-485 Multi-Drop Ribbon Cable for CDM-Qx/QxL (15X DB-9F) . .....	B-12
B.3.8 Switch-to-Modem, ‘Y’ Control Cable for CDM-Qx/QxL with CnC <sup>®</sup> (HD-15M→2X DB-15F)...	B-13
B.3.9 Switch-to-Modem, Control Cable for CDM-7XX (HD-15M→DB-15F) .....	B-14
<b>B.4 Control / IF / Data Cables &amp; Accessories .....</b>	<b>B-15</b>
B.4.1 Switch-to-Modem / Switch-to-User, EIA-232/422, EIA-530 Control and Data Cable (DB-25M→DB-25F).....	B-18
B.4.2 Switch-to-Modem / Modem-to-User, IF Cable (BNC 50Ω Male).....	B-19
B.4.3 Switch-to-Modem, ASI / Balanced G.703 / IF Cable (BNC 75Ω Male).....	B-20
B.4.4 Modem-to-Modem, Multi-Drop CnC <sup>®</sup> Plus Shielded Data Cable for CDM-625/A (11X DB-9M) ... .....	B-21
B.4.5 Modem-to-User, Ethernet Data Cable for CDM-625/A (RJ-45M→HD-50M).....	B-22
B.4.6 Switch-to-Modem, Balanced G.703 Data Cable for CDM-625/A (DB-15F→DB-15M) .....	B-23
B.4.7 Switch-to-Modem / Modem-to-User, Gigabit Ethernet, Quad E1 RJ-48 Connector Cable (RJ-48M→RJ-48M).....	B-24
B.4.8 Switch-to-Modem, HSSI Data Cable (HD-50M→HD-50M).....	B-25
B.4.9 Switch-to-Modem, Quad E1 Data ‘Y’ Cable for CDM-625/A (DB-15F→2X DB-9M) .....	B-26
B.4.10 Modem-to-User, Quad E1 Data Cable for CDM-625/A (DB-9M→DB-9F).....	B-27
B.4.11 Modem-to-User, Quad E1 Data Adapter Cable for CDM-625/A (DB-9M→2X DB-15F)....	B-28
B.4.12 Modem-to-User, Quad E1 Data Adapter Cable for CDM-625/A (DB-9M→2X RJ-48F) .....	B-29
B.4.13 Modem-to-Switch (CDM-625/A to CRS-350), Overhead Data Cable (DB-44M, DB-9M→DB-9F, DB-25M, DB-15F) .....	B-30
B.4.14 Switch-to-User / Switch-to-Modem, Balanced G.703 Data Cable (DB-15M→DB-15F) ....	B-31
B.4.15 Switch-to-Modem / Switch-to-User, Balanced G.703 Data Cable for CDM-570/A, CDM-570L/AL (DB-15M→DB-15F) .....	B-32
B.4.16 Modem-to-User, Optional T1/E1 Adapter for CDM-570/A, CDM-570L/AL, CDM-600/L (DB-15M→RJ-48F).....	B-33
B.4.17 Switch-to-Modem, Quad E1 Data Cable for CDM-Qx/QxL (DB-15F→4X RJ-45M).....	B-34
B.4.18 Switch-to-Modem, G.703 Data Cable for CDM-700 (DB-9F→8X BNC 75Ω Male) .....	B-35

B.4.19 Switch-to-Modem, G.703 Data Cable for CDM-700 (DB-15F→8X BNC 75Ω Male) ..... B-36  
 B.4.20 Switch-to-Modem, Audio Data Cable for CDM-600/L (DB-9M→DB-9F) ..... B-37

**APPENDIX C. ADDRESSING SCHEME INFORMATION .....C-1**

**C.1 Addressing Overview .....C-1**  
 C.1.1 Switch Addresses ..... C-2  
 C.1.2 Modem and Transceiver Addresses ..... C-2

**C.2 Modem Setup .....C-11**

**C.3 Transceiver Setup ..... C-12**

**C.4 M&C Applications .....C-13**

## TABLES

Table 1-1. CRS-300 Compatibility Table ..... 1-6  
 Table 3-1. 485 Pass-Through User Data Connector ..... 3-4  
 Table 3-2. Remote Control Connector ..... 3-5  
 Table 3-3. System Alarms Connector ..... 3-6  
 Table 3-4. EIA-232/422/V.35 Connector ..... 3-7  
 Table 3-5. EIA-232/422/V.35/LVDS Connector ..... 3-8  
 Table 3-6. ASI Connectors ..... 3-9  
 Table 3-7. 8 kHz – IDR ESC Connector ..... 3-9  
 Table 3-8. Balanced G.703 Connector ..... 3-10  
 Table 3-9. Unbalanced G.703 Connectors ..... 3-11  
 Table 3-10. Unbalanced G.703 Connectors ..... 3-11  
 Table 3-11. HSSI Connector ..... 3-12  
 Table 3-12. 10/100/1000 Gigabit Ethernet Connector Pinouts ..... 3-13  
 Table 3-13. Quad E1 Connector Pinouts (Typical Ports 1 through 4) ..... 3-14  
 Table 3-14. Quad E1 Connector Pair Pinouts ..... 3-15  
 Table 4-1. CDM-625/A Cable Usage (RMI/TMI) ..... 4-21  
 Table 4-2. CDM-710G/710GL Interface Card Combinations ..... 4-62  
 Table 4-3. CDM-710 Interface Card Combinations ..... 4-68  
 Table 4-4. CDM-700 Interface Card Combinations ..... 4-74  
 Table 5-1. RMI “JMP1” Jumper Settings (As Shipped) ..... 5-11  
 Table 5-2. CRS-316 “JP1” Jumper Settings ..... 5-13  
 Table 5-3. CRS-316 “JP2” Jumper Settings ..... 5-14  
 Table 5-4. CRS-316 “JP3” through “JP6” Jumper Settings ..... 5-14  
 Table 5-5. CRS-320/CRS-340 Jumper Settings ..... 5-16  
 Table 5-6. CRS-336 Jumper “JP1” Settings ..... 5-18  
 Table 5-7. CRS-336 Jumper “JP2” Settings ..... 5-18  
 Table 5-8. CRS-370 Jumper “J2” Settings ..... 5-19

## FIGURES

Figure 1-1. Typical Redundancy System-Level Block Diagram.....	1-4
Figure 1-2. CRS-280/280L IF Switch Functional Schematic.....	1-5
Figure 1-3. CRS-300 Front Panel Features .....	1-7
Figure 1-4. CRS-300 Rear Panel – Configuration Example .....	1-8
Figure 1-5. CRS-230 System Controller (AS/0377).....	1-9
Figure 1-6. CRS-240 AC Power Supply (AS/0376) .....	1-9
Figure 1-7. CRS-250 DC Power Supply (PL/10458-1) .....	1-9
Figure 1-8. CRS-310 RMI (PL/9579-1) .....	1-11
Figure 1-9. CRS-320 TMI EIA-232/-422 (PL/9581-1) .....	1-11
Figure 1-10. CRS-330 TMI G.703 (PL/9033-1) .....	1-11
Figure 1-11. CRS-340 TMI EIA-232/-422 or LVDS or G.703 .....	1-11
Figure 1-12. CRS-365D TMI E1 (1-4 ports) (PL/12985-2) .....	1-11
Figure 1-13. CRS-370 TMI HSSI (PL/9034-1).....	1-12
Figure 1-14. CRS-305 RMI (PL/11494-1) .....	1-13
Figure 1-15. CRS-306 RMI (PL/11494-2) .....	1-13
Figure 1-16. CRS-307 RMI (PL/11494-3) .....	1-13
Figure 1-17. CRS-315 TMI.....	1-14
Figure 1-18. CRS-316 TMI RS422 or GigE (PL/12498-1) .....	1-14
Figure 1-19. CRS-325 TMI G.703 or ASI (PL/11492-1).....	1-14
Figure 1-20. CRS-315 TMI.....	1-14
Figure 1-21. CRS-336 TMI HSSI or GigE (PL/12499-1) .....	1-14
Figure 1-22. CRS-345 TMI G.703 (4 ports) (PL/11495-1) .....	1-15
Figure 1-23. CRS-365 TMI E1 (1-4 ports) (PL/12985-1).....	1-15
Figure 1-24. CRS-350 ESC Switch – Front Panel .....	1-15
Figure 1-25. CRS-355 UDI .....	1-16
Figure 1-26. CRS-350 ESC Switch – Rear Panel .....	1-16
Figure 1-27. CRS-300 1:1 Redundancy Switch .....	1-20
Figure 1-28. CRS-280 (70/140 MHz) IF Switch .....	1-21
Figure 1-29. CRS-280L (L-Band) IF Switch .....	1-22
Figure 1-30. CRS-350 ESC Switch .....	1-23
Figure 2-1. Unpacking and Inspecting the Shipment.....	2-1
Figure 2-2. Typical Rack Mounting Configuration.....	2-4
Figure 3-1. Coaxial Connector Examples.....	3-1
Figure 3-2. D-Subminiature Connector Examples.....	3-3
Figure 3-3. CRS-300 Chassis Ground Interfaces.....	3-16
Figure 3-4. CRS-300 Chassis Power Supply Interfaces .....	3-17
Figure 3-5. Chassis AC Power Interface (CRS-240 Power Supply Module) .....	3-17
Figure 3-6. Apply AC Power .....	3-18
Figure 3-7. Replace the AC Fuses .....	3-18
Figure 3-8. Chassis DC Power Interface (CRS-250 DC Power Supply Module).....	3-19
Figure 3-9. Apply DC Power .....	3-19
Figure 4-1. Control Cable Connection Example for CRS-300 to CRS-280.....	4-5
Figure 4-2. Control Cable Connection Example for CRS-300 to CRS-280L.....	4-6
Figure 4-3. Control Cable Connection Example for CRS-300 to CRS-350.....	4-7
Figure 4-4. Control Cable Connection Example for CRS-300 to CRS-350 to CRS-280 .....	4-8

Figure 4-5. Control Cable Connection Example for CRS-300 to CRS-350 to CRS-280L ..... 4-9

Figure 4-6. IF Cabling Example – Single Transponder Configuration ..... 4-13

Figure 4-7. IF Cabling Example – Multiple Transponder Configuration ..... 4-15

Figure 4-8. CDM-625/A to CDM-625/A CnC<sup>®</sup> Cable Connection Example ..... 4-20

Figure 4-9. CRS-300 to CDM-625/A Cable Connection Example – G.703-driven Configuration ..... 4-29

Figure 4-10. CRS-300 to CDM-625/A Cable Connection Example – G.703-driven Configuration ..... 4-30

Figure 4-11. CRS-300 to CDM-625/A Cable Connection Example – Quad E1-driven Configuration ..... 4-31

Figure 4-12. CRS-300 to CDM-625/A Cable Connection Example – Sub-Mux TMIs 3 & 9 ..... 4-32

Figure 4-13. Cabling Example for CDM-625/A to CRS-350 ..... 4-35

Figure 4-14. Data Cables – CRS-300 to CDM-625/A (CDM-600/L Emulation Mode) ..... 4-36

Figure 4-15. Data Cable Connection Example – CRS-300 to CDM-570/A or CDM-570L/AL ..... 4-39

Figure 4-16. Control and Data Cables Example #1 – CRS-300 to SLM-5650/5650A ..... 4-46

Figure 4-17. Control and Data Cables Example #2 – CRS-300 to SLM-5650/5650A ..... 4-47

Figure 4-18. Control and Data Cables Example #3 – CRS-300 to SLM-5650/5650A ..... 4-48

Figure 4-19. Cabling Example for SLM-5650/5650A to CRS-350 ..... 4-49

Figure 4-20. EIA-485 Multi-drop Cabling Example – CRS-300 to CDM-Qx/QxL ..... 4-53

Figure 4-21. ‘Y’ Control Cables and EIA-530/-232 Data Cables – CRS-300 to CDM-Qx/QxL ..... 4-56

Figure 4-22. ‘Y’ Control Cables and Balanced G.703 Data Cables – CRS-300 to CDM-Qx/QxL ..... 4-57

Figure 4-23. ‘Y’ Control Cables and Unbalanced G.703 Data Cables – CRS-300 to CDM-Qx/QxL ..... 4-58

Figure 4-24. Control Cables and HSSI Data Cables – CRS-300 to CDM-Qx/QxL ..... 4-59

Figure 4-25. Control Cables and Quad E1 Data Cables – CRS-300 to CDM-Qx/QxL ..... 4-60

Figure 4-26. Control and Data Cables Example #1 – CRS-300 to CDM-710G/710GL ..... 4-64

Figure 4-27. Control and Data Cables Example #2 – CRS-300 to CDM-710G/710GL ..... 4-65

Figure 4-28. Control and Data Cables Example #1 – CRS-300 to CDM-710 ..... 4-70

Figure 4-29. Control and Data Cables Example #2 – CRS-300 to CDM-710 ..... 4-71

Figure 4-30. Control and Traffic Data Cables Example #1 – CRS-300 to CDM-700 ..... 4-78

Figure 4-31. Control and Traffic Data Cables Example #2 – CRS-300 to CDM-700 ..... 4-79

Figure 4-32. CDM-700 IP Connections – Wired-thru Example #1 ..... 4-80

Figure 4-33. CDM-700 IP Connections – Wired-thru Example #2 ..... 4-81

Figure 4-34. CDM-700 IP Connections – Wired-around Example #1 ..... 4-82

Figure 4-35. CDM-700 IP Connections – Wired-around Example #2 ..... 4-83

Figure 4-36. Data Cable Connection Example – CRS-300 to CDM-600/L ..... 4-87

Figure 4-37. Cabling Example for CDM-600/L to CRS-350 ..... 4-89

Figure 5-1. CDM-Qx/QxL Serial Communication Configuration Example ..... 5-7

Figure 5-2. CDM-Qx/QxL / CRS-300 EIA-485 Scheme ..... 5-9

Figure 5-3. CEFD P/N PC/11494x RMI PCB (CRS-307 shown) ..... 5-11

Figure 5-4. CRS-316 EIA-530 TMI Card (Jumpers Shown Open) ..... 5-12

Figure 5-5. CRS-316 “JP1” through “JP6” Jumper Detail (As Shipped) ..... 5-13

Figure 5-6. CRS-320 EIA-232/EIA-422 TMI Card (Jumpers Shown Open) ..... 5-15

Figure 5-7. CRS-340 EIA-232/-422/G.703 TMI Card (Jumpers Shown Open) ..... 5-15

Figure 5-8. CRS-336 HSSI or Ethernet TMI Card ..... 5-17

Figure 5-9. CRS-336 “JP1” and “JP2” Jumper Detail (As Shipped) ..... 5-18

Figure 5-10. CRS-370 HSSI to LVDS TMI Card (Jumper Shown Open) ..... 5-19

Figure 6-1. CRS-300 Front Panel Features ..... 6-1

Figure 6-2. CRS-300 Menu Tree ..... 6-6

Figure A-1. Networking Loop With Switches ..... A-2

Figure A-2. Hub-to-Hub With Standard Traffic Using Routers ..... A-4

Figure A-3. Wired-thru for Hub-to-Hub With Standard Traffic Using Routers ..... A-5

Figure A-4. Wired-around For Hub-to-Hub With Standard Traffic Using Routers .....A-5  
Figure A-5. Networking Loop Example.....A-6  
Figure A-6. Networking Loop Example (Simplified) .....A-6  
Figure A-7. Hub-to-Remotes With Standard Traffic Using Routers or Switches.....A-8  
Figure A-8. Wired-thru for Hub-to-Remotes With Standard Traffic Using Routers or Switches .....A-9  
Figure A-9. Wired-around for Hub-to-Remotes With Standard Traffic Using Routers or Switches .....A-9  
Figure A-10. Point-to-Multipoint Using Routers .....A-10  
Figure A-11. Wired-thru for Point-to-Multipoint Using Routers .....A-11  
Figure A-12. Wired-around for Point-to-Multipoint Using Routers.....A-11  
Figure A-13. Point-to-Multipoint Using Switches .....A-12  
Figure A-14. Wired-thru, Hub-to-Remotes, Split-path Traffic Using Switches (Point-to-Multipoint) ....A-13  
Figure A-15. Wired-around, Hub-to-Remotes, Split-path Traffic Using Switches (Point-to-Multipoint).....  
.....A-13  
Figure B-1. DCE Conversion Cable – EIA-530 to EIA-422/-449.....B-2  
Figure B-2. DCE Conversion Cable – EIA-530-to-V.35 .....B-3  
Figure B-3. Switch and Modem M&C Cable.....B-4  
Figure B-4. CDM-625/A Control Cable (CA-0000069).....B-6  
Figure B-5. SLM-5650/5650A Control Cable (CA/WR12136-1).....B-7  
Figure B-6. SLM-5650/5650A ‘Y’ Control Cable (CA/WR12842-6).....B-8  
Figure B-7. CDM-Qx/QxL Standard EIA-485 Multi-Drop Shielded Cable (CA/WR11417-1) .....B-9  
Figure B-8. CDM-Qx/QxL EIA-485 Cable Termination (CA/WR11418-1) .....B-10  
Figure B-9. CDM-Qx/QxL EIA-485 Null Modem Cable (CA/WR11419-1) .....B-11  
Figure B-10. CDM-Qx/QxL Optional EIA-485 Multi-Drop Ribbon Cable (CA/RB11423-1) .....B-12  
Figure B-11. CDM-Qx/QxL with CnC® ‘Y’ Control Cable (CA/WR12069-1) .....B-13  
Figure B-12. CDM-7XX Control Cable (CA/WR12361-1) .....B-14  
Figure B-13. EIA-232/422, EIA-530 Control and Data Cable (CA/WR0066) .....B-18  
Figure B-14. IF Cable, BNC 50Ω for CRS-280 (70/140 MHz) IF Switch (PL/0946-2) .....B-19  
Figure B-15. ASI / Balanced G.703 / IF Cable, BNC 75 Ω (PL/0813-8) .....B-20  
Figure B-16. Multi-Drop CnC® Plus Shielded Data Cable for CDM-625/A (CA-0000275) .....B-21  
Figure B-17. Ethernet Data Cable for CDM-625/A (CA-0000121).....B-22  
Figure B-18. CDM-625/A Bal G.703 Data Cable (CA-0000072) .....B-23  
Figure B-19. Quad E1 / GigE Connector Cable (PP/CAT5FF7FTGY).....B-24  
Figure B-20. HSSI Data Cable (CA/WR9189-6) .....B-25  
Figure B-21. CDM-625/A Quad E1 Data ‘Y’ Cable (CA-0000073) .....B-26  
Figure B-22. CDM-625/A Quad E1 Data Cable (CA-0000136).....B-27  
Figure B-23. CDM-625/A Quad E1 Data Adapter Cable (CA-0000163).....B-28  
Figure B-24. CDM-625/A Quad E1 Data Adapter Cable (CA-0000164).....B-29  
Figure B-25. CDM-625/A to CRS-350 Multi-purpose Cable (CA-0000074) .....B-30  
Figure B-26. Balanced G.703 Data Cable (CA/WR9038-6) .....B-31  
Figure B-27. CDM-570/A, CDM-570L/AL Balanced G.703 Data Cable (CA/WR11999-6).....B-32  
Figure B-28. Optional T1/E1 Adapter (CN-0000268) .....B-33  
Figure B-29. CDM-Qx/QxL Quad E1 Data Cable (CA/WR13018-1).....B-34  
Figure B-30. CDM-700 G.703 Data Cable (CA/RF12278-1) .....B-35  
Figure B-31. CDM-700 G.703 Data Cable (CA/RF12279-1) .....B-36  
Figure B-32. CDM-600/L Audio Data Cable (CA/WR9932-1) .....B-37  
Figure C-1. CRS-300 Addressing Scheme Example: External EIA-232 with CDM-625/A, -570/A, -570L/AL,  
-600/L Modems.....C-3



Figure C-2. CRS-300 Addressing Scheme Example: External EIA-485 with CDM-625/A, -570/A, -570L/AL, -600/L Modems ..... C-4

Figure C-3. CRS-300 Addressing Scheme Example: External EIA-232 with SLM-5650/5650A, CDM-7XX Modems ..... C-5

Figure C-4. CRS-300 Addressing Scheme Example: External EIA-485 with SLM-5650/5650A, CDM-7XX Modems ..... C-6

Figure C-5. CRS-300 Addressing Scheme Example: External EIA-232 with CDM-Qx/QxL Modems ..... C-7

Figure C-6. CRS-300 Addressing Scheme Example: External EIA-485 with CDM-Qx/QxL Modems ..... C-8

Figure C-7. CRS-300 Addressing Scheme Example: External EIA-485 with CDM-Qx/QxL Modems, EDMAC Hub-to-Hub..... C-9

BLANK PAGE

# PREFACE

---

## About this Manual

This manual provides installation and operation information for the Comtech EF Data CRS-300 1:10 Redundancy Switch. This document is intended for anyone who installs or operates the CRS-300.

## Related Documents

- Comtech EF Data CDM-625A Advanced Satellite Modem Installation and Operation Manual (CEFD P/N MN-CDM625A)
- Comtech EF Data CDM-625 Advanced Satellite Modem Installation and Operation Manual (CEFD P/N MN-CDM625)
- Comtech EF Data CDM-570A/CDM-570AL/CDMR-570AL Satellite Modem Installation and Operation Manual (CEFD P/N MN-CDM570A)
- Comtech EF Data CDM-570/CDM-570L/CDMR-570L Satellite Modem Installation and Operation Manual (CEFD P/N MN/CDM570L.IOM)
- Comtech EF Data SLM-5650A Satellite Modem Installation and Operation Manual (CEFD P/N MN-SLM5650A)
- Comtech EF Data SLM-5650 Satellite Modem Installation and Operation Manual (CEFD P/N MN/SLM5650.IOM)
- Comtech EF Data CDM-Qx/QxL Multi-Channel Satellite Modem Installation and Operation Manual (CEFD P/N MN/CDMQX.IOM)
- Comtech EF Data CDM-710G/710GL High-Speed Satellite Modem Installation and Operation Manual (CEFD P/N MN-CDM710G)
- Comtech EF Data CDM-710 Broadcast Satellite Modem Installation and Operation Manual (CEFD P/N MN/CDM710.IOM)

- Comtech EF Data CDM-700 High-Speed Satellite Modem Installation and Operation Manual (CEFD P/N MN/CDM700.IOM)
- Comtech EF Data CDM-600/600L Open Network Satellite Modem Installation and Operation Manual (CEFD P/N MN/CDM600L.IOM)
- Comtech EF Data CRS-280L 1:N Redundancy Switch Installation and Operation Manual (CEFD P/N MN/CRS280L.IOM)

---

## Conventions and References

### Patents and Trademarks

See all of Comtech EF Data's Patents and Patents Pending at <http://patents.comtechefdata.com>.

Comtech EF Data acknowledges that all trademarks are the property of the trademark owners.

### Warnings, Cautions and Notes



A **WARNING** informs you about a possible hazard that may cause death or serious injury.



A **CAUTION** informs you about a possible hazard that may cause injury or property damage.

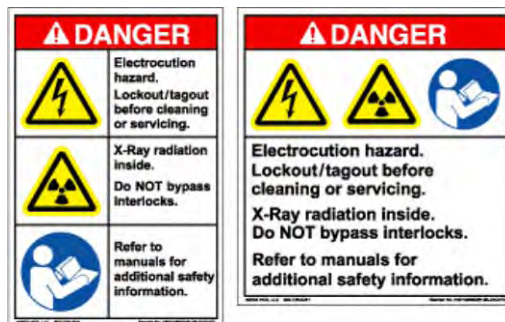


A **NOTE** gives you important information about a task or the equipment.



A **REFERENCE** directs you to additional information about a task or the equipment.

### Examples of Multi-Hazard Notices



## Recommended Standard Designations

The Electronic Industries Association (EIA) designations supersede the Recommended Standard (RS) designations. References to the old designations may be shown when depicting actual text (e.g., RS-232) displayed on Web Server pages, serial remote interfaces, Telnet Command Line Interfaces (CLIs), or unit rear panels. All other references in the manual refer to EIA designations.



**CAUTION** – You should carefully review the following information.

---

## Safety and Compliance

### Electrical Safety and Compliance

The unit complies with the **EN 60950 Safety of Information Technology Equipment (Including Electrical Business Machines)** safety standard.



**CAUTION** – IF THE UNIT IS OPERATED IN A VEHICLE OR MOVABLE INSTALLATION, MAKE SURE THE UNIT IS STABLE. OTHERWISE, EN 60950 SAFETY IS NOT GUARANTEED.

### Electrical Installation



**CAUTION** – CONNECT THE UNIT TO A POWER SYSTEM THAT HAS SEPARATE GROUND, LINE AND NEUTRAL CONDUCTORS. DO NOT CONNECT THE UNIT WITHOUT A DIRECT CONNECTION TO GROUND.

### Operating Environment



**CAUTION** – DO NOT OPERATE THE UNIT IN ANY OF THESE EXTREME OPERATING CONDITIONS

- AMBIENT TEMPERATURES LESS THAN 0° C (32° F) OR MORE THAN 50° C (122° F).
- PRECIPITATION, CONDENSATION, OR HUMID ATMOSPHERES OF MORE THAN 95% RELATIVE HUMIDITY.
- UNPRESSURIZED ALTITUDES OF MORE THAN 2000 METRES (6561.7 FEET).
- EXCESSIVE DUST.
- FLAMMABLE GASES.
- CORROSIVE OR EXPLOSIVE ATMOSPHERES.

## European Union Radio Equipment and Telecommunications Terminal Equipment (R&TTE) Directive (1999/5/EC) and EN 301 489-1

Independent testing verifies that the unit complies with the European Union R&TTE Directive, its reference to EN 301 489-1 (*Electromagnetic compatibility and Radio spectrum Matters [ERM]; ElectroMagnetic Compatibility [EMC] standard for radio equipment and services, Part 1: Common technical requirements*), and the Declarations of Conformity for the applicable directives, standards, and practices that follow:

---

### European Union Electromagnetic Compatibility (EMC) Directive (2004/108/EC)

- **Emissions: EN 55022 Class A** – Limits and Methods of Measurement of Radio Interference Characteristics of Information Technology Equipment.
- **Immunity: EN 55024** – Information Technology Equipment: Immunity Characteristics, Limits, and Methods of Measurement.
- **EN 61000-3-2** – Harmonic Currents Emission
- **EN 61000-3-3** – Voltage Fluctuations and Flicker.
- **Federal Communications Commission Federal Code of Regulation FCC Part 15, Subpart B.**



**CAUTION – TO ENSURE THAT THE UNIT COMPLIES WITH THESE STANDARDS, OBEY THESE INSTRUCTIONS:**


- **Use coaxial cable that is of good quality for connections to the L-Band Type 'N' Rx (receive) female connector.**
- **Use Type 'D' connectors that have back-shells with continuous metallic shielding.**





**Type 'D' cabling must have a continuous outer shield (either foil or braid, or both). The shield must be bonded to the back-shell.**

- **Operate the unit with its cover on at all times.**

---

## European Union Low Voltage Directive (LVD) (2006/95/EC)

Symbol	Description
<HAR>	Type of power cord required for use in the European Community.
	CAUTION: <b>Double-pole/Neutral Fusing</b> ACHTUNG: <b>Zweipolige bzw. Neutralleiter-Sicherung</b>

International Symbols			
Symbol	Definition	Symbol	Definition
	Alternating Current		Protective Earth
	Fuse		Chassis Ground



For additional symbols, see the Warnings, Cautions and Notes listed earlier in this Preface.

---

## European Union RoHS Directive (2002/95/EC)

This unit satisfies (with exemptions) the requirements specified in the European Union Directive on the Restriction of Hazardous Substances in Electrical and Electronic Equipment (EU RoHS, Directive 2002/95/EC).

---

## European Union Telecommunications Terminal Equipment Directive (91/263/EEC)

In accordance with the European Union Telecommunications Terminal Equipment Directive 91/263/EEC, the unit should not be directly connected to the Public Telecommunications Network.

---

## CE Mark

Comtech EF Data declares that the unit meets the necessary requirements for the CE Mark.

---

## Product Support

For all product support, please call:

**+1.240.243.1880**

**+1.866.472.3963 (toll free USA)**

---

## **Comtech EF Data Headquarters**

**<http://www.comtechefdata.com>**

**Comtech EF Data Corp.**

**2114 West 7th Street**

**Tempe, Arizona USA 85281**

**+1.480.333.2200**

---

## **Warranty Policy**

Comtech EF Data products are warranted against defects in material and workmanship for a specific period from the date of shipment, and this period varies by product. In most cases, the warranty period is two years. During the warranty period, Comtech EF Data will, at its option, repair or replace products that prove to be defective. Repairs are warranted for the remainder of the original warranty or a 90 day extended warranty, whichever is longer. Contact Comtech EF Data for the warranty period specific to the product purchased.

For equipment under warranty, the owner is responsible for freight to Comtech EF Data and all related customs, taxes, tariffs, insurance, etc. Comtech EF Data is responsible for the freight charges only for return of the equipment from the factory to the owner. Comtech EF Data will return the equipment by the same method (i.e., Air, Express, Surface) as the equipment was sent to Comtech EF Data.

All equipment returned for warranty repair must have a valid RMA number issued prior to return and be marked clearly on the return packaging. Comtech EF Data strongly recommends all equipment be returned in its original packaging.

Comtech EF Data Corporation's obligations under this warranty are limited to repair or replacement of failed parts, and the return shipment to the buyer of the repaired or replaced parts.

## **Limitations of Warranty**

The warranty does not apply to any part of a product that has been installed, altered, repaired, or misused in any way that, in the opinion of Comtech EF Data Corporation, would affect the reliability or detracts from the performance of any part of the product, or is damaged as the result of use in a way or with equipment that had not been previously approved by Comtech EF Data Corporation.



The warranty does not apply to any product or parts thereof where the serial number or the serial number of any of its parts has been altered, defaced, or removed.

The warranty does not cover damage or loss incurred in transportation of the product. The warranty does not cover replacement or repair necessitated by loss or damage from any cause beyond the control of Comtech EF Data Corporation, such as lightning or other natural and weather related events or wartime environments.

The warranty does not cover any labor involved in the removal and or reinstallation of warranted equipment or parts on site, or any labor required to diagnose the necessity for repair or replacement.

The warranty excludes any responsibility by Comtech EF Data Corporation for incidental or consequential damages arising from the use of the equipment or products, or for any inability to use them either separate from or in combination with any other equipment or products.

A fixed charge established for each product will be imposed for all equipment returned for warranty repair where Comtech EF Data Corporation cannot identify the cause of the reported failure.

## **Exclusive Remedies**

Comtech EF Data Corporation's warranty, as stated is in lieu of all other warranties, expressed, implied, or statutory, including those of merchantability and fitness for a particular purpose. The buyer shall pass on to any purchaser, lessee, or other user of Comtech EF Data Corporation's products, the aforementioned warranty, and shall indemnify and hold harmless Comtech EF Data Corporation from any claims or liability of such purchaser, lessee, or user based upon allegations that the buyer, its agents, or employees have made additional warranties or representations as to product preference or use.

The remedies provided herein are the buyer's sole and exclusive remedies. Comtech EF Data shall not be liable for any direct, indirect, special, incidental, or consequential damages, whether based on contract, tort, or any other legal theory.



# Chapter 1. INTRODUCTION

---

## 1.1 Overview

This chapter provides the description and specifications for the CRS-300 1:10 Redundancy Switch and its optional IF and ESC Switch components:



CRS-300 1:10 Redundancy Switch



[OPTIONAL]  
CRS-280 IF Switch (70/140MHz)



[OPTIONAL]  
CRS-280L IF Switch (L-Band)



[OPTIONAL]  
CRS-350 Engineering Service  
Channel (ESC) Switch

The CRS-300 1:10 Redundancy Switch (referred to throughout this manual as the Switch) provides fully automatic protection of traffic circuits in the case of equipment failure. You can configure the CRS-300 to back up (replace) a Traffic modem when a Unit Fault and/or a Tx/Rx Traffic Fault occurs.

The CRS-300 is intended for hub applications. It is compatible for use with the Comtech EF Data modems specified in **Table 1-1**. While the Switch is capable of controlling any of these modems, note that it is important that only one type of modem may be connected to the Switch within a given redundancy system; this is because the Redundant Modem must operate identically to the configured Traffic Modem.

A key feature of the CRS-300 architecture is its ability to allow the Redundant Modem to ‘bridge’ a Traffic Modem. The Switch automatically configures the Redundant Modem to match the bridged modem’s configuration. The Switch also copies the bridged modem’s terrestrial transmit clock/data and routes it to the Redundant Modem.

When used with the CRS-280/280L, the CRS-300 additionally routes the bridged modem’s Rx IF. Because this live traffic is used at all times to verify performance, no external test equipment is needed to determine the health of the Redundant Modem.

**Construction features** – The CRS-300 is modular in construction – all replaceable modules install into slots in the back panel. This includes the controller, Redundant Modem Interface (RMI), Traffic Modem Interfaces (TMIs), and Power Supply Units (PSUs).

Because power consumption is below 30 watts for a fully populated Switch, the CRS-300 requires no fan cooling.

**Key Reliability Features** – The CRS-300 incorporates the following key reliability features:

- Dual, independent, AC or DC power supplies.
- Traffic Modems with differing data types can all be supported by the Redundant Modem – the exception to this is the CDM-Qx/QxL and, with some limitations, the CDM-625/A.
- Primary traffic paths are maintained, error-free, when power is removed.
- TMIs can be completely removed from the CRS-300, with cables still attached, and traffic is not interrupted or affected.
- RMI and/or TMIs can be replaced without disturbing other traffic circuits.

**Interfaces** – The CRS-300 supports all of the modems’ available interface types. This includes EIA-530/-422, V.35, Sync EIA-232, ASI, Balanced or Unbalanced G.703, LVDS, Single-port Ethernet Bridge Mode, and HSSI.

**Ease of Connection** – The modular design of the Switch simplifies cabling connections between the Switch and the Redundant and Traffic Modems, thereby reducing the number of potential failure points within the rack enclosure installation:

- **When you use the CDM-625/A, CDM-570/A, CDM-570L/AL, or CDM-600/L modems** – The multi-protocol interface requires only a single cable for each modem. This cable carries all data signals, alarm information, and the serial remote control interface.

*If you use the G.703 interfaces*, you will need only one additional cable for each modem.

- **When you use the CDM-Qx/QxL modems** – You will need to connect an additional EIA-485 multi-drop cable from the Switch to all modems. This cable enables remote control interface capability.
- **For EIA-232/EIA-485 M&C User connections** – A direct user-to-modem serial EIA-232/-485 communication connection is not permissible when connected to the Switch. You must instead connect to the DB-9 "Remote" connector on the CRS-230 System Controller that is installed on the Switch.



### Appendix C. ADDRESSING SCHEME INFORMATION

**TMI Monitoring** – Terrestrial user clock and data signals to and from a Traffic Modem are routed through a TMI via a set of relays. This is arranged so that the de-energized (unpowered) state connects the data signals directly through to the Traffic Modem. If the power supplies to the system are lost, or if a traffic-carrying TMI is removed, no interruption of the traffic occurs. It should also be noted that, in normal circumstances where the Redundant Modem is not in service, no data is carried through the CRS-300 backplane – all data is routed via the TMI.

**CRS-280/280L Option** – **Figure 1-2** in **Sect. 1.1.2** shows an operational schematic for the optional CRS-280/280L interface:

- The CRS-280 (70/140 MHz) Switch is necessary when one or more modems within the redundancy system connect to more than one up/down converter. This occurs when the modems connect to more than one transponder on the same antenna polarization, or when modem redundancy needs to span two or more polarizations or antennas.
- The CRS-280L (L-Band) Switch is necessary when one or more modems within the redundancy system connect to the other polarization of the antenna or to multiple antennas.

The system may forego using the CRS-280/280L and, in its place, passively combine or split the modulator outputs and demodulator inputs when the entire group of modems is connected to the same up/down converter. In these applications, the CRS-300 mutes the faulted modem's Tx carrier and enables the standby unit's carrier.



### Comtech EF Data CRS-280L 1:N Redundancy Switch Installation and Operation Manual (CEFD P/N MN/CRS280L.IOM)

**CRS-350 Option** – **Figure 1-24** through **Figure 1-26** in **Sect. 1.4** show details of the CRS-350 ESC Switch. You may add this unit if you require protection of the IDR overhead signals (backward alarms, audio ESC, data ESC, etc.).

### 1.1.1 System-Level Block Diagram

Figure 1-1 shows the system-level block diagram of the CRS-300 1:10 Redundancy Switch, including the optional CRS-280/280L IF and CRS-350 ESC Switches.

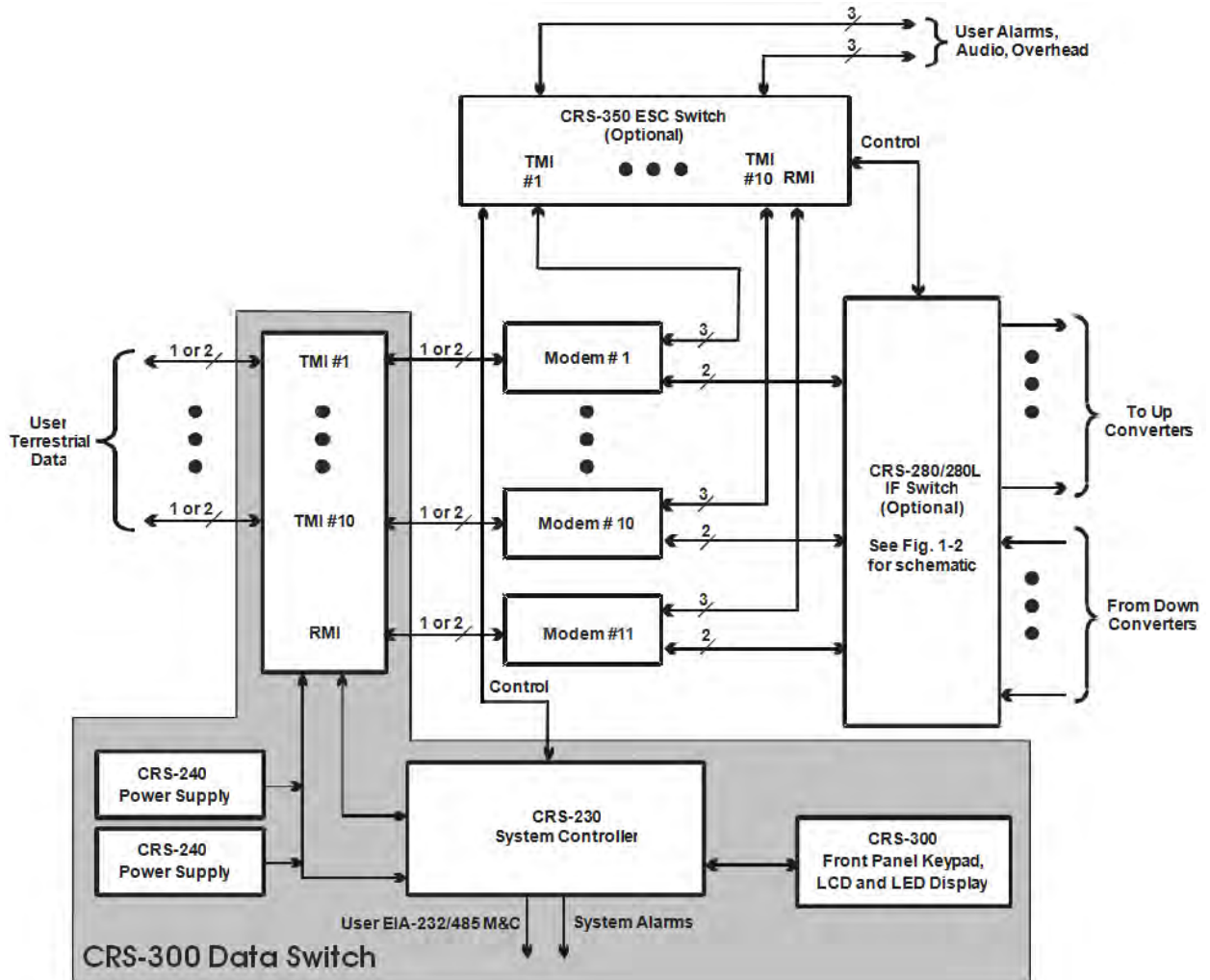


Figure 1-1. Typical Redundancy System-Level Block Diagram

### 1.1.2 CRS-280/280L Functional Schematic

Figure 1-2 provides an operational schematic for the CRS-280/280L IF Switch.

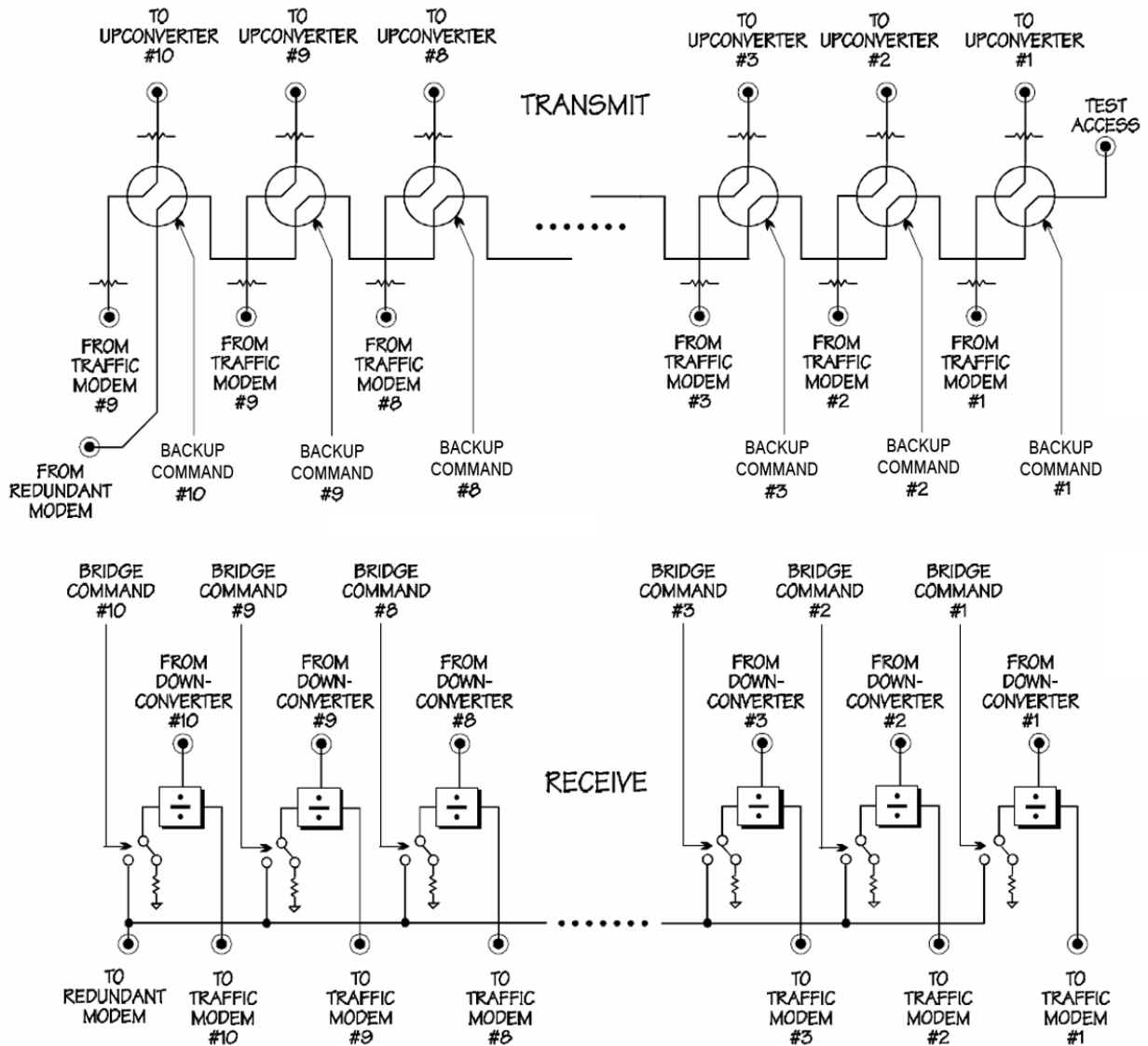




Figure 1-2. CRS-280/280L IF Switch Functional Schematic

## 1.2 CRS-300 Compatibility

**Table 1-1** shows the Comtech EF Data modems that are compatible for use with the CRS-300 1:10 Redundancy Switch.

**Table 1-1. CRS-300 Compatibility Table**

Modem	Optional Switches
CDM-625/A <sup>Note 1</sup>	CRS-280L IF Switch (L-Band) CRS-350 ESC Switch (IDR Overhead)
CDM-570/A <sup>Note 2</sup>	CRS-280 IF Switch (70/140 MHz)
CDM-570L/AL <sup>Note 2</sup>	CRS-280L IF Switch (L-Band)
SLM-5650/5650A	CRS-280 IF Switch (70/140 MHz) CRS-280L IF Switch (L-Band) CRS-350 ESC Switch (IDR Overhead)
CDM-Qx	CRS-280 IF Switch (70/140 MHz)  <b>Up to one modulator and one demodulator allowed per CDM-Qx.</b>
CDM-QxL	CRS-280L IF Switch (L-Band)  <b>Up to one modulator and one demodulator allowed per CDM-QxL.</b>
CDM-710G/710GL CDM-710 CDM-700	CRS-280 IF Switch (70/140 MHz) CRS-280L IF Switch (L-Band)
CDM-600 <sup>Note 2</sup>	CRS-280 IF Switch (70/140 MHz) CRS-350 ESC Switch (IDR Overhead)
CDM-600L <sup>Note 2</sup>	CRS-280L IF Switch (L-Band) CRS-350 ESC Switch (IDR Overhead)

### Compatibility Notes:

- 1) The CDM-625 and CDM-625A Advanced Satellite Modems, with available CDM-600 Emulator Mode, serve as operationally transparent replacement units for the CDM-600/L Open Network Satellite Modems.
- 2) The CDM-570A and CDM-570AL Satellite Modems can operate either in legacy CDM-570 Compatibility Mode or in the normal CDM-570A Mode. If the CDM-570A/AL is in a network of CDM-570/Ls, then it will need to be configured for CDM 570 Compatibility mode.
- 3) The CiM-25, Comtech EF Data's low-cost Internet Protocol (IP) Monitor & Control (M&C) interface for existing CEFD modems, is not compatible for use on modems operating within a CRS-300 redundancy system. Taking this prohibition of use under further consideration, the CiM-25 should not, *under any circumstances*, be connected to the Remote port on the CRS-300's CRS-230 Controller card for control of the Switch and modems.

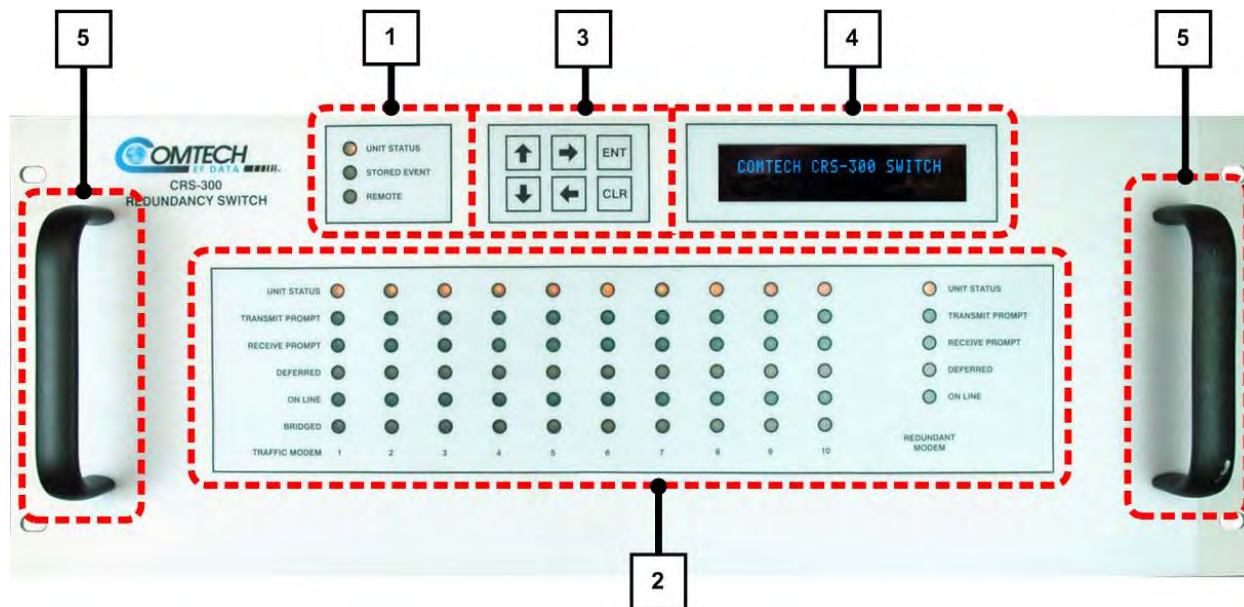


## 1.3 Description of CRS-300 Features

### 1.3.1 Front Panel

Figure 1-3 shows the CRS-300 Front Panel features, and the manual chapter sections where you may reference additional information about that feature.

The CRS-300 is constructed as a 4RU-high, rack-mounting chassis that can be freestanding, if desired.



Feature	Description	Function	Chapter Sect.
1	<b>Unit States LED Indicators</b>	These LEDs show a summary status of the Switch.	6.1.2.1
2	<b>Modem Status LED Indicators</b>	These LEDs show a summary status of the Traffic and Redundant modems.	6.1.2.2
3	<b>Keypad</b>	Use the keypad to enter data. The keypad has six individual key switches mounted behind a sealed membrane overlay. The keys have a positive 'click' action that gives tactile feedback.	6.1.1
4	<b>Vacuum Fluorescent Display (VFD)</b>	The VFD shows data, menus, prompts and messages. The VFD is an active display with adjustable brightness. It shows two lines of 24 characters each. Nested menus show all available options and prompts that guide you in carrying out required actions.	6.1.3
5	<b>Rack Handles</b>	In a rack enclosure, these handles help you install and remove the unit.	2.2

**Figure 1-3. CRS-300 Front Panel Features**

### 1.3.2 Rear Panel



- Chapter 3. SWITCH CONNECTORS AND PINOUTS
- Chapter 5. MODEM, RMI/TMI, AND SWITCH CONFIGURATION

Figure 1-4 shows the back panel of the CRS-300 with an example array of installed TMI cards.



Because the RMI can have the capability for several TMIs, depending on user requirements the CRS-300 may be able to use several different TMI cards simultaneously.

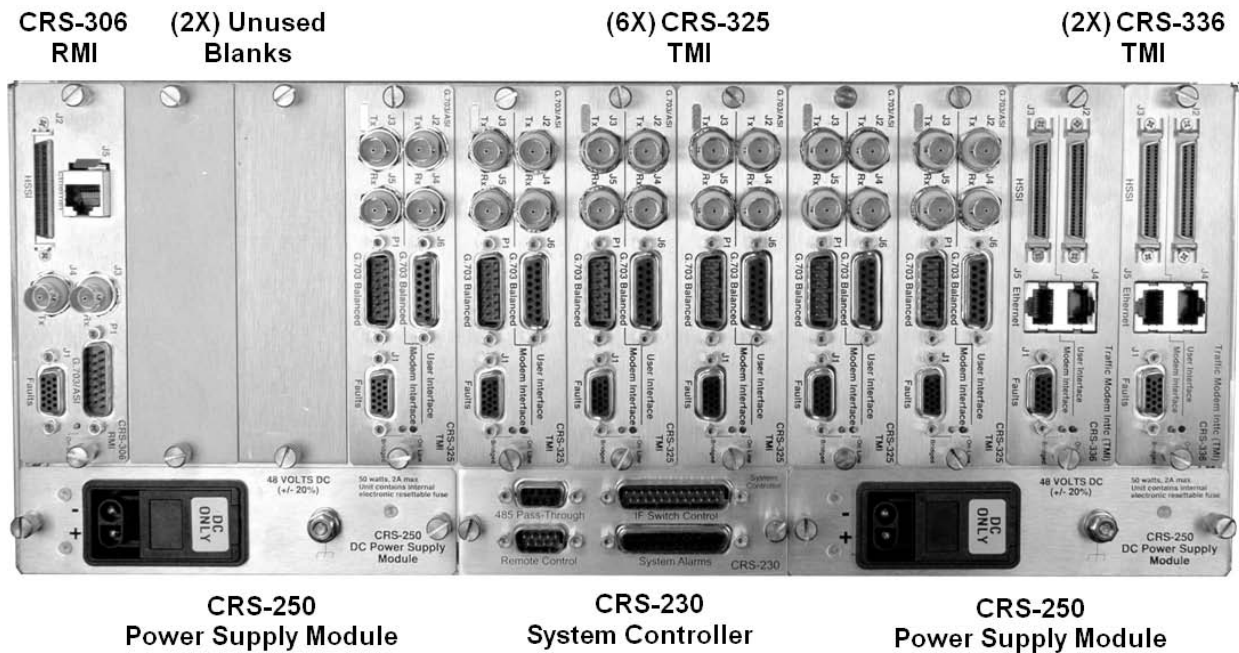


Figure 1-4. CRS-300 Rear Panel – Configuration Example

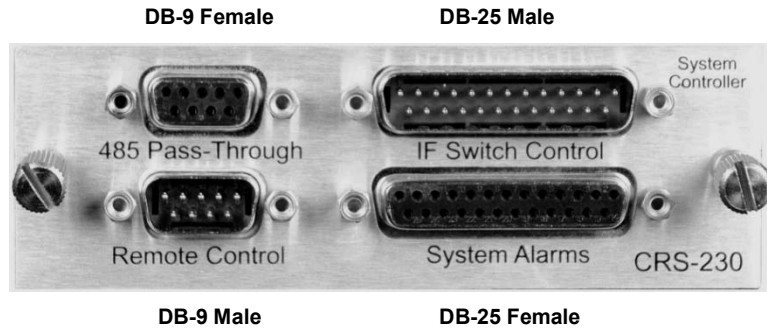
### 1.3.3 Plug-in Module (Card) Assemblies



#### Chapter 3. SWITCH CONNECTORS AND PINOUTS

#### 1.3.3.1 CRS-300 System Controller Card Assembly

Figure 1-5. CRS-230  
System Controller  
(AS/0377)



#### 1.3.3.2 Power Supply Card Assemblies

Figure 1-6. CRS-240  
AC Power Supply  
(AS/0376)



Figure 1-7. CRS-250  
DC Power Supply  
(PL/10458-1)



### 1.3.3.3 Modem Interface Cards

#### 1.3.3.3.1 CDM-625/A, CDM-570/A, CDM-570L/AL, CDM-600/L Interface Cards

The following tables indicate which TMI (Traffic Modem Interface) cards and which RMI (Redundant Modem Interface) cards should be used with each modem and data type:

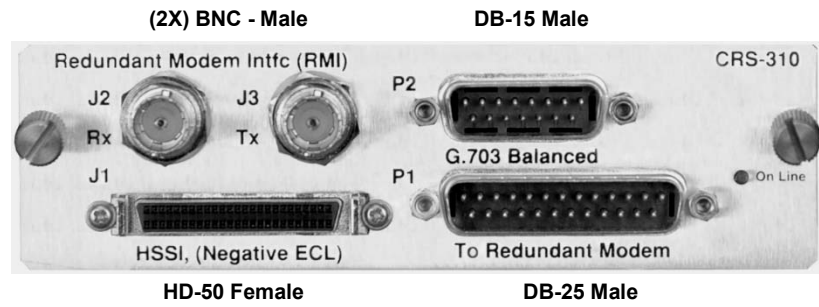
CDM-625/A Modem			
Data Type	TMI Type	RMI Type	
EIA-422, V.35	CRS-316 Notes 5, 6	CRS-310	
10/100 Ethernet Note 4			
ASJ Notes 5, 6	CRS-325 Notes 5, 6		
G.703 Bal (DDI, IDO, DDO, IDI) Note 2 G.703 Unbal Note 2			
G.703 Bal (DDI, IDO, DDO, IDI) Note 2 G.703 Unbal (DDI, IDO, DDO, IDI) Note 2	CRS-330		
HSSI 10/100 Ethernet Note 4	CRS-336 Notes 5, 6		
EIA-422, V.35, LVDS G.703 Bal (DDI, IDO, DDO, IDI) Note 2 G.703 Unbal Notes 1, 2	CRS-340 Note 3		
Quad E1	CDS-365D Notes 5, 6		
CDM-570/A, CDM-570L/AL Modems			
Data Type	TMI Type		RMI Type
G.703 T1/E1 Bal/Unbal	CRS-330 or CRS-340	CRS-310	
EIA-422, V.35, EIA-232	CRS-340		
CDM-600/L Modems, CDM-625/A Modem (in CDM-600 Emulator Mode)			
Data Type	TMI Type	RMI Type	
G.703 Bal (DDI, IDO, DDO, IDI) Notes 1, 2 G.703 Unbal (DDI, IDO, DDO, IDI) Notes 1, 2	CRS-330	CRS-310	
EIA-422/V.35, EIA-232, LVDS G.703 Bal (DDI, IDO, DDO, IDI) Notes 1, 2 G.703 Unbal Notes 1, 2	CRS-340 Note 3		
Converts LVDS (Modem) to/from HSSI (User)	CRS-370		

**Notes:**

- 1) For CDM-600/L modem to switch data (Bal and Unbal) use a DB-15 to DB-15 data cable.
- 2) For CDM-625/A modem to switch data (Bal and Unbal) use a DB-9 to DB-15 data cable.
- 3) As of September 2008, the CRS-320 TMI is obsolete. Use the CRS-340 TMI in its place.
- 4) For CDM-625/A where the terrestrial data type is Ethernet, you can use only one of any four Ethernet ports on the CDM-625/A rear panel in Ethernet Bridge Mode.
- 5) From Redundant Modem to RMI, use a DB-25 to DB-25 Control cable.
- 6) From Traffic Modem to TMI, use a DB-9 to HD-15 Control cable.

### 1.3.3.3.1.1 RMI Card

Figure 1-8. CRS-310 RMI  
(PL/9579-1)



### 1.3.3.3.1.2 TMI Cards

Figure 1-9. CRS-320 TMI  
EIA-232/-422 (PL/9581-1)

**OBSOLETE  
REPLACED BY  
CRS-340**

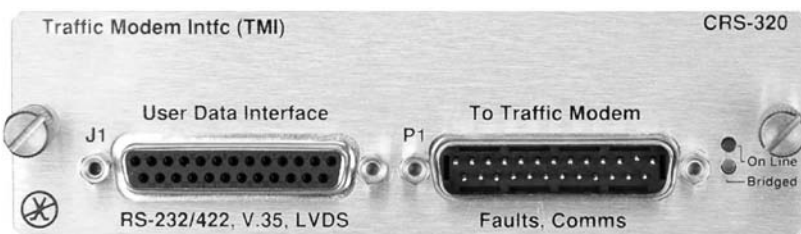


Figure 1-10. CRS-330  
TMI G.703 (PL/9033-1)

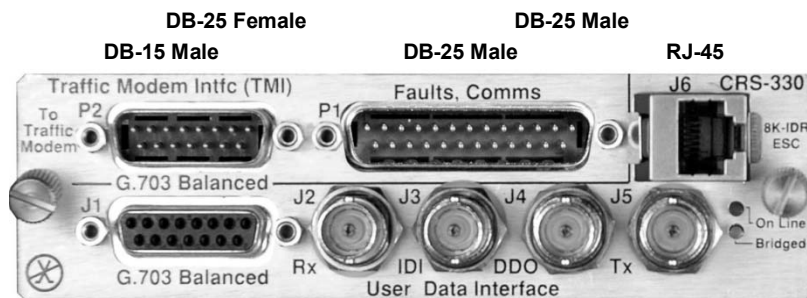


Figure 1-11. CRS-340  
TMI EIA-232/-422 or  
LVDS or G.703  
(PL/9387-1)

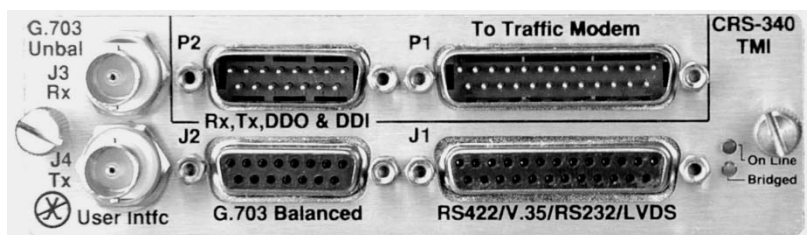
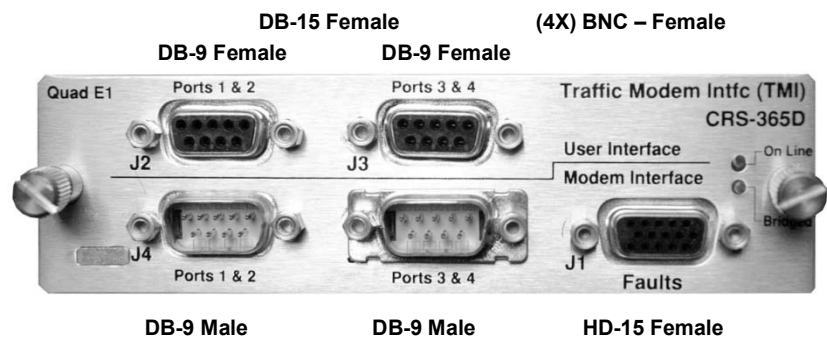


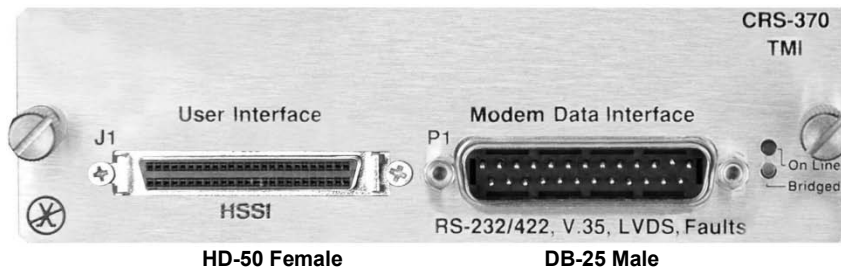
Figure 1-12. CRS-365D  
TMI E1 (1-4 ports)  
(PL/12985-2)

**FOR USE WITH  
CDM-625/A ONLY**



**Figure 1-13. CRS-370  
TMI HSSI (PL/9034-1)**

**FOR USE WITH  
CDM-600/L ONLY**



Depending on the traffic data type, the appropriate jumper settings are provided on the TMI to ensure proper operation for RTS/CTS, DTR/DSR (CRS-320 (obsolete) or CRS-340 TMIs) and CA/TA (CRS-370 TMI). See Chapter 5. MODEM, TMI AND SWITCH CONFIGURATION for this important configuration information.

### 1.3.3.3.2 SLM-5650/5650A, CDM-Qx/QxL, CDM-710G/710GL, CDM-710, CDM-700 Interface Cards

The following tables indicate the TMI (Traffic Modem Interface) and RMI (Redundant Interface) cards that should be used with each modem and data type:

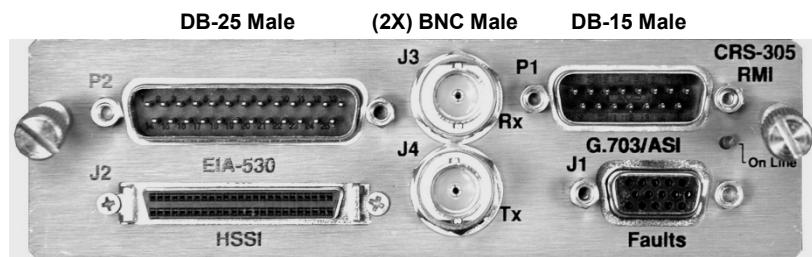
SLM-5650/5650A Modems		
Data Type	TMI Type	RMI Type <sup>Note 3</sup>
MIL-STD-188-114, EIA-530/-422 or Single-port Ethernet Bridge Mode	CRS-316 <sup>Note 1</sup>	CRS-306 (GigE only) CRS-307
G.703 Bal/UnBal	CRS-325	CRS-306
HSSI or Single-port Ethernet Bridge Mode	CRS-336 <sup>Notes 2, 4</sup>	CRS-306/307
CDM-Qx/QxL Modems		
Data Type	TMI Type	RMI Type
EIA-530/-422/V.35, EIA-232	CRS-316 <sup>Note 1</sup>	CRS-305
G.703 T1/E1 Bal D&I, Unbal	CRS-325	
HSSI	CRS-336 <sup>Note 2</sup>	
Quad E1	CRS-365	
CDM-710G/710GL Modems		
Data Type	TMI Type	RMI Type
G.703 Unbal	CRS-325	CRS-306
HSSI or GigE	CRS-336 <sup>Note 4</sup>	
CDM-710 Modem		
Data Type	TMI Type	RMI Type
ASI	CRS-325	CRS-306
HSSI or GigE	CRS-336 <sup>Note 4</sup>	
CDM-700 Modem		
Data Type	TMI Type	RMI Type <sup>Note 3</sup>
OC3 Copper	CRS-325	CRS-306
HSSI or GigE	CRS-336 <sup>Notes 2, 4</sup>	
G.703 (E3/T3/STS-1) UnBal 1 to 4 Ports	CRS-345	

**Notes (as of April 2007):**

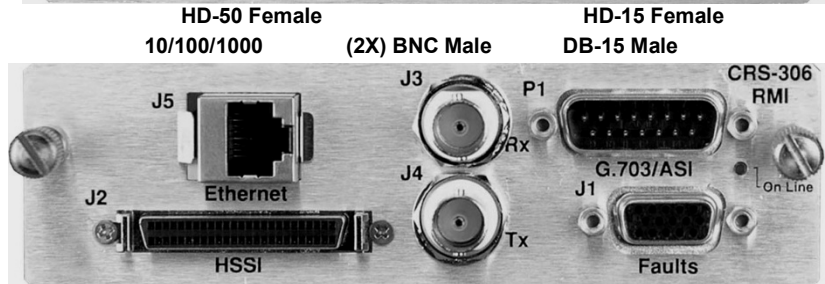
- 1) Use CRS-316 instead of CRS-315. To maintain older TMIs in the field, Switch firmware must also support the CRS-315.
- 2) Use CRS-336 instead of CRS-335. To maintain older TMIs in the field, Switch firmware must also support the CRS-335.
- 3) Use CRS-306 instead of CRS-305. To maintain older RMIs in the field, Switch firmware must also support the CRS-335.
- 4) For modems where the terrestrial data type is Ethernet, you can use only one Ethernet port in Single-port Ethernet Bridge Mode, on the modem rear panel (when using the optional Ethernet interface).

**1.3.3.3.2.1 RMI Cards**

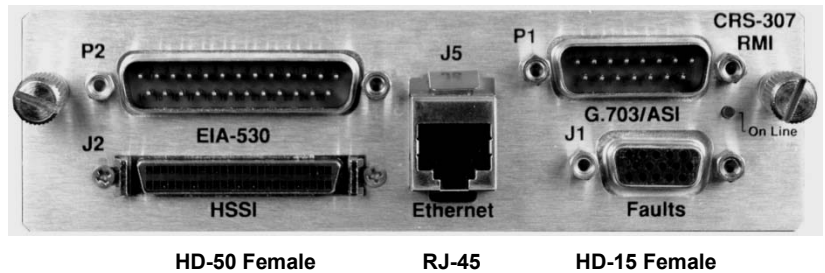
**Figure 1-14. CRS-305 RMI (PL/11494-1)**



**Figure 1-15. CRS-306 RMI (PL/11494-2)**

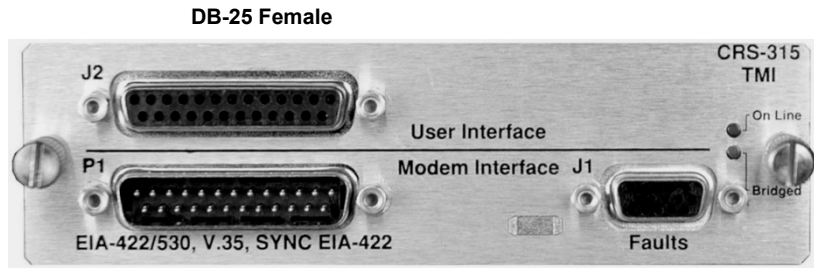


**Figure 1-16. CRS-307 RMI (PL/11494-3)**

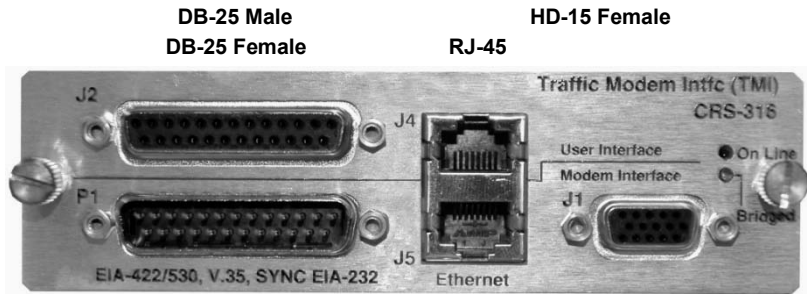


### 1.3.3.3.2 TMI Cards

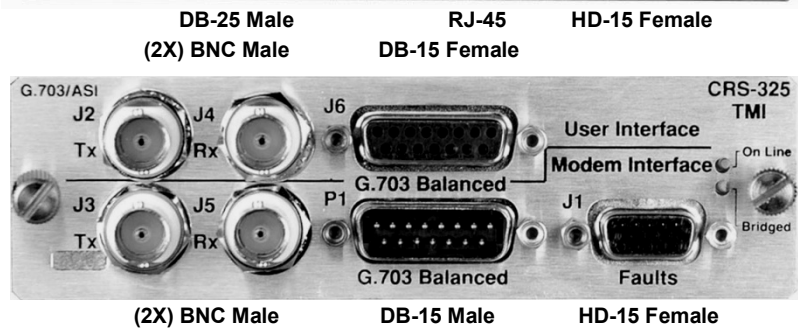
**Figure 1-17. CRS-315 TMI  
(PL/11493-1)**  
**OBSOLETE**



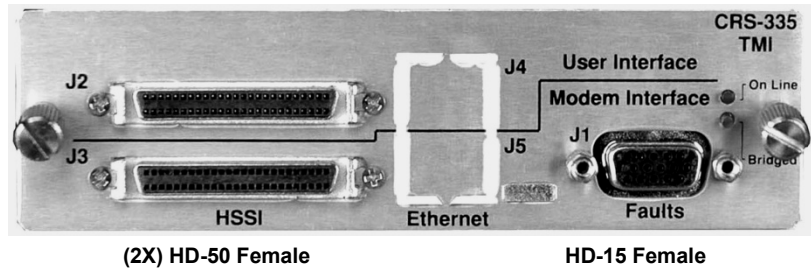
**Figure 1-18. CRS-316 TMI  
RS422 or GigE  
(PL/12498-1)**  
**ALSO USED WITH  
CDM-625/A**



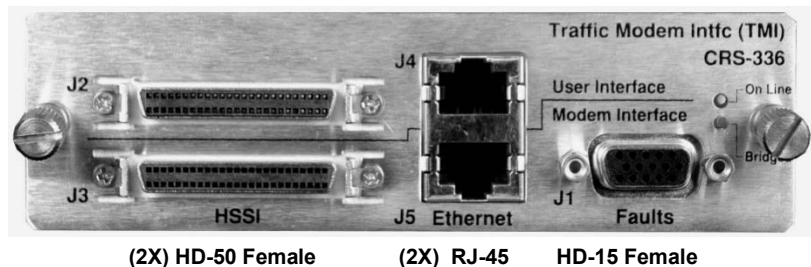
**Figure 1-19. CRS-325 TMI  
G.703 or ASI (PL/11492-1)**  
**ALSO USED WITH  
CDM-625/A**



**Figure 1-20. CRS-315 TMI  
(PL/11493-1)**  
**OBSOLETE**



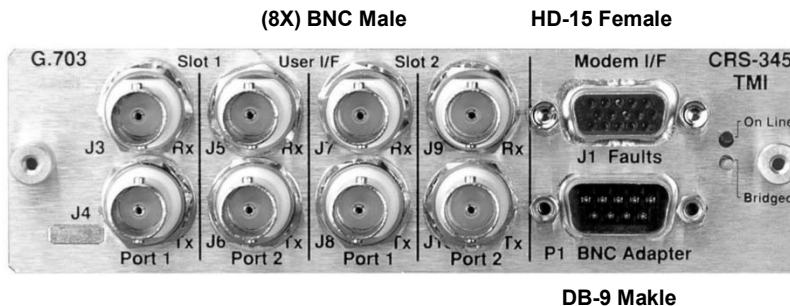
**Figure 1-21. CRS-336 TMI  
HSSI or GigE (PL/12499-1)**  
**ALSO USED WITH  
CDM-625/A**





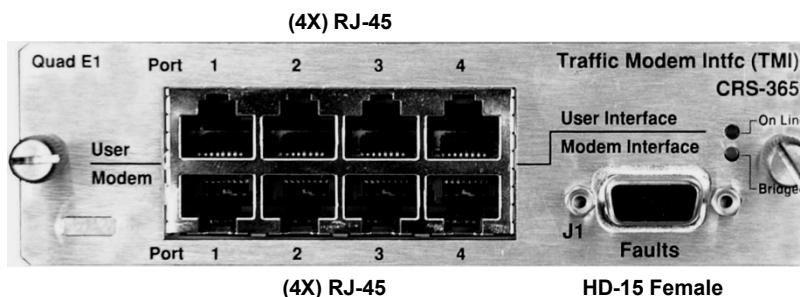
**Figure 1-22. CRS-345 TMI  
G.703 (4 ports)  
(PL/11495-1)**

**FOR USE WITH  
CDM-700 ONLY**



**Figure 1-23. CRS-365 TMI  
E1 (1-4 ports) (PL/12985-1)**

**FOR USE WITH  
CDM-Qx/QxL ONLY**



## 1.4 Optional CRS-350 ESC Switch



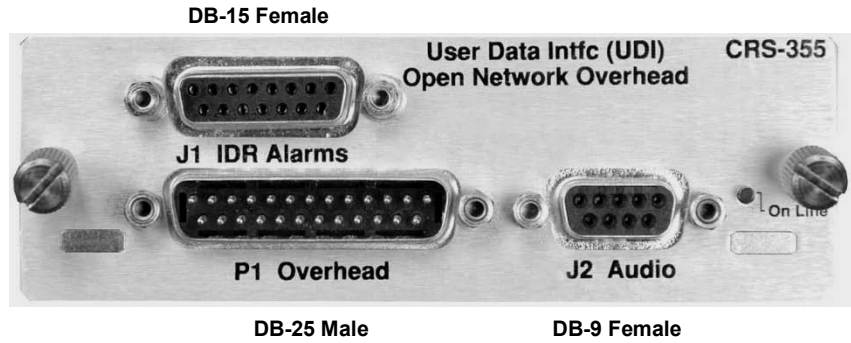
**Figure 1-24. CRS-350 ESC Switch – Front Panel**

The CRS-350 Engineering Service Channel (ESC) Switch is intended for use with the CDM-600/L, CDM-625/A, and SLM-5650/5650A modems. The CRS-350 is constructed as a 3RU-high, rack-mounting chassis designed for mounting to the back of a 19-inch rack. See **Figure 2-2** in **Chapter 2. INSTALLATION** for an installation example.

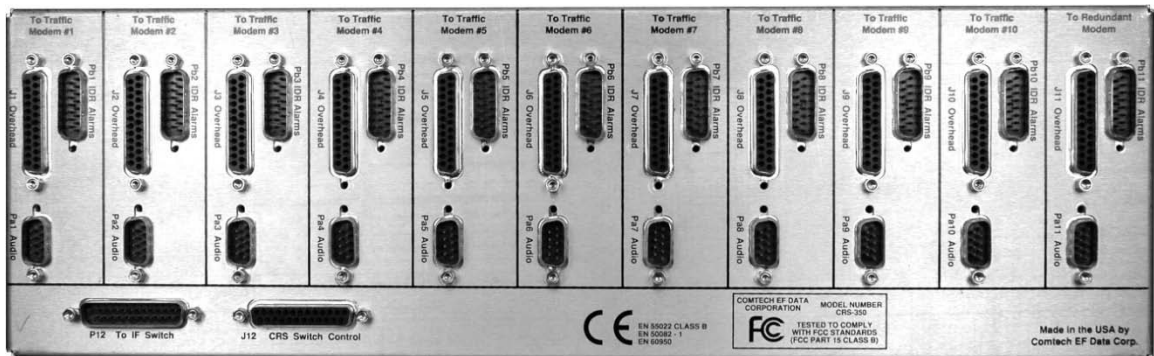
**Figure 1-24** shows the user interface side of the CRS-350 ESC Switch. Here, you have access to the Audio, Overhead, and IRD connector interfaces featured on the CRS-355 User Data Interface (UDI) (**Figure 1-25**).

**Figure 1-25** shows the user interface for one of the (10) CRS-355 UDIs that plug in at the front panel of the CRS-350 ESC Switch. As explained in detail in the pertinent modem sections of **Chapter 4. CABLES AND CONNECTIONS**, your equipment should be connected directly to the ports on this UDI instead of connecting directly to the Traffic Modem’s “Audio”, “Overhead”, and “IDR Alarms” ports.

**Figure 1-25.**  
**CRS-355 UDI**



The rear of the CRS-350, shown in **Figure 1-26**, contains these same three connectors that correlate with their respective connectors on each of the modems.



**Figure 1-26. CRS-350 ESC Switch – Rear Panel**

## 1.5 Summary of Specifications

### 1.5.1 CRS-300 1:10 Redundancy Switch Specifications

Characteristic	Requirement
Switch Type	1:N Redundancy Switch system ( N=10 max), Bridging architecture C161 control processor
Compatible Modems	<ul style="list-style-type: none"> <li>• CDM-625A</li> <li>• CDM-625</li> <li>• CDM-570A/AL</li> <li>• CDM-570/570L</li> <li>• SLM-5650A</li> <li>• SLM-5650</li> <li>• CDM-Qx/QxL</li> <li>• CDM-710G/710GL</li> <li>• CDM-710</li> <li>• CDM-700</li> <li>• CDM-600/L</li> </ul>
Operating Modes	<ul style="list-style-type: none"> <li>• Fully automatic or manual</li> <li>• Force Traffic Modem to Redundant Modem</li> <li>• Remove selected Traffic Modem from control</li> <li>• Programmable holdoff-to-backup and holdoff-to-restore (from 1 to 99 seconds)</li> </ul>
Switching Conditions	Switch to Redundant Modem following a Unit fault, Tx or Rx traffic faults
Switching Time	9 seconds max. (Delay interval set to minimum, 1 sec)
IF Switching	<ul style="list-style-type: none"> <li>• CRS-300 without CRS-280/280L IF Switch: IF ON / OFF control through the Switch controller.</li> <li>• CRS-300 with CRS-280/280L: all modems outputs ON all the time.</li> </ul>
Temperature	<ul style="list-style-type: none"> <li>• 0 to +50°C (32 to 122°F) Operating</li> <li>• 50 to 100°C (122 to 212°F) Storage</li> </ul>
Humidity	95% at +40°C (104°F), Non-condensing
CE Mark	EMC and Safety
AC Prime Power	Two independent inputs: 100 to 250 VAC, 50/60 Hz, at 25 watts VA max
DC Prime Power	48 (38 to 60) VDC 25 watts max
Redundant Modem Signal Source	Any one of the 10 traffic paths (bridge mode) (both Rx IF and Tx data)
Front Panel	<ul style="list-style-type: none"> <li>• Vacuum Fluorescent Display (VFD): 2 lines @ 24 characters/line.</li> <li>• 6-button Keypad: ENT (Enter), CLR (Clear), (4X) navigation</li> <li>• LED system status display showing, for all modems: <ul style="list-style-type: none"> <li>○ Unit fault, Rx traffic fault</li> <li>○ Tx traffic alarm Online / Offline status</li> <li>○ Bridge status</li> </ul> </li> </ul>
Audible Alarm	Programmable to activate following various changes of state
Common faults	Dry relay contacts
Dimensional Envelope	19W x 11.75D x 6.75H inch (48.26W x 29.85D x 17.15H cm) (4RU)
Weight	~ 20 lbs (~ 9.07 kg)

## 1.5.2 Modem vs. Terrestrial User Data Interface Specifications

Modem	TMI	User Data Type	User Data Connector(s)
CDM-625A CDM-625	CRS-316	EIA-422, V.35	(1) DB-25F
		Single-port Ethernet Bridge Mode	(1) RJ45
	CRS-325	ASI	(2) BNCs
		G.703 Bal (DDI,IDO, DDO, IDI) G.703 Unbal (DDI, IDO)	(1) DB-15F (2) BNCs
	CRS-330	G.703 Bal (DDI,IDO, DDO, IDI) G.703 Unbal (DDI, IDO, DDO, IDI)	(1) DB-15F (4) BNCs
	CRS-336	HSSI	(1) HD-50F
		Single-port Ethernet Bridge Mode	(1) RJ45
	CRS-340	EIA-422, V.35, LVDS	(1) DB-25F
G.703 Bal (DDI,IDO, DDO, IDI) G.703 Unbal (DDI, IDO)		(1) DB-15F (2) BNCs	
CRS-365D	Quad E1 (1 to 4 Ports of E1)	(2) DB-9F	
CDM-570L/AL CDM-570/A	CRS-330	G.703 (Balanced/Unbalanced)	(1) DB-15F/ (2) BNC
	CRS-340	EIA-422, V.35, EIA-232	(1) DB-25F
G.703 (Balanced/Unbalanced)		(1) DB-15F/ (2) BNC	
SLM-5650A SLM-5650	CRS-316	MIL-STD-188-114, EIA-530	(1) DB-25F
		GigE	(1) RJ45
	CRS-325	G.703 Bal (DDI,IDO, DDO, IDI) G.703 Unbal (DDI, IDO)	(1) DB-15F (2) BNCs
		CRS-336	HSSI
Single-port Ethernet Bridge Mode	(1) RJ45		
CDM-Qx/QxL	CRS-316	EIA-530, V.35, EIA-232	(1) DB-25F
	CRS-325	G.703 Bal (DDI,IDO, DDO, IDI) G.703 Unbal (DDI, IDO)	(1) DB-15F (2) BNCs
		CRS-336	HSSI
	CRS-365	Quad E1 (1 to 4 Ports of E1)	(4) RJ45s
CDM-710G/710GL	CRS-325	G.703 Unbal	(2) BNCs
	CRS-336	HSSI	(1) HD-50F
GigE (one port only)		(1) RJ45	
CDM-710	CRS-325	ASI	(2) BNCs
	CRS-336	HSSI	(1) HD-50F
		GigE (one port only)	(1) RJ45
CDM-700	CRS-325	OC3 Copper	(2) BNCs
	CRS-336	HSSI	(1) HD-50F
		GigE (one port only)	(1) RJ45
CRS-345	Multi-Port Unbal G.703 (1-4 ports)	(8) BNCs	
CDM-600/L	CRS-330	G.703 Bal (DDI,IDO, DDO, IDI) G.703 Unbal (DDI, IDO, DDO, IDI)	(1) DB-15F (4) BNCs
	CRS-340	EIA-422, V.35,EIA-232, LVDS	(1) DB-25F
		G.703 Bal (DDI,IDO, DDO, IDI) G.703 Unbal (DDI, IDO)	(1) DB-15F (2) BNCs
	CRS-370	HSSI (User)	(1)HD-50F

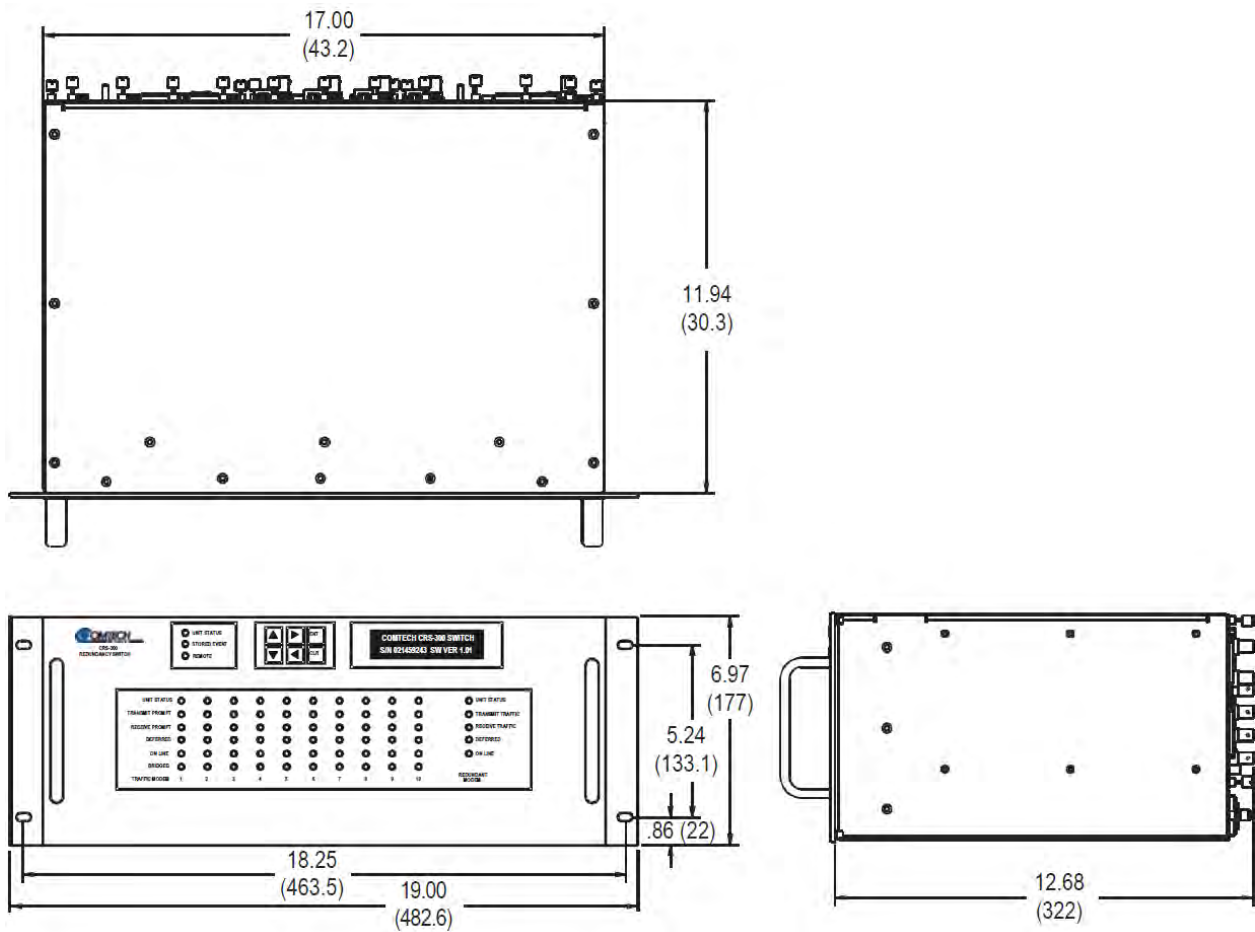
### 1.5.3 CRS-280 and CRS-280L IF Switch Specifications

Characteristic	Requirement	
	CRS-280 (70/140MHz)	CRS-280L (L-Band)
<b>Tx/Rx Operating Freq</b>	50 to 180 MHz	950 to 1950 MHz
<b>Tx / Rx Connectors</b>	BNC female	N-Type female (50Ω)
<b>Return Loss</b>	18 dB return loss into 75Ω (50Ω optional)	15 dB return loss into 50Ω
<b>Transmit IF Loss/Flatness</b> • Tx In To Tx Uplink Out • BU In To Any Uplink Out	< 1.5 dB over operating freq < 1.5 dB over operating freq	< 0.8 dB/0.5 dB over operating freq < 2.5 dB/1.0 dB over operating freq
<b>Receive IF Loss/Flatness</b> • Rx Downlink In To Rx Out • Any Downlink In To BU Out	< 5 dB over operating freq < 5 dB over operating freq	< 4.0 dB/0.5 dB over operating freq < 5.5 dB/1.0 dB over operating freq
<b>Tx to Tx Channel Isolation</b>	> 50 dB	> 70 dB
<b>Rx to Rx Channel Isolation</b>	> 50 dB	> 70 dB
<b>Tx to Rx Channel Isolation</b>	> 60 dB	> 90 dB
<b>Powering of IF Switch</b>	From the CRS-300 chassis	100 to 240 VAC 50/60 Hz (25W)
<b>Power Supply</b>	90-264 VAC, 50/60 Hz (25 W)	90-264 VAC
<b>Fuse</b>		
<b>Dimensional Envelope (Rack Mount 4RU)</b>	19W x 2.5D x 7H inches (48.26W x 6.35 x 18H cm)	
<b>Weight</b>	< 10 lbs (< 4.54 kg)	< 25 lbs (11.3 kg)

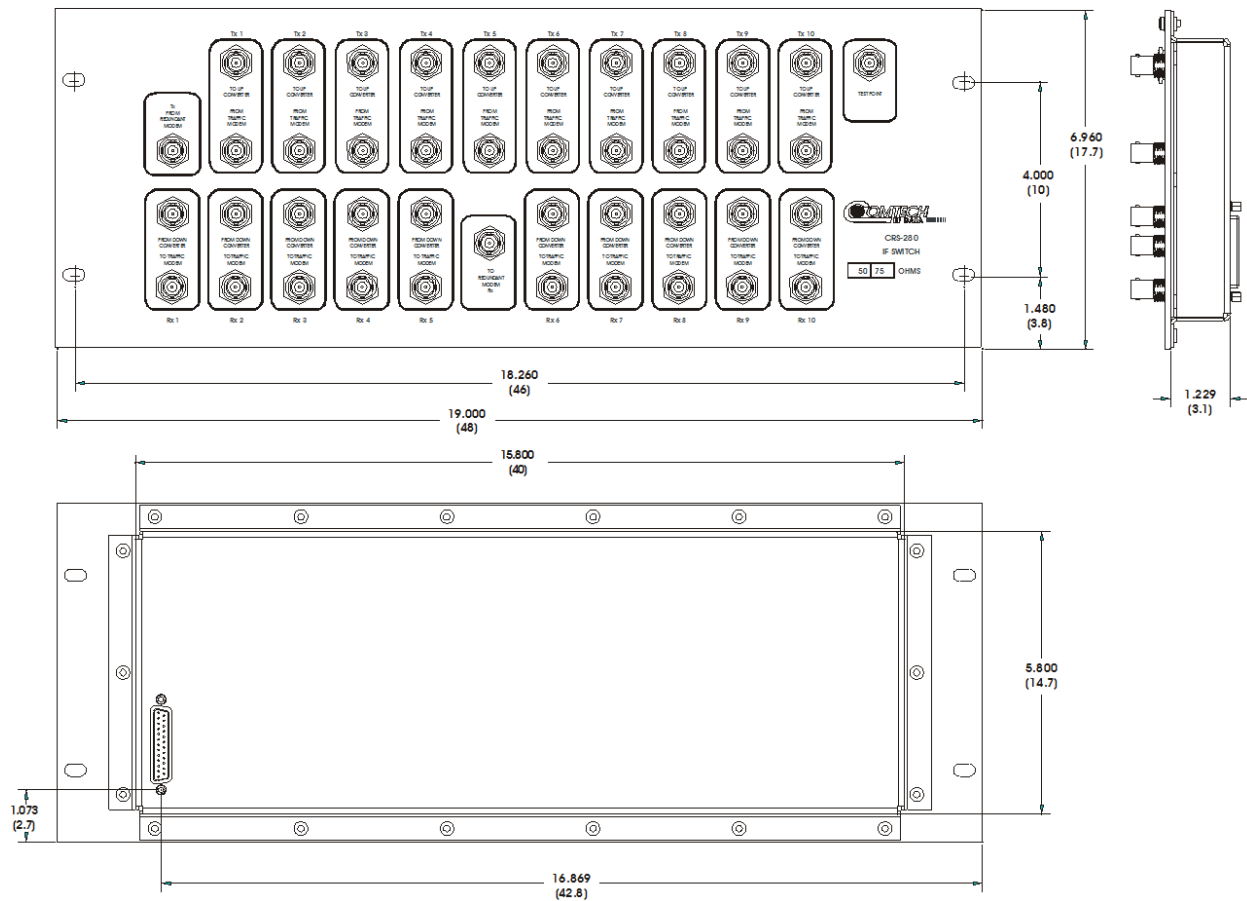
### 1.5.4 CRS-350 ESC Switch Specifications

Characteristic	Requirement
<b>User Data Interfaces</b>	(1) DB-25M Connector – ESC, overhead signals (1) DB-15F Connector – IDR Alarms (1) DB-9F Connector – Audio
<b>Power</b>	From CRS-300
<b>Dimensional Envelope (Rack Mount 4U)</b>	19W x 4.0D x 7H inches (48.26W x 27.5D x 18H cm)
<b>Weight</b>	5 lbs (2.2 kg)

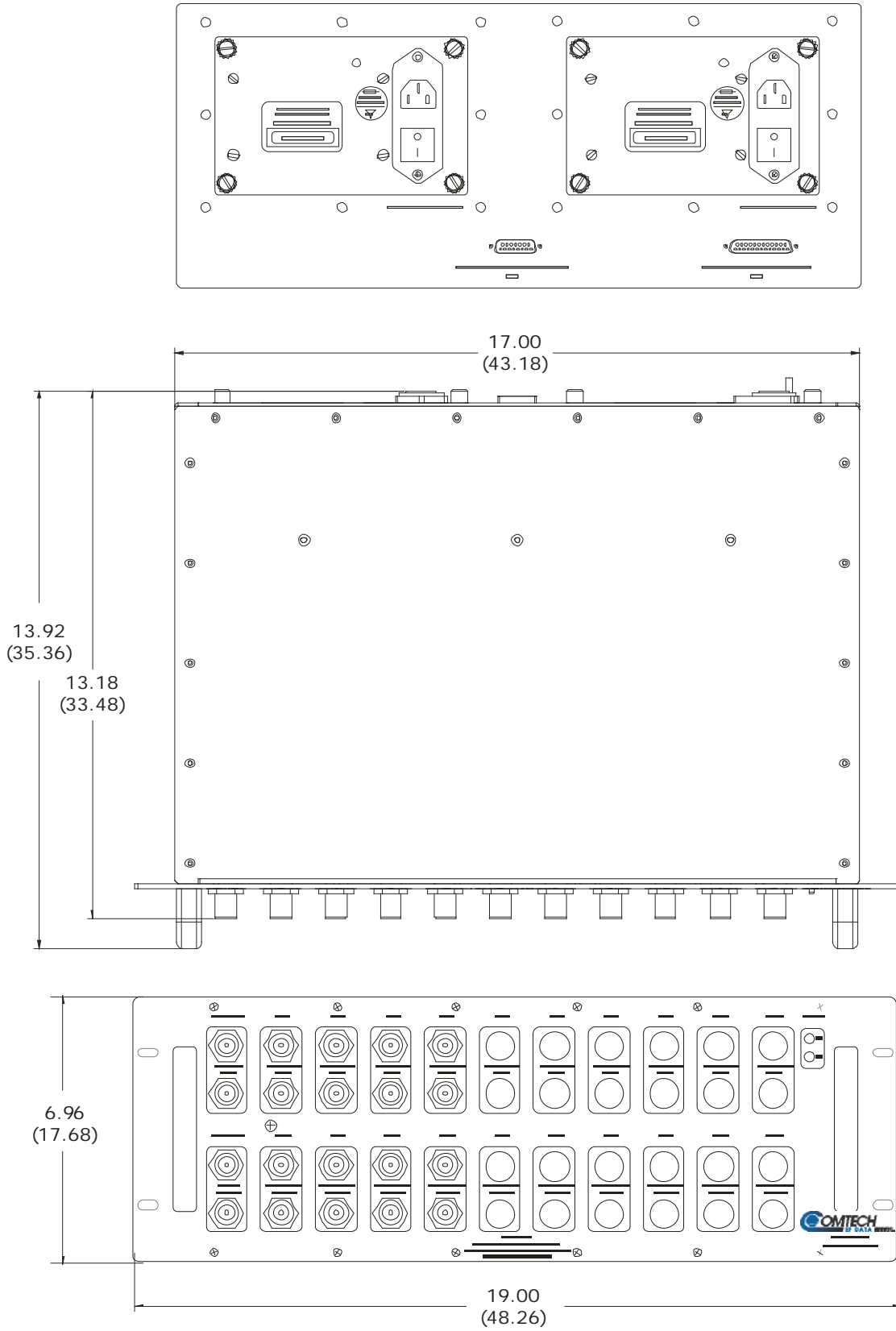
### 1.5.5 Dimensional Envelopes Details



**Figure 1-27. CRS-300 1:1 Redundancy Switch**

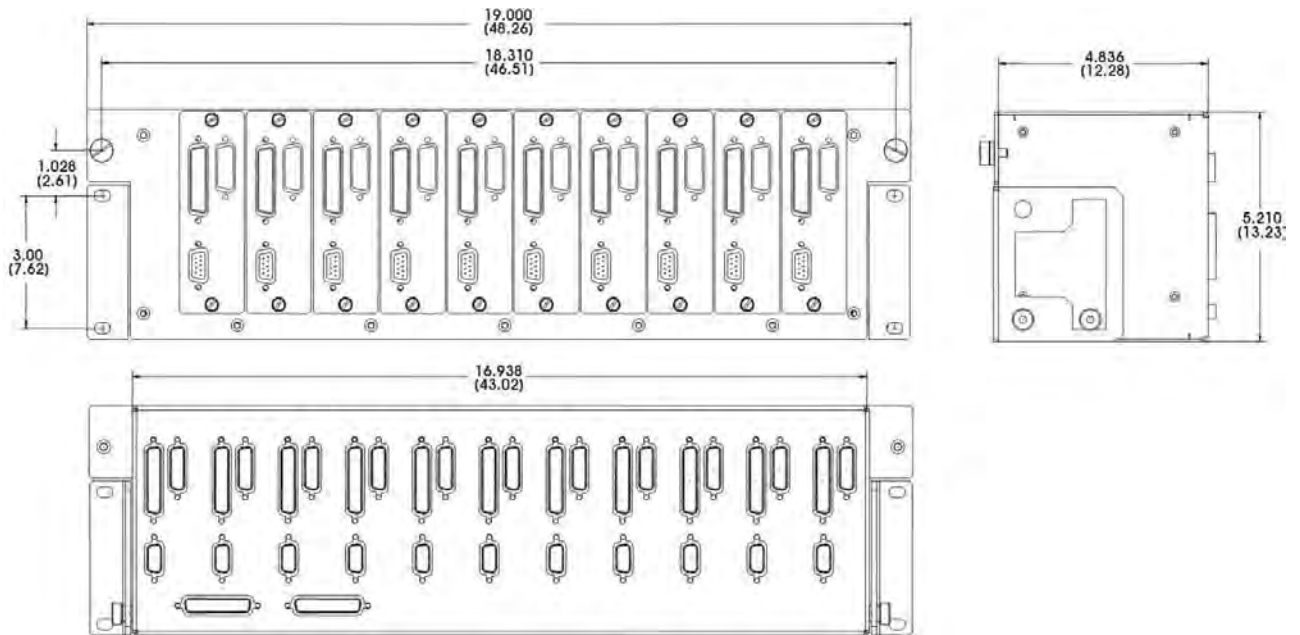


**Figure 1-28. CRS-280 (70/140 MHz) IF Switch**



**Figure 1-29. CRS-280L (L-Band) IF Switch**





**Figure 1-30. CRS-350 ESC Switch**



# Chapter 2. INSTALLATION

## 2.1 Unpack and Inspect the Shipment

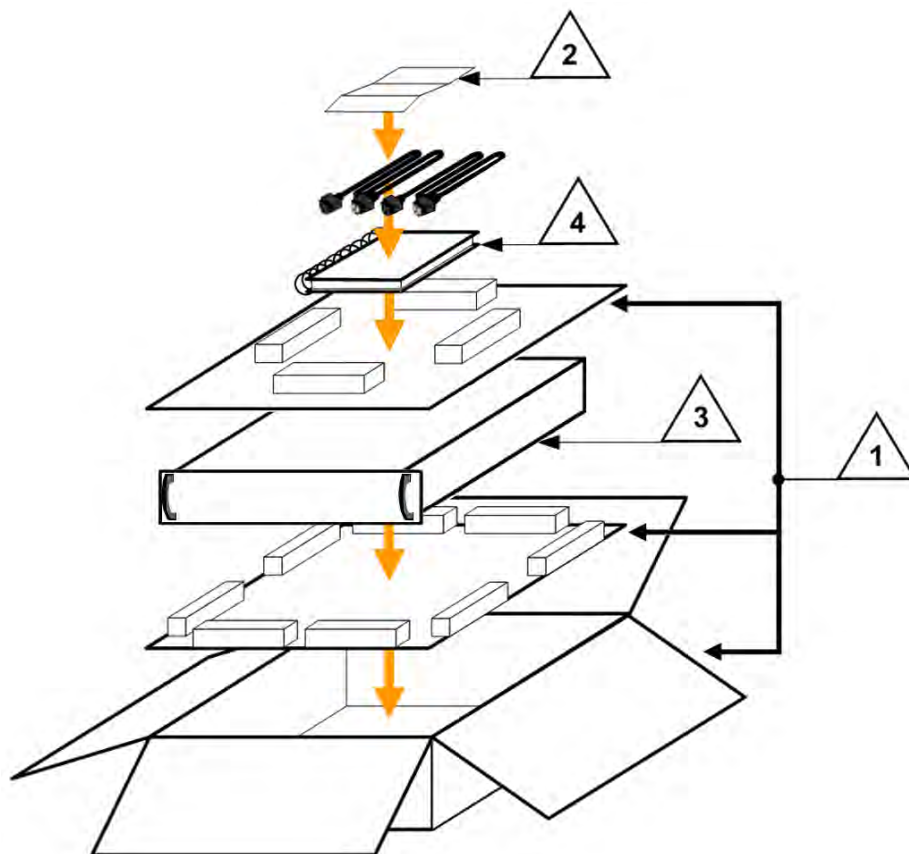


Figure 2-1. Unpacking and Inspecting the Shipment

The CRS-300 1:10 Redundancy Switch, its optional Installation and Operation Manual (otherwise available online at <http://www.comtechefdata.com>), and its power cords were packaged and shipped in a reusable cardboard carton containing protective foam spacing.



**CAUTION – THIS EQUIPMENT CONTAINS PARTS AND ASSEMBLIES SENSITIVE TO DAMAGE BY ELECTROSTATIC DISCHARGE (ESD). USE ESD PRECAUTIONARY PROCEDURES WHEN HANDLING THE EQUIPMENT.**



**Once opened, inspect the shipment:**

Step	Task
1	Keep all shipping materials.
2	Check the packing list to make sure the shipment is complete.
3	Inspect the equipment for damage. If damage exists, immediately contact the carrier and Comtech EF Data to submit a damage report.
4	Read the manual.

---

## 2.2 Install the Unit Into a Rack Enclosure

Mount the unit in its assigned position in the rack enclosure. Use, as required:

- A standard rack-mounted shelf, if needed;
- User-supplied fasteners to secure the products to the rack enclosure threaded front mounting rails.

**Figure 2-2** provides a “cut-away” side view of a typical rack configuration for modems combined with the CRS-300, optional CRS-280, and optional CRS-350:

- The CRS-300 is constructed as a 4RU-high, rack-mounting chassis. Handles on the Switch front panel facilitate placement and removal of the Switch into a rack.
- Mount all Switches and modems in the rack as necessary. Use the mounting holes on the product front panels to secure the primary equipment to the rack front mounting rails with your user-supplied fasteners.
- You can mount the CRS-280 IF Switch at the back or on top of the rack. If you use the CRS-280L, refer also to the associated *CRS-280L 1:N Redundancy Switch Installation and Operation Manual* (MN/CRS280L.IOM) for further rack mounting information.
- The CRS-350 mounts at the back of the rack. The CRS-350 mounting brackets allow you to hinge the unit down. This facilitates access to the interface connectors at the rear of the CRS-350, and makes cable connections easy between the CRS-350, CRS-300, and modems.



**CAUTION – When installing the equipment into a rack enclosure:**

- **PROPER GROUNDING PROTECTION IS REQUIRED.** The equipment must be connected to the protective earth connection at all times. It is therefore imperative that the unit is properly grounded, using the ground stud provided on the unit rear panels, during installation, configuration, and operation.

- **PROPER AIR VENTILATION IS REQUIRED.**
  - Air temperature inside the rack enclosure should **NEVER** exceed 50°C (122°F).
  - Since the Switch itself is relatively passive, no additional clearance is needed between it and the nearest modem.
  - The CRS-300 **CANNOT** have rack slides mounted to the sides of the chassis – air flow must not be impeded. Comtech EF Data recommends that an alternate method of support is provided within the rack, such as standard rack shelves, as needed.
  - Make sure there is adequate clearance inside the enclosure, especially at the sides, for air ventilation. In a rack system where there is high heat discharge, provide forced-air cooling with top- or bottom-mounted fans or blowers.

For information about custom rack enclosures, contact Comtech EF Data Product Support.

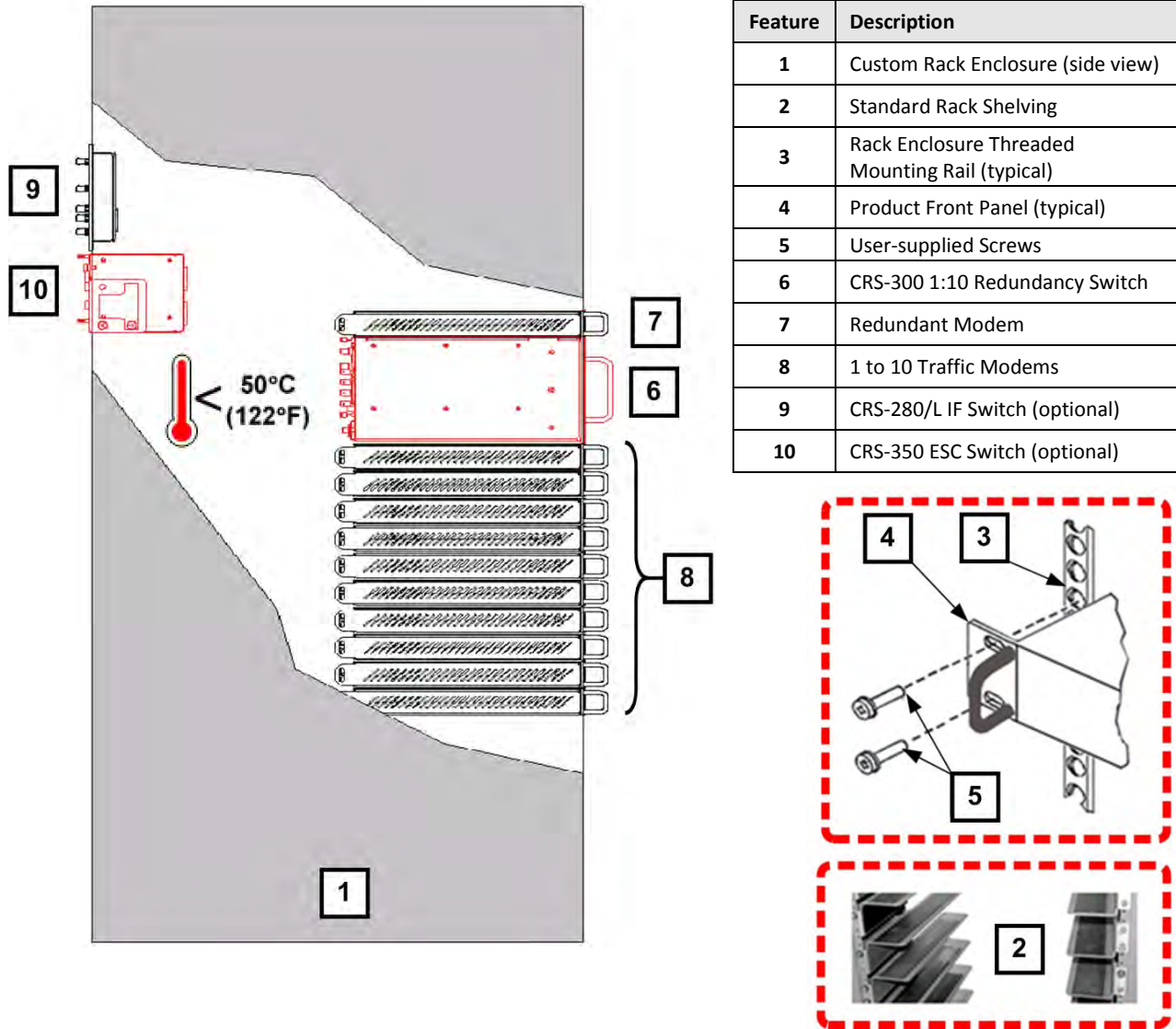


Figure 2-2. Typical Rack Mounting Configuration

# Chapter 3. SWITCH CONNECTORS AND PINOUTS

## 3.1 Cabling Connection Types

The cable and connector types described in this section are commonly used in many Comtech EF Data products. Each cable type is typically dedicated to a specific mode of operation.

The plug-in interface cards (including the CRS-230 System Controller card and a variety of Traffic Modem Interface (TMI) and Redundant Modem Interface (RMI) cards) that are available for use with the CRS-300 may not use all of these connector types.



**The European EMC Directive (EN55022, EN50082-1) requires that you use properly shielded cables for DATA I/O. These cables must be double-shielded from end-to-end, ensuring a continuous ground shield.**

### 3.1.1 Coaxial Cable Connections

Figure 3-1 show the coaxial cables (plugs) and their mating connectors (jacks/sockets) that Comtech EF Data uses with their products: 'BNC', 'TNC', 'N', 'F', and 'SMA'.





Coupling Type	Connector Type	
	Plug (Male)	Jack (Female)
Bayonet (Type 'BNC' shown)		
Threaded (Type 'N' shown)		

Figure 3-1. Coaxial Connector Examples

These connectors are available in two coupling styles: **Bayonet** or **Threaded**:

- **Bayonet Coupling Style** – The jack has a pair of guideposts that accommodate the plug’s lockdown slots. This lockdown design provides secure assembly without over-tightening the connection.
- **Threaded Coupling Style** – The jack features external threads. The plug shell features internal threads, and has either a knurled outer surface to permit hand-tightening of the connection, or hex flats to accommodate torqued installation.

**Connection Instructions:**

- **Bayonet Coupling Connections:** Use the plug slots to guide, then slide the plug onto the jack posts. Then, turn the plug clockwise until the jack posts are fully seated within the plug slot.
- **Threaded Coupling Connections:** Engage the plug onto the jack threads, and then turn the plug clockwise until it is fully threaded onto the jack. Do not over-tighten the connection.

---

### 3.1.1.1 Type ‘BNC’

BNC connectors feature a **Bayonet Coupling** design.



---

### 3.1.1.2 Type ‘TNC’

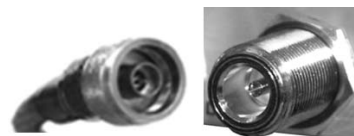
TNC connectors feature a **Threaded Coupling** design similar to Type ‘N’, Type ‘F,’ and Type ‘SMA’ connectors.



---

### 3.1.1.3 Type ‘N’

Type ‘N’ connectors feature a **Threaded Coupling** design similar to Type ‘TNC’, Type ‘F’, and Type ‘SMA’ connectors.



---

### 3.1.1.4 Type ‘F’

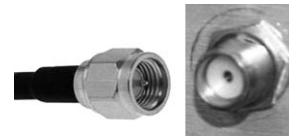
Type ‘F’ connectors feature a **Threaded Coupling** design similar to Type ‘TNC’, Type ‘N’, and Type ‘SMA’ connectors.





### 3.1.1.5 Type 'SMA' (Subminiature Version 'A')

Type 'SMA' connectors feature a **Threaded Coupling** design similar to Type 'TNC', Type 'N', and Type 'F' connectors.



### 3.1.2 D-Subminiature Cable Connections

Type 'D' Connection Type	Example
<p style="text-align: center;"><b>Chassis Receptacles: (TOP) Female (BOTTOM) Male</b></p>	
<p style="text-align: center;"><b>Type 'D' Cable With Jack Screws (Female Shown)</b></p>	

**Figure 3-2. D-Subminiature Connector Examples**

D-Subminiature connectors are also called **Type 'D'** or **'D-Sub'** connectors. The connector pair features multiple rows of pins (male side) coupled to mating sockets (female side). The cable plug and chassis receptacle each feature a D-shaped profile that interlock to ensure proper pin orientation and connector seating.

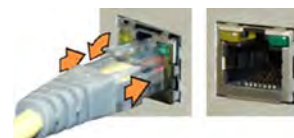
Either chassis receptacle gender features two jack nuts for secure assembly of the cable plug to the chassis receptacle.

Whether its gender is male or female, the cable plug features two jack screws for secure connection to the jack nuts provided on the mating chassis receptacle. The jack screws may be hand tightened or tightened with a standard flat-blade screwdriver.

**Connection Instructions:** Orient the plug to the receptacle in the proper position. Press firmly into place. Use the jack screws to secure the plug to the receptacle jack nuts. Do not over-tighten.

### 3.1.3 RJ-45, RJ-48 Cable Connections

The plug for an RJ-45 or RJ-48 cable features a flexible tab. The RJ-45 or RJ-48 jack features a mating slot. This design configuration assures proper installation and pin orientation.



**Connection Instructions:** Press down the tab on the cable plug, and then insert the plug into the RJ-4x jack. The connection is complete when the tab 'clicks' into position inside the jack.

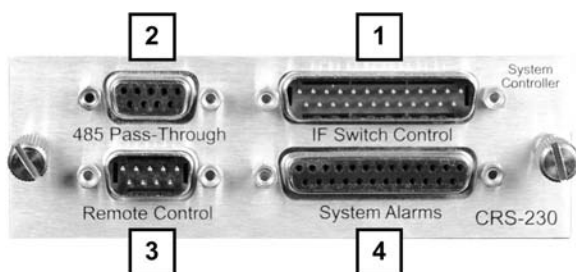
## 3.2 CRS-300 User Data Connectors



### Sect. 1.4.3 Plug-in Module (Card) Assemblies

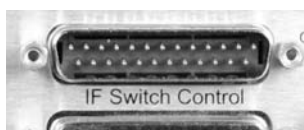
This section illustrates cabling connectors on the basis of available data or traffic interface type.

### 3.2.1 CRS-230 Controller Connectors



CRS-230 System Controller		
Feature	Connector Description	Chapter Sect
1	IF Switch Control	3.2.1.1
2	485 Pass-Through	3.2.1.2
3	Remote Control	3.2.1.3
4	System Alarms	3.2.1.4

#### 3.2.1.1 IF Switch Control Connector, DB-25M



Use the DB-25M IF Switch Control connector on the CRS-230 for direct connection to the corresponding cabling connector on the CRS-280 or CRS-350 switches, when used. This connector supplies power to these switches, provides the logic interface to drive the active modem, and decides whether the system is in bridged or backup mode. The CRS-280/350 performs the same bridging and backing up functions of the Tx and Rx IF signals identically to how the CRS-300 processes the terrestrial data signals.

#### 3.2.1.2 485 Pass-Through Connector, DB-9F



Use the DB-9F 485 Pass-Through connector on the CRS-230 only with CDM-Qx/QxL modems. It is provided for 2-Wire EIA-485 serial remote monitor and control of the modems.

**Table 3-1. 485 Pass-Through User Data Connector**

Pin	Signal Function	Direction
5	Ground	---
9	EIA-485 Transmit Data A	Out
4	Reserved - do not connect to this pin	---
8	EIA-485 Transmit Data B	Out
3	EIA-232 Receive Data	In
7	EIA-485 Receive Data A ( <b>see note</b> )	In
2	EIA-232 Transmit Data	Out
6	EIA-485 Receive Data B ( <b>see note</b> )	In
1	Ground	---

---

### 3.2.1.3 Remote Control Connector, DB-9M



The DB-9M Remote Control connector on the CRS-230 provides 2-Wire EIA-232 and EIA-485 serial remote monitor and control access to the Switch.

**Table 3-2. Remote Control Connector**

Pin	Signal Function	Direction
1	Ground	---
6	EIA-485 Receive Data B ( <b>see note</b> )	In
2	EIA-232 Transmit Data	Out
7	EIA-485 Receive Data A ( <b>see note</b> )	In
3	EIA-232 Receive Data	In
8	EIA-485 Transmit Data B	Out
4	Reserved - do not connect to this pin	---
9	EIA-485 Transmit Data A	Out
5	Ground	---

### 3.2.1.4 System Alarms Connector, DB-25F



See **Table 3-3** for the pinouts for the DB-25F “System Alarms” connector on the CRS-230.

**Table 3-3. System Alarms Connector**

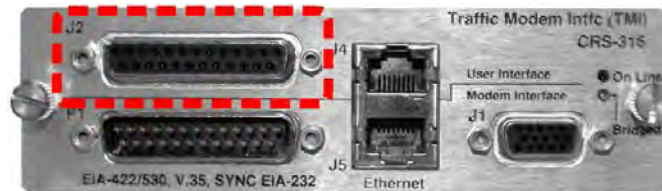
Signal Function by Mode of Operation		
Pin	“Show Fault” when Switch loses power (Default)	“Show No-Fault” when Switch loses power
13	Modem Summary DFM Fault – Normally Open	Modem Summary DFM Fault – Normally Closed
25	Modem Summary DFM Fault – Normally Closed	Modem Summary DFM Fault – Normally Open
12	Modem Summary Rx Traffic Fault – Normally Open	Modem Summary Rx Traffic Fault – Normally Closed
24	Modem Summary Rx Traffic Fault – Normally Closed	Modem Summary Rx Traffic Fault – Normally Open
11	Modem Summary Tx Traffic Fault – Normally Open	Modem Summary Tx Traffic Fault – Normally Closed
23	Modem Summary Tx Traffic Fault – Normally Closed	Modem Summary Tx Traffic Fault – Normally Open
10	Modem Summary Unit Fault – Normally Open	Modem Summary Unit Fault – Normally Closed
22	Modem Summary Unit Fault –Normally Closed	Modem Summary Unit Fault –Normally Open
9	Switch Unit Fault – Normally Open	Switch Unit Fault – Normally Closed
21	Switch Unit Fault – Normally Closed	Switch Unit Fault – Normally Open
8	Form ‘C’ Fault Relay – Common Common for pins 9-13 and 21-24	Unchanged
20	Audio Indicator (Ground = Auto On / Float = Audio Off)	
7	Ground	
19	No Connection	
6	Traffic Modem #1 Online Status – Normally Open (Note 2)	
18	Traffic Modem #2 Online Status – Normally Open (Note 2)	
5	Traffic Modem #3 Online Status – Normally Open (Note 2)	
17	Traffic Modem #4 Online Status – Normally Open (Note 2)	
4	Traffic Modem #5 Online Status – Normally Open (Note 2)	
16	Traffic Modem #6 Online Status – Normally Open (Note 2)	
3	Traffic Modem #7 Online Status – Normally Open (Note 2)	
15	Traffic Modem #8 Online Status – Normally Open (Note 2)	
2	Traffic Modem #9 Online Status – Normally Open (Note 2)	
14	Traffic Modem #10 Online Status – Normally Open (Note 2)	
1	Traffic Modem Online Status – Common Common for pins 2-6 and 14-18	

**Notes:**

- 1) “Normally open” refers to the NON-FAILED state.
- 2) Traffic Modem Online Status (Open = Online, Closed = Backup)

### 3.2.2 TMI User Data Connectors

#### 3.2.2.1 EIA-232/422/V.35 Connector, DB-25F (CRS-316)



See **Table 3-4** for the pinouts of the DB-25F EIA-232/422/V.35 User Data Interface connector – “J2” on the CRS-316 TMI.

**Table 3-4. EIA-232/422/V.35 Connector**

Pin	Generic Signal Function	Direction	Circuit No.	EIA-422/530	EIA-232	V.35
13	Note 2					
25	Note 2					
12	Internal Transmit Clock 'B'	Modem to DTE	114	ST B	---	SCT B
24	Transmit Clock 'A'	DTE to Modem	113	TT A	DA	SCTE A
11	Transmit Clock 'B'	DTE to Modem	113	TT B	---	SCTE B
23	Note 2					
10	Receiver Ready 'B'	Modem to DTE	109	RR	---	B
22	DCE Ready 'B'	Modem to DTE		DM_B		DM_B
9	Receive Clock 'B'	Modem to DTE	115	RT B	-	SCR B
21	Note 2					
8	Receiver Ready 'A'	Modem to DTE	109	RR A	CF	RLSD <sup>Note 1</sup>
20	Note 2					
7	Signal Ground	---	102	SG	AB	SG
19	Request to Send 'B' / Ready for Receiving 'B'	DTE to Modem		RS B		RS B
6	DCE Ready 'A'	Modem to DTE		DM_A		DM_A
18	Note 2					
5	Note 2					
17	Receive Clock 'A'	Modem to DTE	115	RT A	DD	SCR A
4	Request to Send 'A' / Ready for Receiving 'A'	DTE to Modem		RS A		RS A
16	Receive Data 'B'	Modem to DTE	104	RD B	---	RD B
3	Receive Data 'A'	Modem to DTE	104	RD A	BB	RD A
15	Internal Transmit Clock 'A'	Modem to DTE	114	ST A	---	SCT A
2	Transmit Data 'A'	DTE to Modem	103	SD A	BA	SD A
14	Transmit Data 'B'	DTE to Modem	103	SD B	---	SD B
1	Shield	---	101	Shield	AA	FG

**Notes:**

- 1) "Receiver Ready" is an EIA-232-level control signal on a V.35 interface.
- 2) Do NOT connect signals to these pins – they are reserved for use by the redundancy system.
- 3) 'B' signal lines are not used for EIA-232 applications.
- 4) For X.21 operation, use the EIA-422 pins, but ignore Receive Clock if the modem is DTE, and ignore Transmit clocks if the modem is DCE.

### 3.2.2.2 EIA-232/422/V.35/LVDS Connector, DB-25F (CRS-320/340)



Table 3-5 indicates the pinout for the DB-25F EIA-232/422/V.35/LVDS User Data Interface connector – “J1” on the CRS-320 TMI (obsolete), and “J2” on the CRS-340 TMI.

**Table 3-5. EIA-232/422/V.35/LVDS Connector**

Pin	Generic Signal Function	Direction	Circuit No.	EIA-232	EIA-422/530	V.35
13	Note 2					
25	Note 2					
12	Internal Transmit Clock 'B'	Modem to DTE	114	---	ST B	SCT B
24	Transmit Clock 'A'	DTE to Modem	113	DA	TT A	SCTE A
11	Transmit Clock 'B'	DTE to Modem	113	---	TT B	SCTE B
23	External Carrier Off (EIA-232 '1' or TTL 'low')	DTE to Modem	---	---	---	---
10	Receiver Ready 'B'	Modem to DTE	109	---	RR	B
22	Note 2					
9	Receive Clock 'B'	Modem to DTE	115	---	RT B	SCR B
21	Note 2					
8	Receiver Ready 'A'	Modem to DTE	109	CF	RR A	RLSD *
20	Note 2					
7	Signal Ground	---	102	AB	SG	SG
19	Note 2					
6	Note 2					
18	Note 2					
5	Note 2					
17	Receive Clock 'A'	Modem to DTE	115	DD	RT A	SCR A
4	Note 2					
16	Receive Data 'B'	Modem to DTE	104	---	RD B	RD B
3	Receive Data 'A'	Modem to DTE	104	BB	RD A	RD A
15	Internal Transmit Clock 'A'	Modem to DTE	114	DB	ST A	SCT A
2	Transmit Data 'A'	DTE to Modem	103	BA	SD A	SD A
14	Transmit Data 'B'	DTE to Modem	103	---	SD B	SD B
1	Shield	---	101	AA	Shield	FG

**Notes:**

- 1) "Receiver Ready" is an EIA-232-level control signal on a V.35 interface.
- 2) Do NOT connect signals to these pins – they are reserved for use by the redundancy system.
- 3) 'B' signal lines are not used for EIA-232 applications.
- 4) For X.21 operation, use the EIA-422 pins, but ignore Receive Clock if the modem is DTE, and ignore Transmit clocks if the modem is DCE.

### 3.2.2.3 ASI Connectors, BNC (CRS-325)



These BNC female connectors provide the Actuator Sensor Interface (ASI) User Data Interface on the CRS-325 TMI.

**Table 3-6. ASI Connectors**

BNC Connector	TMI CRS-325 Ref Des	Signal Function	Direction
Tx	J2	Tx, ASI	In
Rx	J4	Rx, ASI	Out

### 3.2.2.4 8 kHz IDR Connector, RJ-45F (CRS-330)

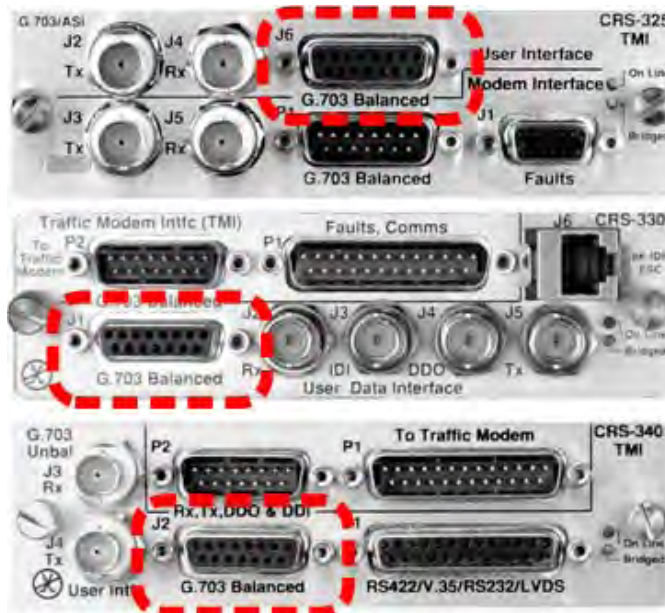


See **Table 3-7** for the RJ -45F connector pinouts. This port provides the EIA-422 clock and data for the 8 kHz IDR Engineering Service Channel (ESC) connector “J6” on the CRS-330 TMI.

**Table 3-7. 8 kHz – IDR ESC Connector**

Pin	Signal Function	Name	Direction
1	Tx Data+	SD+	In
2	Tx Data-	SD-	In
3	Rx Data+	RD+	Out
4	Tx Clock+	ST+	Out
5	Tx Clock-	ST-	Out
6	Rx Data-	RD-	Out
7	Rx Clock+	RT+	Out
8	Rx Clock-	RT-	Out

### 3.2.2.5 Balanced G.703 Connector, DB-15F (CRS-325/330/340)



See **Table 3-8** for the pinout for the DB-15F Balanced G.703 User Data Interface connectors – “**J6**” on the CRS-325 TMI; “**J1**” on the CRS-330 TMI; and “**J2**” on the CRS-340 TMI.

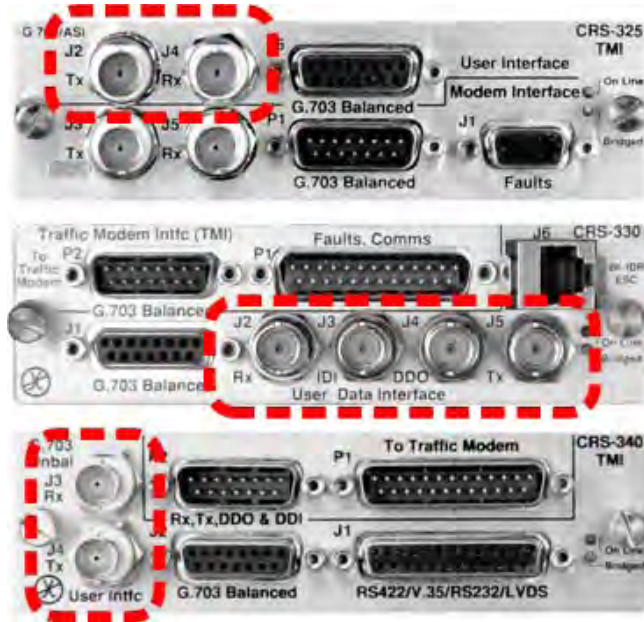
**Table 3-8. Balanced G.703 Connector**

Pin	Signal Function	Name	Direction
8	Not Used		
15	Not Used		
7	Not Used		
14	Not Used		
6	Insert Data Input (+)	IDI+	In
13	Insert Data Input (-)	IDI-	In
5	Drop Data Output (+)	DDO+	Out
12	Drop Data Output (-)	DDO-	Out
4	Ground	GND	
11*	Rx, Insert Data Output (+)	IDO+	Out
3*	Rx, Insert Data Output (-)	IDO-	Out
10	Not Used		
2	Ground	GND	
9*	Tx, Drop Data Input (+)	DDI+	In
1*	Tx, Drop Data Input (-)	DDI-	In

\* Use for all non-Drop and Insert and T2/E2 balanced applications.



### 3.2.2.6 Unbalanced G.703 Connectors, BNC (CRS-325/330/340)



These BNC female connectors provide the Unbalanced G.703 User Data Interface on the CRS-325, CRS-330, and CRS-340 TMIs.

**Table 3-9. Unbalanced G.703 Connectors**

BNC Connector	TMI CRS-325 Ref Des	TMI CRS-330 Ref Des	TMI CRS-340 Ref Des	Signal Function	Direction
Rx	J4	J2	J3	Rx (DDO), G.703	Out
Tx	J2	J5	J4	Tx (IDI), G.703	In
IDI	—	J3	—	Insert Data Input	In
DDO	—	J4	—	Drop Data Output	Out

### 3.2.2.7 Unbalanced G.703 4-Port Connectors, BNC (CRS-345)

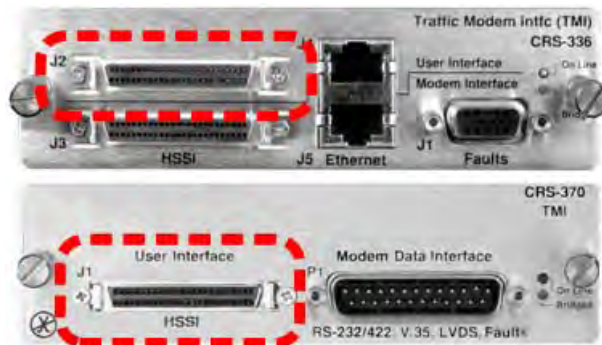


These BNC female connectors provide the Unbalanced G.703 User Data Interface on the CRS-345 TMI.

**Table 3-10. Unbalanced G.703 Connectors**

BNC Connector	Slot 1		Slot 2		Signal Function	Direction
	Port 1 Ref Des	Port 2 Ref Des	Port 1 Ref Des	Port 2 Ref Des		
Rx	J3	J5	J7	J9	G.703 Rx	Out
Tx	J4	J6	J8	J10	G.703 Tx	In

### 3.2.2.8 HSSI Connector, HD-50F (CRS-336/370)



See **Table 3-11** for the pinouts for the HD-50F SCSI-II (HSSI) User Data Interface connectors – “J2” on the CRS-336 TMI, and “J1” on the CRS-370 TMI.

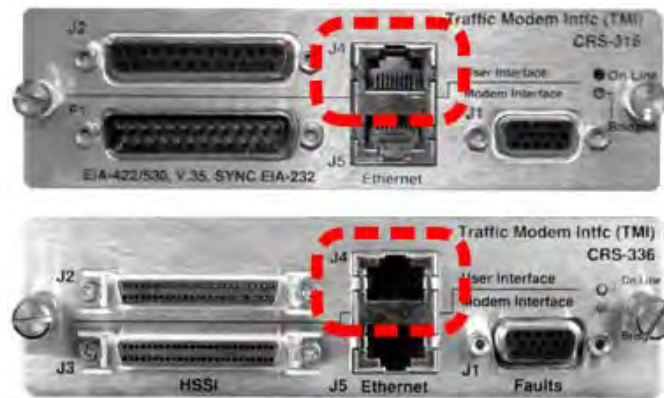
**Table 3-11. HSSI Connector**

Pin (+, -)	Signal Function	HSSI Signal	RS613 Circuit	Circuit Direction
1, 26	Signal Ground	SG	102	
2, 27	Receive Timing	RT	115	from DCE
3, 28	DCE Available	CA	107	from DCE
4, 29	Receive Data	RD	104	from DCE
5, 30	N/A	N/A	N/A	N/A
6, 31	Send Timing	ST	114	from DCE
7, 32	Signal Ground	SG	102	
8, 33	DTE Available	TA	108/2	to DCE
9, 34	Terminal Timing	TT	113	to DCE
10, 35	N/A	N/A	N/A	N/A
11, 36	Send Data	SD	103	to DCE
12, 37	N/A	N/A	N/A	N/A
13, 38	Signal Ground	SG	102	
14,15,17, 18, 39-43	Reserved (to DCE)			not used
16	Tx_Carrier_Off_L <sup>Notes 1, 3</sup>	CO	undefined	from DTE
19, 44	Signal Ground	SG	102	
20	Carrier Detect (lock) <sup>Notes 1, 2</sup>	CD	undefined	from DCE
21-24, 46-49	Reserved (to DTE)		undefined	not used
25, 50	Signal Ground	SG	102	

**Notes:**

- 1) Noted signal function names are non-HSSI defined signals. On Cisco™ routers, there is no connection to those pins.
- 2) TTL - output.
- 3) TTL or EIA-232 (active low) input.

### 3.2.2.9 10/100/1000 Gigabit Ethernet Connector, RJ-45F (CRS-316/336)

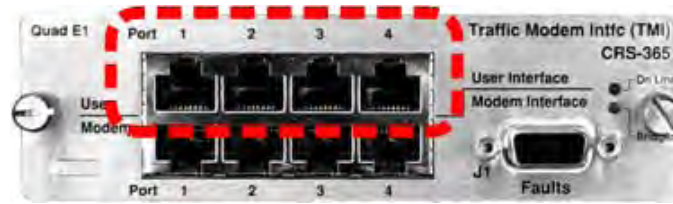


See **Table 3-12** for the RJ-45F connector pinouts for the 10/100/1000 Gigabit Ethernet User Data Interface (used for Ethernet Bridge Mode) connector – “J4” on the CRS-316 and CRS-336 TMIs.

**Table 3-12. 10/100/1000 Gigabit Ethernet Connector Pinouts**

Pin Pair	Pin
1	5
	4
2	1
	2
3	3
	6
4	7
	8

### 3.2.2.10 Quad E1 Connectors, RJ-48F (CRS-365)

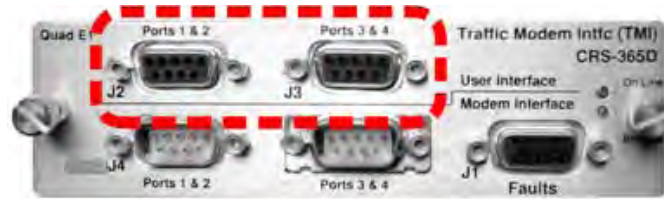


See **Table 3-13** for the RJ-48F connector pinouts for the Quad E1 User Data Interface – Ports **1** through **4** on the CRS-365 TMI.

**Table 3-13. Quad E1 Connector Pinouts (Typical Ports 1 through 4)**

Pin	Signal Function (where Port # = Port 1, 2, 3 or 4)	Direction
1	Port # Tx(+)	In
2	Port # Tx-	In
3	Ground	--
4	Port # Rx(+)	Out
5	Port # Rx-	Out
6	Ground	--
7	NC	--
8	NC	--

### 3.2.2.11 Quad E1 Connectors, DB-9F (CRS-365D)



See **Table 3-14** for the DB-9F connector pinouts for the Quad E1 User Data Interface connectors – “J2” and “J3” on the CRS-365D TMI.

**Table 3-14. Quad E1 Connector Pair Pinouts**

Pin	Signal Function Ref Des		Direction
	J2   Ports 1 & 2	J3   Ports 3 & 4	
5	Port 1 Tx(+)	Port 3 Tx(+)	In
9	Port 1 Tx(-)	Port 3 Tx(-)	In
4	Port 1 Rx(+)	Port 3 Rx(+)	Out
8	Port 1 Rx(-)	Port 3 Rx(-)	Out
3	Ground	Ground	---
7	Port 2 Tx(+)	Port 4 Tx(+)	In
2	Port 2 Tx(-)	Port 4 Tx(-)	In
6	Port 2 Rx(+)	Port 4 Rx(+)	Out
1	Port 2 Rx(-)	Port 4 Rx(-)	Out

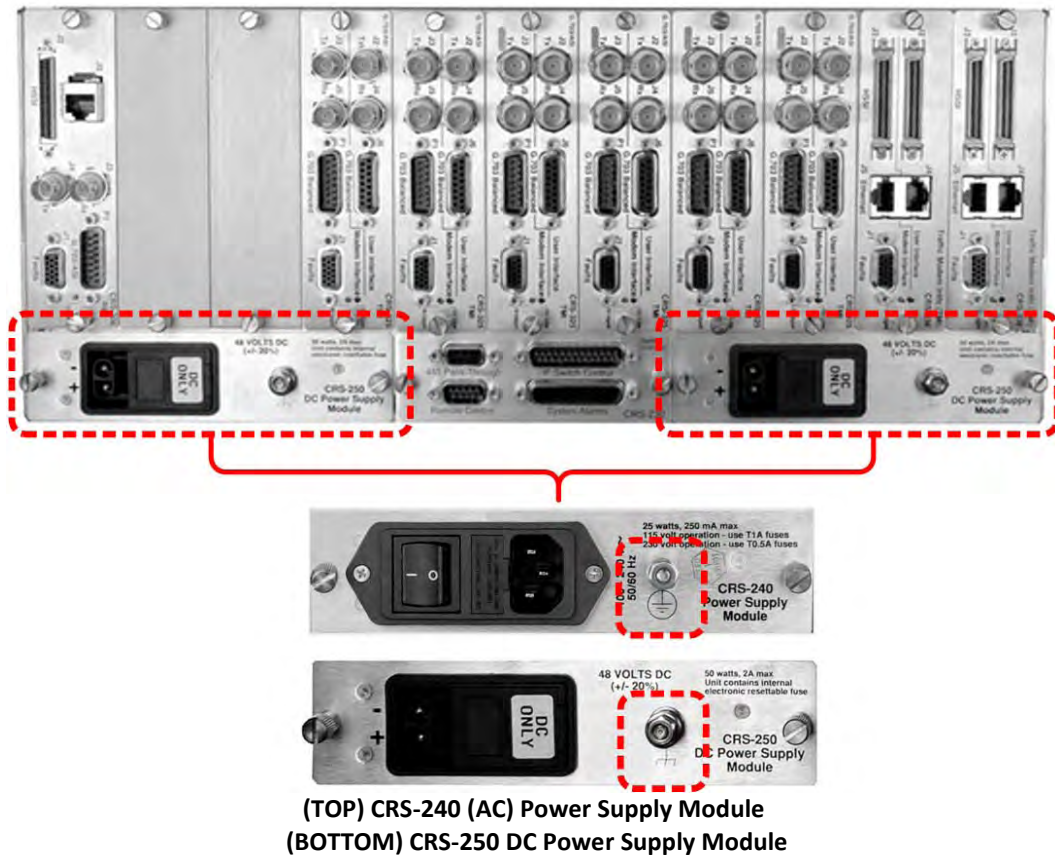
### 3.3 CRS-300 Chassis Ground and Power Connections

#### 3.3.1 Chassis Ground Interfaces



**CAUTION – PROPER GROUNDING PROTECTION IS REQUIRED. THE INSTALLATION INSTRUCTIONS REQUIRE THAT YOU MUST ENSURE THE INTEGRITY OF THE PROTECTIVE EARTH AND THAT YOU MUST MAINTAIN THE EQUIPMENT’S CONNECTION TO THE PROTECTIVE EARTH AT ALL TIMES.**

**THE CRS-300 IS DESIGNED FOR CONNECTION TO A POWER SYSTEM THAT HAS SEPARATE GROUND, LINE, AND NEUTRAL CONDUCTORS. THE EQUIPMENT IS NOT DESIGNED FOR CONNECTION TO A POWER SYSTEM THAT HAS NO DIRECT CONNECTION TO GROUND. IT IS THEREFORE IMPERATIVE DURING INSTALLATION, CONFIGURATION, AND OPERATION THAT YOU PROPERLY GROUND THE UNIT USING THE GROUND STUD PROVIDED ON THE REAR PANEL OF THE UNIT.**



**Figure 3-3. CRS-300 Chassis Ground Interfaces**

Use the #10-32 stud, located adjacent to the power interface on the CRS-230 or CRS-250 Power Supply Module (**Figure 3-1**), for connecting a common chassis ground among equipment.



**The AC power interface provides the safety ground.**

### 3.3.2 Chassis Power Interfaces

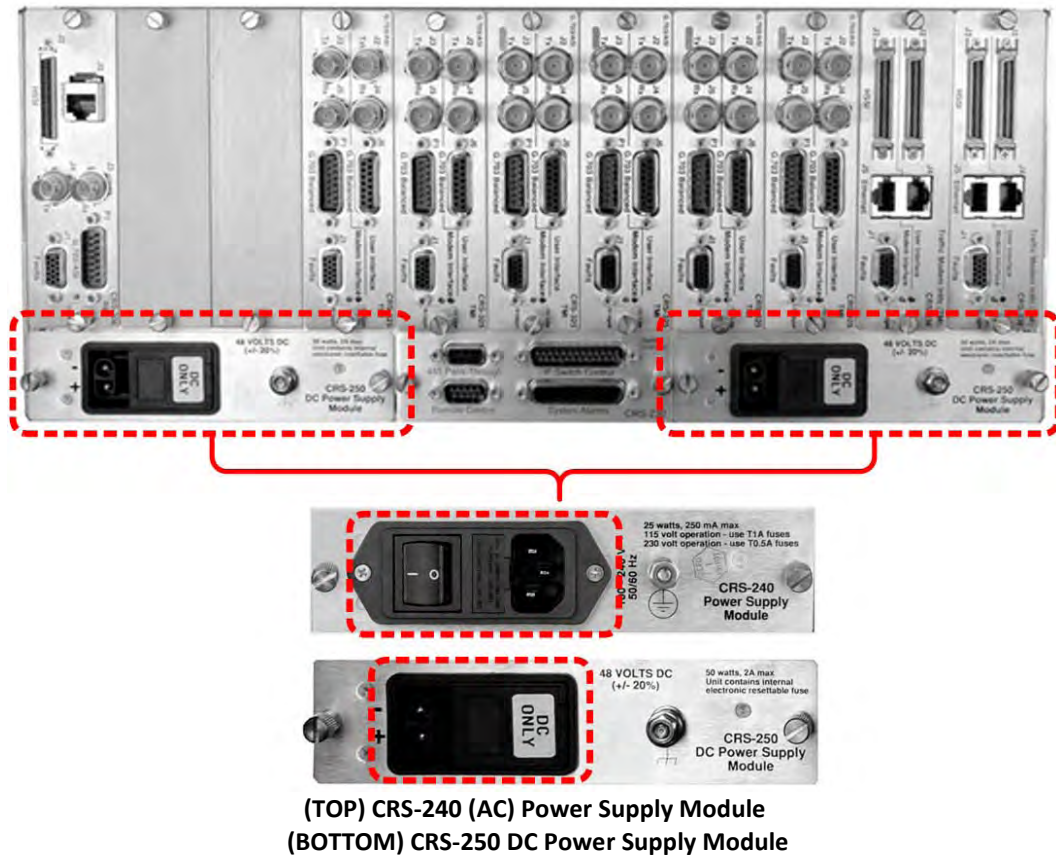


Figure 3-4. CRS-300 Chassis Power Supply Interfaces

#### 3.3.2.1 Alternating Current (AC) Power Interface



Feature	Description
1	On / Off Switch
2	Press-fit Fuse Holder
3	IEC-60320 Type C14 Three-prong Connector

AC Power Specifications	
Input Power	25W, 250 mA maximum
Input Voltage	90-264 volts AC (50/60 Hz)
Connection Type	IEC-60320 Type C13/C14
Fuse Protection	Line and neutral fusing (2X) 5mm x 20mm Slow-blow type fuses: <ul style="list-style-type: none"> <li>• 1.0A fuses for 115 volt AC operation</li> <li>• 0.5A fuses for 230 volt AC operation</li> </ul>

Figure 3-5. Chassis AC Power Interface (CRS-240 Power Supply Module)

### 3.3.2.1.1 AC Operation – Power Application



Figure 3-6. Apply AC Power

Apply AC power to the CRS-300 (Figure 3-6, typical for each module). Do these steps:

- **First**, plug the provided AC power cord female end into the unit.
- **Then**, plug the AC power cord male end into the user-supplied power source.
- **Finally**, switch the module ON.

### 3.3.2.1.2 AC Operation – Fuse Replacement

For AC operation, the Switch uses two *common* 5mm x 20mm Slow-blow fuses – one each for line and neutral connections. The fuses are contained within a fuse holder that is press-fit into the body of the IEC power module (Figure 3-7).

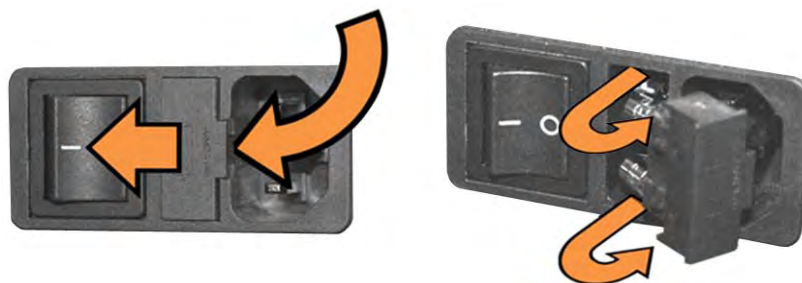



Figure 3-7. Replace the AC Fuses

Do these steps to replace the module fuse(s) (Figure 3-7, typical for each module):

 **WARNING! DISCONNECT THE POWER SUPPLY BEFORE PROCEEDING!**

- **First**, unseat the fuse holder from the IEC power module:
  - Use the slot to pry the holder outward from the IEC power module.



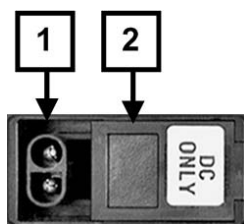
- Pull the holder straight out, and then swing the holder away from the module.
- **Then**, remove and replace the fuses as needed.



**CAUTION – FOR CONTINUED OPERATOR SAFETY, ALWAYS REPLACE THE FUSES WITH THE CORRECT TYPE AND RATING.**

- **Finally**, reseal the fuse holder in the IEC power module.

### 3.3.2.2 48V Direct Current (DC) Power Interface

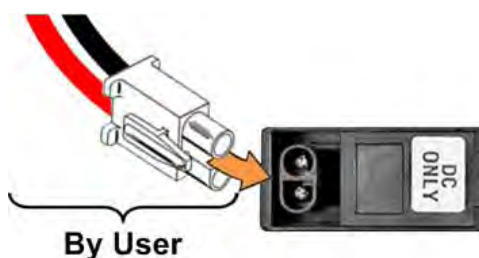


Feature	Description
1	Power Cord Connector
2	Press Fit Fuse Holder (NOT USED)

DC Power Specifications	
Input Power	50 watts, 2 Amps maximum
Input Voltage	48 volts DC ( $\pm 20\%$ ) nominal (38-60 volts)
Connector Type	Corcom PS series
Mating Connector	Corcom GA210 or Molex 03-12-1026
Fuse Protection	While this interface features a fuse holder that is press-fit into the body of the IEC power module, the CRS-300 chassis features an internal electronic resettable fuse.

**Figure 3-8. Chassis DC Power Interface (CRS-250 DC Power Supply Module)**

#### 3.3.2.2.1 48V DC Operation –Power Application



**Figure 3-9. Apply DC Power**

**To apply DC power to the CRS-300 (typical for each module):**

- First, plug the user-supplied, male keyed DC power lead connector into the mating female connector until the lock tab engages. **Number 18 AWG minimum wires are recommended.**
- Then, connect the user-supplied DC power leads to the power source.



# Chapter 4.

## CABLES AND CONNECTIONS

---

### 4.1 Overview



In order to avoid damage to both the Switch and the modems, it is important that you do these steps, in sequence:

- First, mount the Switch and all modems as instructed in [Chapter 2. INSTALLATION](#).
- Next, connect your control, IF, and traffic data cabling between the **powered OFF** modems and the Switch as instructed in this chapter. *Leave the Switch and all modems powered off until all connections are ready.*
- Then, configure your modems for 1:N redundant operation as instructed in [Sect. 5.2 Modem Configuration](#).
- Then, if needed, configure your Switch RMI/TMI cards as instructed in [Sect. 5.3 RMI Card Configuration Reference](#) and [Sect. 5.4 TMI Card Configuration Reference](#).
- Finally, once you have properly configured the modems and Switch RMI/TMI cards for 1:N redundant operation, you should then set the Switch for proper operation using the CRS-300 Front Panel, as instructed in [Sect. 5.5. Switch Configuration](#) in this chapter.

All cables required for the connection of control, IF, and traffic data between the CRS-300 1:10 Redundancy Switch and the modems, or within the system, are available from Comtech EF Data. You may contact Comtech EF Data Product Support to purchase any cables that are specified throughout this chapter.

If you use user-fabricated cables, the cables between each modem and Switch RMI or TMI plug-in module (interface card) should be of shielded, twisted-pair construction, with the grounded shield bonded to the back shell. You must wire all data cables correctly using the pinout and connection information that is provided in [Chapter 3. SWITCH CONNECTORS AND PINOUTS](#) or [Appendix B. CABLE DRAWINGS](#).

When you connect your cabling, in most cases the modem accepts the male end of the cable, while connectors on the Switch RMI or TMI plug-in card accept the female end of the cable in the section of the module labeled “Modem Interface.”



See the subsections in **Sect. 1.4 Description of CRS-300 Features** for detailed information on these interfaces.

The figures throughout this chapter provide cabling configuration examples for Switch RMI or TMI interfaces – i.e., the interconnection of a Redundant Modem to a Switch RMI module, or the interconnection between a Switch TMI module and a Traffic Modem.

See these chapter sections for step-by-step instructions to connect a variety of Switch and modem configurations:

- **Sect. 4.2 Switch-to-Switch Connections**
- **Sect. 4.3 IF Cable Connections**
- **Sect. 4.4 CDM-625/A Modem Connections**
- **Sect. 4.5 CDM-570/A, CDM-570L/AL Modem Connections**
- **Sect. 4.6 SLM-5650/5650A Modem Connections**
- **Sect. 4.7 CDM-Qx/QxL Modem Connections**
- **Sect. 4.8 CDM-710G/710GL Modem Connections**
- **Sect. 4.9 CDM-710 Modem Connections**
- **Sect. 4.10 CDM-700 Modem Connections**
- **Sect. 4.11 CDM-600/L Modem Connections**

## **4.2 Switch-to-Switch Connections**

- **CRS-300 to CRS-280/280L Connection**
- **CRS-300 to CRS-350 Connection**
- **CRS-300 to CRS-350 to CRS-280/280L Connection**

---

## 4.2 Switch-to-Switch Connections

If your redundancy system requires the Comtech EF Data CRS-280 (70/140 MHz) IF, CRS-280L (L-Band) IF, and/or CRS-350 Engineering Service Channel (ESC) Switch (for use only with the CDM-600/L, CDM-625/A, or SLM-5650/5650A modems), you need to use Control/Data Cable CA/WR0066 to connect the Switches. Comtech EF Data provides this cable with each CRS-280/280L and CRS-350 Switch.

The sections that follow explain the switch-to-switch cable connections that you must make between the CRS-300, CRS-350, and the CRS-280/280L.

### 4.2.1 CRS-300 to CRS-280/280L Connection

See **Figure 4-1** or **Figure 4-2** and do these steps to connect and secure the CA/WR0066 cable between the CRS-300 and the CRS-280/280L:

- DB-25M connector labeled “IF Switch Control” on the CRS-300’s CRS-230 System Controller, to
- DB-25F connector on the rear panel of the CRS-280/280L.

### 4.2.2 CRS-300 to CRS-350 Connection

See **Figure 4-3** and do these steps to connect and secure the CA/WR0066 cable between the CRS-300 and the CRS-350:

- DB-25M connector labeled “IF Switch Control” on the CRS-300’s CRS-230 System Controller, to
- DB-25F connector on the rear panel of the CRS-350.

### 4.2.3 CRS-300 to CRS-350 and CRS-280/280L Connection

See **Figure 4-4** or **Figure 4-5** and do these steps to first connect and secure the CA/WR0066 cable between the CRS-300 and CRS-350:

- DB-25M connector labeled “IF Switch Control” on the CRS-300’s CRS-230 System Controller, to
- DB-25F connector on the rear panel of the CRS-350.

**Next**, do these steps to connect and secure the second 25-pin CA/WR0066 cable between the CRS-350 and CRS-280/280L:

- DB-25M connector on the CRS-350, to
- DB-25F connector on the rear panel of the CRS-280/280L.



Figure 4-1. Control Cable Connection Example for CRS-300 to CRS-280

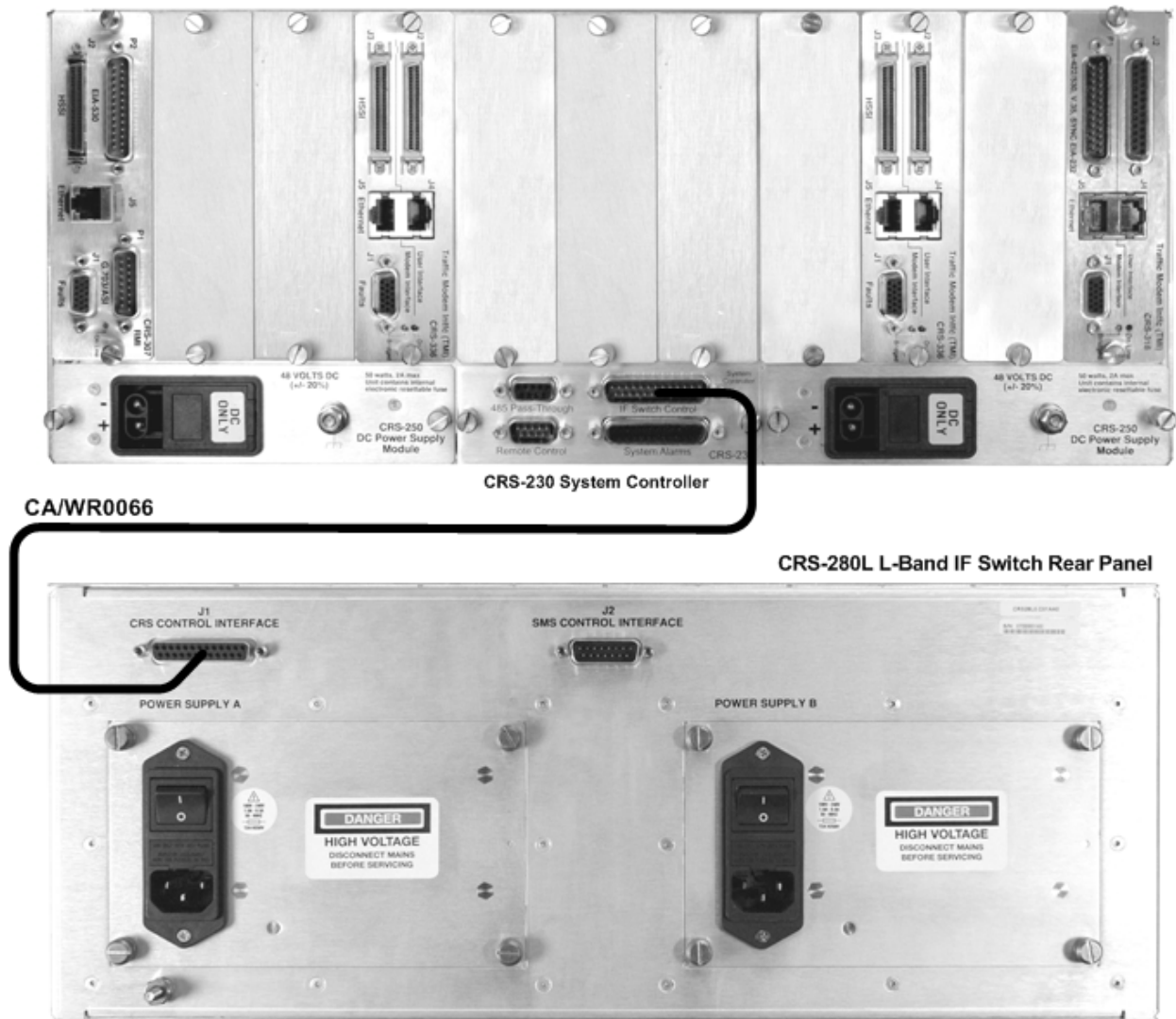


Figure 4-2. Control Cable Connection Example for CRS-300 to CRS-280L



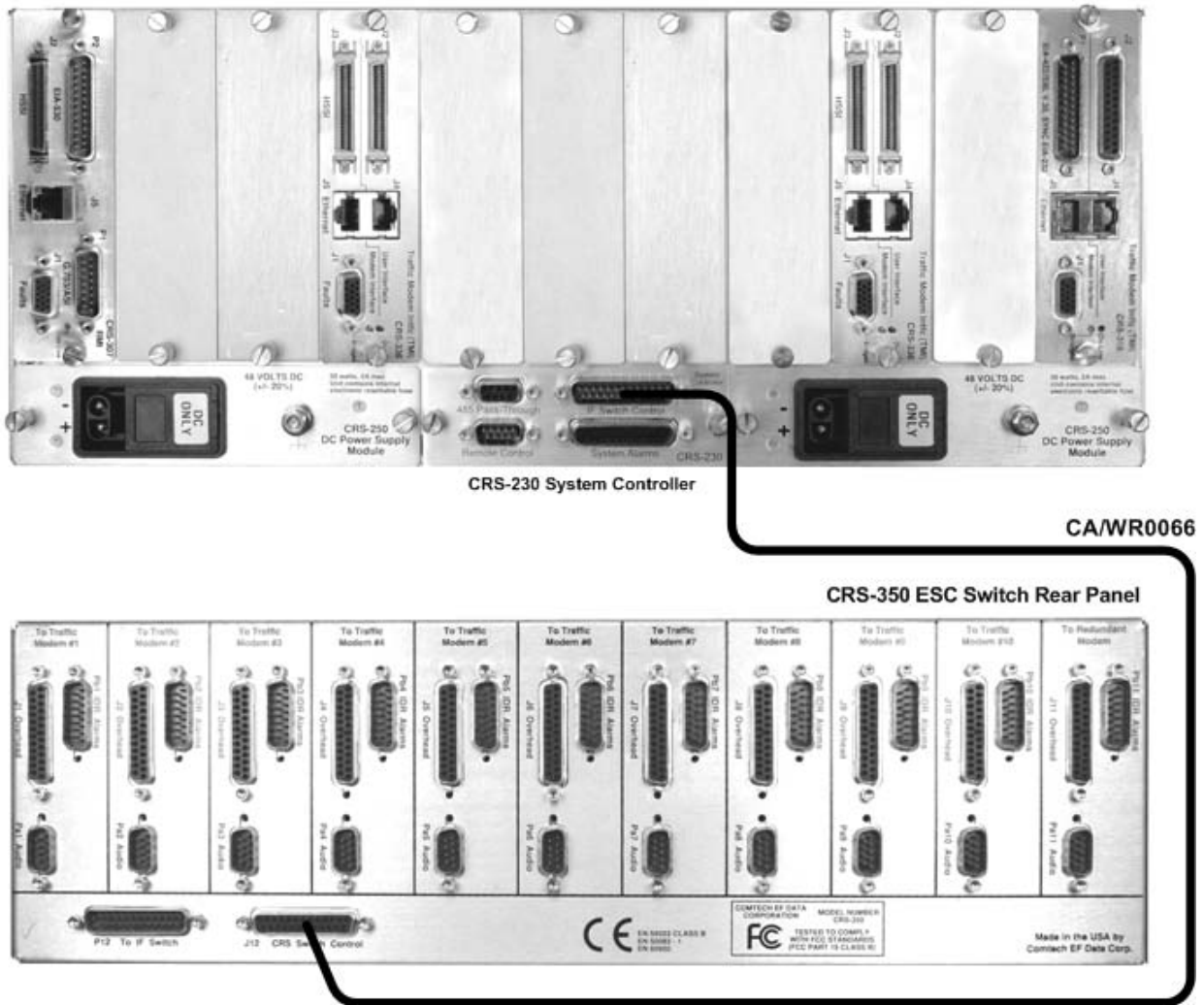


Figure 4-3. Control Cable Connection Example for CRS-300 to CRS-350

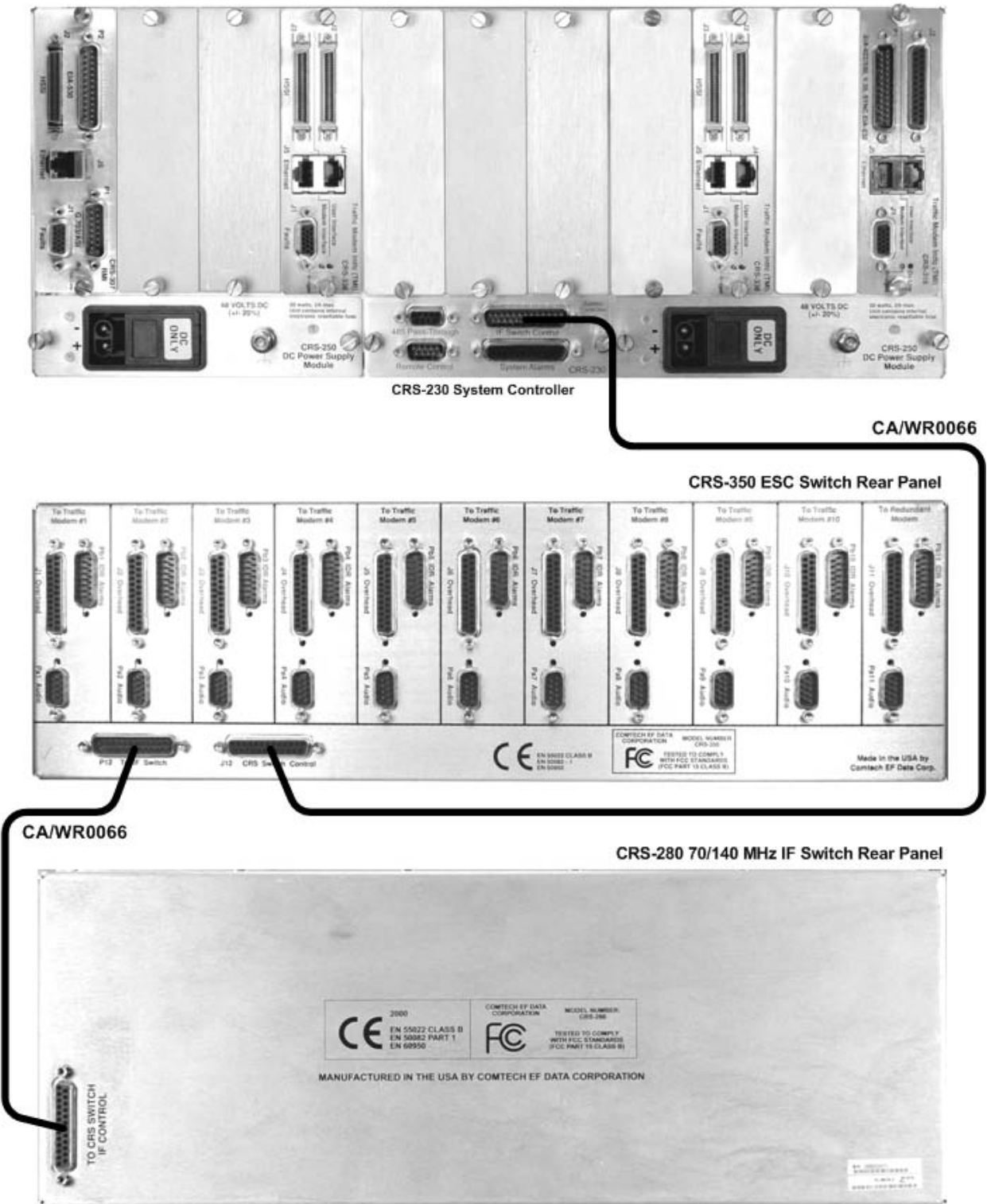


Figure 4-4. Control Cable Connection Example for CRS-300 to CRS-350 to CRS-280

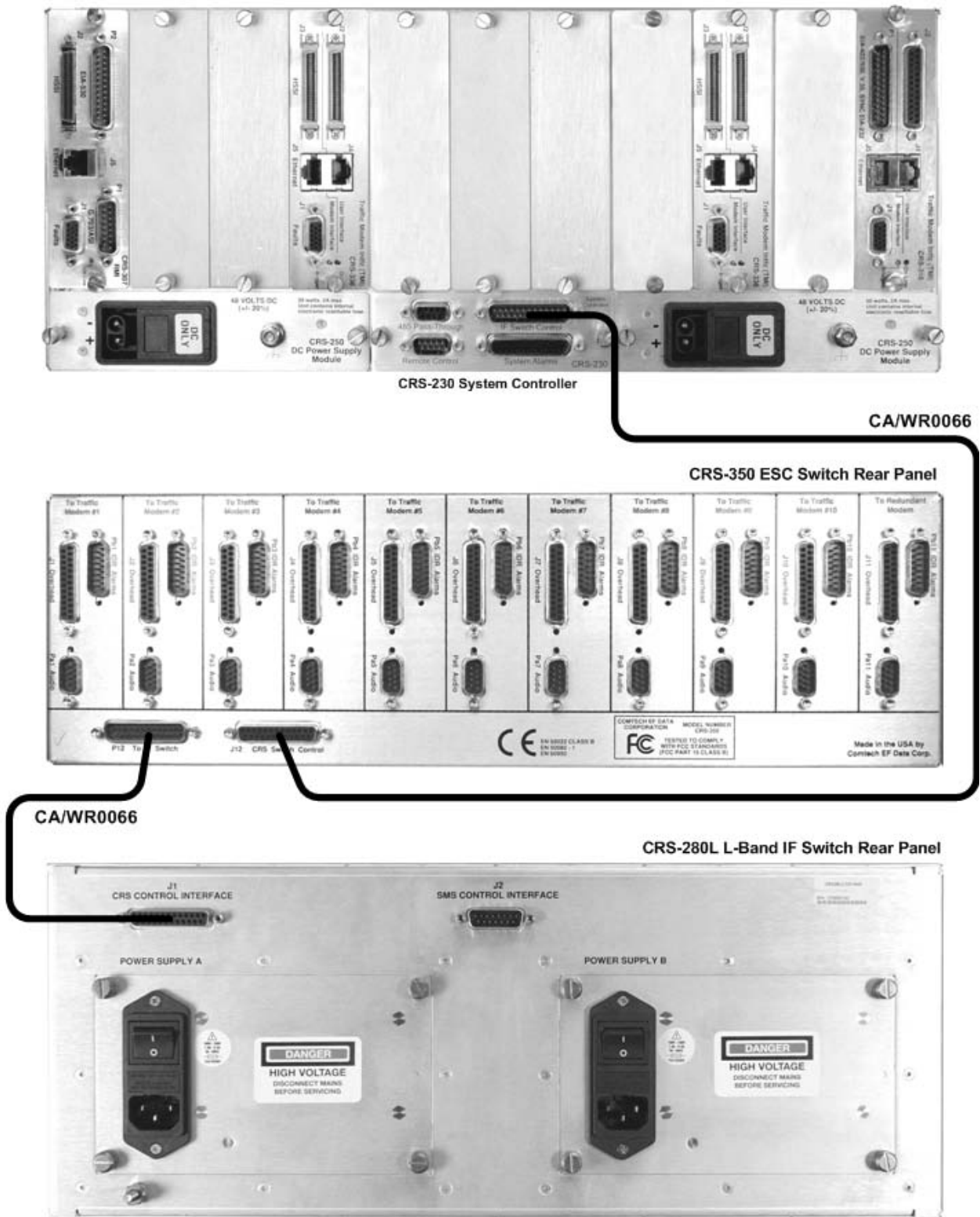


Figure 4-5. Control Cable Connection Example for CRS-300 to CRS-350 to CRS-280L



## **4.3 IF Cable Connections**

- **Single Transponder IF Connections**
- **Multiple Transponder IF Connections (Using IF Switch)**

---

## 4.3 IF Cable Connections

There are two different possible IF configurations:

- 1) **Single Transponder** – All modems are connected to the same user-provided Up/Downconverter.
- 2) **Multiple Transponders** – The modems may be grouped and connected in various combinations to multiple Up/Downconverters.

**You must use the CRS-280 (70/140 MHz) IF Switch for multiple transponder operation.**



**When you use the CRS-280L (L-Band) IF Switch, additional detailed installation information is provided in the CRS-280L 1:N Redundancy Switch Installation and Operation Manual (CEFD P/N MN/CRS280L.IOM)**

Proceed with the transponder configuration method applicable to your system.

### 4.3.1 IF Cable Connections – Single Transponder (without CRS-280/280L)



**To prevent problems resulting from impedance mismatch, you must make sure that the impedance for the modem's cables and combiner are the same.**

***Referring to Figure 4-6 (L-Band operation shown):***

For single transponder IF configurations, connect the user-provided IF cables:

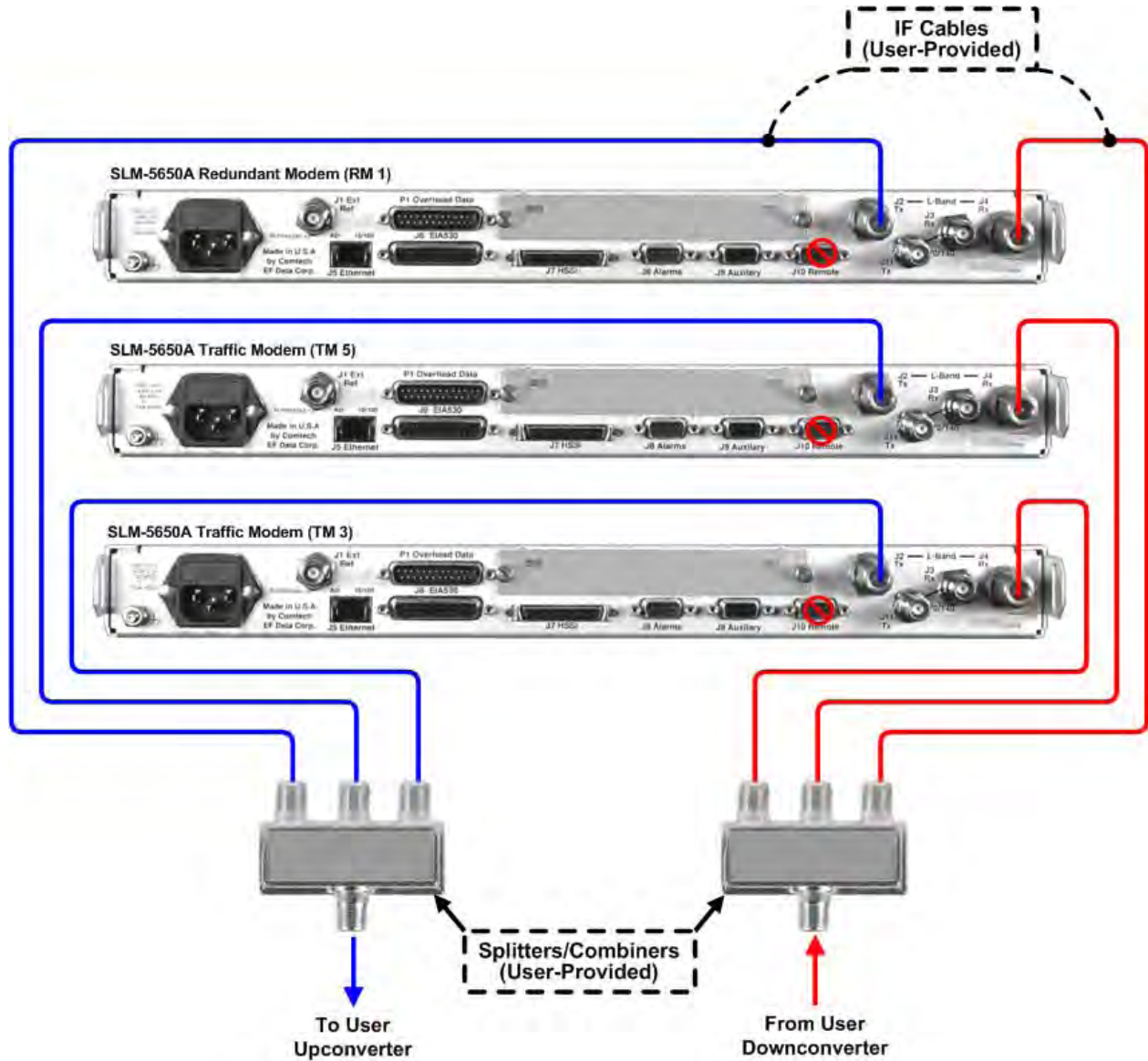
► **For Transmit (Tx) IF Connections, do these steps:**

- Connect the appropriate user-provided IF cables from each modem's "Tx IF" connector (BNC for 70/140 MHz, Type 'N' for L-Band) to a single user-provided power combiner.
- Connect the output of the power combiner to the user Upconverter.

► **For Receive (Rx) IF Connections, do these steps:**

- Connect the appropriate user-provided cables from each modem's "Rx IF" connector (BNC for 70/140 MHz, Type 'N' for L-Band) to the output ports of a single user-provided splitter.
- Connect the input of the splitter to the output of the user Downconverter.

When a modem is taken offline, its Tx IF is automatically muted (shut down) by the Switch.



**Figure 4-6. IF Cabling Example – Single Transponder Configuration**  
(Without CRS-280/280L – Connections shown for 1:N <1> RM with TMs 3 and 8 only)

### 4.3.2 IF Cable Connections – Multiple Transponder (Using IF Switch)

The CRS-280 IF (70/140 MHz) Switch provides complete isolation of the IF signals. The Redundant Modem's IF signals are routed to the Traffic Modem's IF path when the Switch RMI is online. The Switch automatically senses the presence of the CRS-280. The Switch, upon switching, leaves the offline modem with its IF on, and the CRS-280's relays isolate any undesired signals.

**Figure 4-7** provides a generic example of multiple transponder IF connections – in this instance, a 1:1 configuration using a CRS-280 IF Switch with CDM-600 modems. Using **PL/0946-2 (50Ω)** or **PL/0813-8 (75Ω)** BNC to BNC IF cables, observe the following for all modem/switch configurations:

#### **From the Redundant Modem:**

- Connect the "Rx IF" BNC connector on the Redundant Modem to the BNC connector on the CRS-280 switch labeled '**TO REDUNDANT MODEM Rx**'.
- Connect the "Tx IF" BNC connector on the redundant modem to the BNC connector on the CRS-280 switch labeled '**Tx FROM REDUNDANT MODEM**'.

#### **From the Tx Traffic Modems:**

- Connect the "Rx IF" BNC connector on each Traffic Modem to a BNC connector on the CRS-280 switch labeled '**Rx # (where Rx # designates Rx 1 through Rx 10) TO TRAFFIC MODEM**'.
- Connect the "Tx IF" BNC connector on each Traffic Modem to a BNC connector on the CRS-280 switch labeled '**Tx # (where Tx #designateis Tx 1 through Tx 10) FROM TRAFFIC MODEM**'.

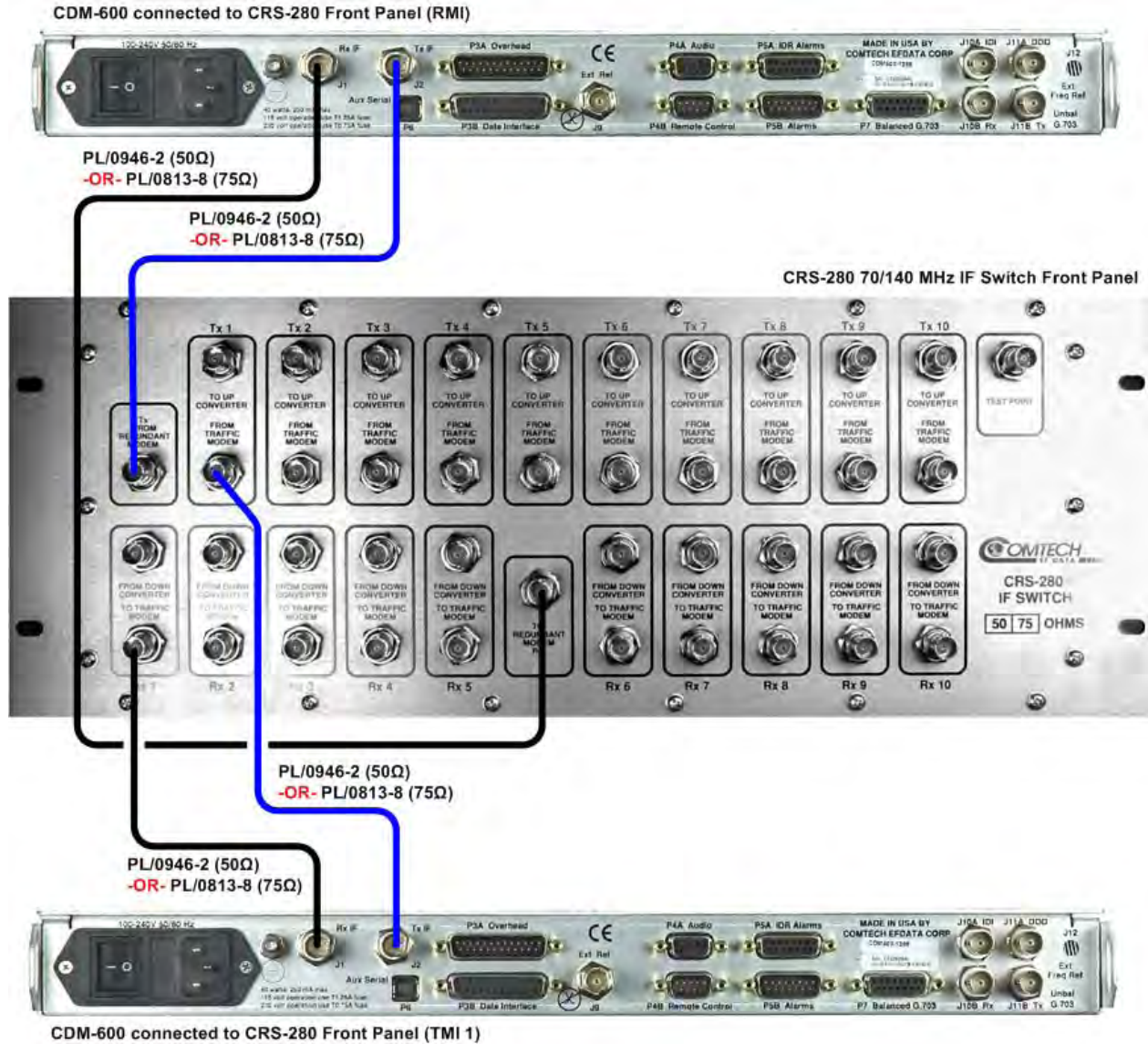


**When you use the CDM-Qx modem with the CRS-280 IF (70/140 MHz) Switch or the CDM-QxL modem with the CRS-280L (L-Band) Switch, use no more than one Mod / Demod per CDM-Qx/QxL chassis.**



**When you use the CRS-280L (L-Band) IF Switch, see the CRS-280L 1:N Redundancy Switch Installation and Operation Manual (CEFD P/N MN/CRS280L.IOM) for additional detailed installation information.**





**Figure 4-7. IF Cabling Example – Multiple Transponder Configuration  
(CRS-280 and CDM-600s shown, connections for RMI and TMI 1 only)**



## **4.4 CDM-625/A Modem Connections**

- **RMI/TMI Limitations and Considerations**
- **Carrier-in-Carrier® (CnC) Data Connections**
- **Control and Data Connections – CRS-300 to Modems**
- **Data Connections – CRS-300 to User**
- **Data Connections – CRS-350 Engineering Service Channel (ESC) Switch**
- **ESC Data Connections – CRS-350 to Modems**
  - **ESC Data Connections – CRS-350 to User**
  - **Using the CDM-625/A Modem in CDM-600 Emulator Mode**
- **Preparing the CDM-625/A for Operation in CDM-600/L Emulation Mode**
  - **Control and Data Connections – CRS-300 to Modems in CDM-600/L Emulation Mode**

---

## 4.4 CDM-625/A Modem Connections

If adding a modem to an **operating** 1:N system, care needs to be taken not to interfere with the existing traffic. The cabling and power-up sequence must be correct to avoid contention in the system from the modem Tx carrier. This sequence is described in **Sect. 6.2.2.5 CONFIG: ACTIVE (Activate Modems)**.

### 4.4.1 RMI/TMI Limitations and Considerations

With some exceptions, Traffic modems with differing data types can all be supported by the Redundant Modem.

See **Table 4-1** for the Switch RMI, TMIs, and cables that you will need to set up a proper redundant system configuration. As shown, and regardless of driving traffic data type, the CRS-300 1:10 Redundancy Switch uses the **CRS-310** Redundant Modem Interface (RMI) for all driving traffic configurations.

When you use the CDM-625/A in a CRS-300 1:10 Redundancy System, you may mix TMIs within the same Switch, with some limitations: **For example**, while you may use the “P2” (DB-15M) connector on the CRS-310 RMI for Balanced / Unbalanced G.703 or Quad E1 traffic, you may use **only one** of these two traffic data types within the Switch TMIs. Accordingly, for a Switch that uses any combination of the CRS-325, CRS-330, or CRS-340 TMIs for Balanced / Unbalanced G.703 traffic, you **may not** install the CRS-365D TMI (for Quad E1 traffic) in the same system.

See **Figure 4-9** through **Figure 4-11** for graphic examples of this operational dependency; each figure shows the Switch TMI types that you may use with the Traffic Modems.



**1) The Switch TMIs feature jumpers that are pre-set to ensure proper operation for the following traffic data:**

- For **EIA-422** with RTS/CTS, DTR/DSR signals using the CRS-316, CRS-320 (obsolete), or CRS-340
- For **HSSI** with CA/TA signals using the CRS-336

See **Chapter 5. MODEM, TMI, AND SWITCH CONFIGURATION** in this manual for this important configuration information.

**2) When you use the CDM-625/A in Dedicated Management Port mode, the modem disables all four of the offline modem’s Ethernet ports unless you configure one of the four ports as the ‘Dedicated Management Port.’**

For more information, see Sect. 5.4.13.3 CONFIG: IP → Setup in the CDM-625 or CDM-625A Advanced Satellite Modem Installation and Operation Manuals (CEFD P/Ns MN-CDM625 or MN-CDM625A).

## 4.4.2 Carrier-in-Carrier® (CnC) Data Connections

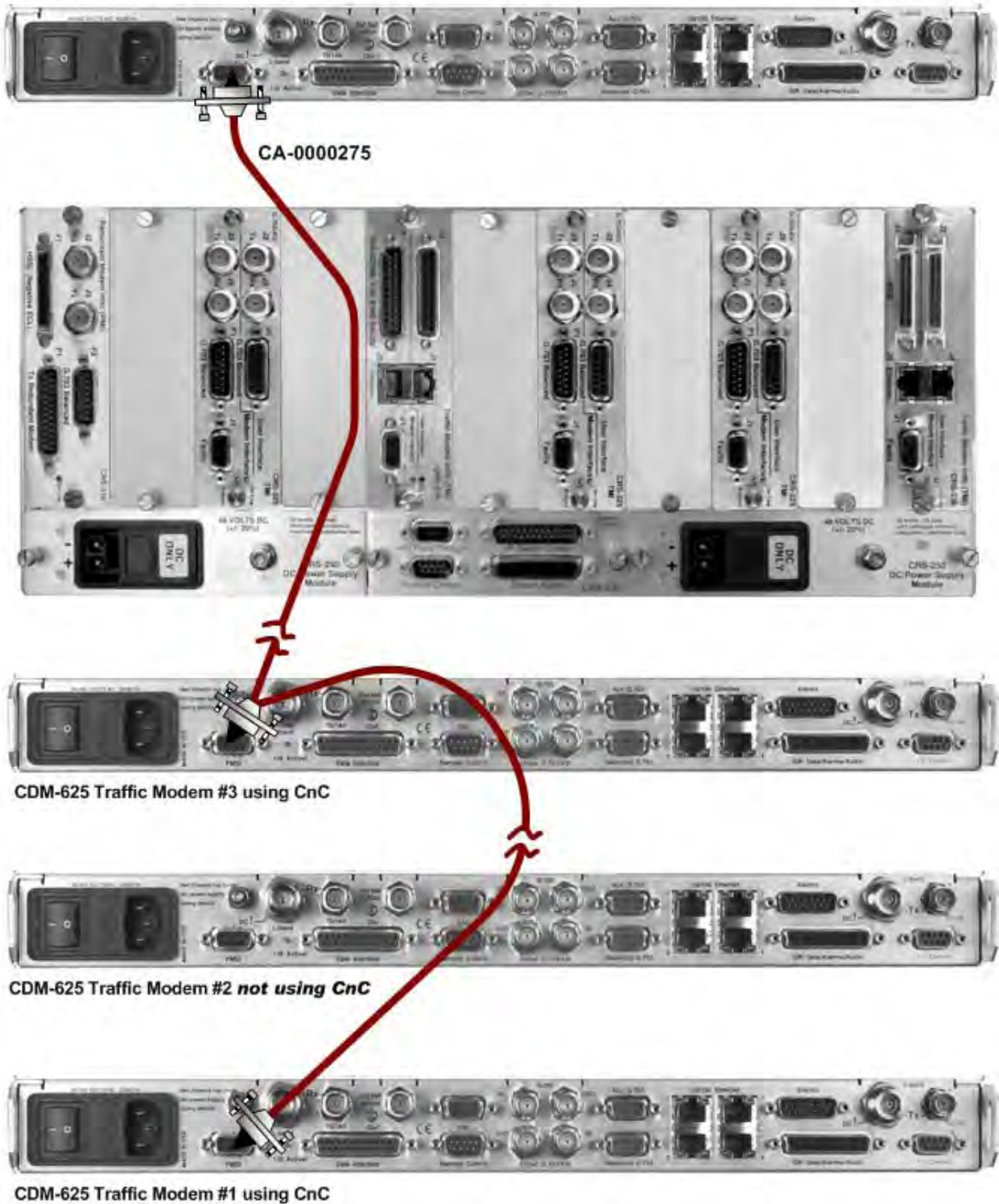


The CA-0000275 cable bypasses the CRS-300 1:10 Redundancy Switch.

If you use Carrier-in-Carrier® (CnC) with any Traffic CDM-625/A, see **Figure 4-8** and do these steps to connect and secure the PMSI Multi-drop CnC Plus Cable CA-0000275 (<11X> DB-9M, 8.25') between the Redundant CDM-625/A and any **CnC-enabled Traffic CDM-625/A(s)**:

- DB-9F connector labeled “PMSI” on the Redundant CDM-625/A, to
- DB-9F connectors labeled “PMSI” on all **CnC-enabled** Traffic CDM-625/A(s).

**CDM-625 Redundant Modem using CnC**



**Figure 4-8. CDM-625/A to CDM-625/A CnC® Cable Connection Example  
(Connections shown for Redundant Modem and Traffic Modems 1, 2, and 3 only)**

### 4.4.3 Control and Data Connections – CRS-300 to Modem

**Table 4-1** shows the TMI and applicable data and control cables that you will need for each of the various data types.

**Table 4-1. CDM-625/A Cable Usage (RMI/TMI)**

CDM-625/A Cable Usage (see Appendix B. CABLE DRAWINGS for cable details)				
Driving Traffic Data Type		CRS-310 RMI / Cable(s)	TMI / Cable(s)	
G.703 (Sect. 4.4.3.2)	Bal/Unbal	<b>Control:</b> CA/WR0066 <b>Data:</b> CA-0000072	CRS-330/340	<b>Control:</b> CA/WR0066 <b>Data:</b> CA-0000072
	Balanced	<b>Control:</b> CA/WR0066 <b>Data:</b> CA-0000072	CRS-325	<b>Control:</b> CA/WR0066 <b>Data:</b> CA-0000072
	Unbalanced	<b>Control:</b> CA/WR0066 <b>Data:</b> PL/0813-8 (2X)		<b>Control:</b> CA-0000069 <b>Data:</b> PL/0813-8 (2X)
G.703 – Quad E1 (Sect. 4.4.3.3)		<b>Control:</b> CA/WR0066 <b>Data:</b> CA-0000073	CRS-365D	<b>Control:</b> CA-0000069 <b>Data:</b> CA-0000136 (2X)
ASI (Sect. 4.4.3.4)		<b>Control:</b> CA/WR0066 <b>Data:</b> PL/0813-8 (2X)	CRS-325	<b>Control:</b> CA-0000069 <b>Data:</b> PL/0813-8 (2X)
EIA-422 (Sect. 4.4.3.5)		<b>Control/Data:</b> CA/WR0066	CRS-316	<b>Control:</b> CA-0000069 <b>Data:</b> CA/WR0066
			CRS-340	<b>Control:</b> CA/WR0066 <b>Data:</b>
HSSI (Sect. 4.4.3.6)		<b>Control/Data:</b> CA/WR0066	CRS-336	<b>Control:</b> CA-0000069 <b>Data:</b> CA/WR9189-6 <i>with</i> CIC-60 Adapter Module
LVDS (Sect. 4.4.3.7)		<b>Control/Data:</b> CA/WR0066	CRS-340	<b>Control/Data:</b> CA/WR0066
Ethernet (Sect. 4.4.3.8)	Wired-thru (No Sub-Mux) (Sect. 4.4.3.8.1)	<b>Control:</b> CA/WR0066 <b>Data:</b> CA-0000121	CRS-316 or CRS-336	<b>Control:</b> CA-0000069 <b>Data:</b> PP/CAT5FF7FTGY
	Wired-around (Sub-Mux) (Sect. 4.4.3.8.2)	<b>Control:</b> CA/WR0066 <b>Data (by User):</b> CAT5 to 10/100/1000 Switch	N/A	N/A

#### 4.4.3.1 Control Cabling Requirement (Regardless of Driving Traffic Data Type)

**For RMI connections:** The Control/Data Cable CA/WR0066 (DB-25F to DB-25M, 6') provides the serial communication path between the Redundant CDM-625/A and the Switch (via the CRS-310 RMI) for all driving traffic data types. **You must always use this cable.**

**For all driving traffic data types,** see **Figure 4-9** through **Figure 4-11** and do these steps to connect and secure the CA/WR0066 cable between the Redundant CDM-625/A and the Switch CRS-310 RMI:

- DB-25F connector labeled “Data Interface” on Redundant CDM-625/A, to
- DB-25M connector labeled “P1” on the Switch CRS-310 RMI.

**For TMI connections:** Depending on the driving data traffic type, in addition to its use as a control cable between the Redundant CDM-625/A and the CRS-310 RMI, you may use the

CA/WR0066 cable as: a control cable between the Traffic CDM-625/A(s) and the CRS-330 or CRS-340 TMI; as a data cable with the CRS-316 TMI; and as a combination control/data cable for use with the CRS-340 TMI.

For specific details regarding the CA/WR0066 cable's use as a TMI control and/or data cable, see the data connection cabling instructions that follow for each driving traffic data type.

Additionally, when you use the CRS-316, CRS-325, or CRS-336 TMI, you must use the CA-0000069 (HD-15M to DB-9M, 6') Control Cable between the installed TMI(s) and Traffic CDM-625/A(s).

See **Table 4-1** in **Sect. 4.4.3**, and read the data connection cabling instructions that follow, for use of this cable with the pertinent driving traffic data type.

### 4.4.3.2 G.703 Balanced / Unbalanced Data Connections

If **G.703 (Balanced/Unbalanced)** is the driving traffic data type, your means of interconnection depends on which Switch TMI is in use. **Figure 4-9** depicts use of the **CRS-330** and **CRS-340** TMIs for G.703, while **Figure 4-10** depicts use of the **CRS-325** TMI for G.703.



**G.703 traffic TMIs are not compatible with the CRS-365D Quad E1 traffic TMI when you use both TMIs within the same Switch.**

Make all connections according to the information that follows:

► **If you use the CRS-330 or CRS-340 TMIs (as shown in Figure 4-9), do these steps:**

**First**, connect the Control/Data Cable CA/WR0066 (for control purposes) between the Redundant CDM-625/A and the Switch RMI (see **Sect. 4.4.3.1**).

**Next**, do these steps to connect and secure the Control/Data Cable CA/WR0066 (for control purposes) between the Switch TMI(s) and Traffic CDM-625/A(s):

- DB-25M connector labeled "P1" on the Switch TMI(s), to
- DB-25F connector labeled "Data Interface" on the Traffic CDM-625/A(s).

**Finally**, do these steps to connect and secure the Data Cable CA-0000072 (DB-15F to DB-9M, 6'). Use these cables for Balanced or Unbalanced G.703 data between the Switch RMI or TMI(s) and the Redundant and Traffic CDM-625/A(s):

- DB-15M connector labeled "P2" on the Switch RMI or TMI(s), to
- DB-9F connector labeled "Balanced G.703" on the Redundant and Traffic CDM-625/A(s).

► **If you use the CRS-325 TMI (as shown in Figure 4-10), do these steps:**

Specific cabling requirements apply for operation with the CDM-625/A.



**First**, do these steps to connect the Control/Data Cable CA/WR0066 (for control purposes) between the Redundant CDM-625/A and the Switch RMI (see **Sect. 4.4.3.1**).

**Next**, do these steps to connect and secure the Data Cable CA-0000072 (DB-15F to DB-9M, 6'), between the Redundant CDM-625/A and Switch RMI:

- DB-9F connector labeled "Balanced G.703" on the Redundant CDM-625/A, to
- DB-15M connector labeled "P2" on the Switch RMI.

**Then**, do these steps to connect and secure the Control Cable CA-0000069 (HD-15M to DB-9M, 6') between the Switch TMI(s) and Traffic CDM-625/A(s):

- HD-15F connector labeled "J1" on the Switch TMI(s), to
- DB-9F connector labeled "1:1 Control" on the Traffic CDM-625/A(s).

**Finally**, for **Balanced G.703 data only**, do these steps to connect and secure the Data Cable CA-0000072 (DB-15F to DB-9M, 6') between the Switch TMI(s) and Traffic CDM-625/A(s):

- DB-15M connector labeled "P2" on the Switch TMI(s), to
- DB-9F connector labeled "Balanced G.703" on the Traffic CDM-625/A(s).

**–or–**

For **Unbalanced G.703 data only**, do these steps to connect and secure the pair of PL/0813-8 cables (75Ω BNC to BNC, 8'):

- BNC connector labeled "J3 Tx" on the Switch TMI(s) to BNC connector labeled "Unbal G.703/ASI – IN" on the Traffic CDM-625/As, and
- BNC connector labeled "J5 Rx" on the Switch TMI(s) to BNC connector labeled "Unbal G.703/ASI – OUT" on the Traffic CDM-625/A(s).

### 4.4.3.3 G.703 Quad E1 Data Connections

**If Quad E1 is the driving traffic data type (see Figure 4-11 and Figure 4-12), do these steps:**

**First**, connect the Control/Data Cable CA/WR0066 (for control purposes) between the Switch RMI and the Redundant CDM-625/A (see **Sect. 4.4.3.1**).

**Next**, do these steps to connect and secure the Data 'Y' Cable CA-0000073 (DB-15F to <2X> DB-9M, 6') between the Switch RMI and the Redundant CDM-625/A:

- DB-15M connector labeled "P2" on the Switch RMI, to

- DB-9F connector labeled “Balanced G.703” on the Redundant CDM-625/A (using “P3” connector on cable),

**–and–**

- DB-9F connector labeled “Aux G.703” on the Redundant CDM-625/A (using “P2” connector on cable).

**Then**, do these steps to connect and secure the Control Cable CA-0000069 (HD-15M to DB-9M, 6') between the Switch CRS-365D TMI(s) and Traffic CDM-625/A(s):

- HD-15F connector labeled “J1” on the Switch TMI(s), to
- DB-9F connector labeled “1:1 Control” on the Traffic CDM-625/A(s).

**Finally**, do these steps to connect and secure a pair of Data Cables CA-0000136 (DB-9F to DB-9M, 6'):

- DB-9M connector labeled “P1” on the Switch TMI(s), to
- DB-9F connector labeled “Aux G.703” on the Traffic CDM-625/A(s),

**–and–**

- DB-9M connector labeled “P2” on the Switch TMI(s), to
- DB-9F connector labeled “Balanced G.703” on the Traffic CDM-625/A(s).

#### 4.4.3.4 ASI Data Connections

**If ASI is the driving traffic data type (see Figure 4-9 through Figure 4-11), do these steps:**

**First**, connect the Control/Data Cable CA/WR0066 (for control purposes) between the Switch RMI and the Redundant CDM-625/A (see **Sect. 4.4.3.1**).

**Next**, do these steps to connect and secure a pair of PL/0813-8 cables (75Ω BNC to BNC, 8'), for data purposes, between the Switch RMIs and the Redundant CDM-625/A:

- BNC connector labeled “J3 Tx” on the Switch RMI to BNC connector labeled “Unbal G.703/ASI – IN” on the Redundant CDM-625/A, and
- BNC connector labeled “J2 Rx” on the Switch RMI to BNC connector labeled “Unbal G.703/ASI – OUT” on the Redundant CDM-625/A.

**Then**, do these steps to connect and secure a pair of PL/0813-8 cables (75Ω BNC to BNC, 8') between the CRS-325 TMI(s) and the Traffic CDM-625/A(s):

- BNC connector labeled “J3 Tx” on the Switch TMI(s), to BNC connector labeled “Unbal G.703/ASI – IN” on the Traffic CDM-625/A(s), and
- BNC connector labeled “J5 Rx” on the Switch TMI(s) to BNC connector labeled “Unbal G.703/ASI – OUT” on the Traffic CDM-625/A(s).

**Finally**, do these steps to connect and secure the Control Cable CA-0000069 (HD-15M to DB-9M, 6') between the Switch CRS-325 TMI(s) and Traffic CDM-625/A(s):

- HD-15F connector labeled “J1” on the Switch TMI(s), to
- DB-9F connector labeled “1:1 Control” on the Traffic CDM-625/A(s).

#### 4.4.3.5 EIA-422 Data Connections

**If EIA-422 is the driving traffic data type (see Figure 4-9 through Figure 4-11):**

**First**, connect the Control/Data Cable CA/WR0066 (for control/data purposes) between the Redundant CDM-625/A and the Switch RMI (see **Sect. 4.4.3.1**).

**Next**, do these steps to make all connections as per the operating configurations:

► **When you use the Switch CRS-316 TMI:** Do these steps to connect and secure the Control/Data Cable CA/WR0066 (for data purposes) between the Switch TMI(s) and Traffic CDM-625/A(s):

- DB-25M connector labeled “P1” on the Switch TMI(s), to
- DB-25F connector labeled “Data Interface” on the Traffic CDM-625/A(s).

**Then**, do these steps to connect and secure the Control Cable CA-0000069 (HD-15M to DB-9M, 6') between the Switch TMI(s) and the Traffic CDM-625/A(s):

- HD-15F connector labeled “J1” on the Switch TMI(s), to
- DB-9F connector labeled “1:1 Control” on the Traffic CDM-625/A(s).

► **When you use the Switch CRS-340 TMI:** Do these steps to connect and secure the Control/Data Cable CA/WR0066 (for control/data purposes) between the Switch TMI(s) and the Traffic CDM-625/A(s):

- DB-25M connector labeled “P1” on the Switch TMI(s), to
- DB-25F connectors labeled “Data Interface” on the Traffic CDM-625/A(s).

### 4.4.3.6 HSSI Data Connections

**If HSSI is the driving traffic data type (see Figure 4-9 and Figure 4-10):**

**First**, connect the Control/Data Cable CA/WR0066 (for control/data purposes) between the Redundant CDM-625/A and the Switch RMI (see **Sect. 4.4.3.1**).

**Next**, do these steps to connect and secure the Control Cable CA-0000069 (HD-15M to DB-9M, 6') between the Switch TMI(s) and the Traffic CDM-625/A(s):

- HD-15F connector labeled “J1” on the Switch TMI(s), to
- DB-9F connector labeled “1:1 Control” on the Traffic CDM-625/A(s).

**Then**, do these steps to connect and secure the Control Cable CA/WR9189-6 (HD-50M → HD-50M, 6') (for data purposes) between the Switch TMI(s) and Traffic CDM-625/A(s):

- 50-pin Type ‘HD’ HSSI (SCSI-II) female connector labeled “HSSI” on the Switch TMI(s), to
- 50-pin Type ‘HD’ HSSI (SCSI-II) female connector on the CIC-60 Adapter Module, to
- DB-25F connector labeled “Data Interface” on the Traffic CDM-625/A(s).

### 4.4.3.7 LVDS Data Connections

**If LVDS is the driving traffic data type (see Figure 4-9, Figure 4-11, and Figure 4-12):**

**First**, connect the Control/Data Cable CA/WR0066 (for control/data purposes) between the Redundant CDM-625/A and the Switch RMI (see **Sect. 4.4.3.1**).

**Then**, do these steps to connect and secure the Control/Data Cable CA/WR0066 (for data purposes) between the Switch TMI(s) and Traffic CDM-625/A(s):

- DB-25M connector labeled “P1” on the Switch TMI(s), to
- DB-25F connector labeled “Data Interface” on the Traffic CDM-625/A(s).

### 4.4.3.8 Ethernet Data Connections



- 1) **When you use the CDM-625/A in Dedicated Management Ethernet Port mode, this disables all four of the offline modem’s Ethernet ports unless you configure one of the four ports as the ‘Dedicated Management Port.’ For more information, see Sect. 5.4.13.3 CONFIG: IP → Setup in the CDM-625 or CDM-625A Advanced Satellite Modem Installation and Operation Manuals.**
- 2) **When you use Ethernet (with no Sub-Mux) as the dedicated data interface for the redundancy system, you must use the wired-thru method, explained in Sect. 4.4.3.8.1, to make all cabling connections.**

- 3) When you use Ethernet in combination with other data interfaces in the redundancy system – i.e., an IP Sub-Mux configuration – you must use the wired-around method, explained in Sect 4.4.3.8.2, to make all cabling connections.

#### 4.4.3.8.1 Ethernet Data Connection – Wired-thru Method (No Sub-Mux)



This redundancy approach is the *recommended* and *preferred* connection method.

The **wired-thru** Ethernet connection method is the easiest and simplest choice for Ethernet redundancy. This connection method – the same one that you use on the standard serial data interface – provides a single connection (i.e., using one of four available RJ-45 ports) for the User Data Interface, and provides simple Form-C relays that route the Ethernet connection from your user connection to either the Traffic or Redundant Modem.

See Figure 4-9 through Figure 4-11 – If the wired-thru method of Ethernet is the driving traffic data type<sup>Note 1</sup>:

**First**, connect the Control/Data Cable CA/WR0066 (for control/data purposes) between the Redundant CDM-625/A and the Switch RMI (see **Sect. 4.4.3.1**).

**Next**, do these steps to connect and secure the Ethernet Data Cable CA-0000121 (HD-50M to RJ-45M, 6') between the Redundant CDM-625/A and the Switch RMI:

- RJ-45F "10/100 Ethernet" connector labeled "1" (Port1) on the Redundant CDM-625/A, to
- HD-50M connector labeled "J1" on the Switch RMI.

**Then**, connect and secure the Control Cable CA-0000069 (HD-15M to DB-9M, 6') between the Switch CRS-316 or CRS-336 TMI(s) and the Traffic CDM-625/A(s).

**Finally**, do these steps to connect and secure the CAT5 Data Cable PP/CAT5FF7FTGY (RJ-45M to RJ-45M, 7') between the Switch TMI(s) and Traffic CDM-625/A(s):

- RJ-45F connector labeled "J5" on the Switch TMI(s)<sup>Notes 2,3</sup>, to
- RJ-45F "10/100 Ethernet" connector labeled "1" (Port 1) on the Traffic CDM-625/A(s).



- 1) Where the traffic data type is Ethernet, you can only use one of four Ethernet ports, in Ethernet Bridge Mode, on the CDM-625/A rear panel.
- 2) You may use the Switch CRS-316 for single-port Ethernet Bridge Mode or EIA-530, but not both at the same time. The CRS-316 does not handle Sub-Mux operation (where the CDM-625/A may use both Ethernet Bridge Mode and EIA-530 simultaneously). Sub-Mux operation is explained in the next section, Sect. 4.4.3.8.2 Ethernet Data Connection – Wired-around Method (Sub-Mux).

- 3) You may use the CRS-336 for single-port Ethernet Bridge Mode or HSSI, but not both at the same time. The CRS-336 does not handle Sub-Mux operation (where the CDM-625/A may use Ethernet Bridge Mode and EIA-530 simultaneously). Sub-Mux operation is explained in the next section, Sect. 4.4.3.8.2 Ethernet Data Connection – Wired-around Method (Sub-Mux).

#### 4.4.3.8.2 Ethernet Data Connection – Wired-around Method (Sub-Mux)



While this redundancy approach is *not* recommended, you *may* use it once you study the LAN and WAN sides of the IP networks.

Sub-Mux is a secondary framing structure which combines one to four ports of 10/100 Ethernet (IP) traffic with any currently available combination of framing and interface type (i.e. HSSI, EIA-422, ASI or G.703, but excluding IP itself). You must select a specific ratio in order to reference the composite data rate (to the modulator and from the demodulator) to the primary, non-IP data interface rate.



- **Chapter 15. IP SUB-MUX in the CDM-625 Advanced Satellite Modem Installation and Operation Manual (CEFD P/N MN-CDM625)**
- **Appendix N. IP SUB-MUX in the CDM-625A Advanced Satellite Modem Installation and Operation Manual (CEFD P/N MN-CDM625A).**

You must use the **wired-around** Ethernet connection with the CDM-625/A modem and Switch when you use CDM-625/A Sub-Mux mode. When you configure Ethernet Bridge Mode for the wired-around method, this gives full redundancy capability to both selected data types in Sub-Mux mode. However, you must take care to ensure there are no Ethernet network loops or connection problems – *you should use this method only if the CDM-625/A will be using the Sub-Mux*. In general, you may use the wired-around approach in a hub-to-remotes configuration.

**Figure 4-12** depicts the cabling example for a 1:N Redundant system with Traffic modems 3 and 9 configured for IP Sub-Mux. Do these steps when you use IP Sub-Mux with any other traffic data type:

**First**, connect and secure the Control/Data Cable CA/WR0066 (for control/data purposes) between the Redundant CDM-625/A and the Switch RMI (see **Sect. 4.4.3.1**).

**Next**, connect and secure the desired serial traffic data cables as described in **Sects. 4.4.3.2** through **4.4.3.5**.

**Then**, for each CDM-625/A using Sub-Mux, connect a user-provided CAT5 Ethernet data cable from any one of the four 10/100 Ethernet Bridge Mode ports on the CDM-625/A to one port of a user-provided 10/100/1000 Layer 2 Ethernet Switch.

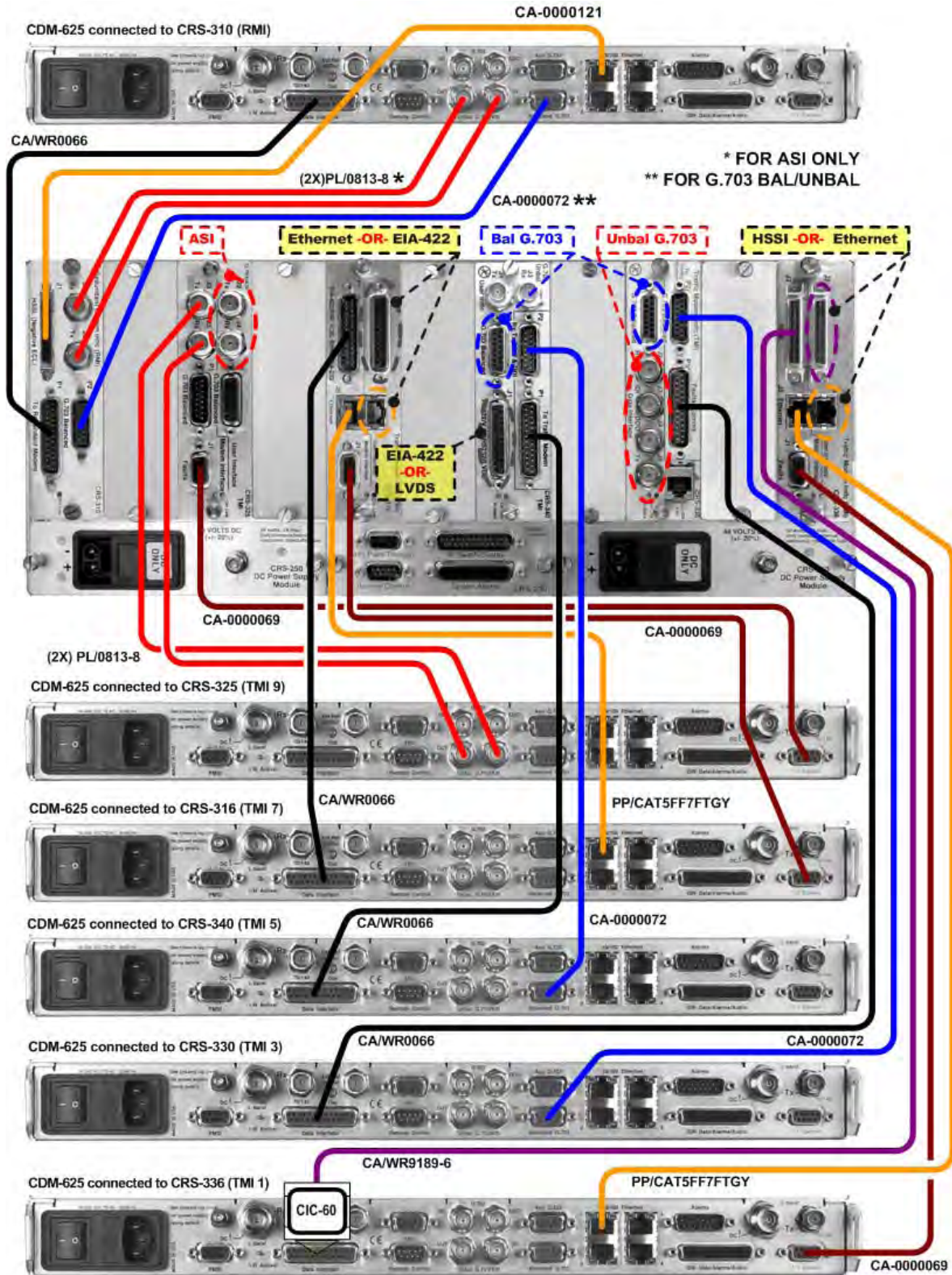
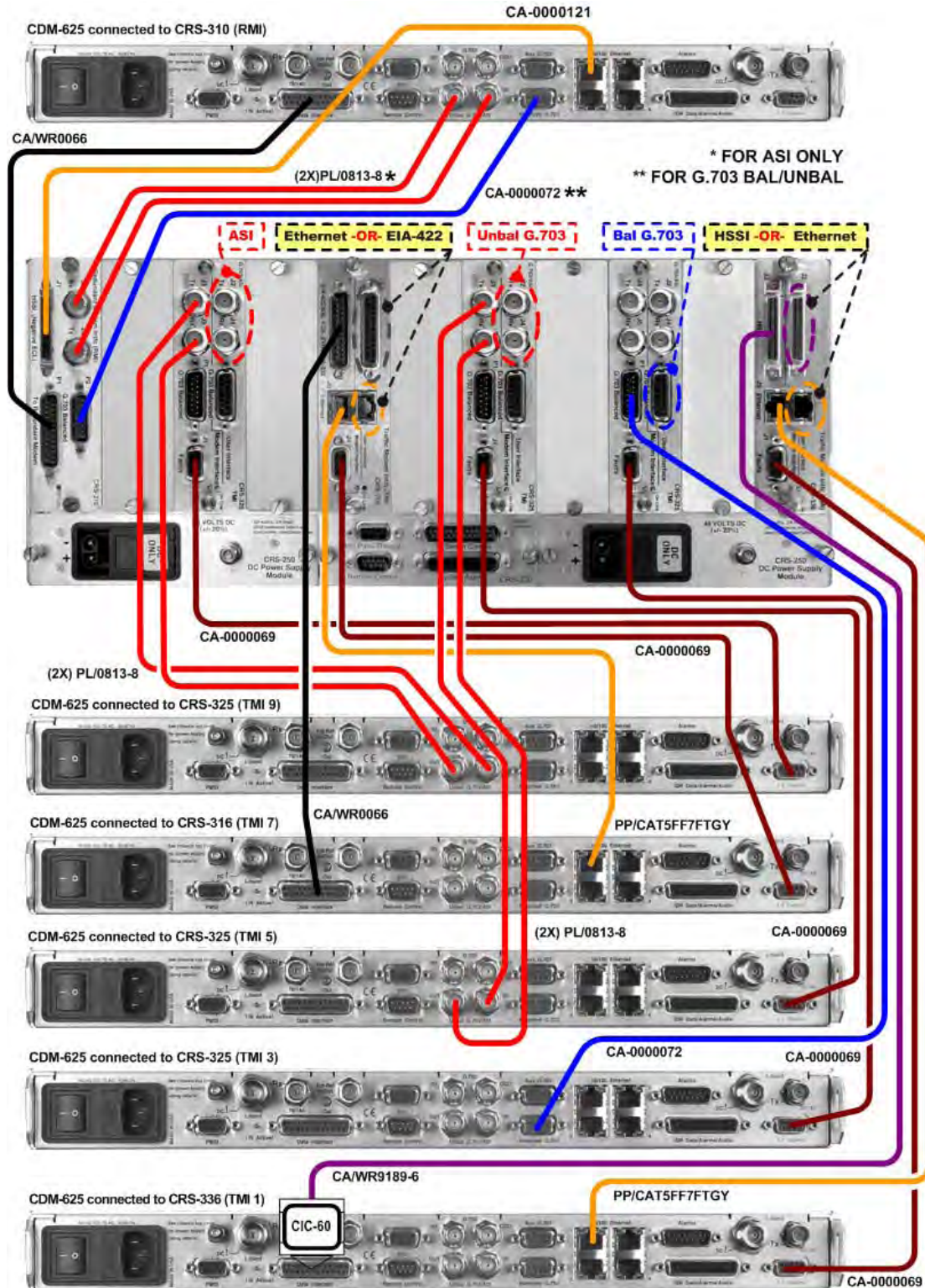


Figure 4-9. CRS-300 to CDM-625/A Cable Connection Example – G.703-driven Configuration

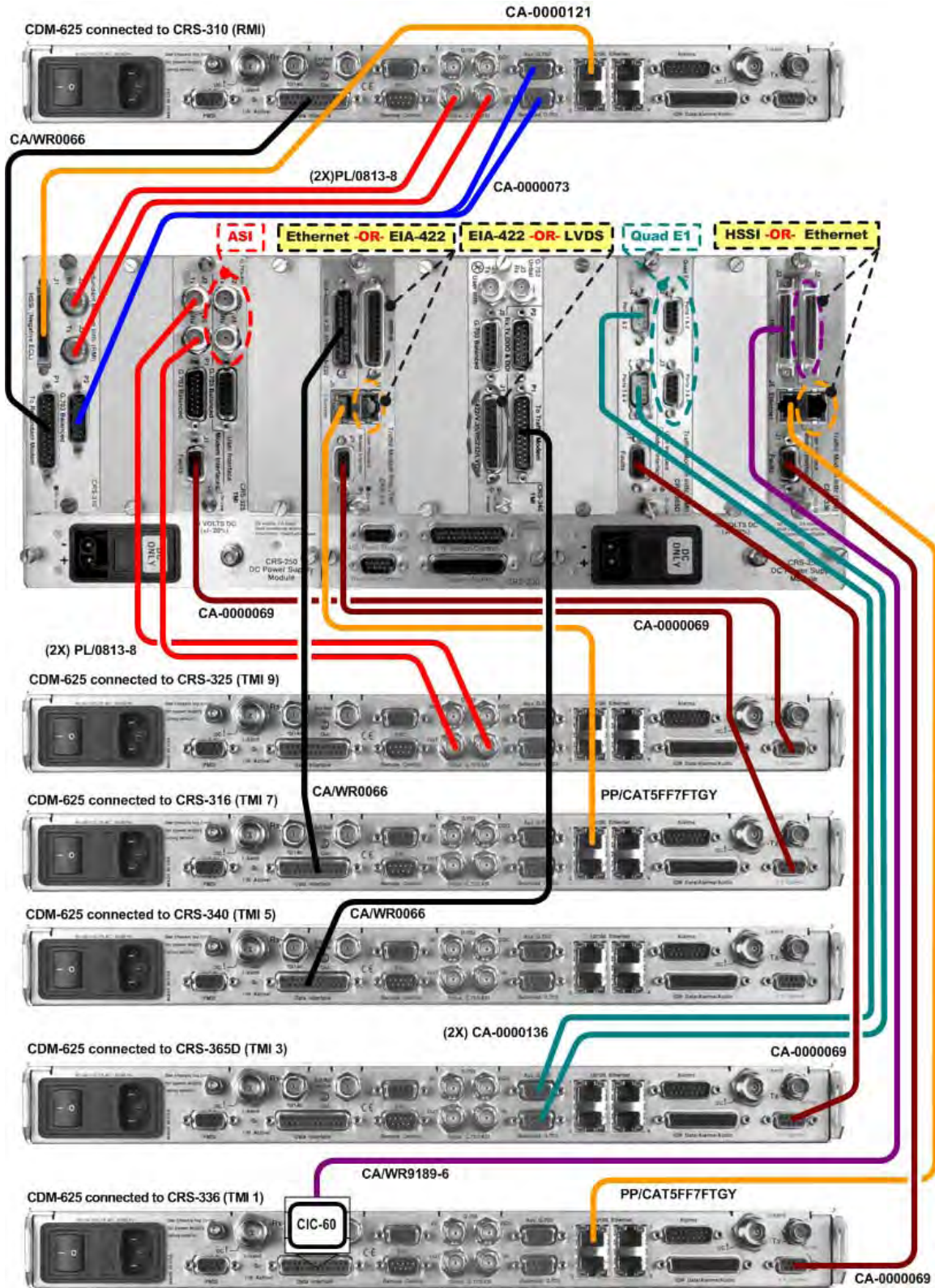
(Connections shown for RMI and TMIs 1, 3, 5, 7, and 9 only)



**Figure 4-10. CRS-300 to CDM-625/A Cable Connection Example – G.703-driven Configuration**

(Connections shown for RMI and TMIs 1, 3, 5, 7, and 9 only)





**Figure 4-11. CRS-300 to CDM-625/A Cable Connection Example – Quad E1-driven Configuration**

(Connections shown for RMI and TMIs 1, 3, 5, 7, and 9 only)

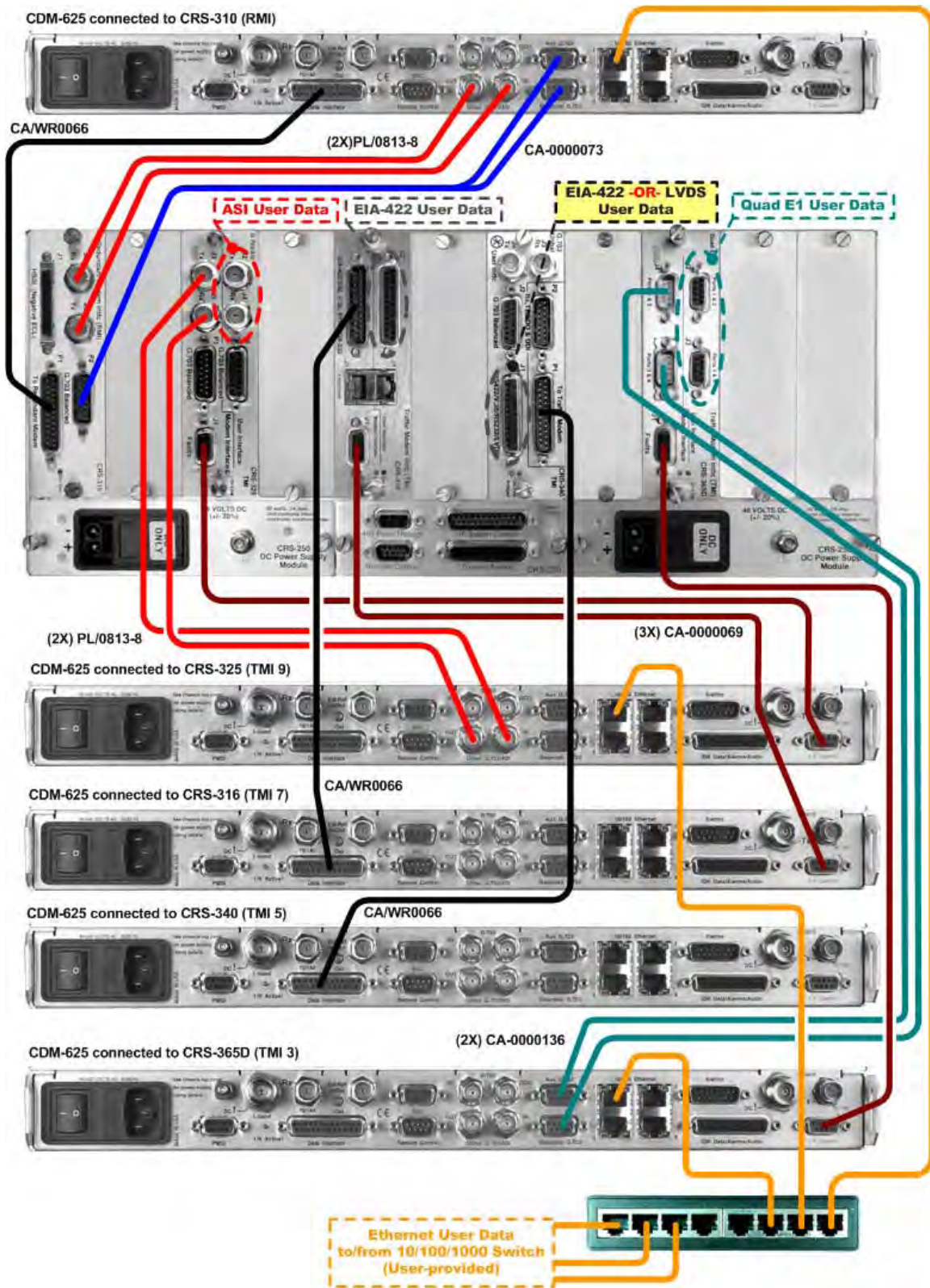


Figure 4-12. CRS-300 to CDM-625/A Cable Connection Example – Sub-Mux TMIs 3 & 9  
(Connections shown for RMI and TMIs 1, 3, 5, 7, and 9 only)

#### 4.4.4 Data Connections – CRS-300 to User

You must connect your traffic data from the external router, multiplexing equipment, or test data generator to the connectors on the Switch TMI labeled “User Data Interface”. This interface replaces the direct connection to the Traffic CDM-625/A’s “Data Interface” connectors.

For Quad E1 operation, the optional CA-0000163 and CA-0000164 Adapter Cables may be purchased from Comtech EF Data to adapt the Balanced G.703 or Auxiliary G.703 9-pin Type ‘D’ female connectors to either a standard 15-pin Type ‘D’ or a RJ-48 female connection pair. See **Figure B-30** or **Figure B-31** in **Appendix B. CABLE DRAWINGS**.



- 1) **Because the Redundant Modem’s function is to replace a faulted Traffic Modem, the Switch RMI does not have a User Data Interface.**
- 2) **Ensure that you correctly configure the modem operation for Balanced or Unbalanced G.703 data traffic.**

#### 4.4.5 Data Connections – CRS-350 Engineering Service Channel (ESC) Switch

##### 4.4.5.1 ESC Data Connections – CRS-350 to Modems

See **Figure 4-13** do these steps to connect and secure the Multi-purpose Cable CA-0000074 (2 places) between the rear panels of the CRS-350 and the CDM-625/A(s):

- DB-25F Jxx “Overhead,” D-9M Paxx “Audio,” and DB-15M Pbx “IDR Alarms” connectors on the CRS-350 rear panel (where xx specifies the number 1 through 10 Traffic Modem, and 11 is reserved for the Redundant Modem), to
- HD-44F “IDR Data/Alarms/Audio” and DB-9M “ESC” connectors on the Redundant and Traffic CDM-625/As.

##### 4.4.5.2 ESC Data Connections – CRS-350 to User

You must connect your equipment to the correct corresponding plug-in UDI (User Data Interface) module on the front panel of the CRS-350. This replaces the direct connection to the Traffic CDM-625/A’s “IDR”, “Audio” and “Overhead” ports.

#### 4.4.6 Operation of the CDM-625/A in CDM-600/L Emulation Mode

With the exception of EIA-232 type traffic data handling, the CDM-600 Emulation Mode enables the CDM-625/A to serve as an operationally transparent replacement unit for CDM-600/L Open Network Satellite Modems.

#### 4.4.6.1 Preparing the CDM-625/A for Operation in CDM-600/L Emulation Mode

The CDM-625/A may be set for operation in CDM-600/L Emulation mode by selecting this mode of operation from the CDM-625/A front panel. From the top-level menu:

**SELECT: UTILITY → Em → Emulation Mode**

Use the ▼ ▲ keys on the keypad to select the appropriate emulation mode.

The choices from this display are:

- **Normal: CDM-625 (or CDM-625A)**
- **Emulate: CDM-600**
- **Emulate: CDM-600L**

Once you select the desired emulation mode, press the **ENT** key to save the configuration.

#### 4.4.6.2 Control and Data Connections – CRS-300 to Modems in CDM-600/L Emulation Mode

For each CDM-625/A that replaces a CDM-600/L modem – See **Figure 4-14** and do these steps to connect and secure the CA/WR0066 Control/Data Cable cables between each CDM-625/A and the Switch:

- DB-25M connector labeled “P1” on the Switch RMI or TMI(s), to
- DB-25F connector labeled “Data Interface” on the CDM-625/A.



See **Sect. 4.4.3 Control and Data Connections – CRS-300 to Modems** for the system configuration and cable interconnection details for the various traffic data types that are available in this operational mode.

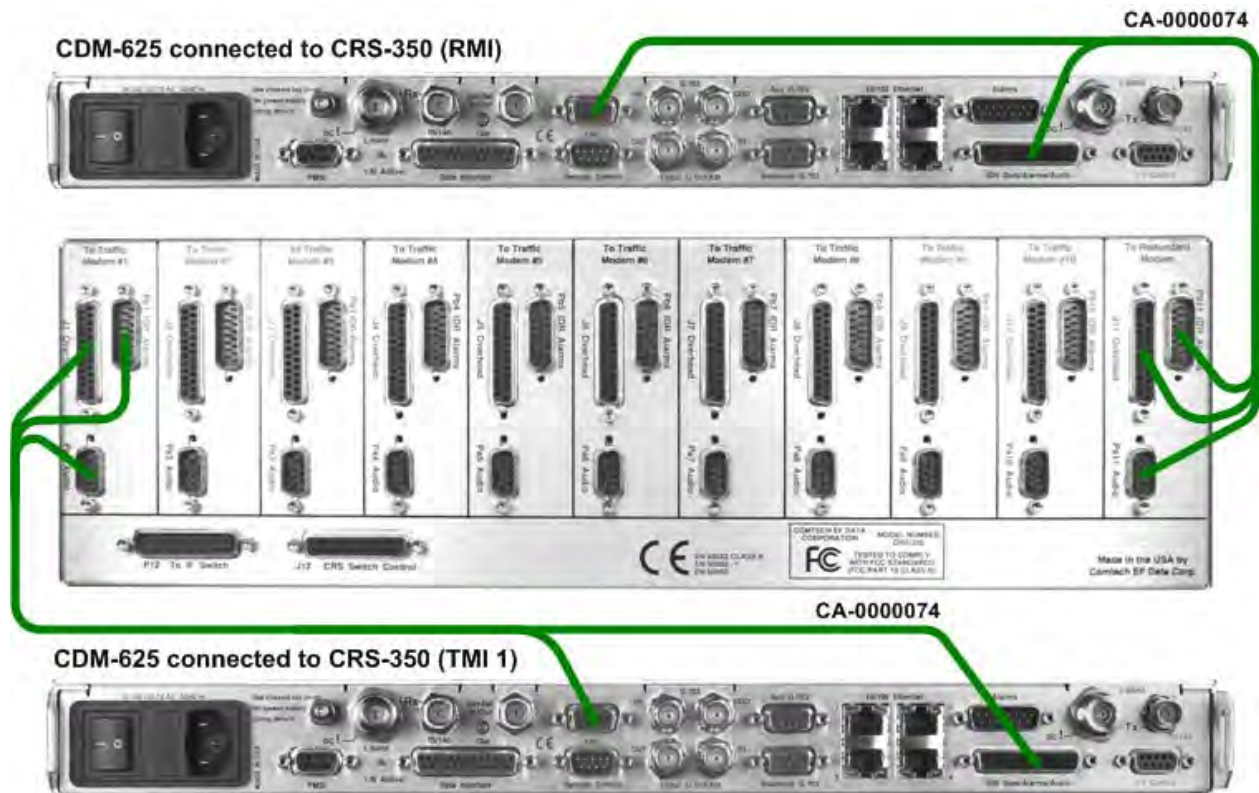
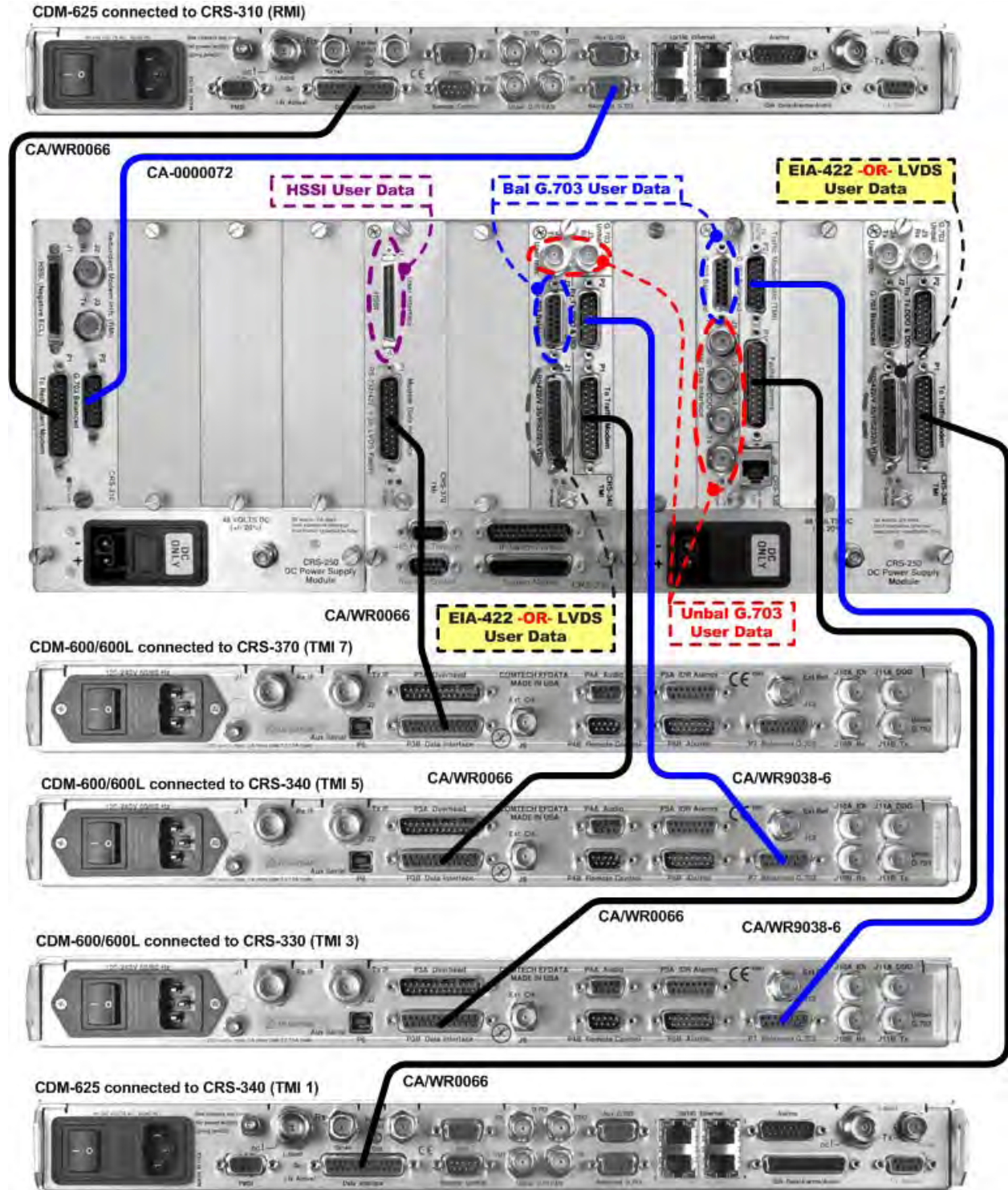


Figure 4-13. Cabling Example for CRS-350 to CDM-625/A  
(Connections shown for RMI and TMI 1 only)



**Figure 4-14. Data Cables – CRS-300 to CDM-625/A (CDM-600/L Emulation Mode)**  
(Connections shown for RMI and TMIs 1, 3, 5, and 7 only)

## **4.5 CDM-570/A, CDM-570L/AL Modem Connections**

- **Control and Data Connections – CRS-300 to Modems**
- **User Data Connections – CRS-300 to User**

---

## 4.5 CDM-570/A, CDM-570L/AL Modem Connections

If adding a modem to an **operating** 1:N system, care needs to be taken not to interfere with the existing Traffic Modem. The cabling, power-up sequence must be correct to avoid contention in the system from the modem Tx carrier. This sequence is described in **Sect. 6.2.2.5 CONFIG: ACTIVE (Activate Modems)**.



**Traffic modems with differing data types can all be supported by the Redundant Modem.**

### 4.5.1 Control and Data Connections – CRS-300 to Modems

The 25-pin Control/Data Cable CA/WR0066 provides the EIA-422/232 traffic data path and serial communication path between the Switch and the modems. Therefore, you must always use this cable, even when the data type is G.703.



**The Switch TMIs (CRS-320 (obsolete) and CRS-340) feature jumpers that are pre-set to ensure proper operation with traffic data for EIA-422 with RTS/CTS, DTR/DSR signals. See Chapter 5. MODEM, TMI, AND SWITCH CONFIGURATION for this important configuration information.**

See **Figure 4-15** and do these steps to connect and secure the CA/WR0066 cables between the Switch and each CDM-570/A or CDM-570L/AL:

- DB-25M connector labeled “P1” on the Switch RMI or TMI(s), to
- DB-25F connectors labeled “Data Interface” on the CDM-570/A or CD-570L/ALs.

**If G.703 is the traffic data type**, also do these steps to connect and secure the Data Cable CA/WR11999-6, which you must use for either Balanced or Unbalanced G.703 **Data**:

- DB-15M connector labeled “P2” on the Switch RMI or TMI(s), to
- DB-15F connectors labeled “Balanced E1/T1” on the CDM-570/A or CDM-570L/ALs.

### 4.5.2 User Data Connections – CRS-300 to User

You must connect your traffic data from the multiplexing equipment or test data generator to the connectors labeled “User Data Interface” on the Switch TMI(s). This interface replaces the direct connection to the Traffic Modem’s “Data Interface” connectors.



- 1) **Because the Redundant Modem’s function is to replace a faulted Traffic Modem, the Switch RMI does not have a User Data Interface.**
- 2) **Ensure that you correctly configure modem operation for Balanced or Unbalanced G.703 data.**



For T1/E1 operation, the optional CN-000268 T1/E1 Adapter (see **Figure B-32** in **Appendix B. CABLE DRAWINGS**) may be purchased from Comtech EF Data to adapt the Balanced G.703 DB-15F connector on the User Data side of the Switch TMI to a RJ-48 female connection.

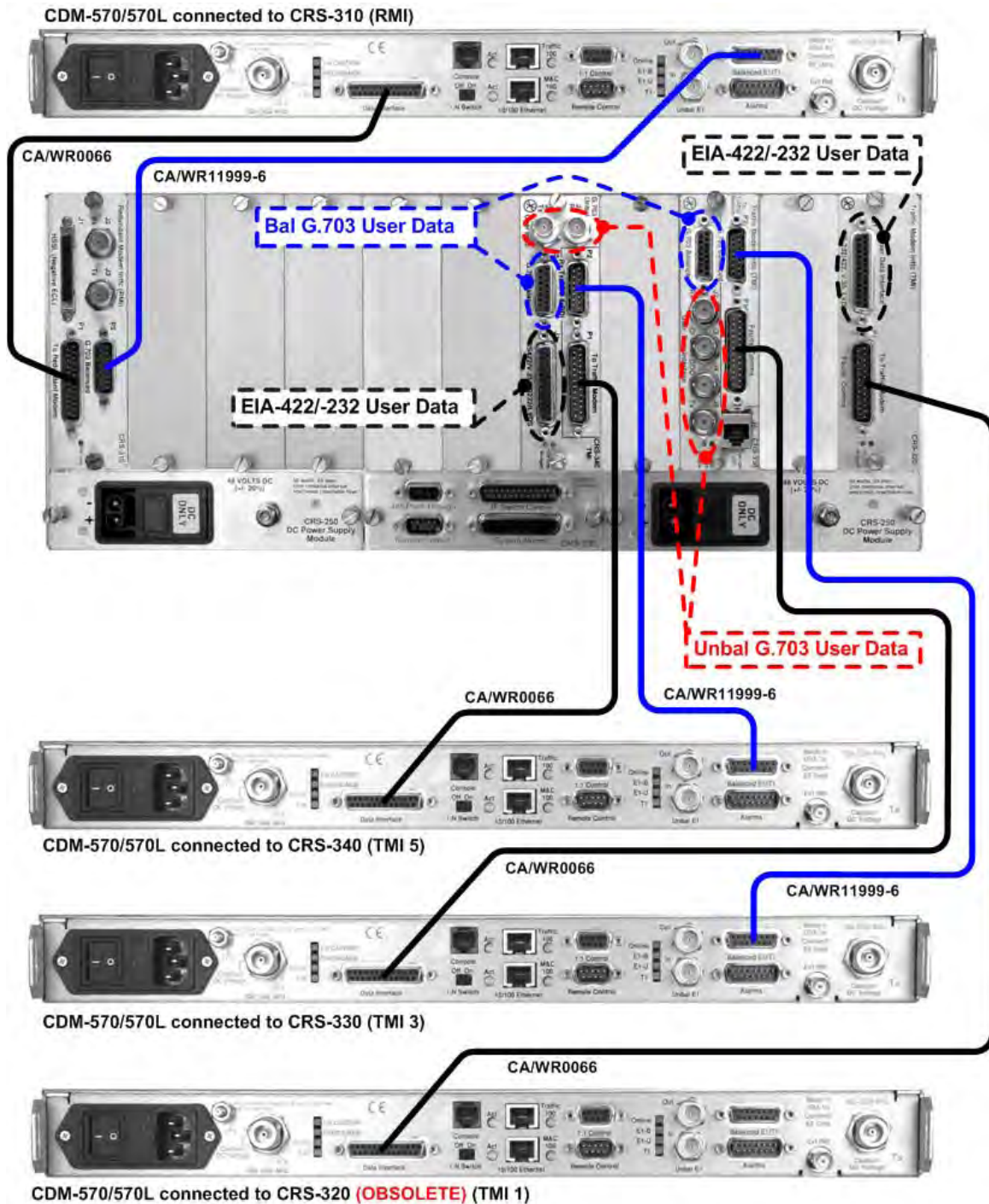


Figure 4-15. Data Cable Connection Example – CRS-300 to CDM-570/A or CDM-570L/AL  
(Connections shown for RMI and TMIs 1, 3, and 5 only)



## **4.6 SLM-5650/5650A Modem Connections**

- **RMI/TMI Limitations and Considerations**
- **Control Cable Connections – CRS-300 to Modems**
- **Traffic Data Connections – CRS-300 to Modems**
- **Ethernet Traffic Data Connections – CRS-300 to Modems**
- **User Data Connections – CRS-300 to User**
- **ESC Data Connections – CRS-350 to Modems**
- **User ESC Data Connections – CRS-350 to User**

---

## 4.6 SLM-5650/5650A Modem Connections

If adding a modem to an **operating** 1:N system, care needs to be taken not to interfere with the existing Traffic Modem. The cabling, power-up sequence, and communication connections must be correct to avoid contention in the system from the modem Tx carrier. This information is detailed in **Sect. 6.2.2.5 CONFIG: ACTIVE (Activate Modems)**.

### 4.6.1 RMI/TMI Limitations and Considerations

Some consideration must be made when choosing which TMIs can be mixed within the same Switch. Because the Switch RMIs (CRS-306/-307) cannot provide connections to all of the data types on the SLM-5650/5650A Redundant Modem, the customer must choose which RMI card is the best choice for use with the Switch. This will then dictate which TMIs that the Switch can support.



- 1) **You must equip your Redundant Modem with the same option card(s) as any Traffic Modem.**
- 2) **The Switch TMIs feature jumpers that are pre-set to ensure proper operation with the following traffic data:**
  - For **EIA-422** with RTS/CTS, DTR/DSR signals using the CRS-316
  - For **HSSI** with CA/TA signals using the CRS-336

See **Chapter 5. MODEM, TMI, AND SWITCH CONFIGURATION** for this important configuration information.

- 3) **When you use the SLM-5650/5650A with the Switch, the modem is NOT compatible for use in a Vipersat network.**
- 4) **Modems using a single port (i.e., Port 1) of the 4-Port Network Processor Module can NOT be mixed with modems using EIA-530 or HSSI data interfaces, or the G.703 or single port Gigabit Ethernet card options.**

### 4.6.2 Control Cable Connections – CRS-300 to Modems

The Control Cable CA/WR12136-1 provides the serial communication path between the Switch and the modems and controls the modem's external Tx IF-mute control line. **You must always use this cable.**

To provide user access to the AGC and I&Q outputs of the modem, the CA/WR12842-6 Control Y-Cable, sold separately, is available for use in place of the CA/WR12136-1 cable. See **Appendix B. CABLE DRAWINGS** for detailed information about these optional cable assemblies.

See **Figure 4-16** through **Figure 4-18** and do these steps to connect and secure the CA/WR12136-1 cable (or the CA/WR12482-6 Control Y-Cable, if used) between the Switch and each SLM-5650/5650A:

- HD-15F connector labeled “J1” on the Switch RMI or TMI(s), to
- HD-15F connector labeled “J9 Auxiliary” on the SLM-5650/5650A.

### 4.6.3 Traffic Data Connections – CRS-300 to Modems

*Referring to Figure 4-16:*

**If HSSI is the traffic data type**, do these steps to connect and secure the HSSI Data Cable CA/WR9189-6 between the Switch and each SLM-5650/5650A:

- HSSI (HD-50F) connector labeled “J2” on the Switch RMI or “J3” on the Switch TMI(s), to
- HSSI (HD-50F) connector labeled “J7 HSSI” on the SLM-5650/5650A.

**If EIA-530/-232 is the traffic data type**, do these steps to connect and secure the Control/Data Cable CA/WR0066 (for data purposes) between the Switch and each SLM-5650/5650A:

- DB-25M connector labeled “P2” on the Switch RMI, or “P1” on the Switch TMI(s), to
- DB-25F connector labeled “J6 EIA530” on the SLM-5650/5650A.

*Referring to Figure 4-17:*

**If Balanced G.703 is the traffic data type**, do these steps to connect and secure the CA/WR9038-1 cable between the Switch and each SLM-5650/5650A:

- DB-15M connector labeled “P1” on the Switch RMI or TMI(s), to
- DB-15F connector labeled “J1 Bal Data” on the SLM-5650/5650A.

**If Unbalanced G.703 is the traffic data type**, do these steps to connect and secure the pair of BNC PL/0813-8 cables between the Switch and each SLM-5650/5650A:

- BNC connectors labeled “J4 Tx” on the Switch RMI, or “J3 Tx” on the Switch TMI(s), to BNC connectors labeled “J3 Rx” on the SLM-5650/5650A, and
- BNC connectors labeled “J3 Rx” on the Switch RMI, or “J5 Rx” on the Switch TMI(s), to BNC connectors labeled “J2 Tx” on the SLM-5650/5650A.

### 4.6.3.1 Ethernet Traffic Data Connections

Due to limitations of its backplane, the Switch can support **Single-port Ethernet Bridge Mode** only.

#### 4.6.3.1.1 Ethernet Bridge Mode via the Optional GbE Interface

When the SLM-5650/5650A modems are equipped with the optional single-port 10/100/1000 Base-T (GbE) plug-in module, only **Single-port Ethernet Bridge Mode** is possible. See **Figure 4-16** and do these steps to connect and secure all CAT5 Data Cables PP/CAT5FF3FTGY:

- RJ-45 connector labeled “J5” on the Switch RMI or TMI, to
- RJ-45 connector labeled “J1” on the optional GbE plug-in module.

#### 4.6.3.1.2 Ethernet Bridge Mode via the Optional NP Interface

When the SLM-5650/5650A modems are equipped with the optional multi-port Network Processor (NP) plug-in module, only **Single-port Ethernet Bridge Mode** is possible. As shown in **Figure 4-18**, connect and secure all CAT5 Data Cables PP/CAT5FF3FTGY:

- RJ-45 connector labeled “Port 1” on the Switch RMI or TMI, to
- RJ-45 connector labeled “Port 1” on the optional Network Processor (NP) Interface card.



**Do not connect to Port 2 through Port 4 on the Switch RMI, TMI, or optional Network Processor (NP) Interface when operating in Single-port Ethernet Bridge Mode.**

### 4.6.4 User Data Connections – CRS-300 to User

You must connect your traffic data from the external router, multiplexing equipment, or test data generator to the connectors on the Switch TMI labeled “User Data Interface”. This interface replaces the direct connection to the Traffic Modem’s “Data Interface” connectors.

Because the Redundant Modem’s function is to replace a faulted Traffic Modem, the Switch RMI does not have a User Data Interface.

See **Sect. 1.4.3.3 Modem Interface Cards** for detailed information on the Switch RMI and TMI cards available for use with the SLM-5650/5650A modems.

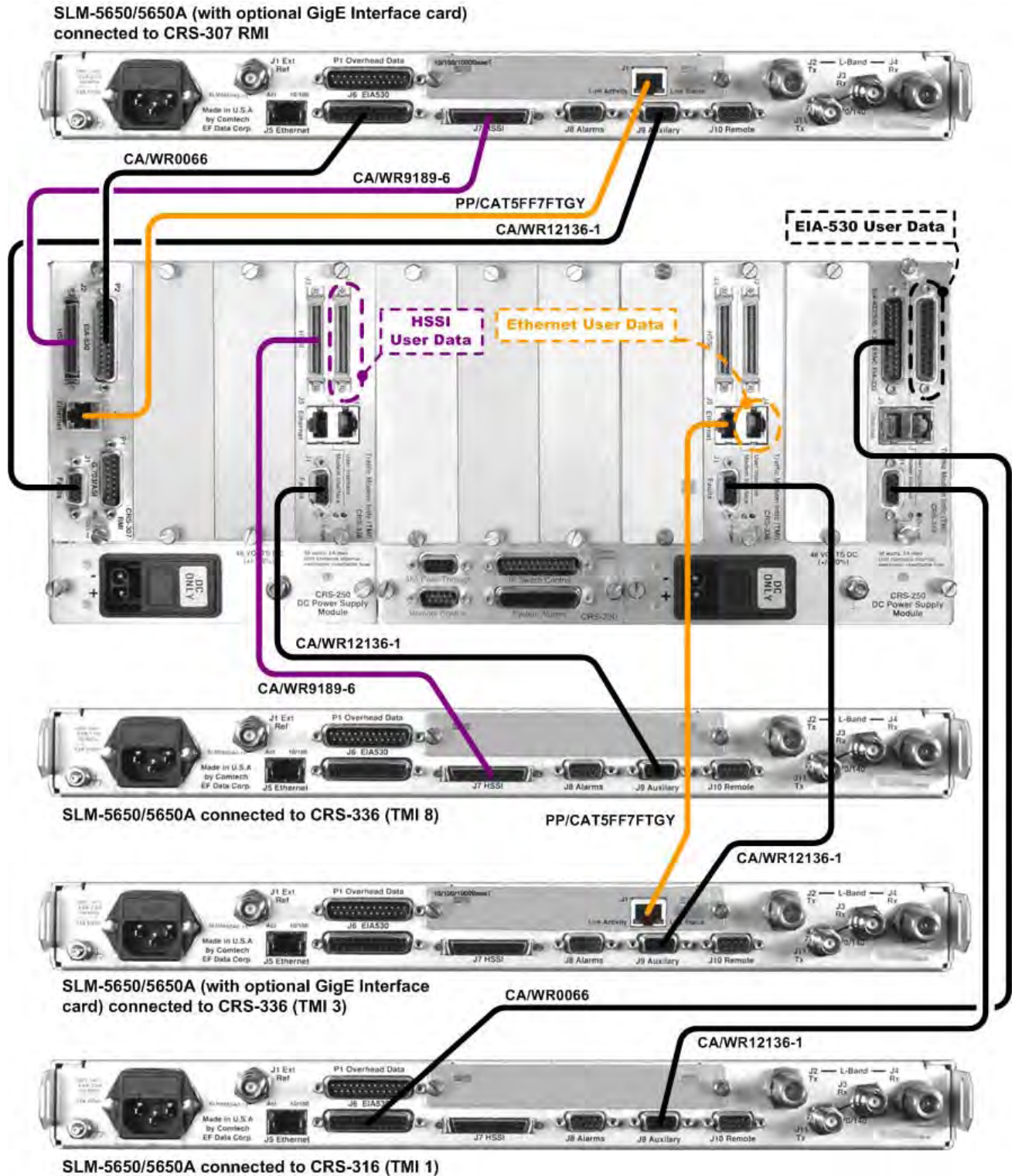
### 4.6.5 ESC Data Connections – CRS-350 to Modems

See **Figure 4-19** and do these steps to connect and secure the Control/Data Cable CA/WR0066 between the rear panel of the CRS-350 and each SLM-5650/5650A:

- DB-25F Jxx “Overhead” connector on the CRS-350 rear panel (where xx specifies the numbers 1 through 10 Traffic SLM-5650/5650As, and “R11” is reserved for the Redundant SLM-5650/5650A), to
- DB-25M “P1 Overhead Data” connector on each SLM-5650/5650A.

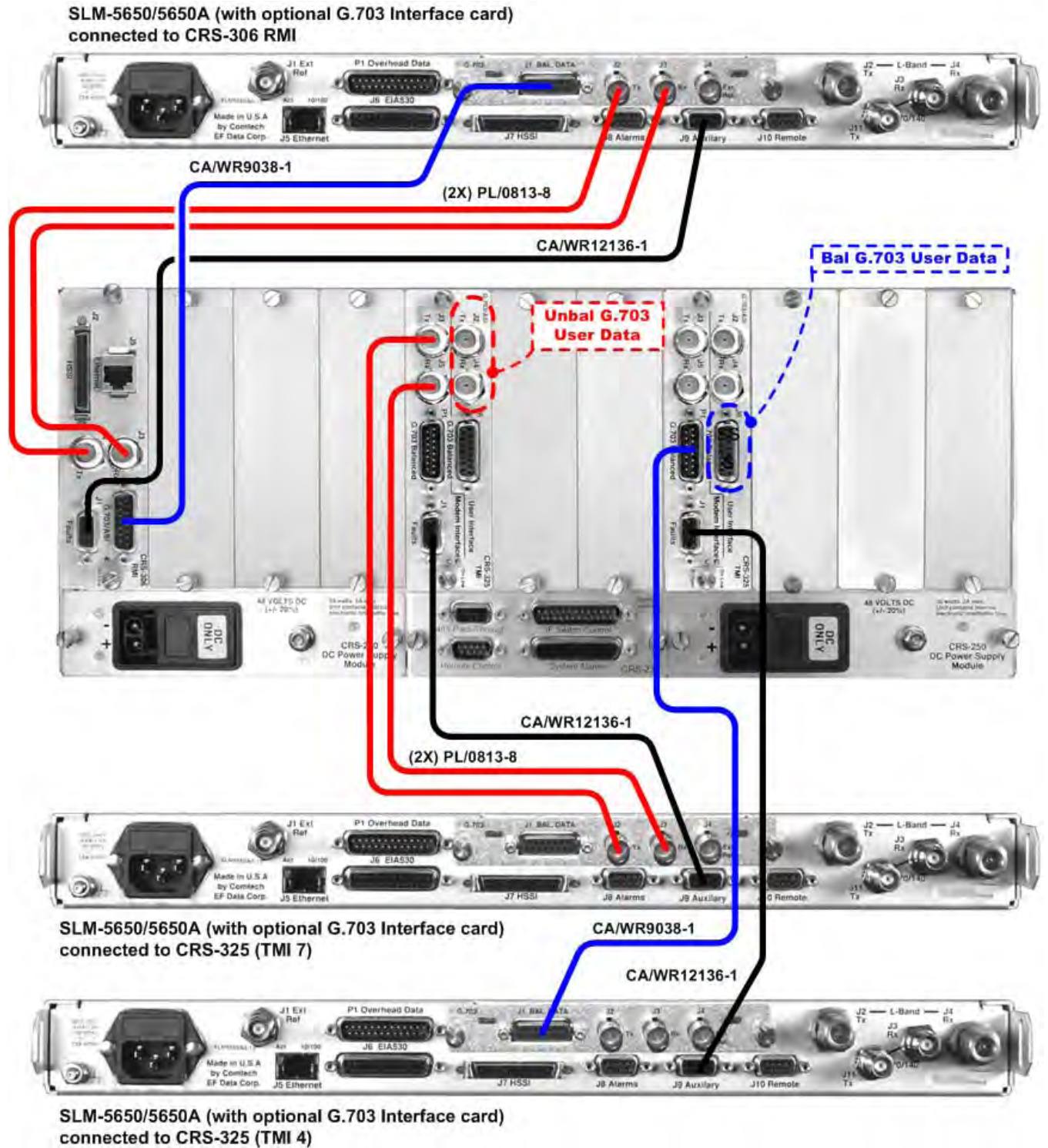
#### **4.6.6 User ESC Data Connections – CRS-350 to User**

You must connect your equipment to the correct corresponding plug-in User Data Interface (UDI) card on the front panel of the CRS-350. This replaces the direct connection to the Traffic SLM-5650/5650A’s “Overhead” port.

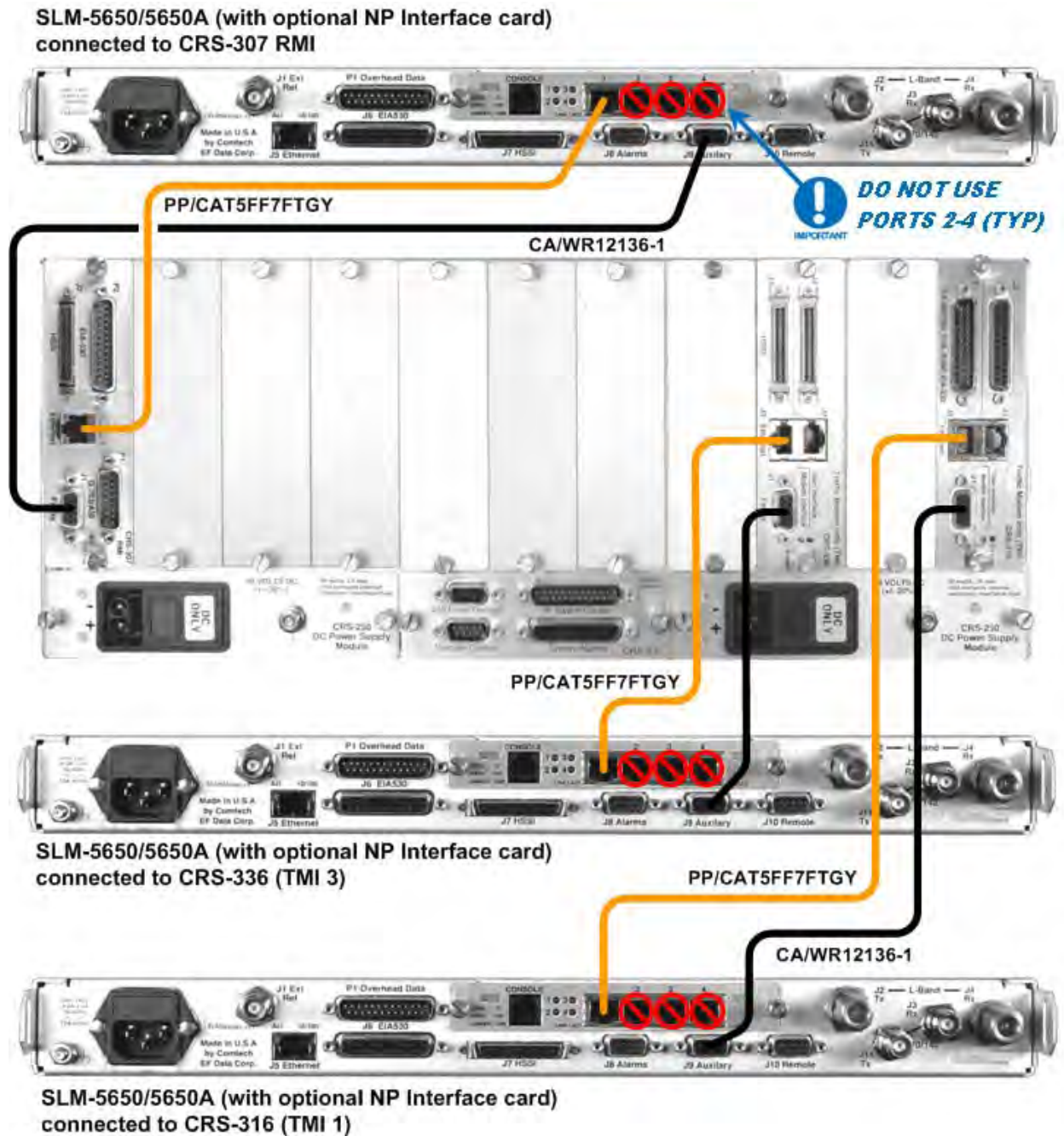


**Figure 4-16. Control and Data Cables Example #1 – CRS-300 to SLM-5650/5650A**  
(Connections shown for RMI & TMIs 1, 3, and 8 only)

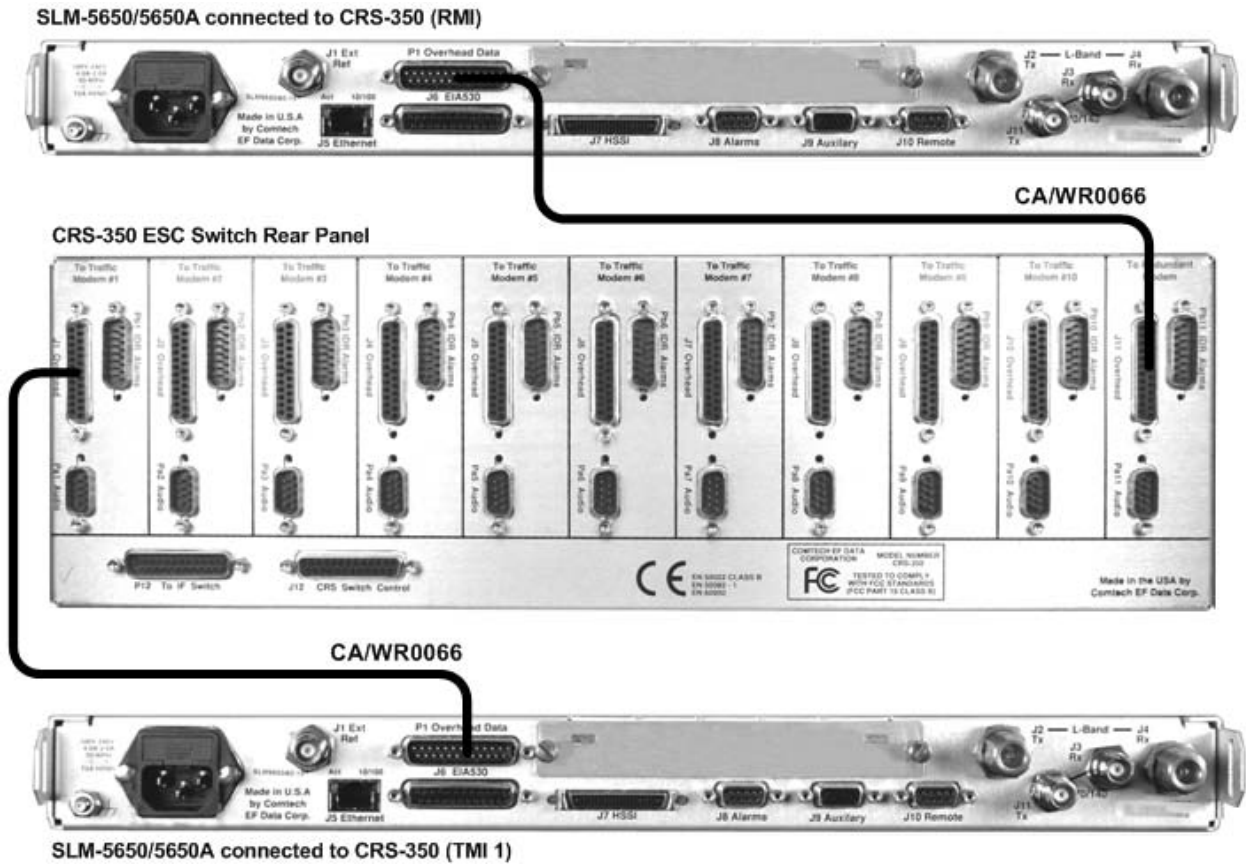




**Figure 4-17. Control and Data Cables Example #2 – CRS-300 to SLM-5650/5650A  
(Connections shown for RMI & TMIs 4 and 7 only)**



**Figure 4-18. Control and Data Cables Example #3 – CRS-300 to SLM-5650/5650A  
(Connections shown for RMI & TMIs 1 and 3 only)**



**Figure 4-19. Cabling Example for CRS-350 to SLM-5650/5650A  
(Connections shown for RMI and TMI 1 only)**



## **4.7 CDM-Qx/QxL Modem Connections**

- **RMI/TMI Limitations and Considerations**
- **EIA-485 Connections – CRS-300 to Modems**
- **Control Y-Cable Connections – CRS-300 to Modems**
- **Traffic Data Connections – CRS-300 to Modems**
- **User Data Connections – CRS-300 to User**

---

## 4.7 CDM-Qx/QxL Modem Connections

If adding a modem to an **operating** 1:N system, care needs to be taken not to interfere with the existing **traffic**. The cabling, power-up sequence and COMs connections must be correct to avoid contention in the system from the modem Tx carrier. This information is detailed in **Sect. 6.2.2.5 CONFIG: ACTIVE (Activate Modems)**.

As shown in **Figure 4-22** through **Figure 4-25**, the CA/WR12069-1 Control Y-Cable provides fault information from the modem and IF-Mute to the modem. **You must always use this cable.**

### 4.7.1 RMI/TMI Limitations and Considerations

Because the CDM-Qx/QxL redundant modem can only support one type of data interface, the Switch TMIs cannot be mixed within the same Switch.



**The Switch TMIs feature jumpers that are pre-set to ensure proper operation with the following traffic data:**

- For **EIA-422** with RTS/CTS, DTR/DSR signals using the CRS-316
- For **HSSI** with CA/TA signals using the CRS-336

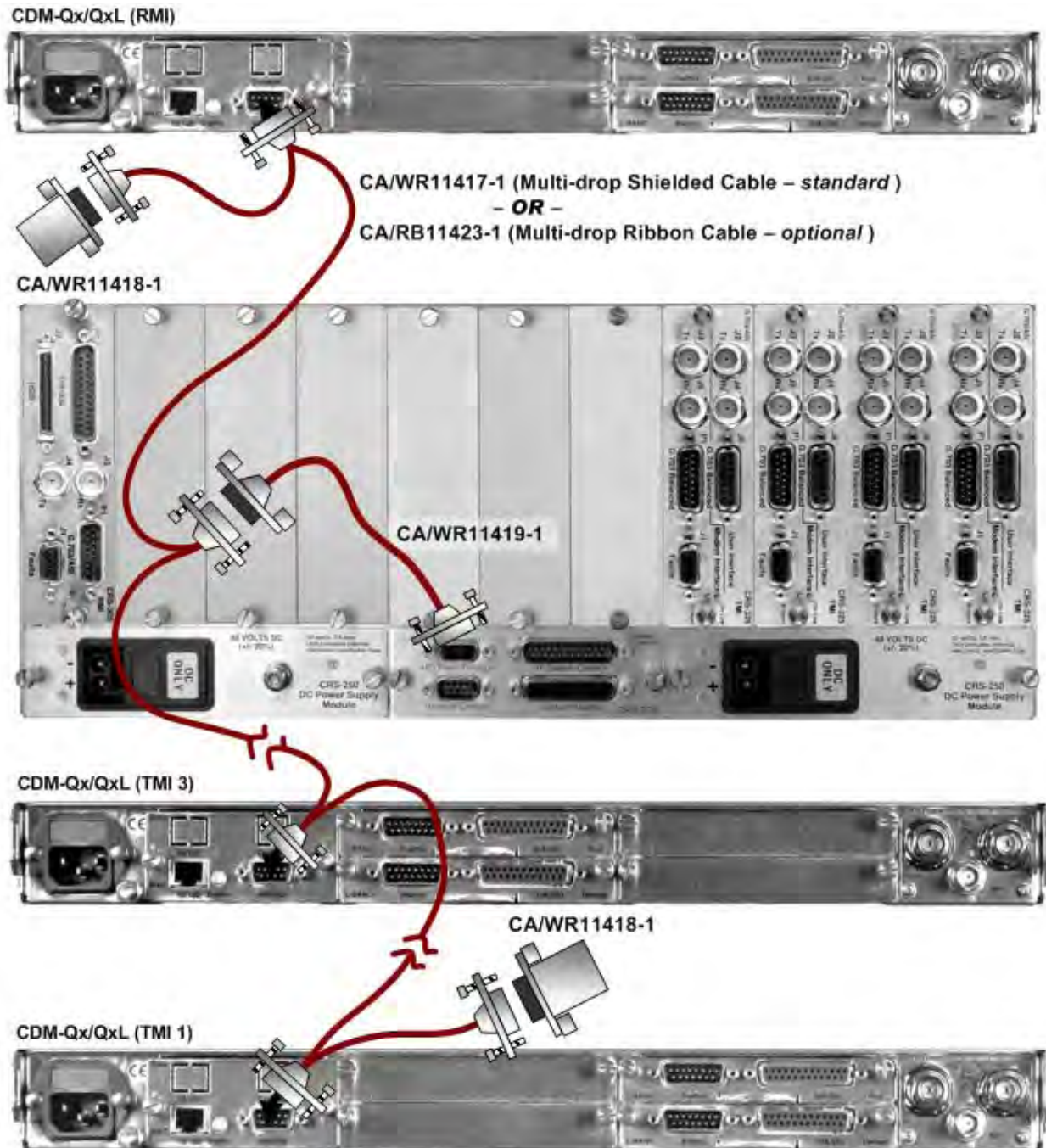
See **Chapter 5. MODEM, TMI, AND SWITCH CONFIGURATION** for this important configuration information.

### 4.7.2 EIA-485 Connections – CRS-300 to Modems

An EIA-485 Multi-drop cable provides the communication path between the Switch and the modems. There are two types of EIA-485 Multi-drop cable available: a standard CA/WR11417-1 shielded cable to guard against EMC (Electromagnetic Compatibility) concerns, or an optional CA/RB11423-1 ribbon cable. Both are available from Comtech EF Data.

See **Figure 4-20** and do these steps to connect the EIA-485 multi-drop cable between the Switch and the modems:

- Connect and secure (1) CA/WR11418-1 EIA-485 terminator on each far-end DB-9F connector of the appropriate EIA-485 multi-drop cable (the standard CA/WR11417-1 shielded cable or the optional CA/RB11423-1 ribbon cable).
- Connect and secure one end of the Null Modem Cable CA/WR11419-1 to the DB-9F connector labeled “485 Pass-Through” on the Switch’s CRS-230 System Controller.
- Connect and secure the EIA-485 multi-drop cable to all CDM-Qx/QxL modems and to the DB-9M connector on the Null Modem Cable.



**Figure 4-20. EIA-485 Multi-drop Cabling Example – CRS-300 to CDM-Qx/QxL  
(Connections shown for RMI and TMIs 1 and 3 only)**

### 4.7.3 Control Y-Cable Connections – CRS-300 to Modems

All traffic data configurations require the Control Y-Cable CA/WR12069-1. Do these steps to connect Switch RMI/TMI(s) and each CDM-Qx/QxL:

- HD-15F connector labeled “J1” on the Switch RMI or TMI(s), to
- DB-15M connectors labeled “Alarms” on each CDM-Qx/QxL modulator and demodulator:
  - J1 of the Control Y-Cable goes to the modulator Alarm connector.
  - J2 of the Control Y-Cable goes to the demodulator Alarm connector.

### 4.7.4 Traffic Data Connections – CRS-300 to Modems

Do these steps to connect and secure the cables between each CDM-Qx/QxL and the Switch:

**If EIA-530 V.35/EIA-232 is the traffic data type**, see **Figure 4-21** and do these steps to connect and secure the Control/Data Cable CA/WR0066:

- DB-25M connector labeled “P2” on the Switch RMI or “P1” on the Switch TMI(s), to
- DB-25F connector labeled “EIA-530” on the CDM-Qx/QxL demodulator.

**If Balanced G.703 is the traffic data type**, see **Figure 4-22** and do these steps to connect and secure the Data Cable CA/WR9038-6:

- DB-15M connector labeled “P1” on the Switch RMI or TMI(s), to
- DB-15F connector labeled “G.703” on the CDM-Qx/QxL demodulator.

**If Unbalanced G.703 is the traffic data type**, see **Figure 4-23** and do these steps to first connect and secure the 75Ω BNC Tx Cable CA/WR0813-8:

- BNC connector labeled “J4” on the Switch RMI or “J3” on the Switch TMI(s), to
- BNC connector labeled “Tx” on the demodulator.

**Next**, do these steps to connect and secure the BNC Rx Cable CA/WR0813-8:

- BNC connector labeled “J3” on the Switch RMI or “J5” on the Switch TMI(s), to
- BNC connector labeled “Rx” on the demodulator.

**If HSSI is the traffic data type**, see **Figure 4-24** and do these steps to connect and secure the HSSI Data Cable CA/WR9189-6:

- HSSI connector labeled “J2” on the Switch RMI or “J3” on the Switch TMI(s), to



- HSSI connector labeled “HSSI” on the demodulator.

**If Quad E1 is the traffic data type**, see **Figure 4-25** and do these steps to first connect and secure the Quad E1 RMI Data Cable CA/WR13018:

- DB-15M connector labeled “P1” on the Switch RMI, to
- (4X) RJ-48 connectors labeled “Port 1” through “Port 4” on the Redundant CDM-Qx/QxL.

**Next**, do these steps to connect and secure the (4X) Quad E1 TMI Data Cables (CEFD P/N PP/CAT5FF7FTGY):

- RJ-48 connectors labeled “Port 1” through “4” on the Switch TMI(s), to
- RJ-48 connectors labeled “Port 1” through “Port 4” on the Traffic CDM-Qx/QxL.

#### **4.7.5 User Data Connections – CRS-300 to User**

You must connect your traffic data from the multiplexing equipment or test data generator to the connectors on the Switch TMI labeled “User Data Interface”. This interface replaces the direct connection to the Traffic Modem’s “Data Interface” connectors.

Because the Redundant Modem’s function is to replace a faulted traffic modem, the Switch RMI does not have a User Data Interface.

See **Sect. 1.4.3.3 Modem Interface Cards** for detailed information on the Switch RMI and TMI cards available for use with the CDM-Qx/QxL modems.

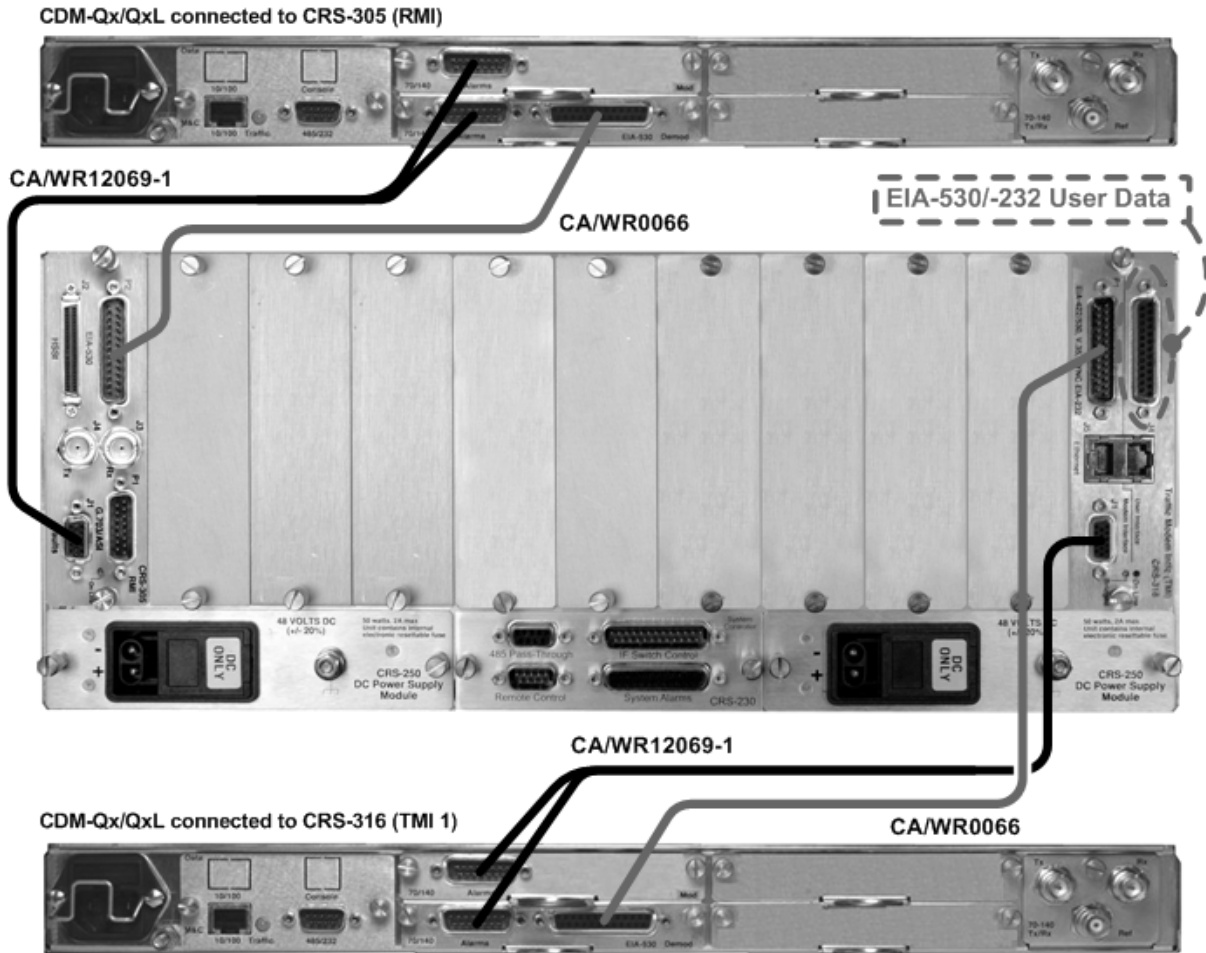
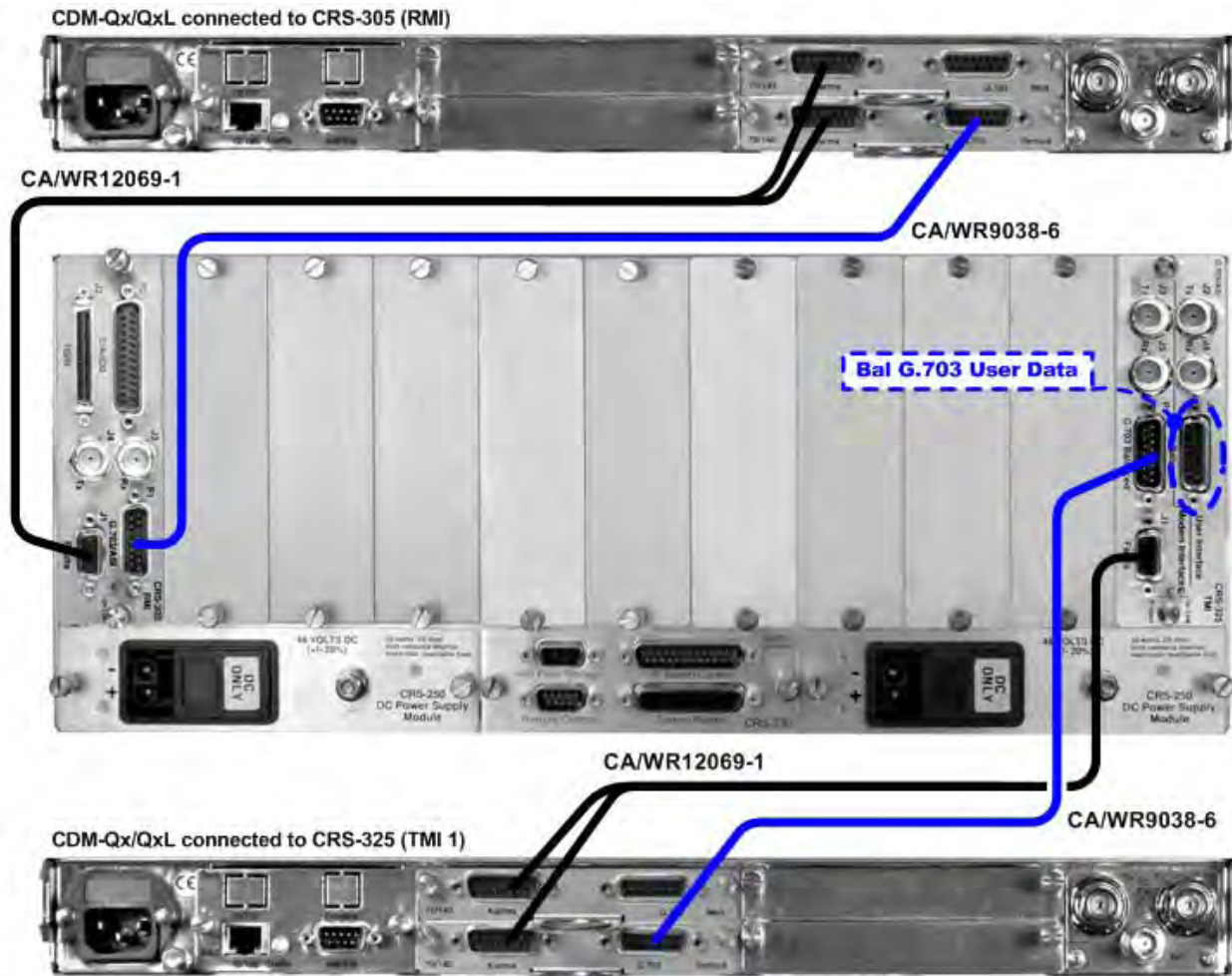
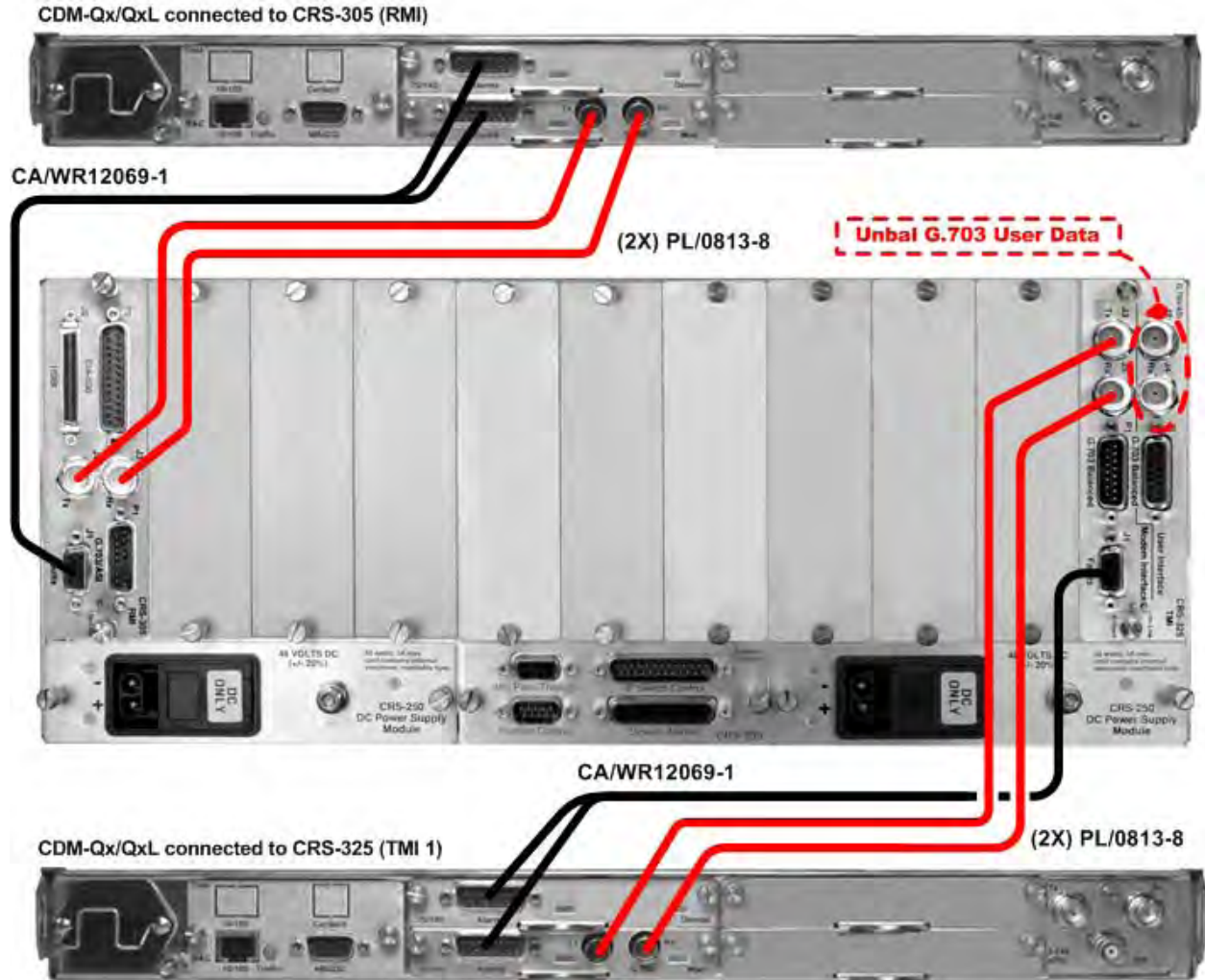


Figure 4-21. Control Y-Cables and EIA-530/-232 Data Cables – CRS-300 to CDM-Qx/QxL  
(Connections shown for RMI and TMI 1 only)

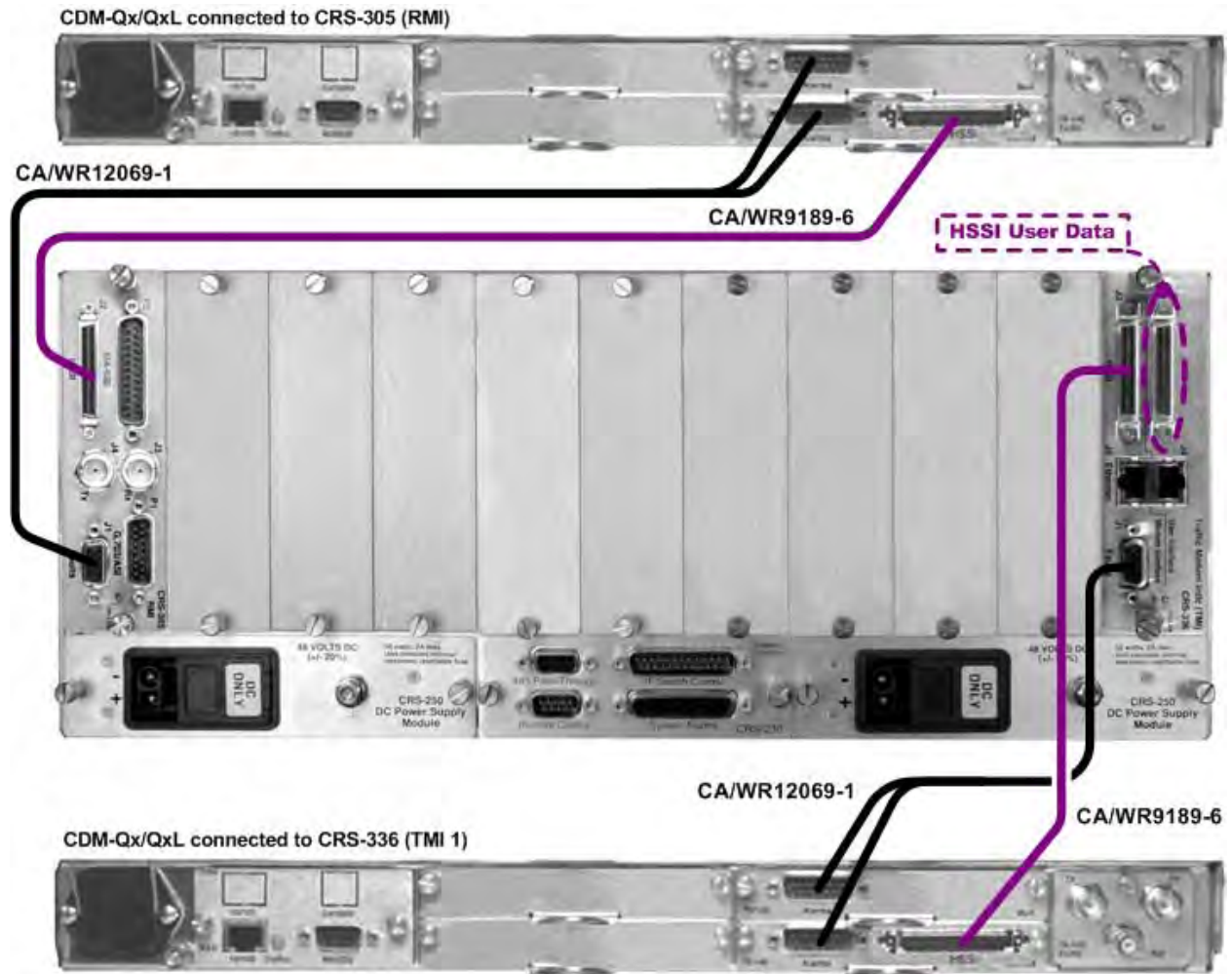


**Figure 4-22. Control Y-Cables and Balanced G.703 Data Cables – CRS-300 to CDM-Qx/QxL**

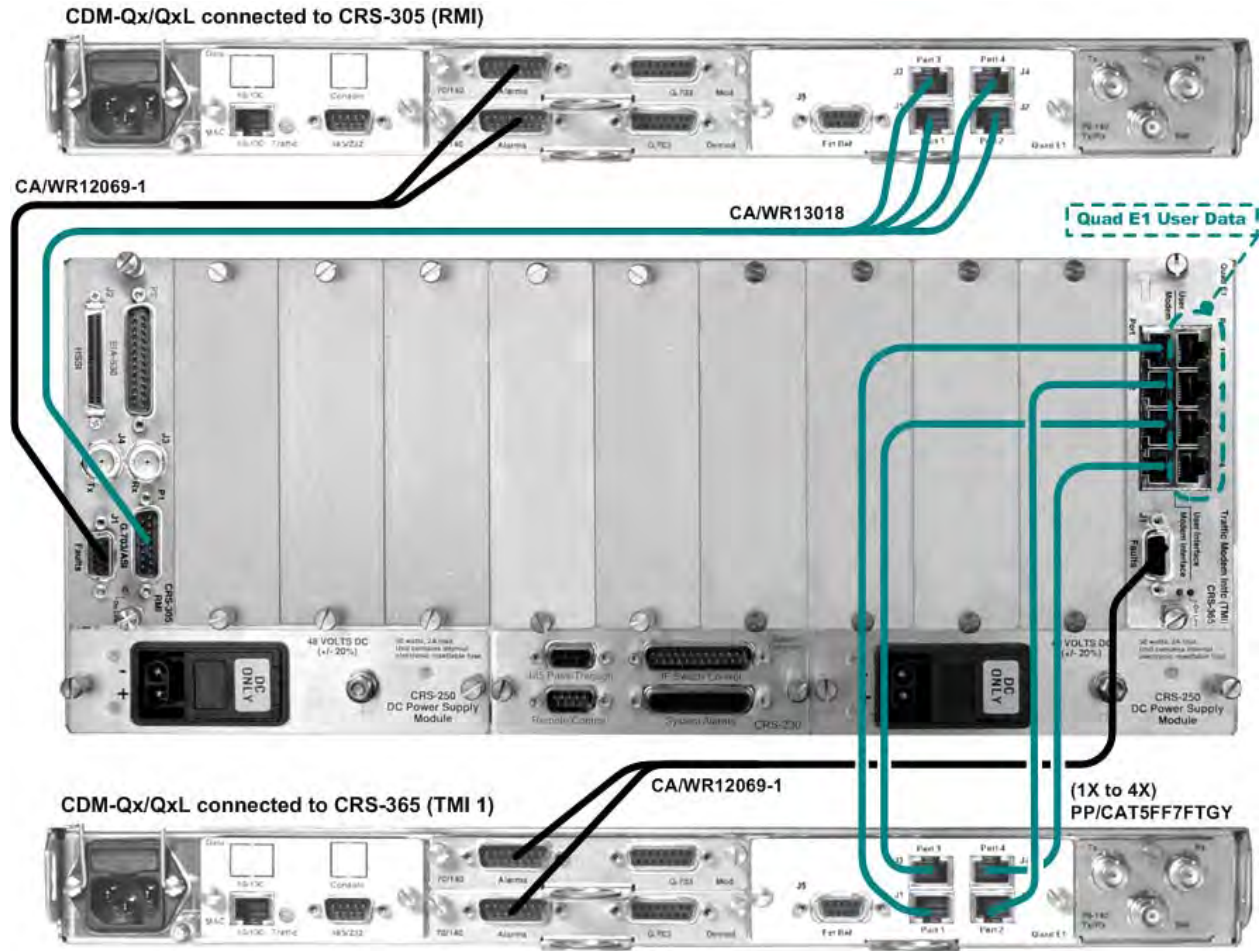
(Connections shown for RMI and TMI 1 only)



**Figure 4-23. Control Y-Cables and Unbalanced G.703 Data Cables – CRS-300 to CDM-Qx/QxL**  
(Connections shown for RMI and TMI 1 only)



**Figure 4-24. Control Cables and HSSI Data Cables – CRS-300 to CDM-Qx/QxL**  
(Connections shown for RMI and TMI 1 only)



**Figure 4-25. Control Cables and Quad E1 Data Cables – CRS-300 to CDM-Qx/QxL  
(Connections shown for RMI and TMI 1 only)**

## **4.8 CDM-710G/710GL Modem Connections**

- **RMI/TMI Limitations and Considerations**
- **Interface Combinations**
- **Control Cable Connections – CRS-300 to Modems**
- **Serial Traffic Data Connections – CRS-300 to Modems**
- **Ethernet Traffic Data Connections – CRS-300 to Modems**
- **User Data Connections – CRS-300 to Users**

## 4.8 CDM-710G/710GL Modem Connections

If adding a modem to an **operating** 1:N system, care needs to be taken not to interfere with the existing traffic. The cabling, power-up sequence and communication connections must be correct to avoid contention in the system from the modem Tx carrier. This information is detailed in **Sect. 6.2.2.5 CONFIG: ACTIVE (Activate Modems)**.

### 4.8.1 RMI/TMI Limitations and Considerations



- 1) **Traffic modems with differing data types are not supported by the Redundant Modem. For example, the Switch can not be populated with Traffic modems with ASI and Traffic modes with HSSI.**
- 2) **Depending on the traffic data type, the appropriate jumper settings are provided on the Switch TMI to ensure proper operation for HSSI with CA/TA signals using the CRS-336 TMI. See Chapter 5. MODEM, TMI, AND SWITCH CONFIGURATION for this important configuration information.**

### 4.8.2 Interface Combinations

The two plug-in interface module slots in the CDM-710G/710GL allow for many possible interface card combinations. **Table 4-2** details the interface card combinations that are compatible with the Switch.

**Table 4-2. CDM-710G/710GL Interface Card Combinations**

CDM-710G/710GL Unit Configuration		1:N CRS-300 Configuration		Notes
Interface Slot 1	Interface Slot 2	TMI Card	RMI Card	
G.703 (CDI-10-1)	None	CRS-325	CRS-306	-
G.703 (CDI-10-1)	GigE (CDI-70)			Can be used as Redundant Unit
HSSI (CDI-60)	None	CRS-336	CRS-306	-
None	GigE (CDI-70)			-
HSSI (CDI-60)	GigE (CDI-70)			Can be used as Redundant Unit

**Notes:**

- 1) The Redundant Modem must have the same interface cards in each slot as any of the Traffic Modems.
- 2) The Traffic Modem must have either the same cards in each slot as any of the other Traffic Modems have, or a blank panel installed.
- 3) **Interface Slots 1 and 2 are not active simultaneously.**



### 4.8.3 Control Cable Connections – CRS-300 to Modems

The Control Cable CA/WR12361-1 provides the serial communication path between the Switch and the modems and controls the modem's external Tx IF-mute control line. **You must always use this cable.**

See **Figure 4-26** and **Figure 4-27** and do these steps to connect and secure the CA/WR12361-1 cables between the Switch and each CDM-710G/710GL:

- HD-15F connector labeled "J1" on the Switch RMI or TMI(s), to
- DB-15M connector labeled "P1 Alarms" on the CDM-710G/710GL.

### 4.8.4 Serial Traffic Data Connections – CRS-300 to Modems

If **G.703** is the traffic data type, see **Figure 4-26** and do these steps to connect and secure the pair of BNC PL/0813-8 cables between the Switch and each CDM-710G/710GL:

- BNC connectors labeled "J4 Tx" on the Switch RMI or "J3 Tx" on the Switch TMI(s) to BNC connectors labeled "Tx J3" on the CDM-710G/710GL's CDI-10-1 plug-in module, to
- BNC connectors labeled "J3 Rx" on the Switch RMI or "J5 Rx" on the Switch TMI(s) to BNC connectors labeled "Rx J2" on the CDM-710G/710GL's CDI-10-1 plug-in module.

If **HSSI** is the traffic data type, see **Figure 4-27** and do these steps to connect and secure the HSSI Data Cable CA/WR9189-6 the Switch and each CDM-710G/710GL:

- HSSI (HD-50F) connector labeled "J2" on the Switch RMI or "J3" on the Switch TMI(s), to
- HSSI (HD-50F) connector labeled "J1 HSSI" on the CDM-710G/710GL's CDI-60 plug-in module.

### 4.8.5 Ethernet Traffic Data Connections – CRS-300 to Modems

To handle Ethernet traffic data, you must route the Ethernet data *through* the Switch like G.703 or HSSI data. This method of processing data through the Switch is referred to as **wired-thru**. For detailed information on this method, see **Appendix A. ETHERNET NETWORK CONFIGURATIONS** in this manual.

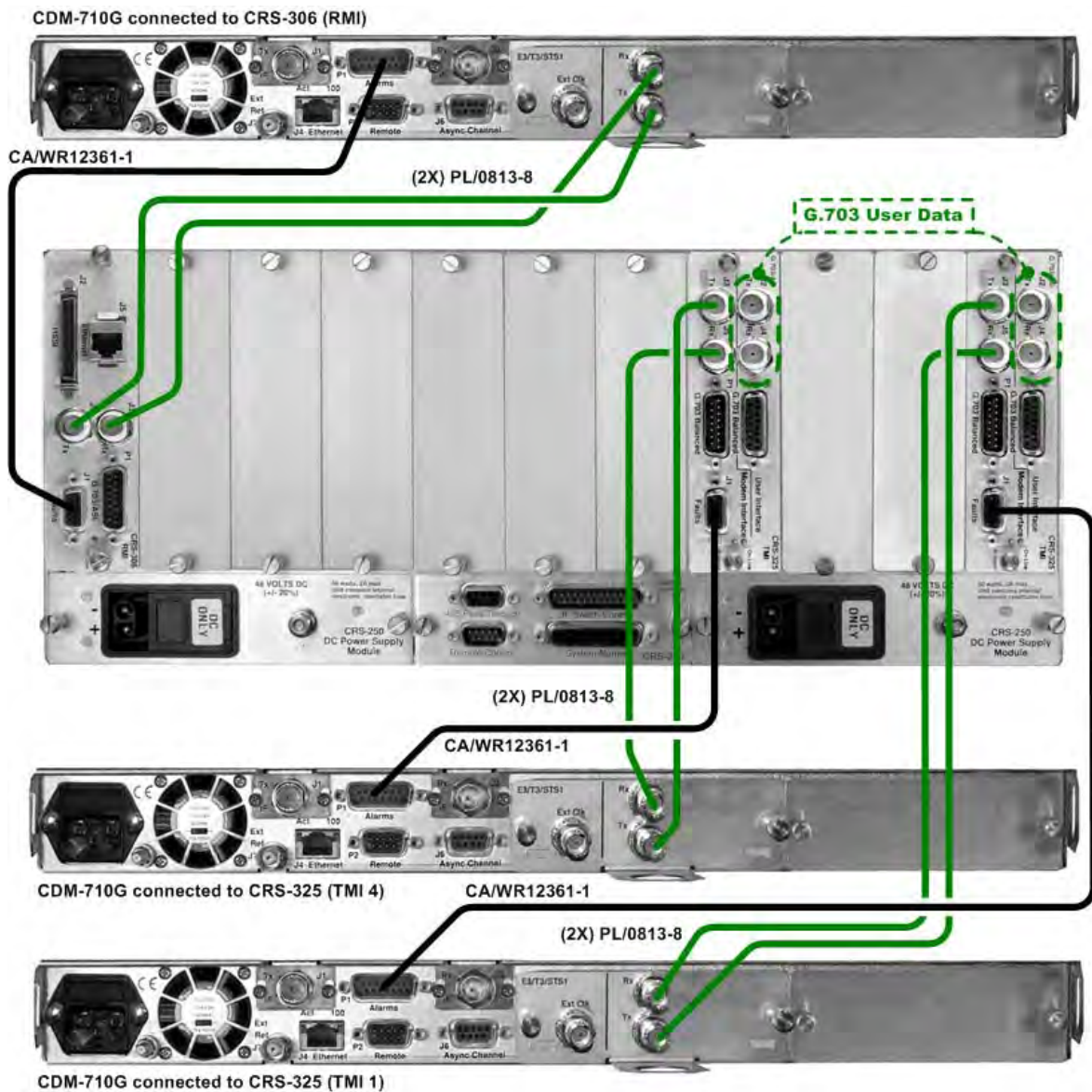
For the wired-thru connection, see **Figure 4-27** and do these steps to connect and secure the CAT5 Data Cable PP/CAT5FF7FTGY (RJ-45 to RJ-45, 7') between the Switch and each CDM-710G/710GL:

- RJ-45 connector labeled "J5" on the Switch RMI or TMI(s), to
- RJ-45 connector labeled "J1" on the CDM-700 (CDI-70) plug-in module.

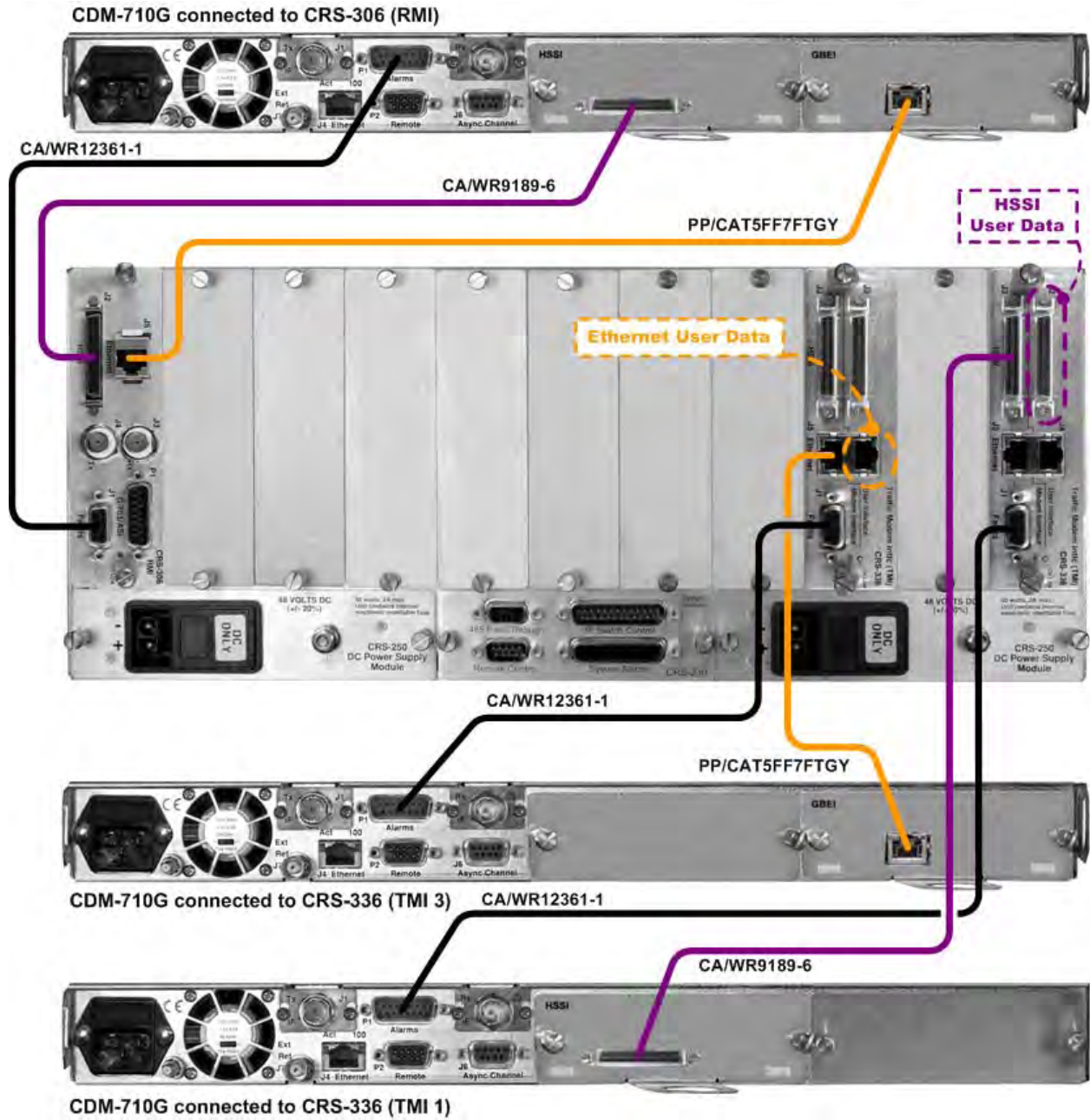
### 4.8.6 User Data Connections – CRS-300 to User

You must connect your traffic from the external router, multiplexing equipment, or test data generator to the connectors on the Switch TMI labeled “User Data Interface”. This interface replaces the direct connection to the Traffic Modem’s “Data Interface” connectors.

Because the Redundant Modem’s function is to replace a faulted Traffic Modem, the Switch RMI does not have a User Data Interface. See **Sect. 1.4.3.3 Modem Interface Cards** for detailed information on the Switch RMI and TMI cards available for use with the CDM-710G/710GL modems.



**Figure 4-26. Control and Data Cables Example #1 – CRS-300 to CDM-710G/710GL**  
(Connections shown for RMI & TMIs 1 and 3 only)



**Figure 4-27. Control and Data Cables Example #2 – CRS-300 to CDM-710G/710GL  
(Connections shown for RMI & TMIs 1 and 3 only)**



## **4.9 CDM-710 Modem Connections**

- **RMI/TMI Limitations and Considerations**
- **Interface Combinations**
- **Control Cable Connections – CRS-300 to Modems**
- **Serial Traffic Data Connections – CRS-300 to Modems**
- **Ethernet Traffic Data Connections – CRS-300 to Modems**
- **User Data Connections – CRS-300 to Users**

## 4.9 CDM-710 Modem Connections

When adding a modem to an **operating** 1:N system, you must take care not to interfere with the existing traffic. The cabling, power-up sequence, and communication connections must be correct to avoid contention in the system from the modem Tx carrier. This information is detailed in **Sect. 6.2.2.5 CONFIG: ACTIVE (Activate Modems)**.

### 4.9.1 RMI/TMI Limitations and Considerations



- 1) **Traffic modems with differing data types are not supported by the Redundant Modem. For example, the Switch can not be populated with Traffic modems with ASI and Traffic modes with HSSI.**
  
- 2) **Depending on the traffic data type, the appropriate jumper settings are provided on the Switch TMI to ensure proper operation for HSSI with CA/TA signals using the CRS-336 TMI. See Chapter 5. MODEM, TMI, AND SWITCH CONFIGURATION for this important configuration information.**

### 4.9.2 Interface Combinations

The two plug-in interface module slots in the CDM-710 allow for many possible interface card combinations. The Switch can cover many of these combinations, but not all – capability is limited by the Switch’s backplane configuration. For example, if you configure the Switch backplane to handle one HSSI interflow, then this limits the supported Redundant and Traffic modems to one HSSI interface per unit as well. **Table 4-3** details the CDM-710 interface card combinations that are compatible with the Switch.

**Table 4-3. CDM-710 Interface Card Combinations**

CDM-710 Modem Configuration		1:N CRS-300 Configuration		Notes
Interface Slot 1	Interface Slot 2	TMI Card	RMI Card	
ASI (CDI-40)	None	CRS-325	CRS-306	-
ASI (CDI-40)	GbE (CDI-70)			Can be used as Redundant Modem
HSSI (CDI-60)	None	CRS-336	CRS-306	-
None	GbE (CDI-70)			-
HSSI (CDI-60)	GbE (CDI-70)			Can be used as Redundant Modem

**Notes:**

- 1) The Redundant Modem must have the same interface cards in each slot as any of the Traffic Modems.
  
- 2) The Traffic Modem must have either the same interface cards in each slot as any of the other Traffic Modems have, or a blank panel installed.
  
- 3) **Interface Slots 1 and 2 are not active simultaneously.**

### 4.9.3 Control Cable Connections – CRS-300 to Modems

The Control Cable CA/WR12361-1 provides the serial communication path between the Switch and the modems and controls the modem's external Tx IF-mute control line. **You must always use this cable.**

See **Figure 4-28** and **Figure 4-29** and do these steps to connect and secure the CA/WR12361-1 cables between the Switch and each CDM-710:

- HD-15F connector labeled "J1" on the Switch RMI or TMI(s), to
- DB-15M connector labeled "P1 Alarms" on the CDM-710.

### 4.9.4 Serial Traffic Data Connections – CRS-300 to Modems

**If ASI is the traffic data type**, see **Figure 4-28** and do these steps to connect and secure the pair of BNC PL/0813-8 cables between the Switch and each CDM-710:

- BNC connectors labeled "J4 Tx" on the Switch RMI or "J3 Tx" on the Switch TMI(s) to BNC connectors labeled "Tx J4" on the CDM-710's CDI-40 plug-in module, to
- BNC connectors labeled "J3 Rx" on the Switch RMI or "J5 Rx" on the Switch TMI(s) to BNC connectors labeled "Rx J2" on the CDM-710's CDI-40 plug-in module.

**If HSSI is the traffic data type**, see **Figure 4-29** and do these steps to connect and secure the HSSI Data Cable CA/WR9189-6 between the Switch and each CDM-710:

- HSSI (HD-50F) connector labeled "J2" on the Switch RMI or "J3" on the Switch TMI(s), to
- HSSI (HD-50F) connector labeled "J1 HSSI" on the CDM-710's CDI-60 plug-in module.

### 4.9.5 Ethernet Traffic Data Connections – CRS-300 to Modems

To handle Ethernet traffic data, you must route the Ethernet data *through* the Switch like G.703 or HSSI data. This method of processing data through the Switch is referred to as **wired-thru**. For detailed information on this method, see **Appendix A. ETHERNET NETWORK CONFIGURATIONS** in this manual.

For the wired-thru connection, see **Figure 4-29** and do these steps to connect and secure the CAT5 Data Cable PP/CAT5FF7FTGY (RJ-45 to RJ-45, 7') between the Switch and each CDM-710:

- RJ-45 connector labeled "J5" on the Switch RMI or TMI(s), to
- RJ-45 connector labeled "J1" on the CDM-700 (CDI-70) plug-in module.

### 4.9.6 User Data Connections – CRS-300 to User

You must connect your traffic data from the external router, multiplexing equipment, or test data generator to the connectors on the Switch TMI labeled “User Data Interface”. This interface replaces the direct connection to the Traffic Modem’s “Data Interface” connectors.

Because the Redundant Modem’s function is to replace a faulted Traffic Modem, the Switch RMI does not have a User Data Interface. See **Sect. 1.4.3.3 Modem Interface Cards** for detailed information on the Switch RMI and TMI cards available for use with the CDM-710 modems.

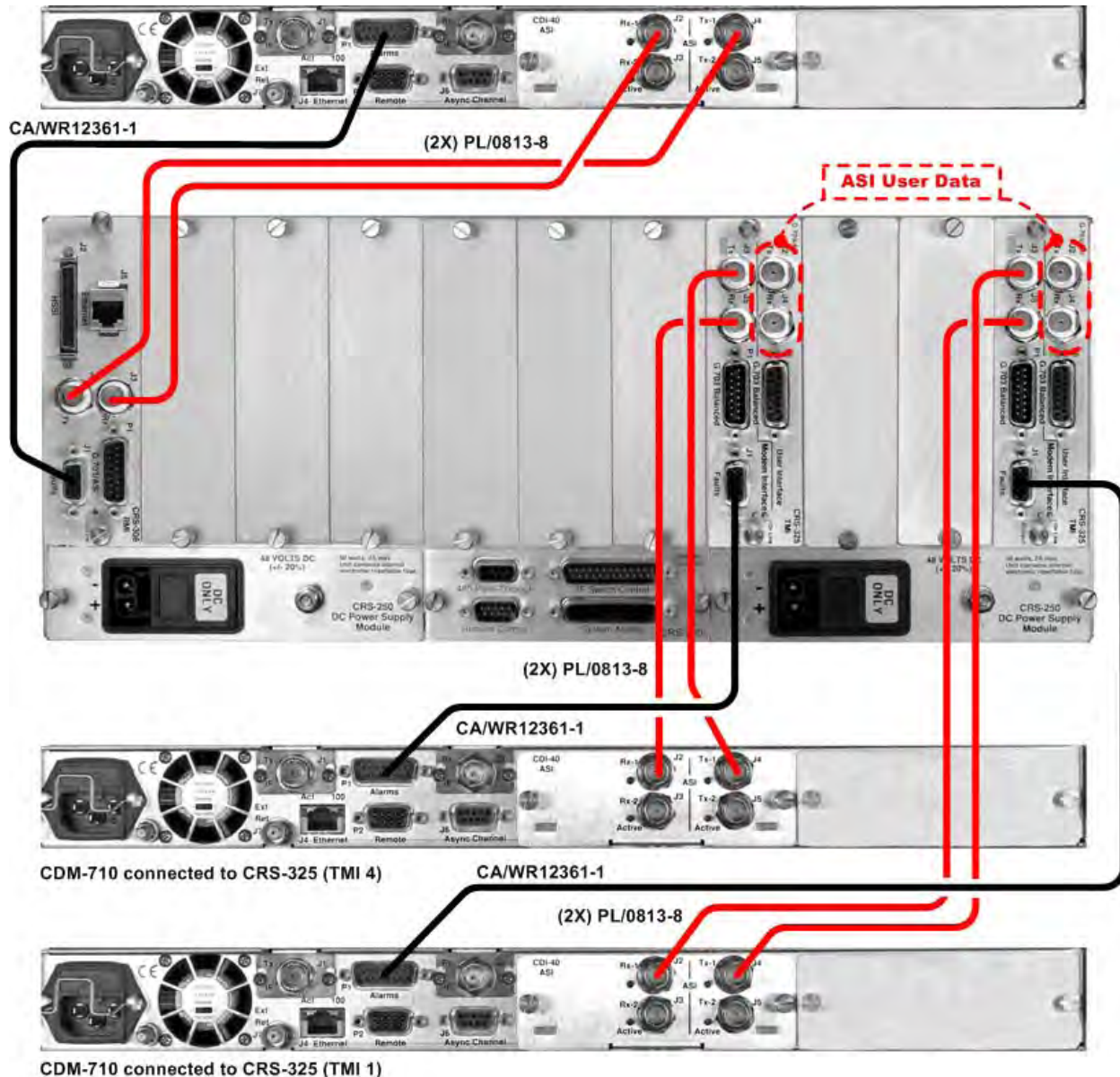
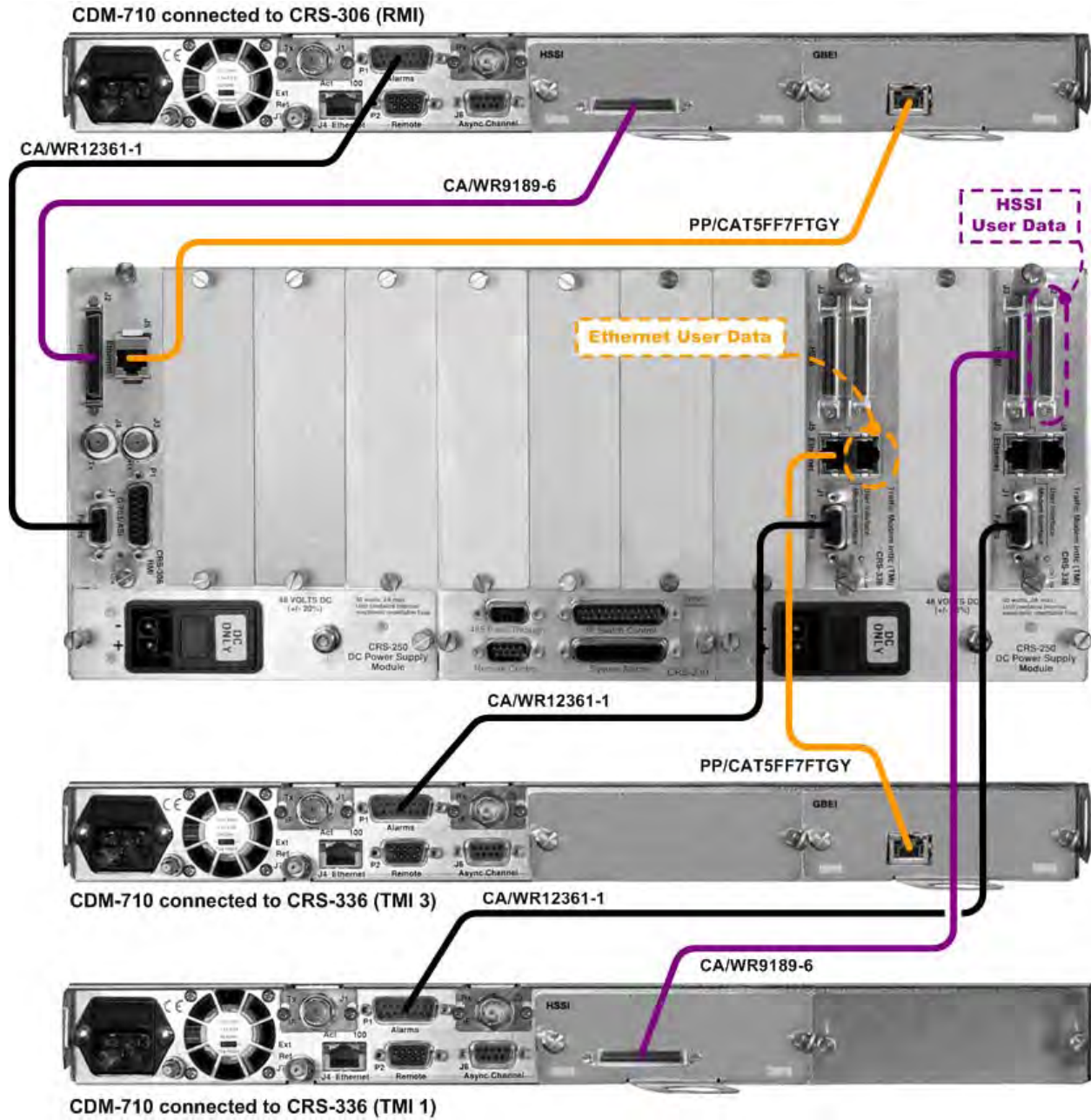


Figure 4-28. Control and Data Cables Example #1 – CRS-300 to CDM-710  
(Connections shown for RMI & TMIs 1 and 3 only)





**Figure 4-29. Control and Data Cables Example #2 – CRS-300 to CDM-710  
(Connections shown for RMI & TMIs 1 and 3 only)**



## **4.10 CDM-700 Modem Connections**

- **RMI/TMI Limitations and Considerations**
- **Interface Combinations**
- **Control Cable Connections – CRS-300 to Modems**
- **Serial Traffic Data Connections – CRS-300 to Modems**
- **Ethernet Traffic Data Connections – CRS-300 to Modems**
- **Wired-thru Connections**
- **Wired-around Connections**
- **User Data Connections – CRS-300 to Users**

## 4.10 CDM-700 Modem Connections

If adding a modem to an **operating** 1:N system, care needs to be taken not to interfere with the existing traffic. The cabling, power-up sequence and communication connections must be correct to avoid contention in the system from the modem Tx carrier. This information is detailed in **Sect. 6.2.2.5 CONFIG: ACTIVE (Activate Modems)**.

### 4.10.1 RMI/TMI Limitations and Considerations



- 1) **Traffic modems with differing data types can all be supported by the Redundant Modem.**
- 2) **Depending on the traffic data type, the appropriate jumper settings are provided on the Switch TMI to ensure proper operation for HSSI with CA/TA signals using the Switch CRS-336 TMI. See Chapter 5. MODEM, TMI, AND SWITCH CONFIGURATION for this important configuration information.**

### 4.10.2 Interface Combinations

The two plug-in interface module slots available in the CDM-700 allow for many possible interface card combinations. The Switch can cover many, but not all, of these combinations.

**Table 4-4** details the CDM-700 interface card combinations that are compatible with the Switch.

**Table 4-4. CDM-700 Interface Card Combinations**

CDM-700 Modem Configuration		1:N CRS-300 Configuration		Comments
Interface Slot 1	Interface Slot 2	TMI Card	RMI Card	
G.703 (CDI-10)	None	CRS-345	CRS-306	---
	G.703 (CDI-10)	CRS-345	CRS-306	---
	HSSI (CDI-60)	Not Supported	Not Supported	Exceeds backplane capability
	GbE (CDI-70)	CRS-345	CRS-306	Use wired-around GigE (see APPENDIX A)
OC3 Copper (CDI-50)	None	CRS-325	CRS-306	---
	GbE (CDI-70)			Valid for Redundant modem
HSSI (CDI-60)	None	CRS-336	CRS-306	---
	HSSI (CDI-60)	None	None	Exceeds backplane capability
	GbE (CDI-70)	CRS-336	CRS-306	Use wired-around GigE (see APPENDIX A)
GbE (CDI-70)	None	CRS-336	CRS-306	---
	GbE (CDI-70)			Use wired-around GigE (see APPENDIX A)
None	G.703 (CDI-10)	CRS-345	CRS-306	---
	HSSI (CDI-60)	CRS-336		---
	GbE (CDI-70)			---

**Notes:**

- 1) The Redundant CDM-700 must have either the same cards in each slot as any of the Traffic CDM-700s.
- 2) The Traffic CDM-700 must have either the same cards in each slot as any of the other Traffic CDM-700s have, or a blank panel installed.
- 3) An OC-3 Optical TMI is not currently available.
- 4) As of April 2007:
  - The CRS-336 TMI card replaces the CRS-335.
  - The CRS-306 RMI card replaces the CRS-305.

### 4.10.3 Control Cable Connections – CRS-300 to Modems

The Control Cable CA/WR12361-1 provides the serial communication path between the Switch and the modems and controls the modem's external Tx IF-mute control line. **You must always use this cable.**

See **Figure 4-30** and **Figure 4-31** and do these steps to connect and secure the CA/WR12361-1 cables between the Switch and each CDM-700:

- HD-15F connector labeled "J1" on the Switch RMI or TMI(s), to
- DB-15M connector labeled "P1 Alarms" on the CDM-700.

### 4.10.4 Serial Traffic Data Connections – CRS-300 to Modems

If **G.703** is the traffic data type, see **Figure 4-30**, **Figure 4-31**, **Figure 4-33**, or **Figure 4-35** and do these steps to connect and secure the Traffic Data Cables CA/RF12278-1 and CA/RF12279-1 between the Switch and each CDM-700:

**First**, do these steps to connect and secure the CA/RF12279-1 cable between the Switch and the Redundant CDM-700:

- DB-15M connector labeled "P1" on the Switch RMI, to
- BNC connectors (four connectors per installed CDI-10 card) on the Redundant CDM-700 (depending on the modem configuration, either <4X> or <8X> BNC connectors are used).

**Next**, do these steps to connect and secure the CA/RF12278-1 cables between the Switch and the Traffic CDM-700(s):

- DB-9M connector labeled "P1" on the Switch TMI(s), to

- BNC connectors (four connectors per installed CDI-10 card) on each Traffic CDM-700 (depending on the modem configuration, either <4X> or <8X> BNC connectors are used).

**If HSSI is the traffic data type**, see **Figure 4-31** and **Figure 4-34** and do these steps to connect and secure the HSSI Data Cable CA/WR9189-6 between the Switch and each CDM-700:

- HSSI (HD-50F) connector labeled “J2” on the Switch RMI, or “J3” on the Switch TMI(s), to
- HSSI (HD-50F) connector labeled “HSSI” on each CDM-700.

**If OC-3 copper is the traffic data type**, see **Figure 4-32** and do these steps to connect and secure the pair of BNC PL/0813-8 cables between the Switch and each CDM-700:

- BNC connectors labeled "J4 Tx" on the Switch RMI, or "J3 Tx" on the Switch TMI(s), to BNC connectors labeled "Tx" on the CDM-700's CDI-50 plug-in module, and
- BNC connectors labeled "J3 Rx" on the Switch RMI, or "J5 Rx" on the Switch TMI(s), to BNC connectors labeled "Rx" on the CDM-700's CDI-50 plug-in module.

#### 4.10.5 Ethernet Traffic Data Connections – CRS-300 to Modems

You have two choices for handling Ethernet traffic data:

- If the Traffic Modem uses Ethernet as the sole traffic data type, then you must route the Ethernet data *through* the Switch like G.703 or HSSI data. This is known as the **wired-thru** method for processing data through the Switch.
- If the Traffic Modem uses Ethernet plus another data type like G.703 or HSSI, then the Ethernet data can be routed *around* the Switch. This is known as the **wired-around** method for processing data around the Switch.



#### Appendix A. ETHERNET NETWORK CONFIGURATIONS

##### 4.10.5.1 Wired-thru Connections

**For the wired-thru connection method**, see **Figure 4-32** and **Figure 4-33**. Do these steps to connect and secure the CAT5 Data Cable PP/CAT5FF7FTGY between the Switch and each CDM-700:

- RJ-45 connector labeled “J5” on the Switch RMI or TMI(s), to
- RJ-45 connector labeled “J1” on the CDM-700 (CDI-70) plug-in modules.

##### 4.10.5.2 Wired-around Connections

**For the wired-around connection method**, see **Figure 4-34** and **Figure 4-35**. Do these steps to connect and secure the CAT5 Data Cable PP/CAT5FF7FTGY for each CDM-700:

- RJ-45 connector labeled “J1” on the CDM-700 (CDI-70) plug-in module, to
- RJ-45 connector on the user-provided Ethernet switch

#### 4.10.6 User Data Connections – CRS-300 to User

You must connect your traffic data from the external router, multiplexing equipment, or test data generator to the connectors on the Switch TMI labeled “User Data Interface”. This interface replaces the direct connection to the Traffic CDM-700’s “Data Interface” connectors.

If you choose the **wire-around method** for Ethernet traffic, your traffic interface will be on the user-provided switch.

Because the Redundant CDM-700’s function is to replace a faulted Traffic CDM-700, the Switch RMI does not have a User Data Interface.

See **Sect. 1.4.3.3 Modem Interface Cards** for detailed information on the Switch RMI and TMI cards available for use with the CDM-700 modems.

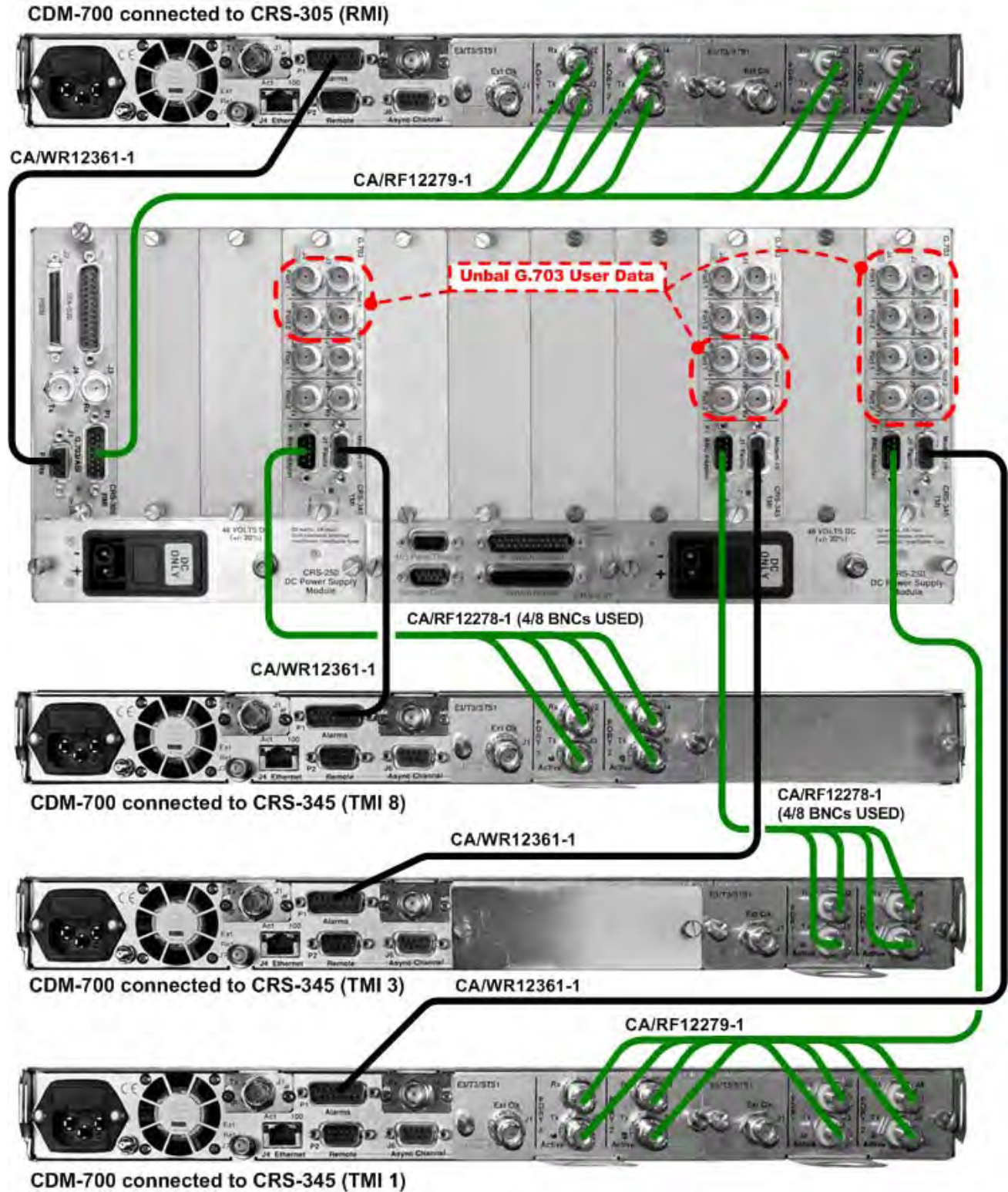


Figure 4-30. Control and Traffic Data Cables Example #1 – CRS-300 to CDM-700  
(Connections shown for RMI and TMIs 1, 3, and 8 only)



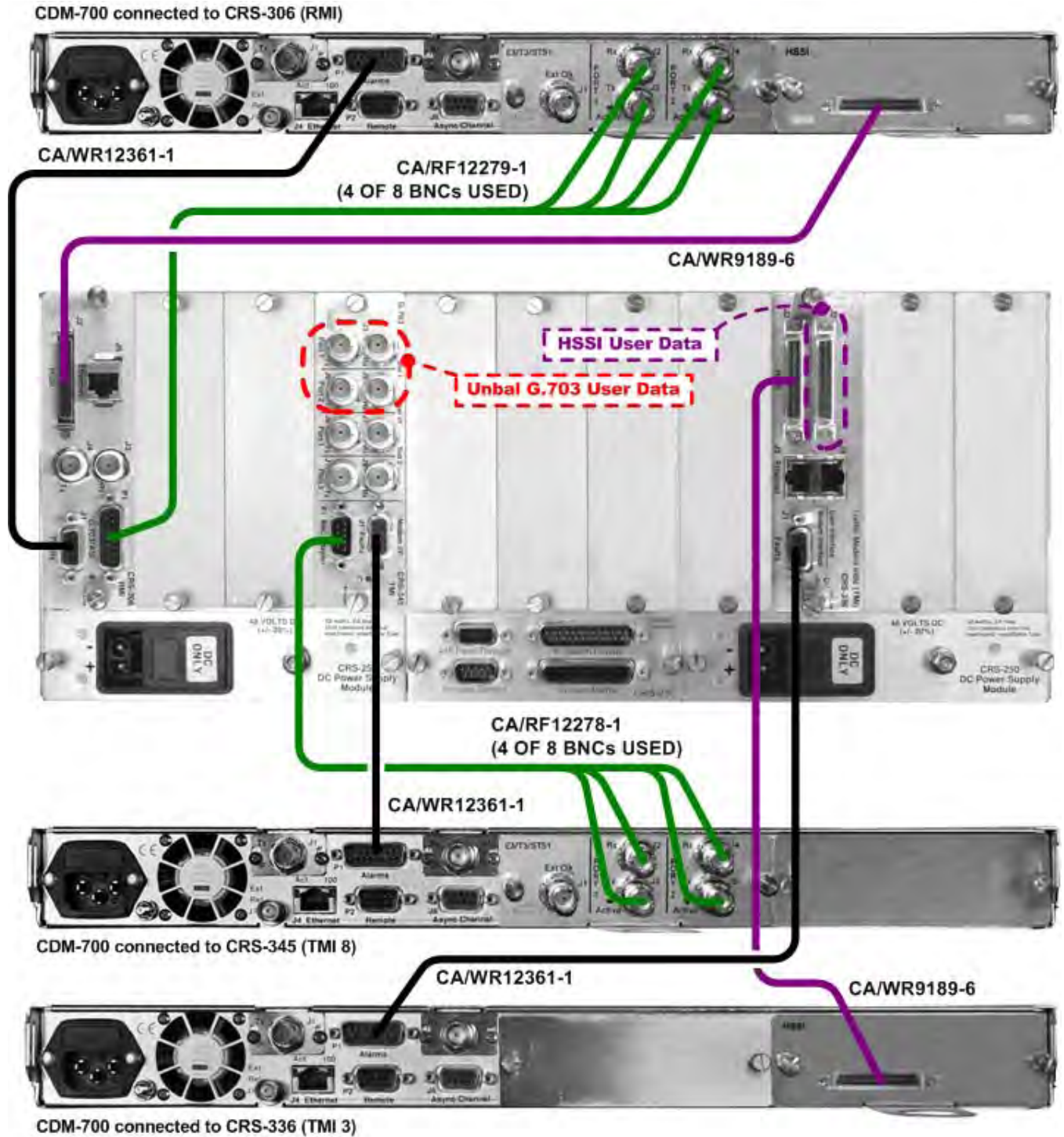
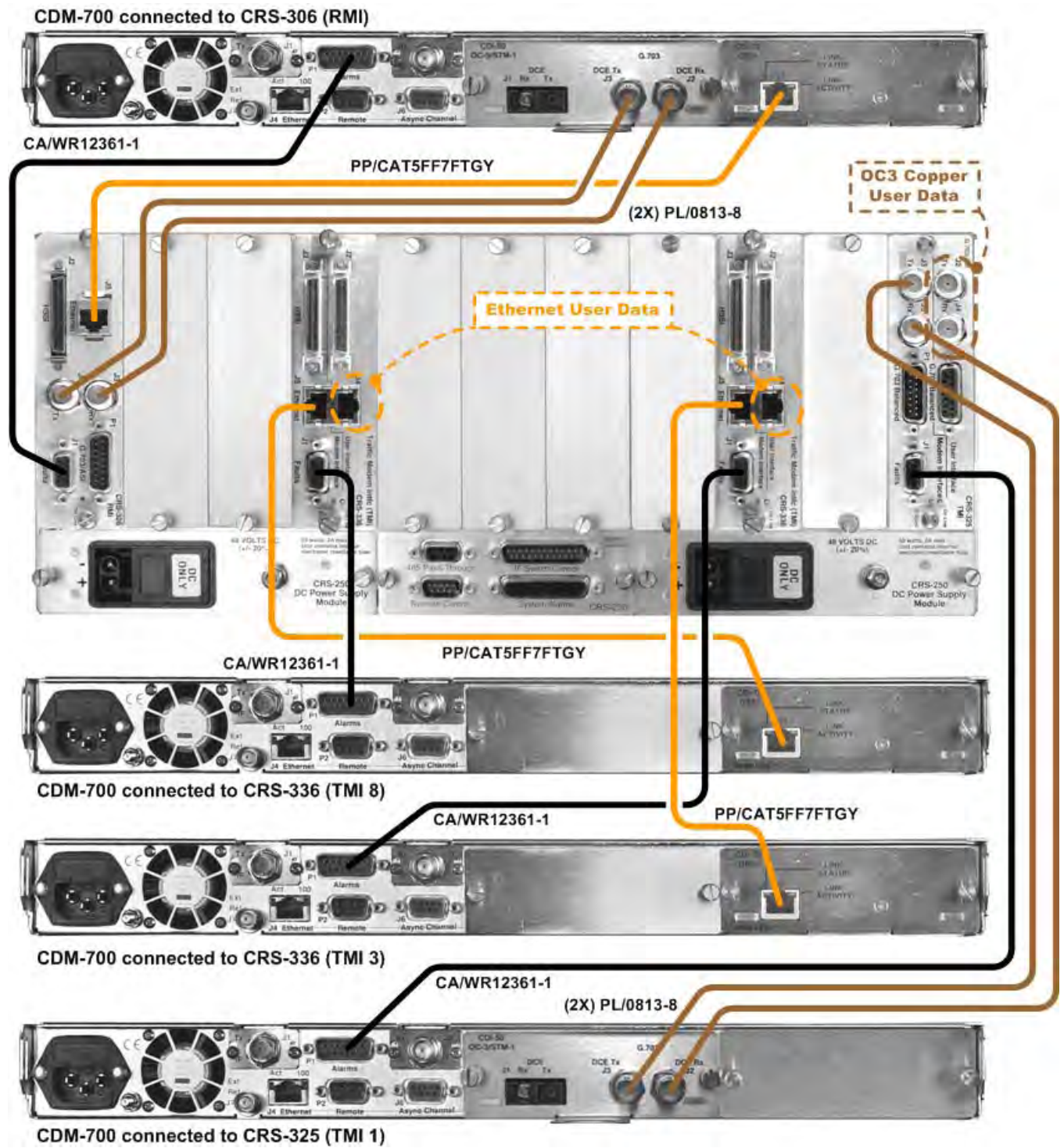
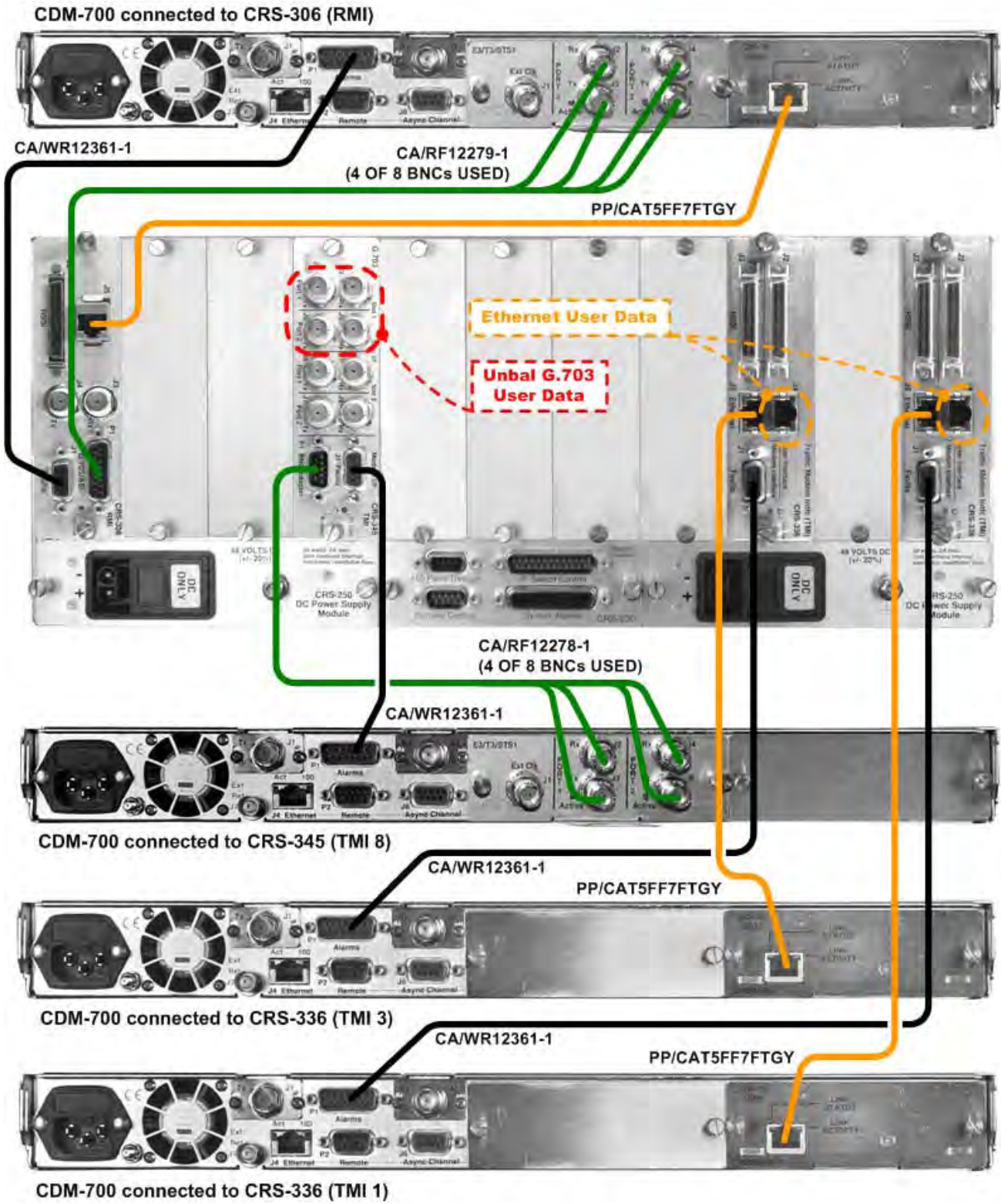


Figure 4-31. Control and Traffic Data Cables Example #2 – CRS-300 to CDM-700  
(Connections shown for RMI and TMIs 3 and 8 only)



**Figure 4-32. CDM-700 IP Connections – Wired-thru Example #1**  
(Connections shown for RMI and TMIs 1, 3, and 8 only)



**Figure 4-33. CDM-700 IP Connections – Wired-thru Example #2**  
(Connections shown for RMI and TMIs 1, 3, and 8 only)

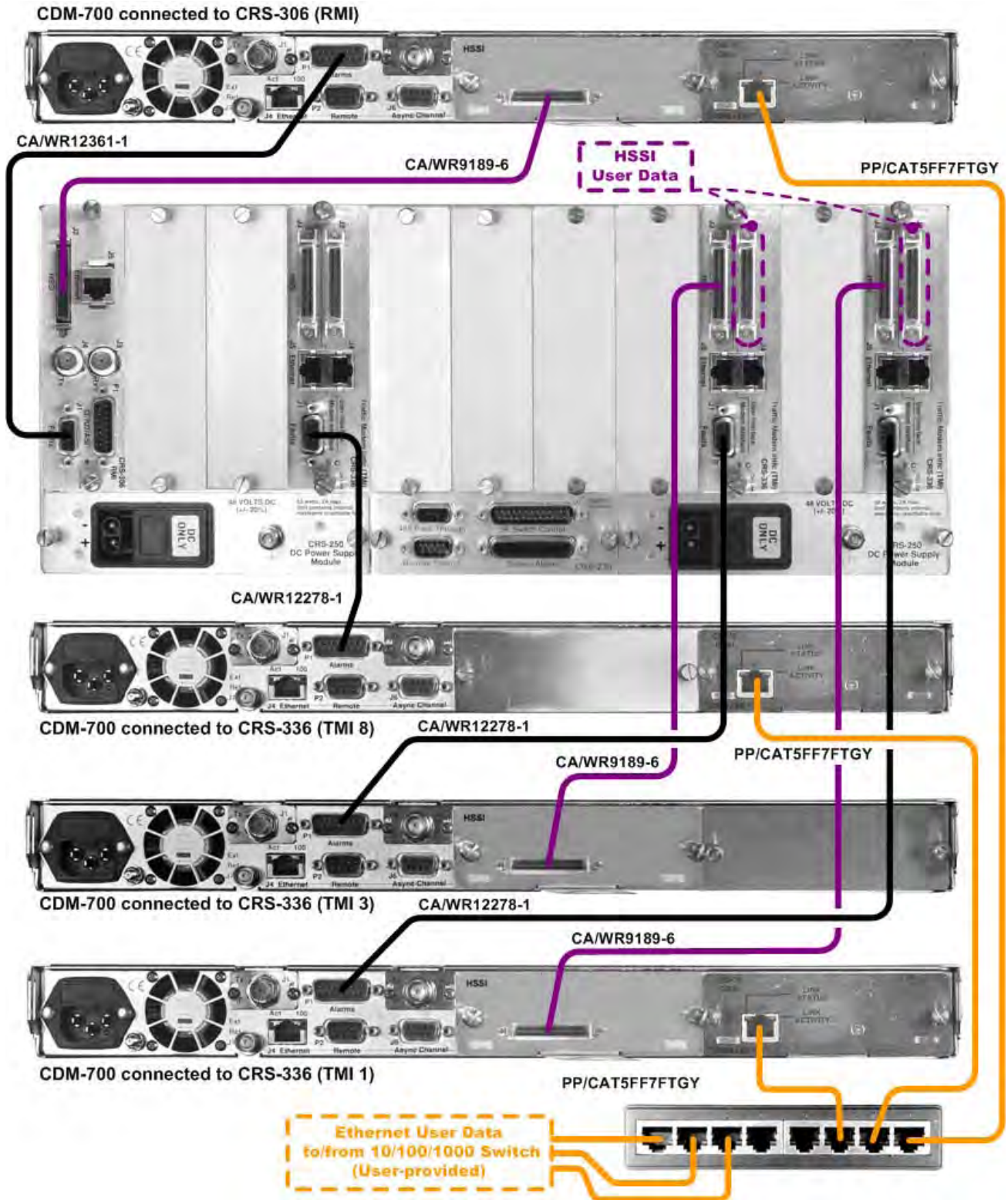
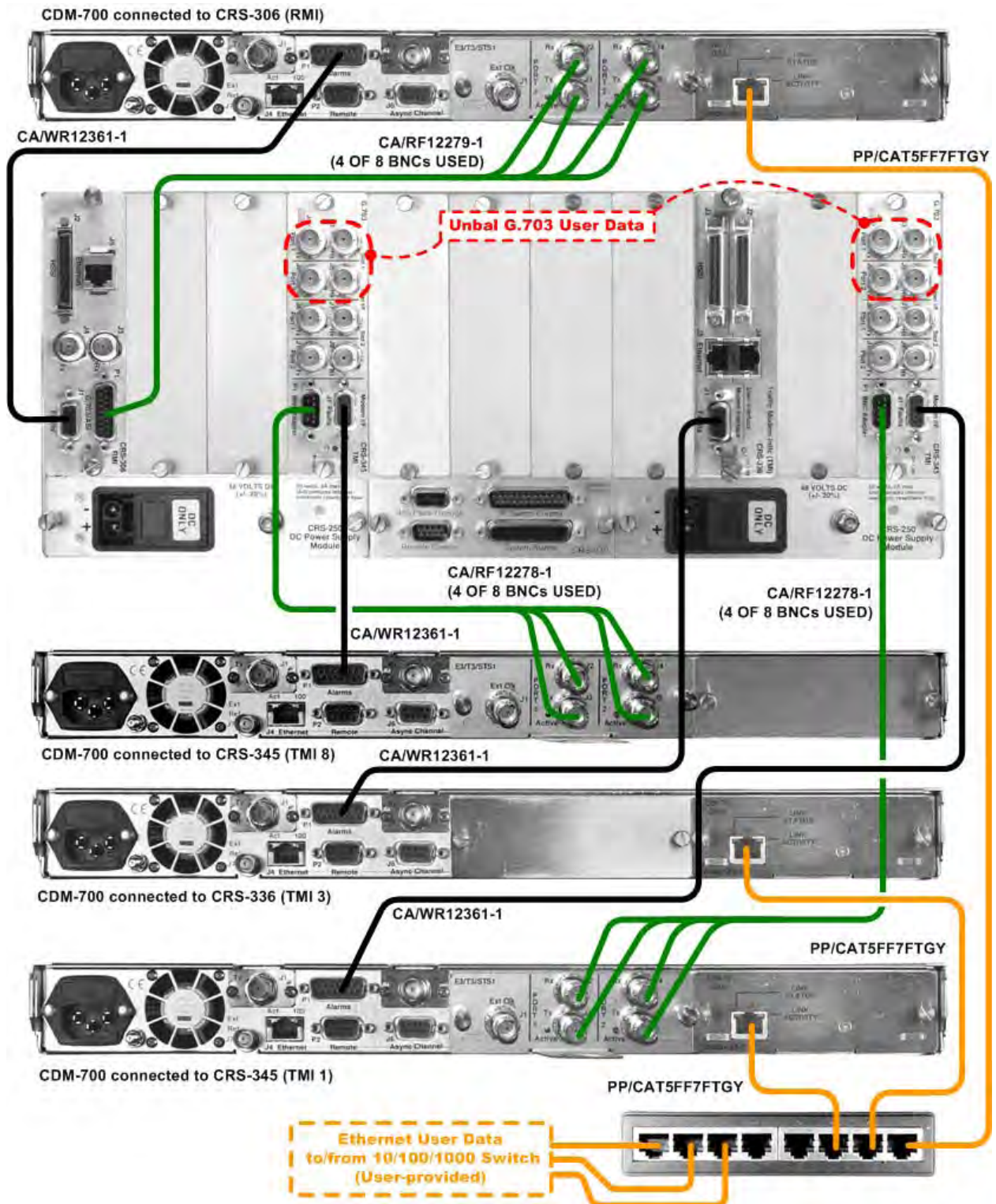


Figure 4-34. CDM-700 IP Connections – Wired-around Example #1  
(Connections shown for RMI and TMIs 1, 3, and 8 only)



**Figure 4-35. CDM-700 IP Connections – Wired-around Example #2**  
(Connections shown for RMI and TMIs 1, 3, and 8 only)



## 4.11 CDM-600/L Modem Connections



The CDM-625 and CDM-625A Advanced Satellite Modems, with available CDM-600 Emulator Mode, serve as operationally transparent replacement units for the CDM-600/L Open Network Satellite Modems.

- **Control and Data Connections – CRS-300 to Modems**
- **User Data Connections – CRS-300 to User**
- **ESC Data Connections – CRS-350 to Modems**
- **User ESC Data Connections – CRS-350 to User**

---

## 4.11 CDM-600/L Modem Connections

If adding a modem to an **operating** 1:N system, care needs to be taken not to interfere with the existing traffic. The cabling and power-up sequence must be correct to avoid contention in the system from the modem Tx carrier. This sequence is described in **Sect. 6.2.2.5 CONFIG: ACTIVE (Activate Modems)**.



**Traffic modems with differing data types can all be supported by the Redundant Modem.**

### 4.11.1 Control and Data Connections – CRS-300 to Modems



See **Sect. 1.4.3.3 Modem Interface Cards** for detailed information on the Switch RMI and TMI cards available for use with the CDM-600/L modems.

The 25-pin Control/Data Cable CA/WR0066 provides the EIA-422/-232/LVDS traffic data path and serial communication path between the Switch and the modems. Therefore, you must always use this cable, even when the data type is G.703.



**The Switch TMIs feature jumpers that are pre-set to ensure proper operation with the following traffic data:**

- For **EIA-422** RTS/CTS, DTR/DSR signals using the **CRS-340**
- For **HSSI** with CA/TA signals using the **CRS-370**

See **Chapter 5. MODEM, TMI, AND SWITCH CONFIGURATION** for this important configuration information.

See **Figure 4-36** and do these steps to connect and secure the CA/WR0066 cables between the Switch and each CDM-600/L:

- DB-25M connector labeled “P1” on the Switch RMI or TMI(s), to
- DB-25F connector labeled “P3B Data Interface” on the CDM-600/Ls.

**If G.703 is the traffic data type**, also do these steps to connect the CA/WR9038-6 data cable, which you must use for either Balanced or Unbalanced G.703 **Data**:

- DB-15M connector labeled “P2” on the Switch RMI or TMI(s), to
- DB-15F connectors labeled “P7 Balanced G.703” on the CDM-600/Ls.



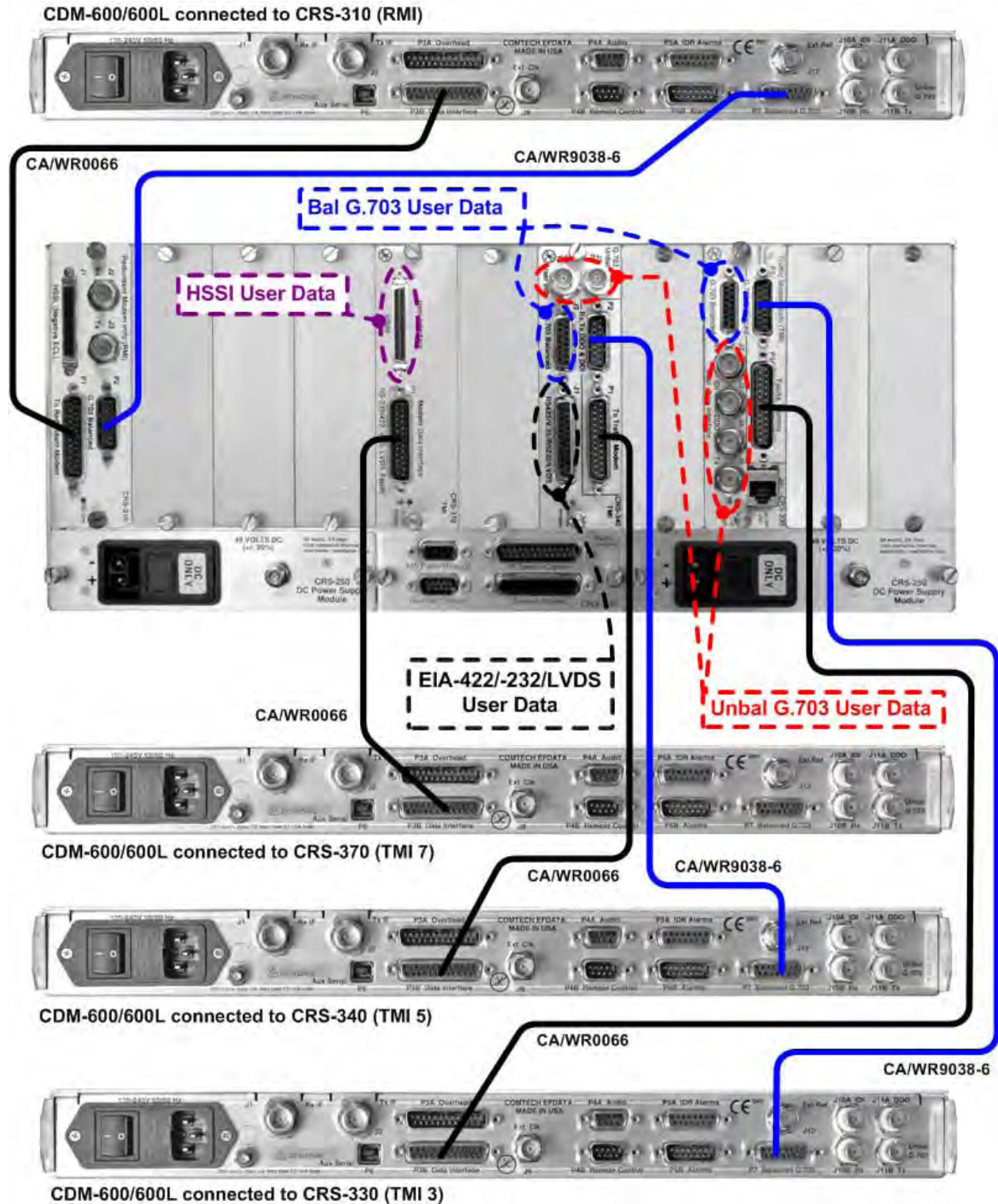


Figure 4-36. Data Cable Connection Example – CRS-300 to CDM-600/L  
(Connections shown for RMI and TMIs 1, 3, 5, and 7 only)

## 4.11.2 User Data Connections – CRS-300 to User

You must connect your traffic data from the multiplexing equipment or a test data generator to the connectors labeled “User Data Interface” on the Switch TMI(s). This interface replaces the direct connection to the Traffic Modem’s “Data Interface” connectors.



- 1) **Because the Redundant Modem’s function is to replace a faulted Traffic Modem, the Switch RMI does not have a User Data Interface.**
- 2) **Ensure that you correctly configure modem operation for Balanced or Unbalanced G.703 data.**

**For T1/E1 operation**, the optional CN-0000268 T1/E1 Adapter (see **Figure B-32** in **Appendix B. CABLE DRAWINGS**) may be purchased from Comtech EF Data to adapt the Balanced G.703 DB-15F connector on the User Data side of the Switch TMI to a RJ-48 female connection.

## 4.11.3 ESC Data Connections – CRS-350 to Modems

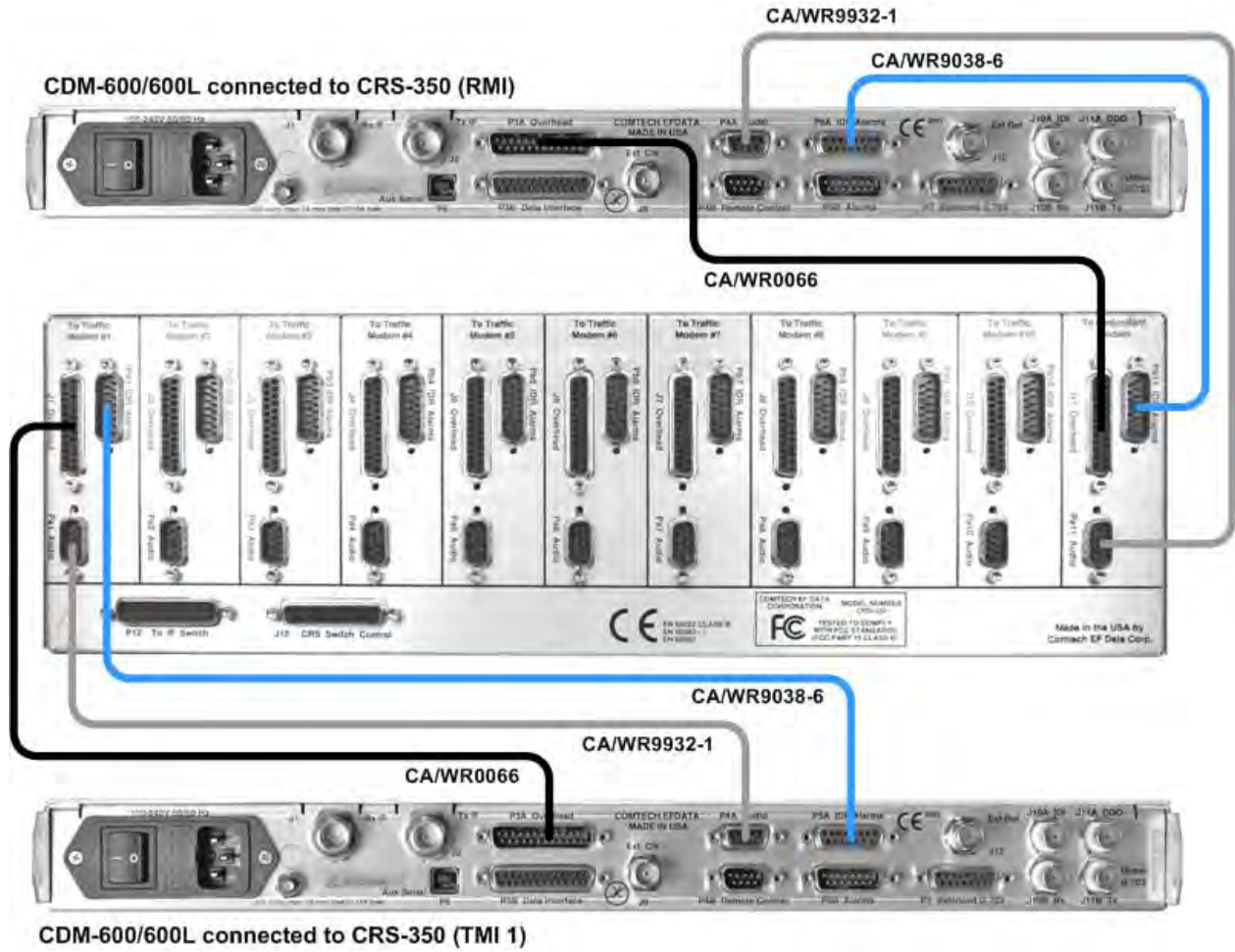
See **Figure 4-37** and do these steps to connect and secure the cables between the CRS-350 and each CDM-600/L modem:

- Connect and secure the CA/WR0066 cable:
  - DB-25F connector on the CRS-350, to
  - DB-25M connectors labeled “P3A Overhead” on the CDM-600/L.
- Connect and secure the CA/WR9038-6 cable:
  - DB-15M connector on the CRS-350, to
  - DB-15F connectors labeled “P5A IDR Alarms” on the CDM-600/L.
- Connect and secure the CA/WR9932-1 cable:
  - DB-9M connector on the CRS-350, to
  - DB-9F connectors labeled “P4A Audio” on the CDM-600/L.

## 4.11.4 User ESC Data Connections – CRS-350 to User

You must connect your equipment to the correct corresponding plug-in module on the CRS-350 front panel. This replaces the direct connection to the Traffic Modem’s “IDR”, “Audio” and “Overhead” ports. See **Figure 1-24** in **Sect. 1.5 CRS-350 ESC Switch Description** for detailed information on this interface.

Because the Redundant Modem’s function is to replace a faulted Traffic Modem, the Switch RMI does not have a User Data Interface.



**Figure 4-37. Cabling Example for CRS-350 to CDM-600/L  
(Connections shown for RMI and TMI 1 only)**



# Chapter 5. MODEM, RMI/TMI, AND SWITCH CONFIGURATION

---

## 5.1 Overview



In order to avoid damage to both the Switch and the modems, it is important that you do these steps, in sequence:

- First, mount the Switch and all modems as instructed in [Chapter 2. INSTALLATION](#).
- Next, connect your control, IF, and traffic data cabling between the **powered OFF** modems and the Switch as instructed in [Chapter 4. CABLES AND CONNECTIONS](#). *Leave the Switch and all modems powered off until all connections are ready.*
- Then, configure your modems for 1:N redundant operation as instructed in this chapter in [Sect. 5.2 Configure Your Modems](#).
- Then, if needed, configure your Switch RMI/TMI cards as instructed in this chapter in [Sect. 5.3 RMI Card Configuration Reference](#) and [Sect. 5.4 TMI Card Configuration Reference](#).
- Finally, once you properly configure the modems and Switch RMI/TMI cards for 1:N redundant operation, you should then set the Switch for proper operation using the CRS-300 Front Panel, as instructed in this chapter in [Sect. 5.5. Configure the CRS-300 Switch](#).

## 5.2 Configure Your Modems

### 5.2.1 Connect Your Modem Power

Connect the power cords of each modem to a power supply and turn all modems **ON**.

### 5.2.2 Modem Firmware and Hardware Requirements

All Traffic Modems and the Redundant Modem must be of the same model in order for the CRS-300 1:10 Redundancy Switch to operate correctly. You must also configure the Redundant Modem with the same firmware version and installed options as the Traffic Modems, so that it can properly mimic all installed Traffic Modems in the event of switchover.

Permitted modem models and firmware versions are:

Modem	Modem Firmware Version	GigE Firmware Version
CDM-625	1.1.1 or later	N/A
CDM-625A	1.1.1 or later	N/A
CDM-570	1.4.1 or later	N/A
CDM-570A	1.1.1 or later	N/A
CDM-570L	1.3.1 or later	N/A
CDM-570AL	1.1.1 or later	N/A
CDM-Qx/QxL	1.1.4 or later	N/A
CDM-710G/710GL	5.1.1. or later	1.1.9
CDM-710	4.1.1 or later	1.1.3
CDM-700	1.2.1, 1.2.4 or later ( <b>Note:</b> When using GigE, F/W Ver. 1.2.3 is <b>not</b> compatible with the Switch)	1.1.9
CDM-600	1.1.5 or later	N/A
CDM-600L	1.1.1 or later	N/A

**SLM5650/5650A Firmware and Hardware Requirements:** In order to support the desired redundancy, you must load the appropriate firmware into the SLM-5650/5650A base modem, Network Processor (if applicable), and Switch. Higher versions of the firmware continue support for the given interface (i.e. the highest version supports all interfaces).

The lowest firmware versions that you require to support a given interface type are:

Interface Type	SLM-5650 Base Modem	SLM-5650A Base Modem	10/100/1000 Base-T (GbE) Interface card	Network Processor Module	CRS-300
Serial (EIA-232/HSSI)	1.2.4	1.1.1	N/A	N/A	2.1.7
Ethernet (Single-port Ethernet Bridge Mode using 10/100/1000 Base-T card)	1.2.4	1.1.3	1.1.2	N/A	2.1.7
Ethernet (Single-port Ethernet Bridge Mode using Port 1 of 4-port NP Module)	1.5.1	1.1.8	N/A	1.5.1	2.1.7

### 5.2.2.1 Update Your Modem Firmware

Comtech EF Data ships its products with the latest version of operating firmware. If you need to update your modem firmware, you may download the update from the Comtech EF Data Web site ([www.comtechedata.com](http://www.comtechedata.com)). You may also receive the firmware update archive file via e-mail from Comtech EF Data Product Support.

For detailed instructions on updating your modems to their latest operating firmware, see the pertinent modem's *Installation and Operation Manual*.

### 5.2.3 Configure Your Modem Operation



**Make sure to operate your modem with its latest available firmware and hardware configuration. Hardware revision upgrades must be performed at Comtech EF Data. Contact Comtech EF Data Product Support for assistance if the modem does not meet the operational requirements listed in this manual.**

This chapter assumes user familiarity with the menu navigation and configuration parameter selection methods using the pertinent modem front panel menu. For detailed instructions on changing configuration settings using the front panel keypad and menus, see the *Front Panel Operation* chapter in your modem's *Installation and Operation Manual*.

Use your modem manual to configure each Traffic Modem for the proper Rx and Tx IF, power settings, modulation, code rates, and traffic data settings.

For User-to-Switch or User-to-Modem addressing schemes, see **Appendix C. ADDRESSING SCHEME INFORMATION**.

### 5.2.4 Configure Your Modems for 1:N Redundancy

#### 5.2.4.1 Configure Switch-to-CDM-625/A 1:N Redundancy

The Switch communicates to the Redundant and Traffic modems via a serial COMM bus contained within each of the DB-25 or HD-15 control/data cables.

Typical for each modem:

**First**, use the CDM-625/A Font Panel menu to configure the COMMS (make sure to press **ENTER** to save your changes):

**Select: Configuration → Remote → Remote Control = Remote → RS-232 → set baud rate to 9600**

**Then**, use the CDM-625/A Font Panel menu to configure the CDM-625/A for 1:N Redundancy (make sure to press **ENTER** to save your changes). Do these steps:

Step	Task
1	Configure the DB-25 “Data” connector on the modem rear panel for “Redundancy Mode”. On each modem, set “1:N” redundancy to the <b>Active</b> state:  <b>Select: Utility → 1:N → Enable,Disable → set to Enable</b>
2	<b>Power down</b> all CDM-625/As.
3	<b>Power up</b> all CDM-625/As. Verify that front panel LEDs indicate that each Traffic Modem is <b>ONLINE</b> .

### 5.2.4.1.1 Configure CDM-625/A 1:N Redundancy for Carrier-in-Carrier®

If you use **Carrier-in-Carrier® (CnC)** with any CDM-625/A traffic modem, special configuration steps must be taken to make sure proper operation of the modem(s) within a configured 1:N Redundancy System.

Before you make any configurations changes, see **Figure 4-8** and the instructions found in **Section 4.4.2** in **Chapter 4. CABLES AND CONNECTIONS** to connect and secure the CA-0000275 PMSI Multi-drop CnC Plus Cable (<11X> DB-9M, 8.25') between the Redundant Modem and all other Traffic Modem(s) using CnC.



**The CA-0000275 cable bypasses the CRS-300 1:10 Redundancy Switch.**

Once you interconnect all CnC-enabled modems with the PMSI Multi-drop Cable, you must then configure each CnC-enabled modem. Use the CDM-625/A Front Panel menu to do these steps (make sure to press **ENTER** to save your changes):

- **First**, from the top-level **Select:** menu – use the ◀▶ arrow and **ENTER** keys to navigate each nested menu level until the PMSI control mode display screen appears:

**Select: Configuration → CnC → PMSI-control**

```
Select: Configuration Test Monitor
Info Store/Ld Utility ODU FAST ( ◀ ▶ )
```

```
CONFIG: All Mode Tx Rx Clocks D&I
CnC EDMAC Misc Mask Remote IP ( ◀ ▶ )
```

```
Carrier-in-Carrier: Mode Freq-Offset
Search-Delay PMSI-control ( ◀ ▶ )
```

```
CnC PMSI mode: Redundancy
(Idle, Redundancy, Talk, Listen) ( ⚡ )
```

- **Then**, from the **PMSI mode** display screen – use the ▲▼ arrow keys to select **Redundancy**, and then press **ENTER**.





**You must repeat this configuration step for every CnC-enabled CDM-625/A within the configured redundancy system.**

The **Pre-Mapped Symbol Interface (PMSI)** is an EIA-485 multi-drop bus system where one device transmits, and all other devices on the multi-drop bus are configured to receive. PMSI function, as associated with DoubleTalk® Carrier-in-Carrier®, permits the modulator in a selected unit to provide a direct copy of its output (the outbound interferer) to one or many other modems. The other modem(s) may then choose to take the PMSI signal and use it for its own CnC reference.

### 5.2.4.2 Configure Switch-to-CDM-570/A, CDM-570L/AL, CDM-600/L 1:N Redundancy

Configure the COMMS for each of the modems via the *modem* front panel menu (note that the menus specify the obsolete Recommended Standard (RS) designation – e.g., RS-232 – rather than the current Electronic Industries Association (EIA) designation – e.g., EIA-232):

**Select: Configuration → REMOTE: RS-232, 9600 baud, format 8-N-1**

Make sure to press **ENTER** to save your changes.

### 5.2.4.3 Configure Switch-to-SLM-5650/5650A 1:N Redundancy

#### 5.2.4.3.1 Configure TTL (Switch) (for All Traffic Data Types)

The Switch communicates with the SLM-5650/5650A Redundant and Traffic modems via a serial TTL bus contained within the HD-15 “J9 | Auxiliary” connector on the modem rear panel. An HD-15M to HD-15F Control Cable connects each modem to the Switch.

To use 1:N Redundancy, you must configure the SLM-5650/5650A communications to TTL (Switch) in order to communicate with the Switch. Use the SLM-5650/5650A Front Panel menu to set the serial interface (make sure to press **ENT** to save your changes). Do these steps:

Step	Task
1	Use the ◀ ▶ arrow keys to select the nested <b>Select: Configuration → Remote → SerialConfig</b> menu. <ul style="list-style-type: none"> <li>• Set the <b>Interface</b> to <b>TTL (SWITCH)</b>.</li> <li>• Set the <b>Format</b> to <b>8N1</b></li> <li>• Set the <b>Baudrate</b> to <b>9600 Baud</b></li> </ul>
2	Press <b>ENT</b> to save your changes.
3	Verify that Traffic Modem is <b>ONLINE</b> and the Redundant Modem is <b>OFFLINE</b> .



**See Chapter 5. FRONT PANEL OPERATION in the *SLM-5650 or SLM-5650A Installation and Operation Manual* for detailed information about using the modem front panel menus.**

### 5.2.4.3.2 Configure Ethernet Bridge Mode via Optional Network Processor (NP) Interface

Due to backplane limitations, the Switch supports **Single-port Ethernet Bridge Mode** only. Ethernet Bridge Mode redundancy, when using SLM-5650/5650A modems equipped with the optional Network Processor (NP) Interface, is provided by a single IP Address scheme.

Typical for each **Online Modem** – use the SLM-5650/5650A Front Panel menu to verify Single IP Address Mode (make sure to press **ENT** to save your changes). Do these steps:

Step	Task
1	Use the ◀ ▶ arrow keys to select the nested <b>Select: CONFIG → Remote → EthernetConfig → Option Card Addr → Network Proc</b> menu.
2	Verify that the <b>AddrMode</b> is set to <b>Single</b> .

Then, for the **Offline Modem** – use the SLM-5650/5650A Front Panel menu to verify Single IP Address Mode (make sure to press **ENT** to save your changes). Do these steps:

Step	Task
1	Use the ◀ ▶ arrow keys to select the nested <b>Select: CONFIG → Remote → EthernetConfig → Option Card Addr → Network Proc</b> menu.
2	Set the <b>Traffic IP</b> Address of the <b>Online Modem</b> <i>only</i> .
3	Verify that the <b>Traffic IP</b> Address also appears on the <b>Offline Modem</b> .

In Ethernet Bridge Mode, the Switch keeps the Online Modem’s active Ethernet Port turned **on**, while the Offline Modem’s active Ethernet Port is turned **off**. The traffic IP Address is only accessible on the Online Modem.

Furthermore, the parameter backup mechanism is unsupported in Ethernet Bridge Mode. You must therefore make sure that all parameters match in the Online and Offline modems.



See Chapter 5. **FRONT PANEL OPERATION** in the *SLM-5650 or SLM-5650A Installation and Operation Manual* for detailed information about using the modem front panel menus.

### 5.2.4.3.3 Configure Ethernet Bridge Mode via Optional GbE Interface

The Switch supports **Single-port Ethernet Bridge Mode** only due to backplane limitations. Ethernet Bridge Mode redundancy, when using SLM-5650/5650 modems equipped with the optional 10/100/1000 Base-T (GbE) Interface, is provided by a Single IP Address scheme.

You must configure the SLM-5650/5650A for Ethernet Bridge Mode redundancy. Typical for each modem – use the SLM-5650/5650A Front Panel menu to enter a unique IP Address for the optional 10/100/1000 Base-T (GbE) Interface card that is on the same subnet. Make sure to press **ENT** to save your changes:

**Select: CONFIG → Mode → Interface → Gigabit Ethernet**



See Chapter 5. FRONT PANEL OPERATION in the *SLM-5650 or SLM-5650A Installation and Operation Manual* for detailed information about using the modem front panel menus.

### 5.2.4.4 Configure Switch-to-CDM-Qx/QxL 1:N Redundancy

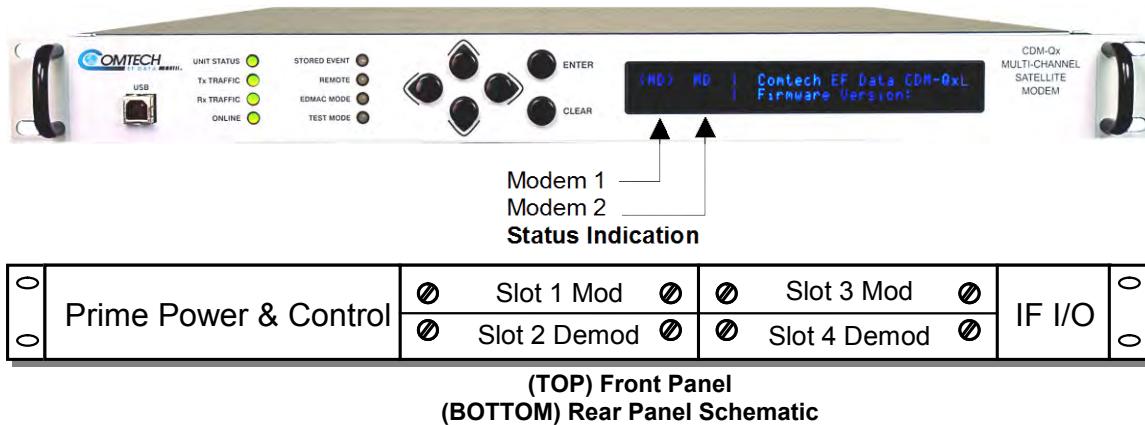
The Switch-to-CDM-Qx/QxL redundancy configuration uses an external EIA-485 multi-drop communication cable.

You can configure the CDM-Qx/QxL in many different ways – i.e., one-to-four modulators, one-to-four demodulators, a mix of one or more modems, etc. For a Switch application, you should configure the CDM-Qx/QxL only as **one** modem consisting of one modulator card and one demodulator card; the pair must be **grouped** to act as a single modem.



See the *CDM-Qx/QxL Installation and Operation Manual* for detailed configuration information.

As shown in **Figure 5-1**, Modem 1 resides in Slots 1 and 2. Slots 3 and 4 comprise Modem 2. The Switch can use either modem.



**Figure 5-1. CDM-Qx/QxL Serial Communication Configuration Example**

The CDM-Qx/QxL chassis has a configurable EIA-485 base address, applicable to Modem 1, and an offset that is added to the base-address when addressing Modem 2 or greater. You must use the CDM-Qx/QxL Front Panel menu to select the EIA-485 addresses (identified on the menus as RS-485). Use the ◀▶ arrow keys to select **CONFIG** → **REMOTE**. Make sure to press **ENTER** to save your changes.


The Switch address for each CDM-Qx/QxL Traffic Modem is based on which TMI it is attached to, with addresses specified in increments of 100.

**For example** – for a Switch with address 0, the CDM-Qx/L on TMI 1 is assigned address 0100; the TMI 2 address is 0200, and so forth, up to address 1000 for TMI 10.



It is important that you understand the addressing scheme before proceeding. The RMI uses address 1100.

Typical for each modem – use the CDM-Qx/QxL Front Panel menu to configure the COMMS (make sure to press **ENT** to save your changes). Do these steps:

Step	Task
1	Use the ◀ ▶ arrow keys to select the nested <b>Config: Remote → SerialConfig</b> menu: <ul style="list-style-type: none"><li>• Set <b>Interface</b> to <b>RS-485-4W</b></li><li>• Set <b>Format</b> to <b>8N1</b>.</li><li>• Set <b>Baudrate</b> to <b>9600</b> Baud.</li></ul>
2	Press <b>ENT</b> to save your serial configuration settings.
3	 <b>See Figure 5-2 and Appendix C. Addressing Scheme Information for instructions on setting up the EIA-485 (RS-485) base address and offset.</b>



In this example, the EIA-485 offset address does not affect Modem #1, so the offset can be 0001 to 0099 without affecting other Modems' EIA-485 addresses.

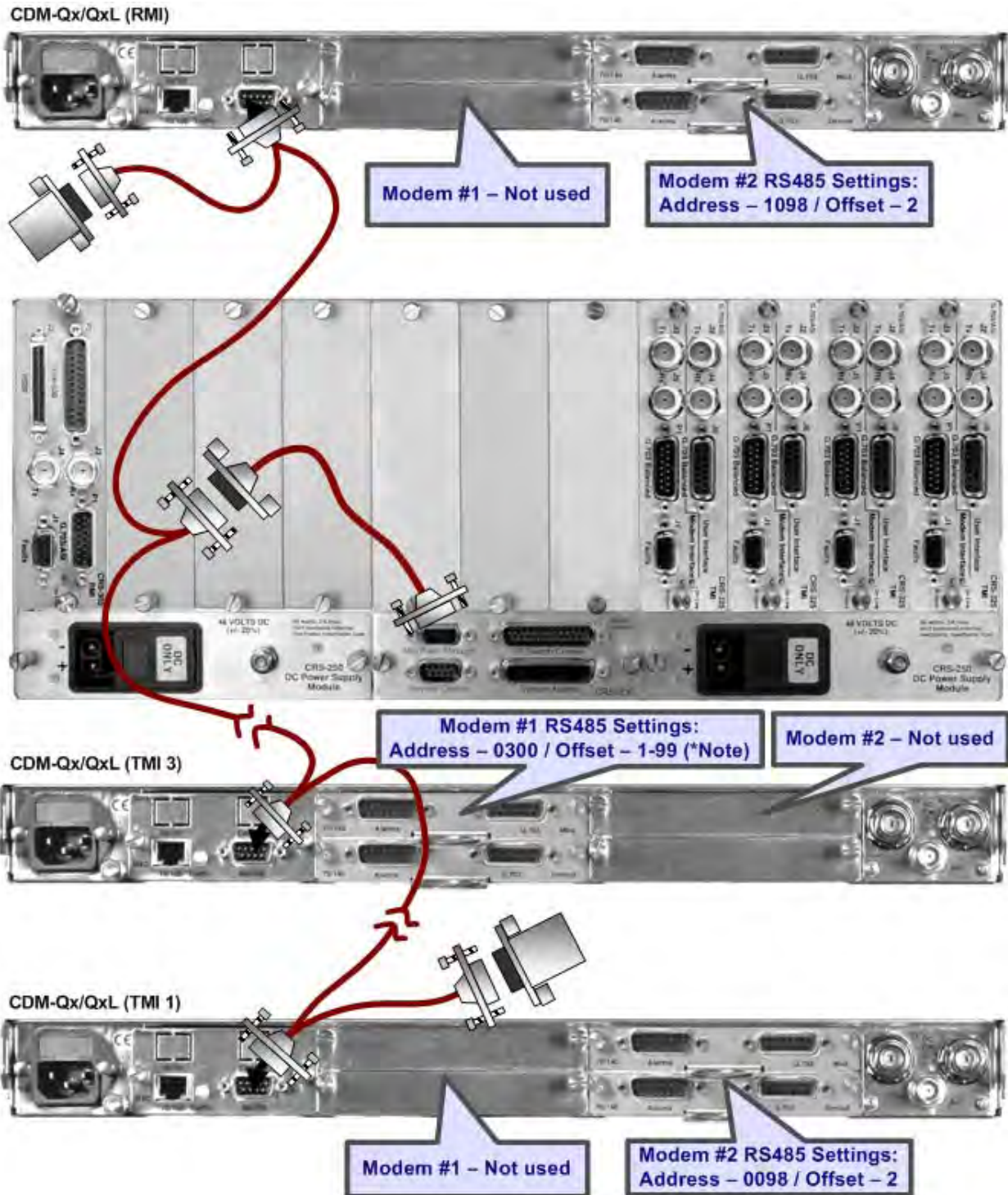


Figure 5-2. CDM-Qx/QxL / CRS-300 EIA-485 Scheme

## 5.2.4.5 Configure Switch-to-CDM-710G/710GL, CDM-710, CDM-700 1:N Redundancy



Only the **Rev. A** modem chassis (i.e., the chassis with a round-buttoned front panel keypad) and later versions of the CDM-710 and CDM-700 offer 1:N Redundancy operation.

The Switch communicates to the Redundant and Traffic modems via a serial TTL bus contained within the CDM-710G/710GL, CDM-710, or CDM-700 DB-15 “P1 | Alarms” connector on the modem rear panel. A DB-15 to HD-15 Control Cable connects each modem to the Switch.

Use the modem front panel menu to configure the modem and Switch for 1:N Redundancy (make sure to press **ENT** to save your changes). Do these steps:

Step	Task
1	<p><i>If the terrestrial data type is Ethernet:</i> For each modem that is on the same subnet, enter a unique IP Address for the CDI-70 (GigE Interface):</p> <ul style="list-style-type: none"> <li>For the CDM-710G/710GL or CDM-710: <b>CONFIG → Intfc2 → MAN → ADDRESS</b></li> <li>For the CDM-700: <b>CONFIG → Intfc1 → MAN → ADDRESS</b></li> </ul>
2	<p>Configure the DB-15 “P1   Alarms” connector on the modem rear panel for “Redundancy Mode”. Set redundancy on each modem to the <b>Active</b> state:</p> <p style="text-align: center;"><b>CONFIG → AUX (Redundancy Mode) → ENA/DIS → set to Enable.</b></p> <p>Press <b>ENT</b> to save your changes. You are not required to configure any further COMM menus for the modems.</p>
3	<b>Power down</b> all modems.
4	<b>Power up</b> all modems. Verify that each Traffic Modem is <b>ONLINE</b> via the front panel LEDs.



All configuration changes can only be made to the Online CDM-710G/710GL, CDM-710, or CDM-700 and will require you to “Save Parameters to permanent storage” to make sure the configuration change is also applied to the Redundant Modem.



See the *CDM-710G/710GL, CDM-710, or CDM-700 Installation and Operation Manuals* for detailed configuration information.

### 5.3 RMI Card Configuration Reference



Comtech EF Data provides this RMI Card Configuration Reference for RMI identification purposes only. Comtech EF Data ships all RMI cards pre-configured – they require no user adjustments.

Comtech EF Data ships the CRS-305, CRS-306, and CRS-307 RMI cards pre-set for proper operation. Each card shares a common printed circuit board (CEFD P/N PC/11494x); what distinguishes the cards from one another is the configuration of front panel connectors, and configuration of the Jumper “JMP1” setting on the PCB.

Figure 5-3 identifies the “JMP1” jumper location that typical for all RMI PCBs.

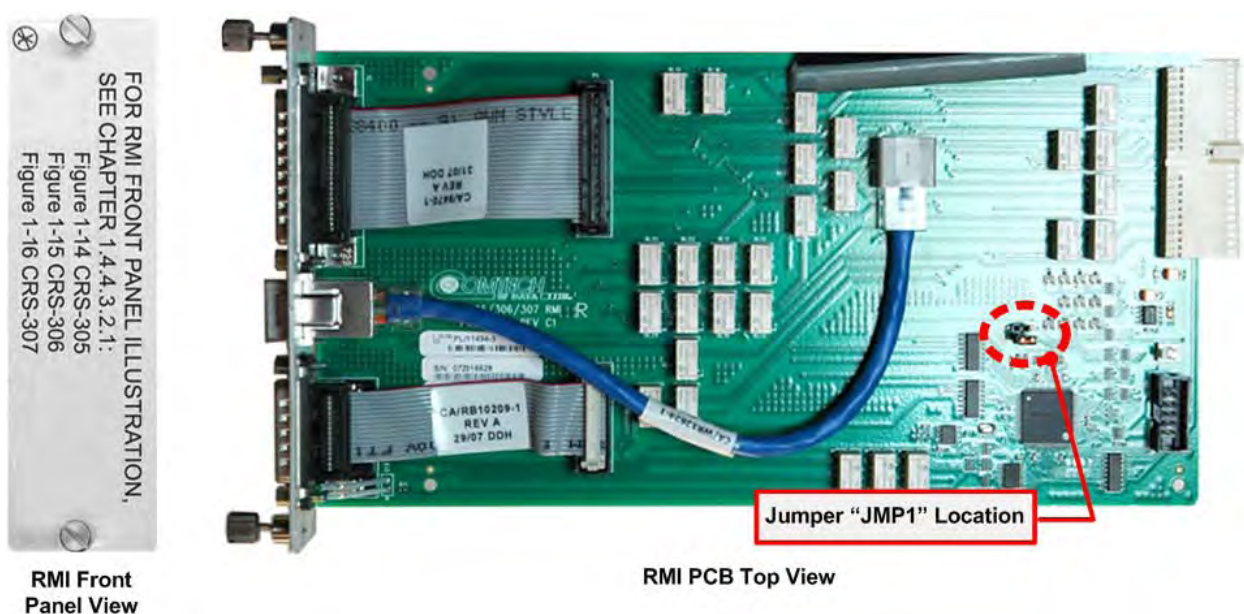
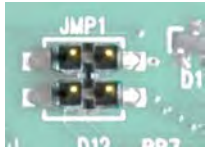

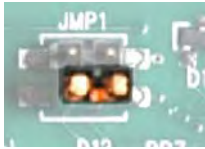


Figure 5-3. CEFD P/N PC/11494x RMI PCB (CRS-307 shown)

Table 5-1 defines the Jumper “JMP1” settings, as shipped from the factory, for each RMI card.

Table 5-1. RMI “JMP1” Jumper Settings (As Shipped)

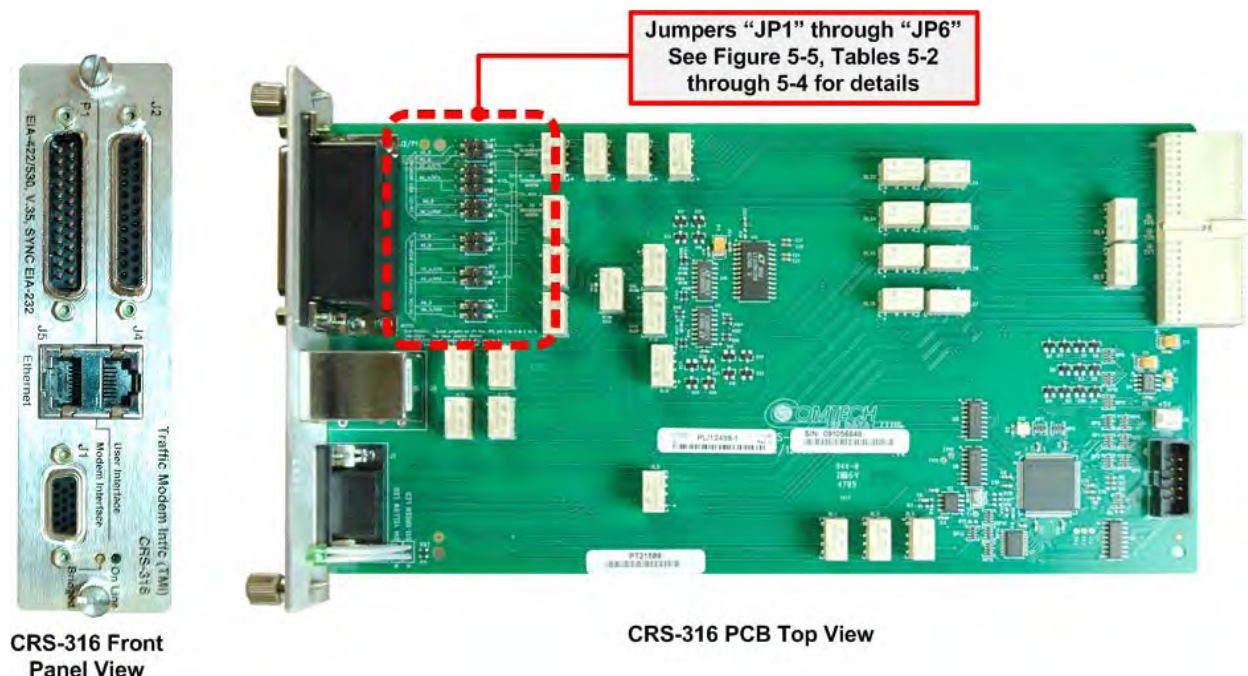
“JMP1” Jumper Setting – AS SHIPPED		
CRS-305 No jumpers	CRS-306 Pins ‘1’ to ‘2’ Jumped	CRS-307 Pins ‘3’ to ‘4’ Jumped
		

## 5.4 TMI Card Configuration Reference

This subsection shows the modem-specific configuration settings for each TMI card. Comtech EF Data ships these TMIs with their jumpers pre-set for proper operation.

### 5.4.1 EIA-530 Interfaces via the CRS-316 TMI

Figure 5-4 shows the CRS-316 TMI (CEFD P/N PL/12498, Rev 'A' or later).



**Figure 5-4. CRS-316 EIA-530 TMI Card (Jumpers Shown Open)**

Figure 5-5 shows the jumper section of the CRS-316 TMI PCB. Comtech EF Data ships these TMIs pre-set with jumpers “JP1” through “JP6” **open**.

Table 5-2, Table 5-3, and Table 5-4 define the jumper settings for the modem-specific control signal configurations:

- **For CDM-625/A modems** – the permitted settings for jumpers “JP1” and “JP2” **only** are:
  - For ‘RTS to CTS’ Loop – Pin ‘1’ to Pin ‘3’ (“JP1” to “JP2”) jumped
  - For ‘RTS to Control TX IF Mute’ operation for online modem – Pin ‘3’ to Pin ‘5’ (“JP2”) jumped
- **For SLM-5650A modems** – the settings for jumpers “JP1” thru “JP6” are:
  - Pin ‘1’ to Pin ‘2’ jumped
  - Pin ‘3’ to Pin ‘4’ jumped



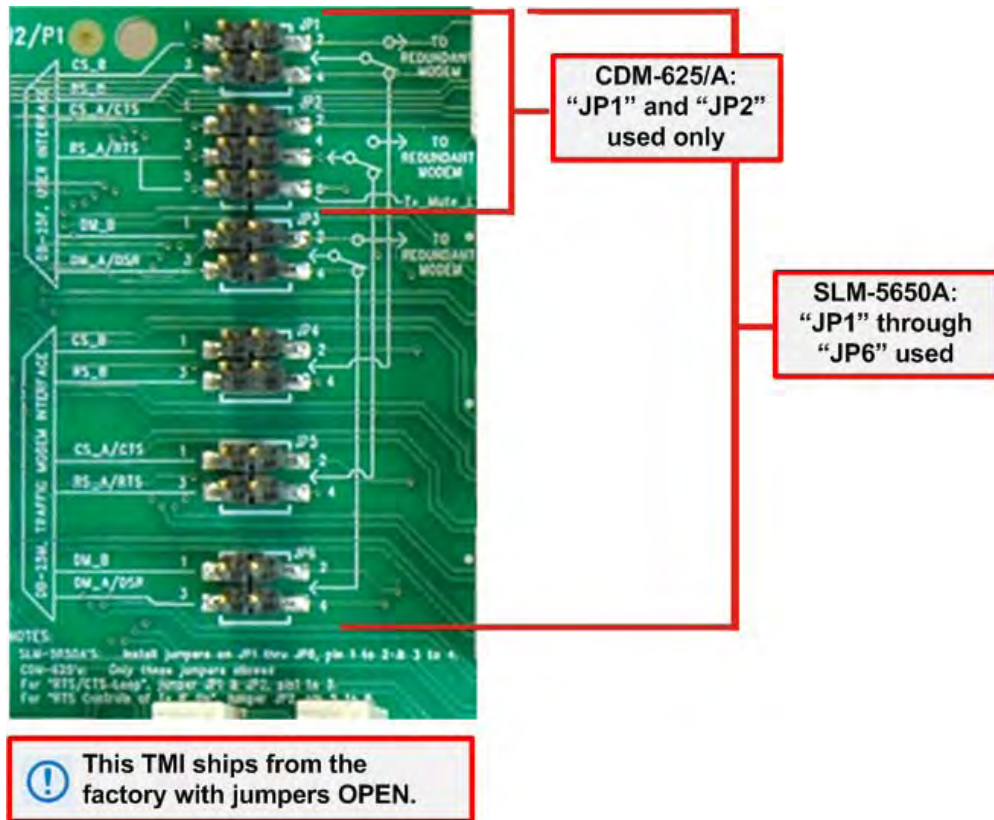
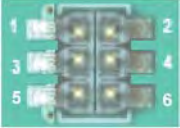





Figure 5-5. CRS-316 “JP1” through “JP6” Jumper Detail (As Shipped)

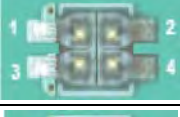

Table 5-2. CRS-316 “JP1” Jumper Settings

User Interface Jumper “JP1”			
Modem	Control Signal Settings	Jumper Settings	
		Detail	Pins Jumped
CDM-625/A	CS_B & RS_B Signals <i>Not Connected</i>		N/A <i>(Note: TMI as shipped)</i>
CDM-625/A	CS_B to RS_B <i>Loop Connected at User DB-25 Connector</i>		'1' to '3'
SLM-5650A	CS_B & RS_B <i>Routed to online modem</i>		'1' to '2' '3' to '4'

**Table 5-3. CRS-316 “JP2” Jumper Settings**

User Interface Jumper “JP2”			
Modem	Control Signal Settings	Jumper Settings	
		Detail	Pins Jumped
CDM-625/A	CS_A/CTS & RS_A/RTS <i>Not Connected</i>		N/A <i>(Note: TMI as shipped)</i>
CDM-625/A	CS_A/CTS & RS_A/RTS <i>Loop Connected at User DB-25 Connector</i>		'1' to '3'
CDM-625/A	RTS <i>Controls Online Modem's Tx IF mute operation</i>		'3' to '5'
SLM-5650A	CS_A/CTS & RS_A/RTS <i>Routed to Online Modem</i>		'1' to '2' '3' to '4'

**Table 5-4. CRS-316 “JP3” through “JP6” Jumper Settings**

User Interface Jumpers “JP3” through “JP6”			
Modem	Control Signal Settings	Jumper Settings	
		Detail	Pins Jumped
CDM-625/A	DM/DSR, CS, RS, CS/CTS, RS/RTS, DM/DSR <i>Not Connected</i>		N/A <i>(Note: TMI as shipped)</i>
SLM-5650A	DM/DSR, CS, RS, CS/CTS, RS/RTS, DM/DSR <i>Routed to Traffic Modem</i>		'1' to '2' '3' to '4'

### 5.4.2 EIA-232/-422, V.35 Interfaces via the CRS-320 and CRS-340 TMIs

Jumpers “JP1” and “JP2” on the CRS-320 (obsolete) and CRS-340 TMI cards set the functionality of the control signals *DTR/DSR* and *RTS/CTS*. See **Figure 5-6** and **Figure 5-7** – Comtech EF Data ships these TMIs pre-set with jumpers “JP1” and “JP2” open.

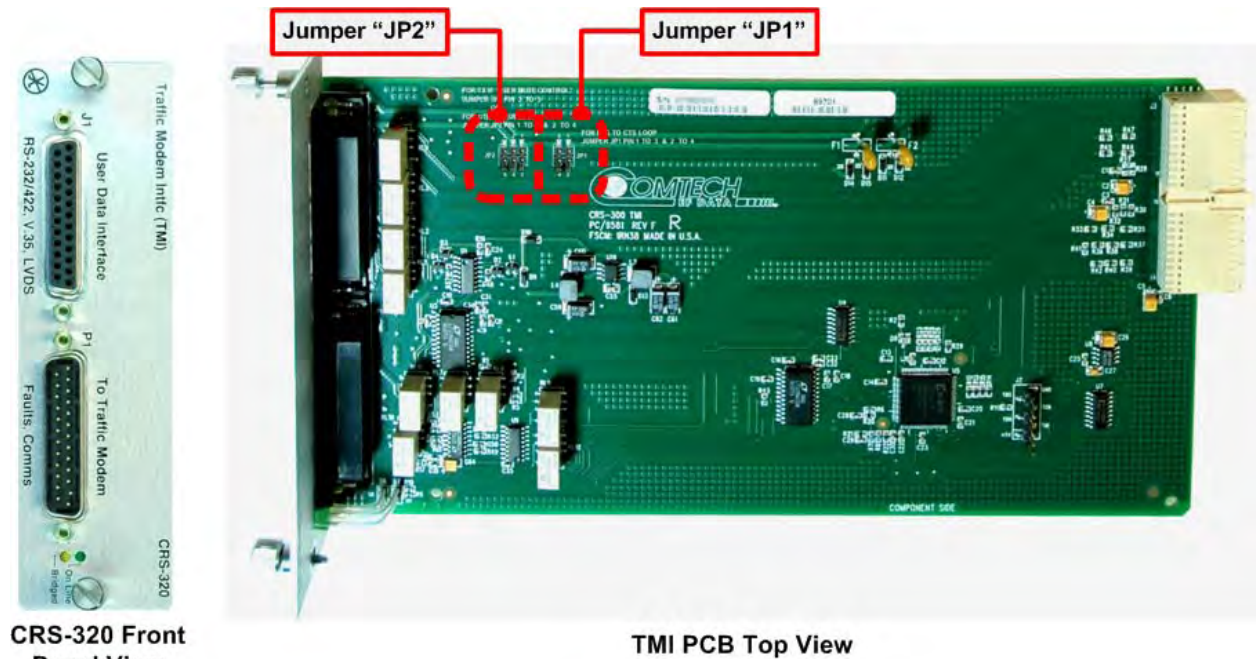


Figure 5-6. CRS-320 EIA-232/EIA-422 TMI Card (Jumpers Shown Open)

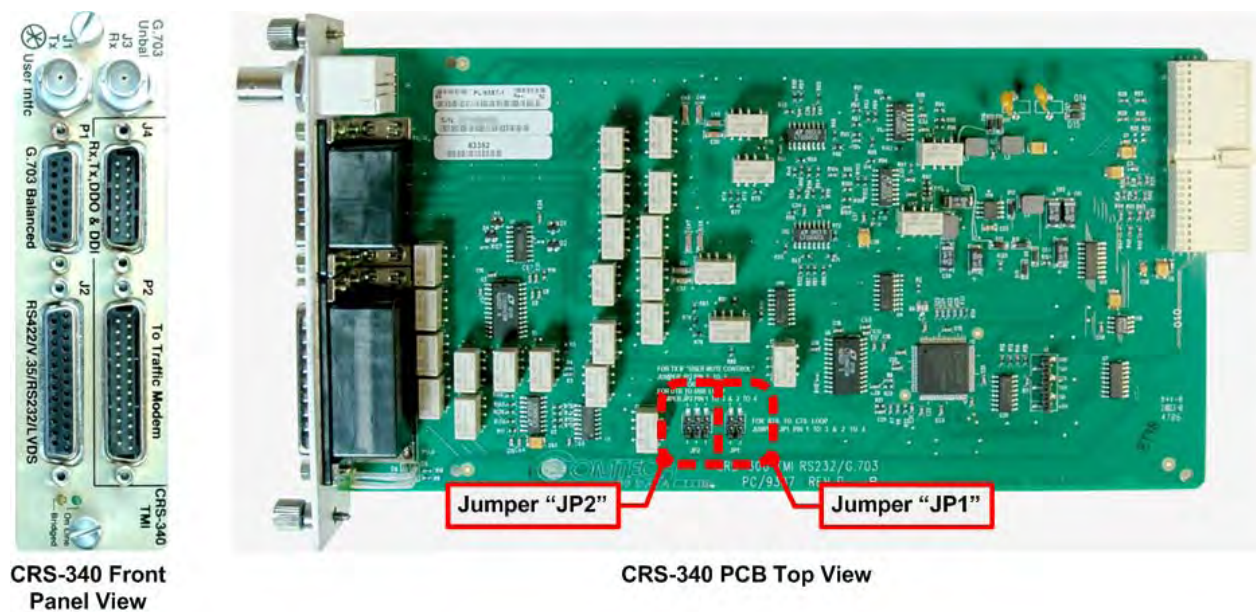







Figure 5-7. CRS-340 EIA-232/-422/G.703 TMI Card (Jumpers Shown Open)

**Table 5-5** defines the CRS-320 (obsolete) and CRS-340 TMI control signal configuration jumper “JP1” and “JP2” settings:

**Table 5-5. CRS-320/CRS-340 Jumper Settings**

Jumper “JP1”			Jumper “JP2”		
Control Signal Setting	Jumpers	Settings (Pins Jumped)	Control Signal Setting	Jumpers	Settings (Pins Jumped)
RTS/CTS Open Circuit (TMI as-shipped)		None	DTR/DSR Open Circuit (TMI as-shipped)		None
RTS to CTS Loop		‘1’ to ‘3’ ‘2’ to ‘4’	DTR to DSR Loop		‘1’ to ‘3’ ‘2’ to ‘4’
			TX IF “User Mute Control” Connects User DB-25 Pin ‘23’ to Online Modem’s “Tx_IF_Mute_L”: • 0 = Mute (Tx_IF Off) • 1 = No Mute (Tx_IF On)		‘3’ to ‘5’



These jumper settings are possible *only* on the following TMI versions:

- For the CRS-320 (obsolete) – Rev. F. and later versions
- For the CRS-340 – Rev. D and later versions

### 5.4.3 HSSI Interfaces via the CRS-336 TMI

Figure 5-8 and Figure 5-9 show the CRS-336 TMI (CEFD P/N PL/12499, Rev B or later). Comtech EF Data ships these TMIs with jumpers “JP1” and “JP2” pre-set on a per-modem basis:

- **For CDM-625/A modems** – the jumper settings for the ‘CA to TA’ Loop are:
  - Pin ‘1’ to Pin ‘3’ (“JP1” and “JP2”) jumped
- **For SLM-5650A modems** – the jumper settings are:
  - Pin ‘1’ to Pin ‘2’ jumped
  - Pin ‘3’ to Pin ‘4’ (“JP1” and “JP2”) jumped

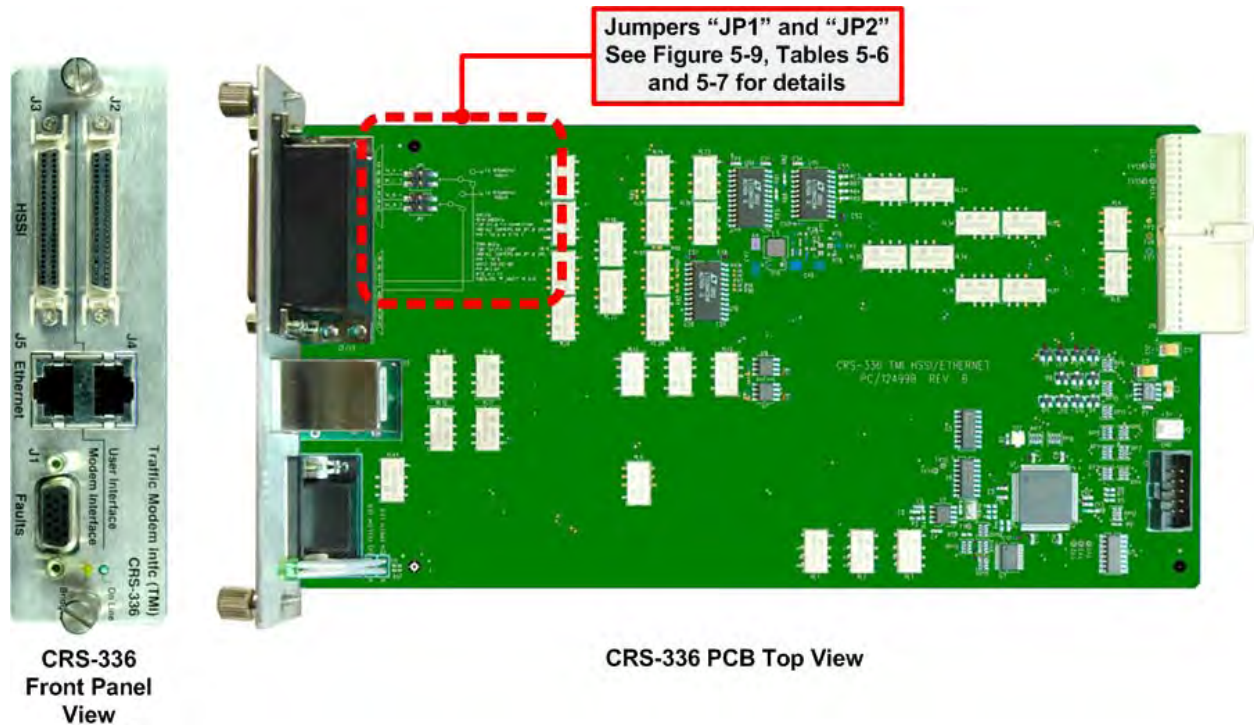


Figure 5-8. CRS-336 HSSI or Ethernet TMI Card

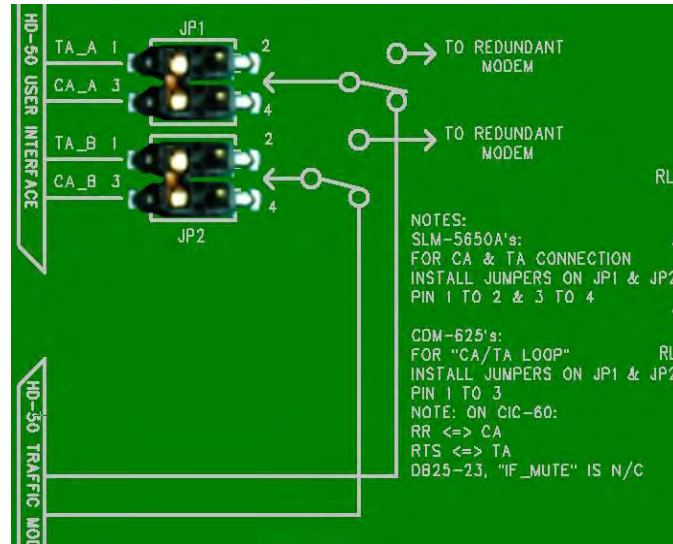


Figure 5-9. CRS-336 “JP1” and “JP2” Jumper Detail (As Shipped)

Table 5-6. CRS-336 Jumper “JP1” Settings

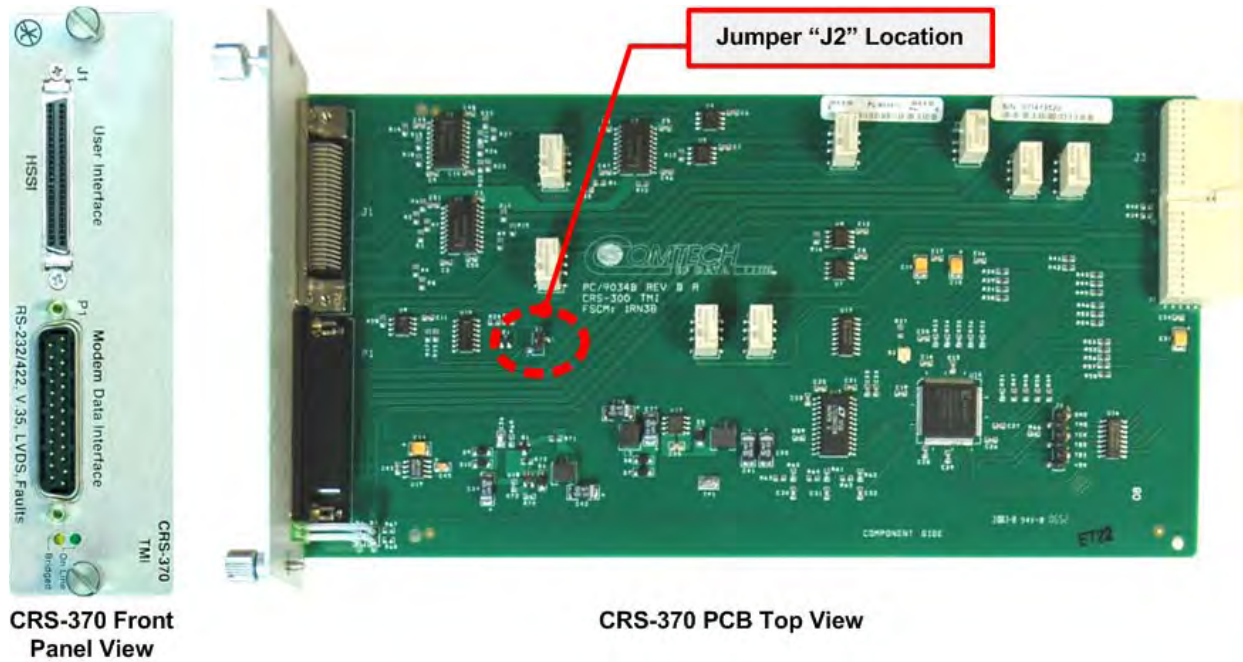
User Interface Jumper “JP1”			
Modem	Control Signal Setting	Jumper Settings	
		Detail	Settings (Pins Jumped)
CDM-625/A	TA_A to CA_A Loop Connected at User HSSI Connector		'1' to '3' (Note: TMI as shipped)
SLM-5650A	TA_A & CA_A Routed to online modem		'1' to '2' '3' to '4'

Table 5-7. CRS-336 Jumper “JP2” Settings

User Interface Jumper “JP2”			
Modem	Control Signal Setting	Jumper Settings	
		Detail	Settings (Pins Jumped)
CDM-625/A	TA_B to CA_B Loop Connected at User HSSI Connector		'1' to '3' (Note: TMI as shipped)
SLM-5650A	TA_B & CA_B Routed to online modem		'1' to '2' '3' to '4'

### 5.4.4 HSSI Interface via the CRS-370 TMI

Jumper “J2” on the CRS-370 TMI selects the functionality of the control signals **CA** and **TA**. See **Figure 5-10** – Comtech EF Data ships this TMI pre-set with jumper “J2” **open**.



CRS-370 Front  
 Panel View

CRS-370 PCB Top View

**Figure 5-10. CRS-370 HSSI to LVDS TMI Card (Jumper Shown Open)**

**Table 5-8** defines the CRS-370 TMI control signal configuration Jumper “J2” settings.

**Table 5-8. CRS-370 Jumper “J2” Settings**


User Interface Jumper “J2”		
Control Signal Setting	Detail	Jumper Setting
<b>TA to CA Loop</b> <i>(Note: TMI as-shipped)</i>		None
<ul style="list-style-type: none"> <li>• TA controls TX carrier</li> <li>• RR controls CA</li> </ul>		Installed

---

## 5.5 Configure the CRS-300 Switch

### 5.5.1 Connect the Switch Power

Do these steps to connect the power cords:

Step	Task
1	Make sure that both power supply switches are in the <b>OFF</b> position before you connect the power supply power cords.
2	Comtech EF Data supplies each Switch with two power cords. Connect the female end of these power cords (one to each power supply power input) to the power supply connectors.
3	Plug both power cords into the power source(s).
	 <b>The auto-sensing power supplies require no adjustments.</b>
4	Once all system connections are in place, turn both power supplies <b>ON</b> .



**CAUTION – the IEC line input connector for each power supply card contains the ON/OFF switch for that card. Each Switch is shipped with two power supplies. It is recommended that both be used for maximum reliability.**

If you use only one power supply card, you must use the CRS-300 Front Panel menu to mask the fault for the unused power supply. Do these steps:

Step	Task
1	Use the ◀ ▶ arrow keys to select the nested <b>CONFIG → OPTIONS → MASKS → SW-ALARMS</b> menu.
2	Select the unused power supply to mask its faults.

### 5.5.2 About the Switch Fuses



**WARNING! For continued operator safety, always replace the fuses with the correct type and rating. For 115/230 volt AC operation, use T1A (slow-blow) 20 mm fuses.**

The power supplies contain two fuses, one each for line and neutral connections (or L1, L2 where appropriate). These are contained within the body of the connector, behind the small plastic flap.



## 5.6 Update the CRS-300 Switch Firmware



**Make sure to operate the CRS-300 and all installed modems with the latest available firmware.**

The CRS-300 1:10 Redundancy Switch is factory-shipped with its latest version of operating firmware. If you need to update the Switch firmware, you may download the update from the Comtech EF Data Web site ([www.comtechefdata.com](http://www.comtechefdata.com)). You may also receive the firmware update archive file via e-mail from Comtech EF Data Product Support.

You may perform the firmware update, without opening the CRS-300, by directly connecting a user-supplied Microsoft Windows-based PC to the “Remote Control” connector located on the CRS-230 System Controller Card.

### Do these steps:

- Download the firmware update archive file via the Internet to the User PC.
- Once the firmware update is extracted from the transferred archive file, execute the update process via use of the supplied **CCCFIash.EXE** Utility Application.

### 5.6.1.1 About Firmware Files, Naming, Versions, and Archive Formats

Comtech EF Data’s Web site catalogues its firmware update files by product type (e.g., modem, converter, switch, etc.) and specific model/optional configurations. Comtech EF Data provides modem-specific firmware updates for the CRS-300 as follows:

Web Hyperlink	EXE/ZIP Filename	Use for Modem
F0000092*_V###	FW-0000092*	CDM-625/A
F0000132*_V###	FW0000132*	CDM-570/L, CDM-570A/AL
F0000090*_V###	FW0000090*	SLM-5650/5650A
F0000094*_V###	FW0000094*	CDM-Qx/QxL
F12807*_V###	FW12807*	CDM-710G/710GL, CDM-710
F12520*_V###	FW12520*	CDM-700
F0000134*_V###	FW0000134*	CDM-600/L
F1435*_V###	F1435*	All other products

The hyperlink naming, **F#####\*\_V###** is defined in this table as follows:

- ‘**F#...#**’ indicates the four-to-six digit Firmware Number.
- ‘**\***’ Indicates the Maintenance Release Letter (e.g., Rev ‘A’ of FW Ver. 1.1.1)
- ‘**V###**’ indicates the Firmware Version Number (e.g., Ver. 1.1.1)

The firmware download files are available from Comtech EF Data in two archive file formats: \*.exe (self extracting) and \*.zip (compressed). Some firewalls will not allow the downloading of \*.exe files; in this case, download the \*.zip file instead. If applicable, one version prior to the current release is also available for download.




**For additional help with "zipped" file types, refer to the help files provided with the "PKZIP for Windows", "WinZip", or "ZipCentral" file archiving programs. "PKZIP for Command-line" is not supported due to file naming conventions.**

To verify the correct firmware number, see Step 2 in **Sect. 5.5.3.2.1 Getting Started: Prepare for the Firmware Download**.

## 5.6.1.2 Switch Firmware Update Procedure

### 5.6.1.2.1 Getting Started: Prepare for the Firmware Download

Step	Task
1	Connect the Switch "Remote Control" connector (located on the CRS-230 System Controller) to a serial port on your Windows-based User PC. Make sure that you are running a terminal emulator program on your PC such as Tera Term or PuTTY.
2	<p>Identify the CRS-300 firmware number and current running version:</p> <ul style="list-style-type: none"> <li>• <i>From the Switch front panel</i> – the firmware version is available from the VFD's top-level "splash" screen. To view this screen, press the [CLR] key several times.  For more information, see <b>Chapter 6. FRONT PANEL OPERATION</b>.</li> <li>• <i>Using Serial Remote Control query</i> – the firmware version can be obtained with the &lt;0SWR? query.  For more information, see <b>Chapter 7. SERIAL-BASED REMOTE PRODUCT MANAGEMENT..</b></li> </ul>
3	<p>Create a temporary folder (subdirectory) on the User PC for the firmware archive file download.</p>  <ul style="list-style-type: none"> <li>• <b>These examples use drive letter "c:". You may use any valid, writable drive letter.</b></li> <li>• <b>Typical for all tasks: Type the command <u>without quotes</u>, and then press [ENT] to execute.</b></li> </ul> <p>You may create a temporary folder on a Windows-based PC using differing methods:</p> <p><b>A.</b> Use the <i>Windows Desktop</i> to create and rename the temporary folder.</p> <ul style="list-style-type: none"> <li>• Right-click anywhere on the desktop to open the popup submenu, and then select <b>New &gt; Folder</b> to create the temporary folder. The "New Folder" will be created on the desktop.</li> <li>• Right-click on the "New Folder" and then select 'Rename' from the popup submenu. Rename this folder to "<i>temp</i>" or some other convenient, unused name.</li> </ul> <p><b>B.</b> Use <i>Windows Command-line</i> to create the temporary folder.</p> <ul style="list-style-type: none"> <li>• First, click [Start] on the Windows taskbar, and then click the <b>Run...</b> icon (or, depending on Windows OS versions <i>prior</i> to Windows 95, click the <i>MS-Command-line Prompt</i> icon from the Main Menu).</li> </ul>

Step	Task
3 (cont.)	<ul style="list-style-type: none"> <li>• Next, open a Command-line window...               <ul style="list-style-type: none"> <li>○ For Windows 95 or Windows 98, type “<b>command</b>”.</li> <li>○ For any Windows OS versions later than Windows 98, type “<b>cmd</b>” or “<b>command</b>”.</li> <li>○ Alternately, from [<b>Start</b>], select <b>All Programs &gt; Accessories &gt; Command Prompt</b>.</li> </ul> </li> <li>• Finally, from the Command-line prompt (c:\&gt;), type “<b>mkdir temp</b>” or “<b>md temp</b>” (<i>mkdir</i> and <i>md</i> stand for <i>make directory</i>), and then click [<b>OK</b>].</li> </ul> <p><b>C.</b> Use the ‘<i>Run</i>’ and ‘<i>Browse</i>’ windows to create and rename the temporary folder.</p> <ul style="list-style-type: none"> <li>• Select [<b>Start</b>] on the Windows taskbar, and then click the <b>Run...</b> icon. The ‘<b>Run</b>’ window will open.</li> <li>• Click [<b>Browse</b>] in the ‘<b>Run</b>’ window. The ‘<b>Browse</b>’ window will open.</li> <li>• Click the <b>Create New Folder</b> icon in the ‘<b>Browse</b>’ window. The “<i>New Folder</i>” will be created.</li> </ul> <p>Right-click the “<i>New Folder</i>” folder name, and then rename this folder to “<i>temp</i>” or some other convenient, unused name.</p>

***There should now be a "temp" folder created and available for placement of the firmware archive file download.***


### 5.6.1.2.2 Download and Extract the Firmware Update

Step	Task
1	<p>Download the correct firmware archive file to the User PC temporary folder.</p> <ul style="list-style-type: none"> <li><b>A.</b> Go online to <a href="http://www.comtechefdata.com">www.comtechefdata.com</a>.</li> <li><b>B.</b> On the <i>Main</i> page – under <b>Support Information</b>, select the <b>Software Downloads</b> hyperlink. You may also click the <b>Support</b> tab, and then click the <b>Software Downloads</b> icon from the <b>Support</b> page.</li> <li><b>C.</b> On the <i>Software Downloads</i> page – click <i>Download Flash and Software Update Files</i>.</li> <li><b>D.</b> On the <i>Flash &amp; Software Update Files</i> page – select the <i>Modem Accessories</i> hyperlink.</li> <li><b>E.</b> On the <i>Modems</i> product page – select the <i>CRS-300</i> product hyperlink.</li> <li><b>F.</b> Select the appropriate modem-specific firmware EXE or ZIP download hyperlink</li> </ul> <p>Refer to the table in <b>Sect. 5.5.2.1 About Firmware Numbers, File Versions, and Formats</b> in this chapter for the naming and availability of the firmware download hyperlinks, archive files, and downloaded image files.</p> <ul style="list-style-type: none"> <li><b>G.</b> Download the archive file to the temporary folder.</li> </ul> <p>Once the EXE or ZIP hyperlink is selected, the ‘<b>File Download</b>’ window opens and prompts selection of [<b>Open</b>] or [<b>Save</b>]:</p>

Step	Task										
<b>1</b> <b>(cont.)</b>	<ul style="list-style-type: none"> <li>Click <b>[Open]</b> to turn over file extraction to the user-supplied Utility Application. Make sure to extract the firmware files to the “temp” folder created earlier.</li> <li>Click <b>[Save]</b> to open the ‘Save As’ window. Make sure to select and <b>[Save]</b> the *.exe or *.zip archive file to the “temp” folder created earlier.</li> </ul> <p>Otherwise, click <b>[Cancel]</b> to quit and exit the file download process.</p>										
<b>2</b>	<p>Extract the firmware files from the downloaded *.exe or *.zip archive file with the user-supplied Utility Application (if not already done with <b>File Download &gt; [Open]</b>).</p> <p>Using the CDM-625/A firmware download archive for the Switch as an example, at least four files should be extracted:</p> <table border="1" data-bbox="462 632 1260 827"> <thead> <tr> <th>Name</th> <th>Type</th> </tr> </thead> <tbody> <tr> <td>CCCflash.hlp</td> <td>Help file</td> </tr> <tr> <td>CCCFLSHC.EXE</td> <td>Application</td> </tr> <tr> <td>FW-0000092H_CRS-300_CDM625_02_24.CCC</td> <td>CCC File</td> </tr> <tr> <td>FW-0000092H_ReleaseNotes_v224.pdf</td> <td>Adobe Acrobat Document</td> </tr> </tbody> </table> <ul style="list-style-type: none"> <li><b>CCCflash.hlp</b>: The CEFD Flash Upload Utility Application Help File.</li> <li><b>CCCFlash.exe</b> or <b>CCCFLSHC.EXE</b>: The CEFD Flash Upload Utility Application, compatible for use under Windows 95/98/2000® or Windows NT®.</li> <li><b>FW-0000092*.ccc</b>: The firmware image file.</li> <li><b>FW-0000092* _ReleaseNotes_V###.pdf</b>: The firmware release notes</li> </ul>	Name	Type	CCCflash.hlp	Help file	CCCFLSHC.EXE	Application	FW-0000092H_CRS-300_CDM625_02_24.CCC	CCC File	FW-0000092H_ReleaseNotes_v224.pdf	Adobe Acrobat Document
Name	Type										
CCCflash.hlp	Help file										
CCCFLSHC.EXE	Application										
FW-0000092H_CRS-300_CDM625_02_24.CCC	CCC File										
FW-0000092H_ReleaseNotes_v224.pdf	Adobe Acrobat Document										
<b>3</b>	<p>Confirm availability of the firmware files in the temporary folder. There are a number of ways you may view the contents of the temporary folder on a Windows-based PC:</p> <p><b>A.</b> From the Windows Desktop:</p> <ul style="list-style-type: none"> <li>Double-left-click the “temp” folder saved to the Windows Desktop.</li> <li>Use Windows Explorer to locate, and then double-left-click the “temp” folder.</li> <li>Use the ‘Browse’ window (<b>[Start] &gt; ...Run &gt; [Browse]</b>) to locate, and then double-click the “c:\temp” folder.</li> </ul> <p><b>B.</b> Using Command-line:</p> <ul style="list-style-type: none"> <li>Type “<b>cd c:\temp</b>” at the prompt to change to the temporary directory created earlier using Command-line.</li> <li>Type “<b>dir</b>” to list the files extracted to the temporary directory from the downloaded archive file.</li> </ul>										

***The firmware files have been successfully downloaded to the User PC and are now available for FTP upload to the Switch via the CCCFLASH Utility Application.***

### 5.6.1.2.3 Execute the CCCFLASH Upload Utility Application

Step	Task
1	<p>Make sure a User PC serial port is connected to the CRS-300 "Remote Control" connector (located on the CRS-230 System Controller Card) with a user-provided EIA-232 serial cable.</p> <p>(Cabling details are shown in the CCCFLASH Uploader dialogue box, and provided in <b>Appendix B. CABLE DRAWINGS.</b>)</p>  <p><b>Full on-line help is provided with the CCCFlash Upload Utility Application. Contact Comtech EF Data Product Support if you have additional questions or need assistance.</b></p>
2	<p><b>Run the CCCFLASH Upload Utility Application:</b></p> <ul style="list-style-type: none"> <li>• Double click on the <b>CCCFLSHC.EXE</b> filename or desktop icon to open the application.</li> <li>• Follow the prompts presented in the application dialog boxes (e.g., select the serial port, upload baudrate, firmware image file, etc.) and then execute the upload process.</li> </ul>
3	<p>Following the successful upload process, the Switch will automatically restart, running the new version of firmware. During this process, the non-volatile RAM storing the configuration of the Switch will be erased, so you are then required to re-enter the desired configuration.</p>

***Firmware Update Procedure is now complete. The CRS-300 1:10 Redundancy Switch is now operating with its current firmware.***

## 5.6.2 Configure the CRS-300 Switch Operation



### Chapter 6. FRONT PANEL OPERATION

The Switch should show a **GREEN** "Unit Status" LED. If it is **RED**, go to **MONITOR → SW-ALARM** to view the faults. Make sure that the preceding Redundant Modem setup is complete and that it is operating correctly before proceeding.

Use the CRS-300 Front Panel keypad and display to configure the Switch as instructed in the subsections that follow.

### 5.6.2.1 Activate the Traffic Modems

**Comtech EF Data ships the Switch with no Traffic Modems set to "Active"**. You may operate the Switch with only some of the 10 slots filled/occupied. A TMI can be 'active' only when present. If there are unused TMIs in the Switch, make sure you use the **CONFIG: ACTIVE** menu to deactivate them. The Switch will actively poll any activated Traffic Modems.

Use the CRS-300 Front Panel menu to activate the desired Traffic Modems (make sure to press **[ENT]** to save your changes). Do these steps:

Step	Task
1	Use the [ <b>←</b> ][ <b>→</b> ] keys to select the <b>CONFIG: ACTIVE</b> menu.
2	Use the [ <b>↑</b> ] arrow key to activate all desired Traffic Modems.

Once you press **[ENT]**, the **Switch Status** LED turns **RED** until the Switch polls each activated modem and correctly programs the bridged modem configuration into the Redundant Modem.

The Redundant Modem may take several seconds to configure. Once this programming completes successfully, the **RED** LED turns **GREEN**. If the LED remains **RED**, you must investigate the problem – use the CRS-300 Front Panel menu to check the communication status:

**MONITOR: COMM-STATE or MONITOR: SW-ALARMS**

Another option is to view the I/O. Review the nested **MONITOR: I/O** screen. Communication is slowed to aid viewing. This screen shows the actual messages to and from the modems; if there are no responses from a modem, check the addressing scheme carefully and verify that your modem communication setups are correct.



**Do not leave the Switch in this view.**

To deactivate a modem, see **Sect. 6.2.2.5 CONFIG: ACTIVE (Activate Modems)**.

### 5.6.2.2 Verify Each Active Modem Connection

The LEDs are arranged in columns corresponding to each modem, and should accurately reflect the status of each. Use the CRS-300 Front Panel menu to verify the modem connections. Do these steps:

Step	Task
1	Verify that the Status LED for each modem shows a <b>GREEN</b> light, indicating no faults. (The Switch Status LEDs will reflect each modem's Status LED.)
2	Verify that the <b>Online</b> LED is lit for all connected TMIs with the modems attached.
3	Verify that the <b>Online</b> LED is not lit for the Redundant Modem.
4	Verify that the <b>Bridge</b> LED is lit for only one Traffic Modem.

**For modems:** Use the read-only **INFO** and **MONITOR** screens to view the status of the modems, in addition to viewing the LEDs.

**For the Switch:** Use the read-only **MONITOR: COMM-STATE** screen to verify that the modems are responding via remote control.

**For real-time monitoring:** Use the read-only **MONITOR: I/O** screen to verify that the modems are responding via remote control. Communication is slowed to aid viewing.



**Do not leave the Switch in this view.**

### 5.6.2.3 Set the Switch Operation Mode



Comtech EF Data ships the Switch in the **AUTO-OFF (manual)** operating mode. The CRS-300 Front Panel menu identifies this manual mode as **AUTO-OFF**.

When in **AUTO-OFF** (manual) mode:

- Although the system is operational, this operational setting causes the Stored Event LED to blink.
- You may manually select which Traffic Modem to bridge or back up.
- The Switch does not *automatically* react to any Traffic Modem failures it detects.

Comtech EF Data recommends that you configure an unattended system to operate in **AUTO** mode. When you enable **AUTO** mode, the first active modem that fails is first bridged by the Redundant Modem, and then backed up.

Use the CRS-300 Front Panel menu to enable **AUTO** mode (make sure to press **[ENT]** to save your changes). Do these steps:

Step	Task
1	Use the [ <b>←</b> ][ <b>→</b> ] keys to select the <b>CONFIG: AUTO</b> menu.
2	Select <b>AUTO</b> mode
3	Verify that the Stored Event LED stops blinking.

### 5.6.2.4 Set the Holdoff Period

A *holdoff period* prevents unwarranted backups due to an intermittent fault. In **AUTO mode**, you may introduce additional delays into the backup procedure. Do this by setting the number of seconds for "holdoff" – i.e, the time specified before a faulted Traffic Modem cedes operation to the Redundant Modem (*backup*), or operation is returned from the Redundant Modem back to the Traffic Modem (*restore*).

The process is further explained:

If a fault occurs in a Traffic Modem and the Redundant Modem operation is fault-free, *backup* is initiated once the configured **Backup Holdoff Period** lapses. However, if the fault clears within the holdoff's configured timeframe, no transfer of operation occurs.

Similarly, if a fault occurs in the Redundant Modem and the Traffic Modem's operation is fault-free, *restore* is initiated once the configured **Restore Holdoff Period** lapses.

The default holdoff period is 10 seconds (a minimum of 1 second and a maximum of 99 seconds is allowed).

### 5.6.2.5 Set the Backup Holdoff Period

If a Traffic Modem fails, the Switch waits for the backup holdoff time to determine two things:

- 1) Does the Traffic Modem remain faulted?

*and*

- 2) Is the Redundant Modem not exhibiting the same fault?

If the answer is **yes** to both questions for the entire backup holdoff time, then the Switch first bridges the faulted modem with the Redundant Modem. If the fault is sustained, then the switchover to the Redundant Modem is completed and the Redundant Modem carries the traffic.

There will be no switchover if the Redundant Modem is faulted. Make sure that the Holdoff times are long enough (default = 10 seconds) for the Redundant Modem to be configured and to lock onto the signal.



**If the CDM-Qx/QxL configuration includes Carrier-in-Carrier<sup>®</sup> this holdoff time should be no less than 8 seconds.**

Use the CRS-300 Front Panel menu to set the **Backup Holdoff Period**. Do these steps:

Step	Task
1	Use the [←][→] keys to select the nested <b>CONFIG: OPTIONS → HOLDOFFS</b> menu.
2	Change the <b>BACKUP HOLDOFF</b> to any number from 1 to 99 seconds.

#### 5.6.2.5.1 Set the Restore Holdoff Period

The "**Restore Holdoff**" setting, which is also programmable from 1 to 99 seconds, determines the Switch's ability to automatically put a backed-up Traffic Modem online again if its fault clears.

Normally, a failed modem that is taken offline remains offline indefinitely. If the fault clears, traffic is returned to the unit (in AUTO mode) only if another Traffic Modem then fails.

If the fault on the originally failed modem has been clear for the full programmed Restore Holdoff time, the Switch places that modem back online and bridges the newly faulted modem. If the new fault is sustained, the Redundant Modem can then be used to back up the newly faulted modem.

If you do not enable the Priority selection (see **Sect. 6.2.2.3.1 CONFIG: OPTIONS → PRIORITY**), then the Switch deals with Traffic Modem failures on a "first come, first serve" basis. If you set the Switch to bridge the highest priority circuit, this will minimize switching time in the event of a failure. If two faults occur simultaneously and are both sustained for the holdoff time, then the Switch will back up the lower-numbered circuit.



Use the CRS-300 Front Panel menu to set the **Restore Holdoff Period**. Do these steps:

Step	Task
1	Use the [←][→] keys to select the nested <b>CONFIG: OPTIONS → HOLDOFFS</b> menu.
2	Change the <b>RESTORE HOLDOFF</b> to any number in the range of 1 to 99 seconds.

### 5.6.2.6 Set the Alarm Masks

Another way to adjust the Switch's reaction in AUTO mode is to mask modem faults. You may disable modem Rx, Tx or both fault types so that the Switch does not react to them. This masking prevents the Switch from taking automatic action and prevents the logging of the faults in the stored events list.

These masks are global to all the modems attached to the Switch.

Use the CRS-300 Front Panel menu to set the **Alarm Masks**. Do these steps:

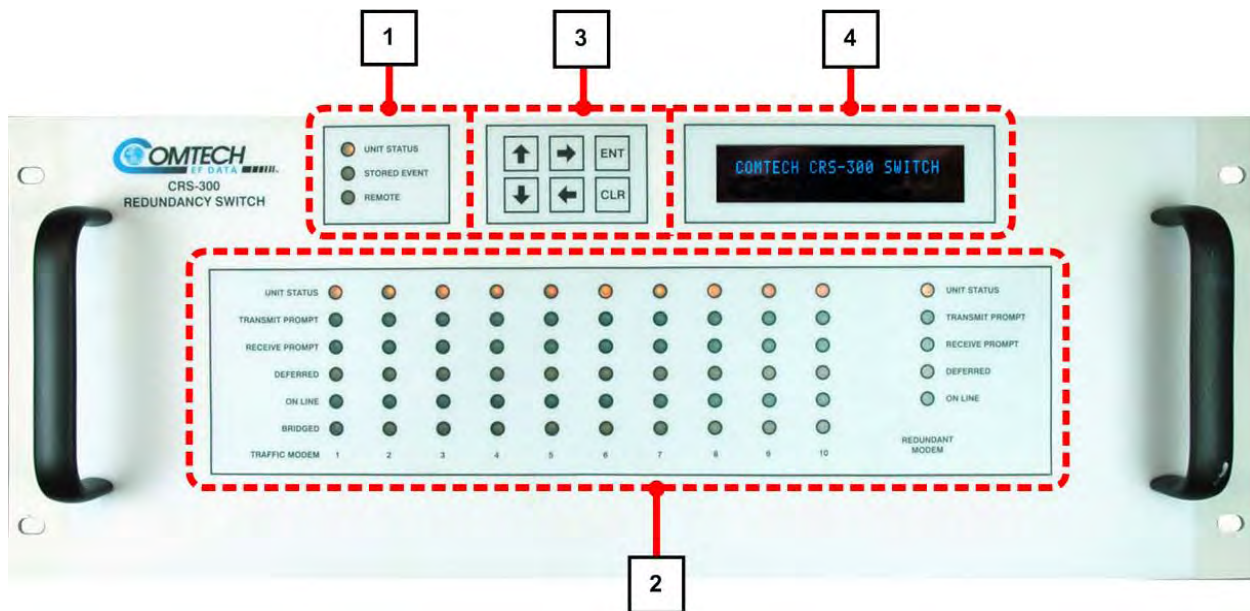
Step	Procedure
1	Use the [←][→] keys to select the nested <b>CONFIG: OPTIONS → MASKS → MODEM-ALARMS</b> menu.
2	Set the mask parameters as desired.

In the event that a second fault occurs, another way to influence Switch behavior is via Priority Mode. For detailed information on Priority Mode, see **Sect. 6.2.2.3.1 CONFIG: OPTIONS → PRIORITY**.



# Chapter 6. FRONT PANEL OPERATION

## 6.1 Overview



Feature	Description	Function	Chapter Sect.
1	<b>Switch Status LED Indicators</b>	These LEDs show the summary status of the Switch.	6.1.1.1
2	<b>Modem Status LED Indicators</b>	These LEDs show the summary status of the Traffic and Redundant modems.	6.1.1.2
3	<b>Keypad</b>	Use the keypad to enter data. The keypad has six individual key switches mounted behind a sealed membrane overlay. The keys have a positive 'click' action that gives tactile feedback.	6.1.2
4	<b>Vacuum Fluorescent Display (VFD)</b>	The VFD shows data, menus, prompts and messages. The VFD is an active display with adjustable brightness. It shows two lines of 24 characters each. Nested menus show all available options and prompts that guide you in carrying out required actions.	6.1.3

**Figure 6-1. CRS-300 Front Panel Features**


## 6.1.1 Front Panel LED Indicators

### 6.1.1.1 Switch Status LED Indicators

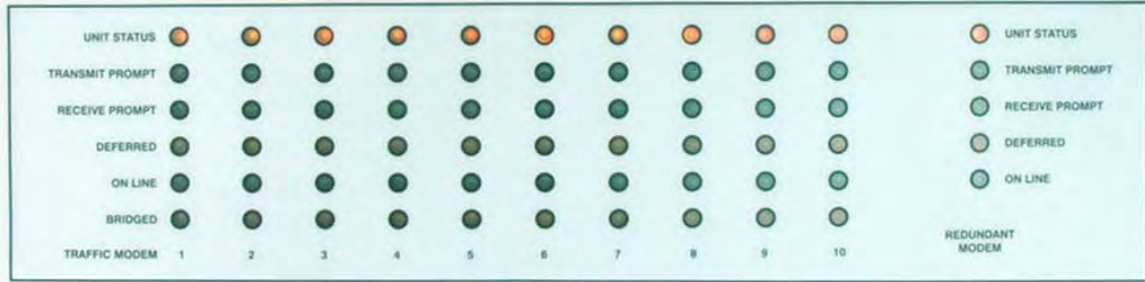


These three front panel LEDs are located adjacent to the keypad. They show the operational status of the CRS-300 1:10 Redundancy Switch.

The LEDs function individually as follows:

LED	Condition	Description
UNIT STATUS	Green	Normal operation (no Switch Faults)
	Red	Switch Fault, e.g., PSU fault or COMMS failure
STORED EVENT	Off	No Stored Events
	Orange	Switch has Stored Events
	Orange (Flashing)	 <b>CAUTION</b> – Switch is in <b>MANUAL</b> mode
REMOTE	Off	Switch is in Local Mode – remote monitoring is possible, but remote configuration control is not allowed
	Orange	Switch is in Remote Mode – configuration changes are disabled via the front panel keypad

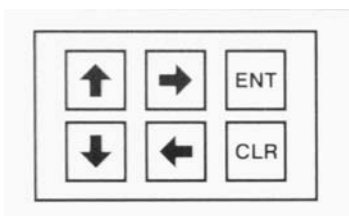
### 6.1.1.2 Modem Status LED Indicators



This array of front panel LEDs, located below the Unit Status LED Indicators group, keypad, and VFD, show the operational status for up to 10 Traffic Modems (six LEDs per modem) plus the Redundant Modem (five LEDs). They function independently as follows:

LED	Condition	Description
UNIT STATUS	Green	Normal operation (no Unit, Tx or Rx Fault)
	Red	<ul style="list-style-type: none"> <li>Unit Fault</li> <li>Rx and Tx fault for SLM-5650/5650A</li> </ul>
	Orange	<ul style="list-style-type: none"> <li>Tx or Rx Fault</li> <li>TMI not installed</li> </ul>
TRANSMIT PROMPT	Green	Normal operation (no Tx Fault)
	Off	Tx Fault
RECEIVE PROMPT	Green	Normal operation (no Rx Fault)
	Off	Rx Fault
DEFERRED (Traffic modems only, CDM-600/L, CDM-625/A)	Off	Normal operation (no Deferred Maintenance Alarm)
	Orange	Deferred Maintenance Alarm
ONLINE	Green	Normal operation (Modem traffic active to/from User)
	Off	No modem traffic active to/from User
BRIDGED	Orange	Traffic modem is bridged or in "Hot Standby" – verifies that Redundant Modem is configured identically to this modem
	Off	Not bridged







## 6.1.2 Front Panel Keypad



The CRS-300 front panel keypad contains six individual key switches mounted behind a sealed membrane overlay. The keys have a positive "click" action for tactile feedback.

The keypad has an auto-repeat feature: If a key is held down for more than 1 second, the key action repeats automatically at the rate of 15 keystrokes per second. This is particularly useful when editing numeric fields.

These six switches function as follows:

Switch	Description	Function
	<b>UP ARROW</b>	Use this key to edit the value at the current cursor position, when appropriate. It also increments the value of a numeric field.
	<b>DOWN ARROW</b>	Use this key to edit the value at the current cursor position, when appropriate. Decrements the value of a numeric field.
	<b>RIGHT ARROW</b>	Use this key to move the displayed cursor to the right.
	<b>LEFT ARROW</b>	Use this key to move the displayed cursor to the left.
	<b>ENTER</b>	Use this key to accept an edited entry. Most menus prompt you to press this key by displaying the messages "PRESS ENTER", "ENTER", or "ENT".  Press <b>[ENT]</b> to <i>accept</i> the entry and display the previous menu.
	<b>CLEAR</b>	Use this key to exit the current operation and display the previous menu without accepting any configuration changes.  Press <b>[CLR]</b> to <i>reject</i> the entry and return to the previous menu.

### 6.1.3 Front Panel Vacuum Fluorescent Display (VFD)



The Front Panel **Vacuum Fluorescent Display (VFD)** is an active display showing two lines of 24 characters each. It produces an adjustable blue light. Compared to a **Liquid Crystal Display (LCD)**, it has greatly superior viewing characteristics and does not suffer problems of viewing angle or contrast.

On most menu displays, a flashing solid block cursor blinks at a once-per-second rate. This indicates the currently selected item, digit, or field:

```
CONFIG: MANUAL AUTO[ON]  
OPTIONS  REMOTE  ACTIVE
```

Where this solid block cursor would obscure the item being edited (for example, a numeric field) the cursor automatically changes to an underline cursor:

```
ACTIVE MODEMS:  (ENTER)  
1 2 3 - 5 6 - 8 - 10
```

If you were to display the same screen for weeks at a time, the display could become ‘burnt’ with this image. To prevent this, the unit has a ‘screen saver’ feature that activates after 1 hour. The top line of the display shows a customizable Switch ID. The bottom line shows the current status of the Switch, followed by ‘Press any key...’:

```
-----  
Press any key...
```

The message moves from right to left across the display, and then wraps around. Pressing any key restores the previous display.

#### 6.1.3.1 Opening Screen

```
COMTECH CRS-300 SWITCH  
for CDM-XXX modem vX.XX
```

A ‘welcome screen’ similar to what is pictured here displays whenever power is first applied to the unit. It identifies the modem and its current running firmware version. Press any key to access the top-level **SELECT:** menu.

### 6.1.3.2 Menu Structure

Figure 6-2 shows the menu structure of the CRS-300. The menu, branches, and applicable submenus are described in detail in the chapter sections that follow. Note also that chapter sections may refer to the old Recommended Standard (RS) designation rather than the new designation of the Electronic Industries Association (EIA).

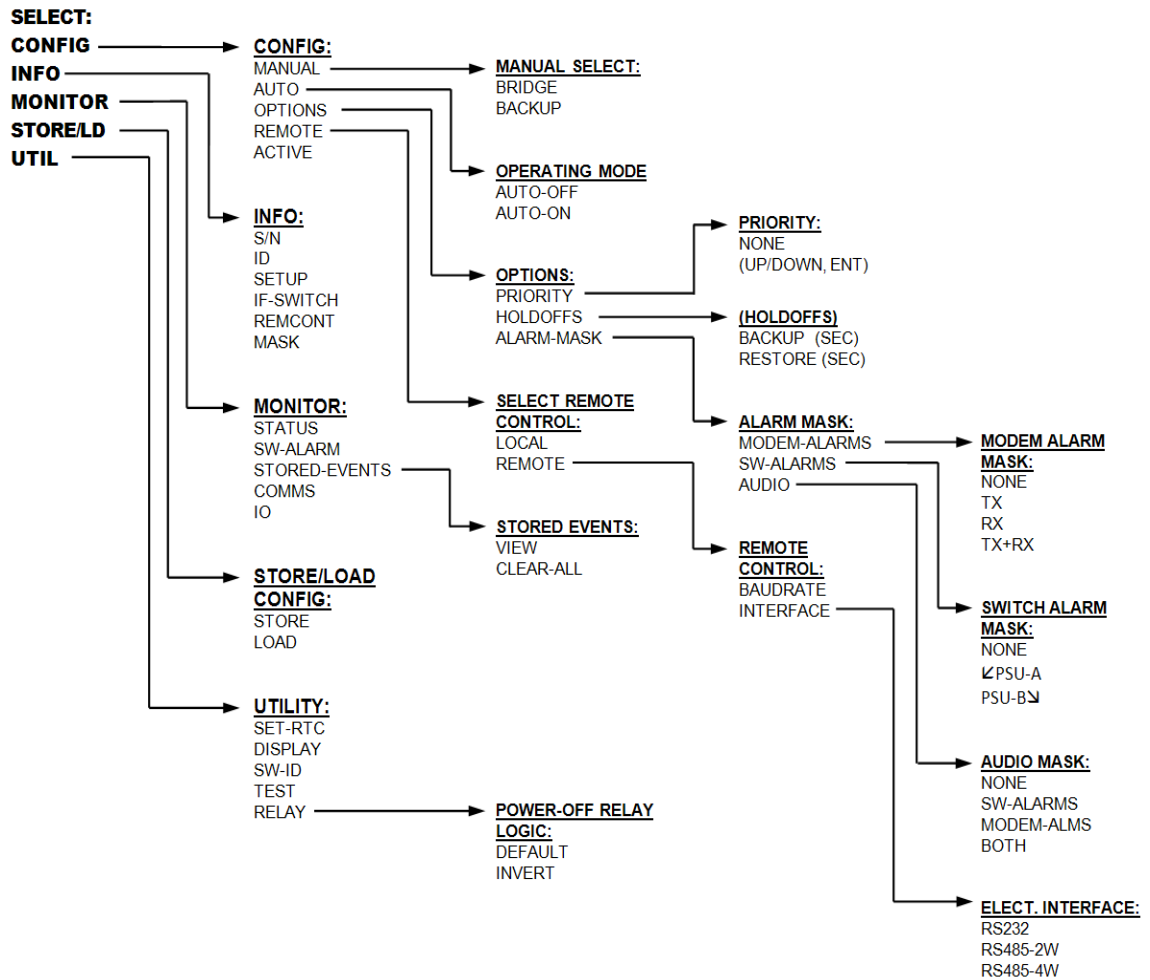


Figure 6-2. CRS-300 Menu Tree



## 6.2 Front Panel Operation

### 6.2.1 SELECT: (Top-Level) Menu

```
SELECT:  CONFIG  INFO
        MONITOR STORE/LD UTIL
```

Use the ◀ ▶ arrow keys to select from the choices shown, and then press [ENT]. The function of each menu branch (and the chapter section that provides information on that branch and its accompanying submenus) is as follows:

Selection	Sect.	Menu Branch Description
CONFIG	6.2.2	<b>(Configuration)</b> Permits you to fully configure the Switch.
INFO	6.2.3	<b>(Information)</b> Permits you to view information on the Switch, without having to go into configuration screens.
MONITOR	6.2.4	Permits you to monitor the status of the Switch and view the log of stored events for both the Switch and its attached modems.
STORE/LD	6.2.5	<b>(Store/Load)</b> Permits you to store and to retrieve up to 10 different Switch configurations.
UTIL	6.2.6	<b>(Utility)</b> Permits you to perform miscellaneous functions, such as setting the Real-time clock, adjusting the display brightness, etc.

### 6.2.2 SELECT: CONFIG (Configuration)

```
CONFIG:  MANUAL AUTO[OFF]
        OPTIONS REMOTE ACTIVE
```

Use the ◀ ▶ arrow keys to select from the choices shown, and then press [ENT]. The submenus available under the **CONFIG** menu branch are as follows:

Selection	Sect.	Menu Branch Description
MANUAL	6.2.2.1	Permits you to select which traffic MODEM the Switch should bridge or backup.
AUTO [OFF/ON]	6.2.2.2	Permits you to turn <b>AUTO</b> mode off or on. The currently selected state is always shown on this menu
OPTIONS	6.2.2.3	Permits you to set several operating parameters of the Switch that pertain to enabling or disabling the availability of Traffic Modems, the reporting of faults and time delays for responding to faults.
REMOTE	6.2.2.4	Permits you to define the remote control settings.
ACTIVE	6.2.2.5	Permits you to activate modems, if a TMI is present.



**The Switch may be monitored over the remote control bus at any time. When in Local mode, however, configuration parameters may only be changed through the**

front panel. Conversely, when in Remote mode, the unit may be monitored from the front panel, but configuration parameters may only be changed via the remote control bus.

### 6.2.2.1 CONFIG: MANUAL

```
MANUAL SELECT :  
BRIDGE : 02    BACKUP : 02
```

You may manually select which Traffic Modem is to be bridged or backed up. In **MANUAL** mode (**Auto** is **OFF**), both of these selections are available. Use the ◀ ▶ arrow keys to first select between **BRIDGE** or **BACKUP**. Then, use the ▲ ▼ arrow keys to scroll through all active Traffic Modems – the menu skips over any inactive modem slots. Press **[ENT]** to continue.

In **AUTO** mode, the Switch has control and will automatically backup any active Traffic Modem based on its fault relay activity. The **BACKUP** selection is unavailable for manual selection, but the modem being bridged may be changed. In this mode, the **MANUAL SELECT** display appears as follows:

```
MANUAL SELECT :  
BRIDGE : 02    BACKUP : AUTO
```

Use the ▲ ▼ arrow keys to select an active Traffic Modems – the menu skips over any inactive modem slots. Press **[ENT]** to configure.

In **BACKUP** mode, the Redundant Modem is online. In this case, you may not alter the bridge/backup state. Instead of the **MANUAL SELECT** menu, this message displays:

```
MANUAL SELECT :  
SWITCH IS IN AUTO MODE.
```

Press **[CLR]** or **[ENT]** to return to the previous menu.

The Switch learns and retains the configuration of all of the active modems in the setup. The Switch uses this configuration information to program the Redundant Modem to match the configuration of the modem being bridged.

### 6.2.2.2 CONFIG: AUTO (AUTO-OFF or AUTO-ON)

```
OPERATING MODE :  
AUTO-OFF    AUTO-ON (ENTER)
```

Use the ◀ ▶ arrow keys to select **AUTO-OFF** or **AUTO-ON**, and then press **[ENT]**.

When off (**MANUAL** mode), the Switch does not respond automatically to any modem faults and simply performs whatever manual setting you perform via the previous **MANUAL-SELECT** menu.

In **MANUAL** mode, the **STORED EVENT** indicator blinks to alert you that the Switch is effectively not in use.



The CDM-7XX modems have **Faults and Alarms**. For these modems, **AUTO Switch Mode** will react only to modem **Faults**; modem **Alarms** will be ignored.

### 6.2.2.3 CONFIG: OPTIONS

```
OPTIONS:      PRIORITY
             HOLDOFFS  ALARM-MASK
```

These options define how the Switch will react to various faults. Use the ◀ ▶ arrow keys to select from the choices shown, and then press [ENT].

#### 6.2.2.3.1 CONFIG: OPTIONS → PRIORITY

```
PRIORITY:     POSITION 2
              UP/DOWN, and then
ENTER
```

If one link is considered more important than all others, this feature enables you to prioritize that link. For example, if the Switch is in **AUTO** mode and it is already backing-up a link that is not a priority link. If the priority link now fails, the link will be restored regardless of its fault state. The priority link will now be bridged and then backed up.



Only activated TMI slots will be available for selection as the ▲ ▼ arrow keys are pressed.

#### 6.2.2.3.2 CONFIG: OPTIONS → HOLDOFFS

```
BACKUP HOLDOFF SEC: 05
RESTORE HOLDOFF SEC: 10
```

Use the ◀ ▶ arrow keys to switch between the **BACKUP** and **HOLDOFF** settings. Then, use the ▲ ▼ arrow keys to adjust the time (in seconds). Both **HOLDOFFS** can be set from 1 to 99 seconds.

Edit the **BACKUP** and **RESTORE HOLDOFF** times, and then press [ENT].

You may set the **HOLDOFFS** (delay times) between the Switch's modem alarm detection and its reaction to the event. These **HOLDOFFS** apply only when the Switch is in **AUTO** mode.

When an active modem exhibits an unmasked fault, the Switch bridges it with the Redundant Modem and checks that the latter is not also faulted. If there is no fault, the **BACKUP HOLDOFF** determines how long the Switch will wait before performing the actual backup, or switchover of traffic to the Redundant Modem.



If the CDM-Qx/QxL configuration includes Carrier-in-Carrier®, this **HOLDOFF** time should be no less than 8 seconds.

When the Switch is currently backing up a Traffic Modem and that offline modem's fault clears, the Switch continues to back it up until another active modem becomes faulted. In this case, the **RESTORE HOLDOFF** is the length of time that the originally faulted modem must stay unfaulted before the Switch automatically puts it back online so that the Redundant Modem becomes available to bridge the newly faulted modem.

### 6.2.2.3.3 CONFIG: OPTIONS → ALARM-MASK

```
ALARM MASK:  MODEM-ALARMS
SW-ALARMS  AUDIO  (ENTER)
```

Select **MODEM-ALARMS**, **SW-ALARMS**, or **AUDIO**, and then press **[ENT]**. The Switch logs and reacts to both its own faults and modem faults. Either type of faults may be masked using this submenu. In addition, an audible buzzer can be enabled as an additional indicator.

#### CONFIG: OPTIONS → ALARM-MASK → MODEM-ALARMS

```
MODEM ALARM MASK:  NONE
TX  RX  TX+RX  (ENTER)
```

Use the ◀ ▶ arrow keys to select from the choices shown, and then press **[ENT]**.

You may mask Transmit or Receive Traffic faults (or both) from being reacted to by the Switch. This not only prevents the Switch from performing **AUTO** mode functions when these modem faults are sensed, but also keeps the faults from being logged by the Switch.



These selections are global to all the modems. If masking of individual modem faults is desired, it should be done directly on the modem. Unmasked modem faults are logged on active modems only.

#### CONFIG: OPTIONS → ALARM-MASK → SW-ALARMS

```
SWITCH ALARM MASK:  NONE
⏏PSU-A  PSU-B⏏ (ENTER)
```

Use the ◀ ▶ arrow keys to select **NONE**, **⏏PSU-A**, or **PSU-B⏏**, and then press **[ENT]**.

You may select which of the plug-in power supply units to mask. Only one of the units can be masked at a time, if needed. This would normally be done if you choose to run with only one supply, or if you remove a faulty supply for service or replacement.

## CONFIG: OPTIONS → ALARM-MASK → AUDIO

```
AUDIO MASK: NONE SW-ALMS
MODEM-ALMS BOTH (ENTER)
```

Use the ◀ ▶ arrow to select from the choices shown, and then press [ENT].

For all unmasked Switch or modem alarms, you may select which alarm types should force the Switch to react with an audible buzzer located behind the front panel. In addition, a relay closure to ground activates on Pin 20 of the System Alarms connector so that you may attach other indicators.

### 6.2.2.4 CONFIG: REMOTE

```
SELECT REMOTE CONTROL:
LOCAL REMOTE (PRESS ENT)
```

Use the ◀ ▶ arrow keys to select **LOCAL** or **REMOTE**, and then press [ENT].

#### 6.2.2.4.1 CONFIG: REMOTE → LOCAL

When you select **LOCAL**, the Switch disables remote control, although remote monitoring is always possible.

#### 6.2.2.4.2 CONFIG: REMOTE → REMOTE

```
REMOTE CONTROL: BUADRATE
INTERFACE (PRESS ENTER)
```

Use the ◀ ▶ arrow keys to select **BAUDRATE** or **INTERFACE**, and then press [ENT].

#### CONFIG: REMOTE → REMOTE → BAUDRATE

```
REMOTE CONTROL: BUADRATE
INTERFACE (PRESS ENTER)
```

You may select the baud rate of the remote control bus, connected locally to the M&C computer. Use the ◀ ▶ arrow keys to change the baud rate. Values of 300, 1200, 2400, 4800, 9600 and 19200 baud are possible. Press [ENT] when done.



**This setting does not affect the internal communications between the Switch and the modems.**

## CONFIG: REMOTE → REMOTE → INTERFACE



The Electronic Industries Association (EIA) designations supersede the Recommended Standard (RS) designations.

```
ELECT. INTERFACE: RS232
RS485-2W   RS485-4W (ENT)
```

Use the ◀ ▶ arrow keys to select **RS232**, **RS485-2W** (2-wire), or **RS485-4W** (4-wire), and then press [ENT].

You will be further prompted to enter the bus address. In this example, EIA-232 mode is used and the bus address is fixed at 0:

```
IN RS232 MODE THE BUS
ADDRESS IS FIXED AT 0000
```

In EIA-485 2-wire or 4-wire mode, you may select an address:

```
EDIT SWITCH BUS ADDRESS:
3000   (PRESS ENTER)
```

The valid addresses are 1000, 3000, 5000 and 7000 only, as explained in **Chapter 7. SERIAL-BASED REMOTE PRODUCT MANAGEMENT** in this manual.



This setting does not affect the internal communications between the Switch and the modems.

### 6.2.2.5 CONFIG: ACTIVE (Activate Modems)

```
ACTIVE MODEMS: (ENTER)
1 2 3 - 5 6 - 8 9 10
```

Use the ◀ ▶ arrow keys to select which Traffic Modem to activate, and then use the ▲ ▼ arrow keys to activate or deactivate the modem.

A modem must be active in order for it to be available for bridge or backup. A hyphen (-) appears in place of the modem number if it is deactivated. If a Traffic Modem interface is not plugged into a slot, that position cannot be activated.

Once activated, the Switch expects that modem to be connected, and it polls the modem for status information.

When adding or removing a modem in an *operating* 1:N Switch system, it is important to keep the traffic safe, by preventing any contention in the system from an unsuppressed modem Tx carrier.

**Do these steps to add an additional Traffic Modem to the redundancy system:**

- 1) Attach all control, data and IF cables as explained in **Chapter 4. CABLES AND CONNECTIONS.**
- 2) Configure the modem and Switch as explained in **Chapter 5. MODEM, RMI/TMI, AND SWITCH CONFIGURATION.**

**Do these steps to remove a Traffic Modem that is not being backed up:**

- 1) Use the **CONFIG: ACTIVE** menu to de-activate the modem from its active state in the Switch configuration (use the ◀ ▶ arrow keys to select the pertinent modem (TMI) position, and then use the ▼ arrow key to de-activate that modem.
- 2) Power-down the modem.
- 3) Detach all cables.

**Do these steps to replace a faulted Traffic Modem that is being backed up by the Redundant Modem:**

- 1) Detach the IF cables of the faulted modem.
- 2) Power-down the modem.
- 3) Remove all other the cables and remove the modem.
- 4) Install the replacement modem.
- 5) Attach the power cord and power up the modem.
- 6) Attach control, data and IF cables as directed in **Chapter 4. CABLES AND CONNECTIONS.**
- 7) Configure the modem as directed in **Chapter 5. MODEM, RMI/TMI AND SWITCH CONFIGURATION.**
- 8) The new Traffic Modem should lock as it is bridging the Redundant Modem. The Switch will then ready and able to manage any subsequent faults.
- 9) If desired, you can go to **MANUAL** mode, switch the active traffic over from the Redundant Modem to the Traffic Modem, and then return to **AUTO** mode.

## 6.2.3 SELECT: INFO (Information)

```
INFO:  S/N  ID  SETUP  
IF-SWITCH  REMCONT  MASK
```

The **INFO:** selections are **read-only** information screens, the purpose being to provide you with the current Switch configuration information without risking inadvertent alterations.

Use the ◀ ▶ arrow keys to select from the choices shown, and then press [ENT].

**Typical for all nested screens:** Press [ENT] or [CLR] to return to the previous menu.

### 6.2.3.1 INFO: S/N

```
SWITCH S/N:  
1234567890
```

This screen displays the unique serial number assigned to this unit by Comtech EF Data.

### 6.2.3.2 INFO: ID

```
SWITCH ID:  
-----
```

This screen displays the user-defined Switch ID string that is entered via the **UTILITY: SWITCH-ID** submenu.

### 6.2.3.3 INFO: SETUP

```
TM: 1 2 3 4 5 - 7 - 9 10  
AUTO:OFF BKUP:05 REST:20
```

This screen displays some of the settings configured in the **CONFIG: OPTIONS** menu. Active Traffic Modems are listed on the top line. **AUTO** mode status and the **BACKUP** and **RESTORE HOLDOFF** times listed on the bottom.

### 6.2.3.4 INFO: IF-SWITCH

```
TRANSPONDER SWITCH IS  
ABSENT
```

This screen displays whether or not a CRS-280/L IF Transponder Switch is connected to the CRS-300. When an IF Switch is present, the second line will indicate "**PRESENT**", and any offline modem – Redundant or Traffic – will not have its Tx IF muted by the CRS-300.



### 6.2.3.5 INFO: REMCONT (Remote Control Info)

```
REM CNTL: ON      RS232  
ADDR:0000  9600 BAUD 8N1
```

This screen displays if the unit is in **LOCAL** or **REMOTE** mode; identifies the selected electrical interface type; displays the unit address; identifies the baud rate; and displays the data format.

### 6.2.3.6 INFO: MASK (Alarm Mask Info)

```
ALARMS MASKED: MODEM-TX  
MODEM-RX  ↵PSU-A  PSU-B↵
```

This screen displays the alarms that are currently masked. If an alarm is not masked, a blank space appears in the relevant screen position. Power Supplies 'A' and 'B' cannot be masked at the same time, but are shown together here to indicate their relative positions on the screen.

## 6.2.4 SELECT: MONITOR

```
MONITOR:  STATUS SW-ALARM  
STORED-EVENTS  COMMS  IO
```

Use the ◀ ▶ arrow keys to select from the choices shown, and then press [ENT].

### 6.2.4.1 MONITOR: STATUS

```
TM 02 IS BRIDGED BY RM  
BACKUP HOLDOFF: 05 SEC
```

This display shows the bridged or backup status of the Switch:

- When the Redundant Modem is not backing up any of the Traffic Modems, the display will show which Traffic Modem is currently being bridged by the Redundant Modem.
- If **AUTO** mode is on, it will also show the backup holdoff time that is employed should the bridged Traffic Modem fail.
- If **AUTO** mode is off, the second line displays "OFF".
- When the Switch has taken the bridged Traffic Modem offline and replaced it with the Redundant Modem (whether done manually or automatically), the display changes as follows:

```
TM 02 IS BRIDGED BY RM  
RESTORE HOLDOFF: 05 SEC
```

The **RESTORE HOLDOFF** time is shown on the second line if **AUTO** mode is on.

## 6.2.4.2 MONITOR: SW-ALARM

The following are examples of possible Switch status displays, along with suggestions to assist you in diagnosing the reason for the fault.

```
SWITCH ALARM:  NONE
```

*There are no faults.* The “Unit Status” front panel LED should be **GREEN**.

```
SWITCH ALARM:  -12V PS-B  
                ↘ IS UNDERVOLTAGE
```

*There is a fault.* Power supply “B” is under voltage. The “Unit Status” front panel LED will be **RED**.

### Suggestions:

- Ensure power supply power cord is connected and the power switch is ON.
- Replace defective power supply module.

If the second power supply module is not needed, you can mask this Alarm.

```
SWITCH ALARM:  RM TIMEOUT  
                RM I/O TIMEOUT
```

*There is a fault.* Communication has been lost to the Redundant Modem. The “Unit Status” front panel LED will be **RED**.

### Suggestions:

- Check cable connections – see **Chapter 4. CABLES AND CONNECTIONS**.
- Check modem configurations – see **Chapter 5. MODEM, RMI/TMI, AND SWITCH CONFIGURATION**.

```
SWITCH ALARM:  RM TIMEOUT  
                MGC refused, code:12 TFT
```

*There is a fault.* COMMs are good to the Redundant Modem, but the configuration of the bridged Traffic Modem cannot be configured into the Redundant Modem. The “Unit Status” front panel LED will be **RED**.

**Suggestion:** Ensure the most capable modem – with regard to FAST options, installed options, e.g. Turbo card, firmware version, and hardware revision – is used as the Redundant Modem.

The code indicates the parameter within the MGC configuration string that is causing the Redundant Modem to refuse it.

The three-letter instruction code is indicated also to assist decoding the following problem parameters:

- **For the CDM-570/A or CDM-570L/AL modem**, the code is the decimal number indicating the fault parameter within its MGC configuration code:

00		NO ERROR	01	ITF	Interface
02	LBO	T1 Line Build-Out	03	FRM	Framing mode
04	TFQ	Tx Frequency	05	TFT	Tx FEC Type
06	TMD	Tx Modulation	07	TCR	Tx FEC Code Rate
08	TDR	Tx Data Rate	09	TSI	Tx Spectrum Invert
10	TSC	Tx Scrambler state	11	TPL	Tx Power Level
12	TCK	Tx Clock	13	TDI	Tx Data Invert
14	TXO	Tx Carrier State	15	AUP	AUPC enable
16	APP	AUPC parameters	17	WUD	Warm-Up Delay
18	RFQ	Rx Frequency	19	RFT	Rx FEC Type
20	RMD	Rx Modulation	21	RCR	Rx FEC Code Rate
22	RDR	Rx Data Rate	23	RSI	Rx Spectrum Invert
24	RDS	Rx Descrambler state	25	RDI	Rx Data Invert
26	RSW	Rx Sweep Width	27	EBA	Eb/No Alarm point
28	RBS	Rx Buffer Size/enable	29	ERF	External Reference setting
30	EFM	EDMAC Framing mode	31	ESA	EDMAC Slave Address range
32	TST	Test mode	33	MSK	Alarm Masks
34	RTS	Request-To-Send control	35	SSI	Statistics Sample Interval

- **For the CDM-Qx/QxL modem**, the code is the decimal number indicating the fault parameter within its MGC configuration code:

00		NO ERROR	01	ITF	Interface
02	LBO	T1 Line Build-Out	03	FRM	Framing mode
04	TFQ	Tx Frequency	05	TFT	Tx FEC Type
06	TMD	Tx Modulation	07	TCR	Tx FEC Code Rate
08	TDR	Tx Data Rate	09	TSI	Tx Spectrum Invert
10	TSC	Tx Scrambler state	11	TPL	Tx Power Level
12	TCK	Tx Clock	13	TDI	Tx Data Invert
14	TXO	Tx Carrier State	15	AUP	AUPC enable
16	APP	AUPC parameters	17	WUD	Warm-Up Delay
18	TXC	Tx common output state	19	TRS	Tx Reed-Solomon
20	TXA	Tx roll-off (alpha) factor	21	TCI	Tx Data Clock Invert
22	RFQ	Rx Frequency	23	RFT	Rx FEC Type
24	RMD	Rx Modulation	25	RCR	Rx FEC Code Rate
26	RDR	Rx Data Rate	27	RSI	Rx Spectrum Invert
28	RDS	Rx Descrambler state	29	RDI	Rx Data Invert
30	RSW	Rx Sweep Width	31	EBA	Eb/No Alarm point
32	BCS	Rx Buffer clock source	33	RRS	Rx Reed-Solomon
34	RBS	Rx Buffer size/enable	35	RCI	Rx Data Clock Invert
36	ERF	External Reference setting	37	EFM	EDMAC Framing mode
38	ESA	EDMAC Slave Address range	39	TST	Test mode (read-only)
40	MSK	Alarm Masks	41	RTS	Request-To-Send control
42	SSI	Statistics Sample Interval	43	CNM	CnC Mode
44	CFO	CnC Frequency Offset	45	CSD	CnC Min/Max Search Delay
46	CRA	CnC Re-acquisition Time			

- **For the CDM-600/L modem**, the code is the hex value of the position of the fault parameter within the MGC configuration code.

00		NO ERROR	01	TFQ	Tx Frequency
09	TDR	Tx Data Rate	12	TFT	Tx FEC Type
13	TRS	Tx Reed Solomon type	14	TCR	Tx FEC Code Rate
15	TMD	Tx Modulation	16	TSI	Tx Spectrum Inversion
17	TSC	Tx Scrambler state	18	TPL	Tx Power Level
1C	AUP	AUPC enable	1D	APP	AUPC parameters
23	TCK	Tx Clock source	24	TXO	Tx Carrier state
25	TIT	Tx Interface Type	26	TTC	Tx Ternary Code
27	TFM	Tx Framing Mode	28	TIP	Tx IF Impedance
29	RFQ	Rx Frequency	31	RDR	Rx Data Rate
3A	RFT	Rx FEC Type	3B	RRS	Rx Reed Solomon type
3C	RCR	Rx FEC Code Rate	3D	RMD	Rx Modulation
3E	RSI	Rx Spectrum Inversion	3F	RDS	Rx Descrambler state
40	RSW	Rx Sweep Width	42	RCK	Rx Clock source
43	EBA	EbNo Alarm point	47	RBS	Rx Buffer Size
4C	RIT	Rx Interface Type	4D	RTC	Rx Ternary Code
4E	RFM	Rx Framing Mode	4F	RIP	Rx IF Impedance
50	EFM	Unit EDMAC Mode	51	ESA	EDMAC Slave Address
55	TST	Unit Test Mode	56	MSK	Unit Alarm Mask
5C	EFR	External Freq Ref	5D	SSI	Statistics Sampling Interval
5E	RTE	Rx Terrestrial Alarm Enable	5F	TTA	Tx Terrestrial Alarm Mask
60	ODU	ODU comms Enable	61	TBA	Tx Backward Alarms
65	RBA	Rx Backward Alarms	69	TVL	Tx audio Volume
6D	RVL	Rx audio Volume	71	DTY	Drop Type
72	ITY	Insert Type	73	TET	Tx ESC Type - 64k or 2 audio
74	RET	Rx ESC Type - 64k or 2 audio	75	ITD	Invert Tx Data
76	IRD	Invert Rx Data			

**SWITCH ALARM: MODEM COMMS  
PROBLEM, POSITION 2**

**There is a fault.** There is a problem with the I/O communications with Traffic Modem 2. The “Unit Status” front panel LED will be **RED**.

**Suggestions:**

- Check cable connections – see **Chapter 4. CABLES AND CONNECTIONS**.
- Check modem configurations – see **Chapter 5. MODEM, RMI/TMI, AND SWITCH CONFIGURATION**.

**SWITCH ALARM: TMI: I/F  
MISMATCH, POSITION 2**

**There is a fault.** There is a mismatch of data interface type between what has been selected in the modem menu and the TMI type that is connected to that Traffic Modem. The “Unit Status” front panel LED will be **RED**.

**Suggestion:** Ensure the modem interface type is compatible with the TMI being used. The CDM-600/Ls and CDM-625/As have both TX and RX interface types. CDM-570/As and CDM-570L/ALs have only one unit interface type each. Either edit the modem interface setting(s) or swap the TMI.

### 6.2.4.3 MONITOR: STORED-EVENTS

```
STORED EVENTS: VIEW  
CLEAR-ALL (PRESS ENTER)
```

Use the ◀ ▶ arrow keys to select **VIEW** or **CLEAR-ALL**, and then press **[ENT]**.

#### 6.2.4.3.1 MONITOR: STORED-EVENTS → VIEW

```
LOG23: 26/01/14 10:37:32  
FT-06 RX ALARM (UP/DN)
```

Use the ▲ ▼ arrow keys to scroll backwards or forwards through the entries in the event log. Press **[ENT]** or **[CLR]** to return to the previous menu.

When a fault condition (indicated in the above example as FT) occurs, it is time-stamped and put into the log. The event log can store up to 98 events. Note that the date is shown in **DD/MM/YY** format, in accordance with international convention.

Likewise, when the fault condition clears (FT changes to OK), this is also recorded, as per this example:

```
LOG25: 26/01/14 10:37:45  
OK-06 RX ALARM (UP/DN)
```

Next to the FT/OK indicator is a number/code for the faulted unit: the TM slot number (1 through 10), RM (for Redundant Modem) or SW (for the Switch).

#### 6.2.4.3.2 MONITOR: STORED-EVENTS → CLEAR-ALL

When you select **CLEAR-ALL**, the Switch clears the event log returns you to the previous menu. However, if there are faults present on the unit at this time, the Switch generates new log entries for those faults.

#### 6.2.4.4 MONITOR: COMMS (Communications State)

```
GOOD COMMS WITH MODEMS:  
1 2 3 - 5 - 7 8 - 10
```

This display shows that the state of communications between the Switch and modems. In this example, the Switch has good monitoring I/O communications with the indicated modems.

### 6.2.4.5 MONITOR: IO

```
<0100/LRS?  
>0100/LRS=1
```

This display shows actual communication strings between the Switch and the modems:

- **Upper line** = Switch controller's outbound messages
- **Lower line** = Modem's inbound responses



**These are configurations for the Switch itself, not the modems to which it is attached.**

**When in this mode, communication is slowed down to enable viewing of messages. This display should therefore be used for troubleshooting purposes only.**

### 6.2.5 SELECT: STORE/LD (Store or Load Configuration)

```
STORE/LOAD CONFIG:  
STORE  LOAD  (PRESS ENTER)
```

Use the ◀ ▶ arrow keys to select **STORE** or **LOAD**, and then press [ENT]. You can store or load up to 10 different configurations in the Switch's non-volatile memory.



**These are configurations for the Switch itself, not the modems to which it is attached.**

#### 6.2.5.1 STORE/LD: STORE

```
STORE CONFIGURATION TO  
LOCATION: 10 (ENTER)
```

Use the ▲ ▼ arrow keys to select the location to where the current configuration is to be loaded, and then press [ENT]. Locations 1 through 10 are available. If the selected location does not contain a previously stored configuration, this message displays:

```
YOUR CONFIGURATION HAS  
BEEN STORED! (ENTER)
```

Press [ENT] or [CLR] to return to the previous menu. If, however, the selected location contains a previously stored configuration, this message displays:

```
WARNING! LOC 10 CONTAINS  
DATA! OVERWRITE? NO YES
```

Use the ◀ ▶ arrow keys to select **NO** or **YES**, and then press **[ENT]**. If you select **YES**, this will overwrite the existing configuration at the selected location.

### 6.2.5.2 STORE/LD: LOAD

```
LOAD CONFIGURATION FROM  
LOCATION: 10 (ENTER)
```

Use the ▲ ▼ arrow keys to select the location from where to load the desired configuration, and then press **[ENT]**. Locations 1 through 10 are available. If the location contains a valid stored configuration, this message displays:

```
THE NEW CONFIGURATION  
HAS BEEN LOADED (ENTER)
```

Press **[ENT]** or **[CLR]** to return to the previous menu. If, however, the selected location does **not** contain a previously stored configuration, this message displays:

```
WARNING! LOC 10 CONTAINS  
NO DATA! (ENTER)
```

Press **[ENT]** or **[CLR]** to return to the previous menu.

### 6.2.6 SELECT: UTILITY

```
UTILITY: SET-RTC DISPLAY  
SWITCH-ID TEST RELAY (ENT)
```

Use the ◀ ▶ arrow keys to select from the choices shown, and then press **[ENT]**. This submenu permits you to select from a number of different utility functions.

#### 6.2.6.1 UTILITY: SET- RTC (Set Real-Time Clock)

```
EDIT REAL TIME CLOCK:  
12:00:00 24/04/14 (ENT)
```

**To edit the time and date:** Use the ◀ ▶ arrow keys to select a digit, and then use the ▲ ▼ arrow keys to edit that value. Press **[ENT]** when done. Note that the date is shown in **DD/MM/YY** format, in accordance with international convention.

#### 6.2.6.2 UTILITY: DISPLAY (Display Brightness)

```
EDIT DISPLAY BRIGHTNESS:  
100% (PRESS ENTER)
```

Use the ▲ ▼ arrow keys to select a VFD brightness level of **25%**, **50%**, **75%** or **100%**, and then press **[ENT]**.

### 6.2.6.3 UTILITY: SWITCH-ID

```
EDIT SWITCH ID:  
**CRS-300 TEST MESSAGE**
```

**To edit the Switch ID string:** Use the ◀ ▶ arrow keys to select the cursor position on the bottom line, and then use the ▲ ▼ arrow keys to edit the character in that position. You may use the following characters:

*[space] ( ) \* + - , . / 0 through 9 and A through Z*

A maximum of 24 characters are allowed. Press [ENT] when done.

### 6.2.6.4 UTILITY: TEST

This is an excellent method to test the whole system before setting the Switch for automatic mode.

Once you select this screen, the Switch suspends normal system polling and initiates a test:

```
CONFIG TESTING.....2  
TM#:          1 OK
```

```
TEST COMPLETE.  
CHECK 2.
```

The total configuration of each activated modem is configured into the Redundant Modem in sequence. If any configuration is not accepted, a fault will be shown on the display.

Press [ENT] or [CLR] to return to the top-level (main) menu.

### 6.2.6.5 UTILITY: RELAY

```
POWER-OFF RELAY LOGIC:  
DEFAULT INVERT (ENT)
```

The alarm relay condition terms “Normally Open” and “Normally Closed” are easily misinterpreted. To facilitate customer connection to existing external equipment, you may use this menu to invert the logic of the external relay condition.

Use the ◀ ▶ arrow keys to select **DEFAULT** or **INVERT**, and then press [ENT].



# Chapter 7. SERIAL-BASED REMOTE PRODUCT MANAGEMENT

---

## 7.1 Overview

The CRS-300 1:10 Redundancy Switch serial remote product management interface is an electrical interface that is either an EIA-485 multi-drop bus (for the control of multiple devices) or an EIA-232 connection (for the control of a single device). The interface transmits data in asynchronous serial form, using ASCII characters. This data consists of control and status information, transmitted in packets of variable length in accordance with the structure and protocol explained later in this chapter.



See Sect. 3.2.1.3 Remote Control Connector, DB-9M in Chapter 3. SWITCH CONNECTORS AND PINOUTS for the EIA-232 and EIA-485 connector pinouts Table 3-2.

---

## 7.2 EIA-485

For applications where multiple devices are to be monitored and controlled, a full-duplex (or 4-wire plus ground) EIA-485 is preferred. Half-duplex (2-wire plus ground) EIA-485 is possible, but is not preferred. In full-duplex EIA-485 communication, there are two separate, isolated, independent, differential-mode twisted pairs, each handling serial data in different directions.

It is assumed that a 'Controller' device (a PC or dumb terminal) transmits data in a broadcast mode via one of the pairs. Multiple 'Target' devices are connected to this pair, and all simultaneously receive data from the Controller. The Controller is the only device with a line-driver connected to this pair – the Target devices have only line-receivers connected.

In the other direction, on the other pair each Target has a tri-state line driver connected, and the Controller has a line-receiver connected. All the line drivers are held in high-impedance mode until one (and only one) Target transmits back to the Controller. Each Target has a unique address, and each time the Controller transmits, the address of the intended recipient Target is included in a framed 'packet' of data. All of the Targets receive the packet, but only one (the intended) will reply. The Target enables its output line driver and transmits its return data packet back to the Controller in the other direction, on the physically separate pair.

**EIA-485 (full duplex) summary:**

- Two differential pairs – one pair for Controller-to-Target, one pair for Target-to-Controller.
- Controller-to-Target pair has one line driver (Controller), and all Targets have line-receivers.
- Target-to-Controller pair has one line receiver (Controller), and all Targets have Tri-State drivers.

---

### **7.3 EIA-232**

This is a much simpler configuration in which the Controller device is connected directly to the Target via a two-wire-plus-ground connection. Controller-to-Target data is carried, via EIA-232 electrical levels on one conductor, and Target-to-Controller data is carried in the other direction on the other conductor.

---

### **7.4 Rules for Remote Serial Communications with the CRS-300**

- 1) Always wait for a response (up to 15 seconds) from the CRS-300 before sending the next query or command.
- 2) If a "time-out" response ('~') is sent from the CRS-300, the user must resend the previous command. The '~' response indicates that a pass-through command to a modem/transceiver attached to the CRS-300 has "timed-out" and there was no response from the other device. During this wait, do not communicate with the CRS-300. After the '~' response is sent by the CRS-300, it is now ready to receive a message again. The CRS-300 knows to wait different times for the different messages it is sending to modems:
  - Status queries (no commands) are fast, (typically less than 333 ms).
  - Configuration changes (commands) take longer and vary by modem type.

- Individual commands responses are faster than those to global commands (MGC). More parameters require more time.
- A pass-through command is passed with little inspection by the switch, but remember the modem being addressed may be at the distant end of an EDMAC link! Types of pass-through commands:
  - To a local modem;
  - To a modem at the distant end (EDMAC);
  - To a local BUC or transceiver connected to a local modem;
  - To a distant end BUC or transceiver through the distant end modem.

---

## 7.5 Basic Protocol

Whether in EIA-232 or EIA-485 mode, all data is transmitted as asynchronous serial characters, suitable for transmission and reception by a Universal Asynchronous Receiver/Transmitter (UART). The asynchronous character format is 8-N-1 (8 data bits, no parity, 1 stop bit). The baud rate may vary from 1200 to 57600 baud.

All data is transmitted in framed packets. The Controller is in charge of the process of monitor and control, and is the only device that is permitted to initiate, at will, the transmission of data. Targets are only permitted to transmit when they have been specifically instructed to do so by the Controller.

All bytes within a packet are printable ASCII characters, less than ASCII code 127. In this context, the Carriage Return and Line Feed characters are considered printable.

All messages from Controller-to-Target require a response, with one exception: This will be either to return data that has been requested by the Controller, or to acknowledge reception of an instruction to change the configuration of the Target. The exception to this is when the Controller broadcasts a message (such as Set Time/Date) using Address 0, when the Target is set to EIA-485 mode.

## 7.5.1 Packet Structure

The exchange of information is transmitted, Controller-to-Target and Target-to-Controller, in ‘**packets**’. Each packet contains a finite number of bytes consisting of printable ASCII characters, excluding ASCII code 127 (DELETE).

In this context, the Carriage Return and Line Feed characters are considered printable. With one exception, all messages from Controller-to-Target require a response – this will be either to return data that has been requested by the Controller, or to acknowledge reception of an instruction to change the configuration of the Target.

Controller-to-Target						
Start of Packet	Target Address	Address Delimiter	Instruction Code	Code Qualifier	Optional Arguments	End of Packet
< ASCII code 60 (1 character)	(4 characters)	/ ASCII code 47 (1 character)	(3 characters)	= or ? ASCII codes 61 or 63 (1 character)	(n characters)	Carriage Return ASCII code 13 (1 character)

**Example:** <0000/RSH=30{CR}

Target-to-Controller						
Start of Packet	Target Address	Address Delimiter	Instruction Code	Code Qualifier	Optional Arguments	End of Packet
> ASCII code 62 (1 character)	(4 characters)	/ ASCII code 47 (1 character)	(3 characters)	=, ?, !, or * ASCII codes 61, 63, 33, or 42 (1 character)	(From 0 to n characters)	Carriage Return, Line Feed ASCII codes 13,10 (2 characters)

**Example:** >0000/BBU=107{CR}{LF}

### 7.5.1.1 Start of Packet

- **Controller-to-Target:** This is the character ‘<’ (ASCII code 60).
- **Target-to-Controller:** This is the character ‘>’ (ASCII code 62).

The ‘<’ and ‘>’ characters indicate the start of packet. They may not appear anywhere else within the body of the message.

---

## 7.5.1.2 Target Address

While up to 9,999 devices can be uniquely addressed, connection to the CRS-300 imposes some basic limitations:

- In EIA-232 applications, the Switch address is fixed at 0000.
- In EIA-485 applications, the Switch may be set to an address of 1000, 3000, 5000 or 7000. This allows up to four Switches to be connected on the same bus.
- The 11 modems that may be connected to the Switch may be accessed for remote monitor & control through the Switch via virtual addresses. The details of this addressing scheme is shown in **Appendix C. ADDRESSING SCHEME INFORMATION**. Valid remote commands and queries that can be sent to the modems via the Switch depend upon the modem protocol and the installed options. Consult the appropriate modem *Installation and Operation Manual* for further information.



**Regardless of the Switch COMMs being set up for either EIA-232 or EIA-485 mode, the internal link between the Switch and the modems is fixed (these examples refer to the old Recommended Standard (RS) designation rather than the new designation of the Electronic Industries Association (EIA)):**

- For CDM-570/A, CDM-570L/AL, CDM-600L modems:  
*RS-232, 9600 baud, 8-N-1, address 0*
- For SLM-5650/5650A modems:  
*TTL Switch, 9600 baud, 8-N-1, address N/A*
- For CDM-Qx/QxL modems:  
*RS-485, 9600 baud, 8-N-1, correct address*  
**(see Appendix C. ADDRESSING SCHEME INFORMATION)**

The Controller sends a packet with the address of a Target - the destination of the packet. When the Target responds, the address used is the same address, to indicate to the Controller the source of the packet. The Controller does not have its own address.

The Comtech SatMac application software (Version 3.6 or higher) can monitor and control a CRS-300 redundancy system. The address scheme details are shown in **Appendix C. ADDRESSING SCHEME INFORMATION**.

There also are address restrictions for distant-end modems (being accessed by EDMAC) and Comtech transceivers, connected either locally or at the distant-end of a link. See **Appendix C. ADDRESSING SCHEME INFORMATION** for detailed addressing information and diagrams.

---

### 7.5.1.3 Address Delimiter

This is the “forward slash” character '/' (ASCII code 47).

---

### 7.5.1.4 Instruction Code

This is a three-character alphabetic sequence, which identifies the subject of the message. Wherever possible, the instruction codes have been chosen to have some significance – e.g., **TFQ** for transmit frequency, **RMD** for receive modulation type, etc. This aids in the readability of the message, should it be displayed in its raw ASCII form. Only upper case alphabetic characters may be used (A-Z, ASCII codes 65 through 90).

---

### 7.5.1.5 Instruction Code Qualifier

This is a single character, which further qualifies the preceding instruction code. Instruction Code Qualifiers obey the following rules:

1) **From Controller-to-Target**, the only permitted values are:

Code Qualifier	Description
= (ASCII code 61)	'=' is used as the Assignment Operator (AO) and is used to indicate that the parameter defined by the preceding byte should be set to the value of the argument (s) which follow it. <b>For example</b> , BKH=12 would mean 'set the Back-up Hold-Off time to 12 seconds.'
? (ASCII code 63)	'?' is used as the Query Operator (QO) and is used to indicate that the Target should return the current value of the parameters defined by the preceding byte. <b>For example</b> , BKH? means 'what is the current value of Back-up Hold-Off time?'

2) **From Target-to-Controller**, the only permitted values are:

Code Qualifier	Description
= (ASCII code 61)	The '=' qualifier is used in two ways: a. If the Controller sends a query to a Target ( <b>for example</b> , BKH? means 'what is the current value of Back-up Hold-Off time?'), the Target responds with <b>BKH=xx</b> (where <b>xx</b> represents the time, in seconds, in question). b. If the Controller sends a <i>valid</i> command to set a parameter to a particular value, then the Target responds with <b>BKH=</b> (with no message arguments).

Code Qualifier	Description
? (ASCII code 63)	If the Controller sends an <i>invalid</i> command to set a parameter to a particular value, then the Target responds with, <b>for example, BKH?</b> (with no message arguments). This indicates that there was an error in the message sent by the Controller.
! (ASCII code 33)	If the Controller sends a command that the Target does not recognize, the Target responds by echoing the invalid instruction, followed by the '!' character. <b>For example: XYZ!</b>
* (ASCII code 42)	If the Controller sends a command to set a parameter to a particular value, and the value sent is valid BUT the modem will not permit that particular parameter to be changed at this time, the Target responds with, <b>for example, BKH*</b> (with no message arguments).
# (ASCII code 35)	If the Controller sends a correctly formatted command BUT the Target is in Local Mode, it will not allow reconfiguration and responds with, <b>for example, BKH#</b> (with no message arguments).
~ (ASCII code 126)	If a message was sent via the Switch to an attached modem or ODU, the message was transmitted transparently through the Switch. In the event of the other device not responding, the Switch would generate a response e.g. 0100/MGC~ indicating that it had finished waiting for a response and was now ready for further COMs.

---

### 7.5.1.6 Optional Message Arguments

Arguments are not required for all messages. Arguments are ASCII codes for the characters 0 to 9 (ASCII codes 48 to 57), A to Z (ASCII codes 65 to 90), period (ASCII code 46), and comma (ASCII code 44).

---

### 7.5.1.7 End Of Packet

- **Controller-to-Target:** This is the 'Carriage Return' character (ASCII code 13).
- **Target-to-Controller:** This is the two-character sequence 'Carriage Return', 'Line Feed' (ASCII codes 13 and 10). Both indicate the valid termination of a packet.

## 7.6 Remote Commands and Queries

Where Column 'C' = Command; Column 'Q' = Query: Columns marked (X) indicate Command only, Query only, or Command/Query for Instruction Code.

Instr Code	C	Q	Page
AAM	X	X	7-9
ACT	X	X	7-9
AMQ		X	7-9
BBU	X	X	7-9
BKH	X	X	7-9
CAE	X		7-9
CLD	X		7-10
CST	X	X	7-10
DAY	X	X	7-10
EID		X	7-10
FLT		X	7-11
LRS	X	X	7-11
MAM	X	X	7-11
MOD		X	7-12

Instr Code	C	Q	Page
NUE		X	7-12
OPM	X	X	7-12
PRI	X	X	7-12
RNE		X	7-13
RSH	X	X	7-13
SAM	X	X	7-14
SDT	X	X	7-14
SGC	X	X	7-14
SID	X	X	7-14
SNO		X	7-15
SWR		X	7-15
TIM	X	X	7-15
XMI		X	7-16

Note: The following Instruction Code Qualifiers are used in the 'Response to Command' column (see Sect. 7.5.1.5)	
Code	Meaning
=	Message OK
?	Received OK, but invalid arguments found
!	Unknown command
*	Message OK, but not permitted in <b>Current</b> mode
#	Message OK, but only permitted in <b>Remote</b> mode
~	Timed out a pass-through message



Parameter Type	Command (Code and qualifier)	Arguments for Command or Response to Query	Description of Arguments (Note that all arguments are ASCII numerical codes, that is, ASCII codes between 48 and 57)	Response to Command (Target-to-Controller)	Query (Code and qualifier)	Response to query (Target-to-Controller)
Audio Alarm Mask	AAM=	1 byte, numerical	Command or Query. Where <b>x</b> indicates the Audio alarm mask: 0 = no faults masked (audio enabled in response to any fault) 1 = Switch faults masked 2 = Modem faults masked 3 = All faults masked (audio never enabled)	AAM= (message OK) AAM? (received OK, but invalid arguments found) AAM# (message OK, but only permitted in Remote mode)	AAM?	AAM=x (see Description of Arguments)
Active Modems	ACT=	10 bytes, numerical	Command or Query. Where <b>x</b> is the active state of all 10 Traffic Modems: 0 = de-activate Traffic Modem (except if in back-up) 1 = activate Traffic Modem Redundant modem is always active.	ACT= (message OK) ACT? (received OK, but invalid arguments) ACT* (message OK, but not permitted in current mode)	ACT?	ACT=xxxxxxxx (see Description of Arguments)
Active Modem Query	N/A	10 bytes, numerical	Query only. Where <b>x</b> indicates the state of all 10 Traffic Modems: 0 = TMI not present. Modem cannot be activated. 1 = TMI present, but modem not activated. 2 = TMI present, modem activated and responding. 3 = TMI present, modem activated but not responding.	N/A	AMQ?	AMQ=xxxxxxxx (see Description of Arguments)
Bridged or Backed-up Modem Number	BBU=	3 bytes, numerical	Command or Query. The bridge/back-up state, followed by the selected TM to be acted on, where: <b>x</b> is 0 = bridge 1 = back-up (only possible when in manual mode); and <b>yy</b> is 01-10 for modem number	BBU= (message OK) BBU? (received OK, but invalid arguments) BBU* (message OK, but not permitted in current mode)	BBU?	BBU=xyy (see Description of Arguments)
Backup Holdoff Time	BKH=	2 bytes, numerical	Command or Query. The backup holdoff time is the delay when auto mode prepares to backup a faulted modem, where: 01-99 = # of seconds delay after Redundant Modem has acquired Traffic Modem's configuration before online swap actually takes place.	BKH= (message OK) BKH? (received OK, but invalid arguments) BKH# (message OK, but only permitted in Remote mode)	BKH?	BKH=xx (see Description of Arguments)
Clear All Stored Events	CAE=	None	Command only. Instructs the unit to clear all Stored Events. This command takes no arguments.	CAE= (message OK) CAE# (message OK, but only permitted in Remote mode)	N/A	N/A

Parameter Type	Command (Code and qualifier)	Arguments for Command or Response to Query	Description of Arguments (Note that all arguments are ASCII numerical codes, that is, ASCII codes between 48 and 57)	Response to Command (Target-to-Controller)	Query (Code and qualifier)	Response to query (Target-to-Controller)
Config Load	CLD=	1 byte, numerical, 0 to 9	Command only. Forces the Switch to retrieve the Configuration Memory location defined by the argument (0 to 9) and to re-program the Switch with that stored configuration.	CLD= (message OK) CLD? (received OK, but invalid arguments found) CLD* (message OK, but the memory location does not contain configuration info)	N/A	N/A
Config Store	CST=	1 byte, numerical, 0 to 9	Command or Query. The command forces the Switch to store the its current configuration in Configuration Memory location defined by the argument (0 to 9). <b>Example:</b> CST=4 (Store current configuration in location 4) <b>WARNING: Use with caution!</b> If the location already contains data, it will be automatically overwritten. If in doubt, query the location first. The query returns the contents of the location.	CST= (message OK) CST? (received OK, but invalid arguments found) CST# (message OK, but only permitted in Remote mode)	CST?n where n is 0 to 9	Returns the same format as the SGC, with the form: CST=xxx...xxx for a valid config, and CST* where no valid config is found
Date	DAY=	6 bytes, numerical	Command or Query. The date, in the form ddmmyy (international date convention), where: dd = day of the month, between 01 and 31, mm = month of the year, between 01 and 12, and yy = year, between 97 and 96 (1997 to 2000, then 2000 to 2096) <b>Example:</b> DAY=240457 would be April 24, 2057.	DAY= (message OK) DAY? (received OK, but invalid arguments) DAY# (message OK, but only permitted in Remote mode)	DAY?	DAY=ddmmyy (see Description of Arguments)
Equipment ID	N/A	4 bytes, alphanumeric	Query only. Unit returns information concerning the equipment identification. <b>Example:</b> S300	N/A	EID?	EID=xxxx (see Description of Arguments)

Parameter Type	Command (Code and qualifier)	Arguments for Command or Response to Query	Description of Arguments (Note that all arguments are ASCII numerical codes, that is, ASCII codes between 48 and 57)	Response to Command (Target-to-Controller)	Query (Code and qualifier)	Response to query (Target-to-Controller)
Faults and Status	N/A	15 bytes, alphanumeric	Query only. Unit returns the current fault and status codes for the Switch itself, where: r = Redundant Modem: 0 = OK 1 = RMI not present 2 = RM I/O timeout 3 = RM not in remote mode 4 = RM is in a test mode 5 = RM is rejecting MGC configuration string 6 = CDM-Qx: Interface is set for IP – No Coms available 7 = CDM-700: RM is rejecting an interface configuration string Power supply information, values 0 or 1 only. A/a = +5V PSU-A under/over B/b = +5V PSU-B under/over C/c = +12V PSU-A under/over D/d = +12V PSU-B under/over E/e = -12V PSU-A under/over F/f = -12V PSU-B under/over m is TMI: interface mismatch: 0 = no problem, 1-9, A (for pos 10) indicates the position of a TMI interface mismatch i is modem I/O communications: 0 = no problem, 1-9, A (for pos 10) indicates the position of a modem which has been activated but is not responding.	N/A	FLT?	FLT=rAaBbCcDdEeFfmi (see Description of Arguments)
Local/ Remote Status	LRS=	1 byte, value of 0 or 1	Command or Query. Where x indicates the local/remote status of the Switch: 0 = local 1 = remote	LRS= (message OK) LRS? (received OK, but invalid arguments found)	LRS?	LRS=x (see Description of Arguments)
Modem Alarm Mask	MAM=	1 byte, numerical	Command or Query. Where x indicates the Modem alarm mask: 0 = no faults masked 1 = Tx faults masked 2 = Rx faults masked 3 = Both Tx and Rx faults masked	MAM= (message OK) MAM? (received OK, but invalid arguments found) MAM# (message OK, but only permitted in Remote mode)	MAM?	MAM=x (see Description of Arguments)

Parameter Type	Command (Code and qualifier)	Arguments for Command or Response to Query	Description of Arguments (Note that all arguments are ASCII numerical codes, that is, ASCII codes between 48 and 57)	Response to Command (Target-to-Controller)	Query (Code and qualifier)	Response to query (Target-to-Controller)
Modem type	N/A	3 bytes, alphanumeric	Query only. Unit returns information concerning the model of the Redundant Modem attached, where xxx is: 600 601 indicates 600L 570 indicates 570/A 571 indicates 570L/AL Qx0 indicates Qx modem, 70-140MHz Qx1 indicates Qx modem, L band. 700 indicating the CDM-700 modem 710 indicating the CDM-710 modem 5650 indicating the SLM-5650 modem	N/A	MOD?	MOD=xxx (see Description of Arguments)
Number of Unread Stored Events	N/A	2 bytes, numerical	Query only. Switch returns the number of Stored Events, which remain unread. <b>Note:</b> This means unread over the remote control. Viewing the stored events from the front panel of the modem does not affect this value. <b>Example:</b> NUE=98	N/A	NUE?	NUE=xx (see Description of Arguments)
Operating Mode	OPM=	1 byte, numerical	Command or Query. Where x indicates the operating mode: 0 = manual mode 1 = auto mode	OPM= (message OK) OPM? (received OK, but invalid arguments) OPM# (message OK, but only permitted in Remote mode)	OPM?	OPM=x (see Description of Arguments)
Priority mode	PRI=	2 bytes, numerical	Command or Query. Priority mode, where xx is: 00 (priority mode disabled) 01 through 10 – priority link number The Switch will back-up the priority link if: Priority mode is enabled. A fault occurs on the priority link, even if it is already backing-up another (non-priority) link. <b>Note:</b> See Section 7.4.3 for additional information.	PRI= (message OK) PRI? (received OK, but invalid arguments) PRI* (message OK, but not permitted in current mode)	PRI?	PRI=xx (see Description of Arguments)

Parameter Type	Command (Code and qualifier)	Arguments for Command or Response to Query	Description of Arguments (Note that all arguments are ASCII numerical codes, that is, ASCII codes between 48 and 57)	Response to Command (Target-to-Controller)	Query (Code and qualifier)	Response to query (Target-to-Controller)
Retrieve Next 5 unread Stored Events	N/A	80 bytes	<p>Query only.</p> <p>Switch returns the oldest 5 Stored Events, which have not yet been read over the remote control.</p> <p>Reply format:</p> <p>[cr]Sub-body[cr]Sub-body[cr]Sub-body[cr]Sub-body[cr]Sub-body, where Sub-body = KLMddmmyyhhmmss</p> <p>K is the fault/clear indicator, where            F = Fault, C = Clear, I = Info</p> <p>L is the faulting/clearing unit, where the values can be:            1,2,...9 indicating traffic modems 1,2...9,            A=modem 10,            B=Redundant Modem            C=Switch            D=Info</p> <p>M is the fault code, where value depends on faulting unit:            Switch codes are 1 to F, indicating the <b>position</b> (1-15) of the fault within the Switch FLT string.</p> <p>Modem codes are:            1= Unit, 2= Rx traffic, 3= Tx traffic</p> <p>Info codes are:            0= Power off, 1= Power on, 2= Log cleared</p> <p>ddmmyy is the date of the event (international format).            hhmmss is the time of the event.</p> <p>If there are no new events, the unit replies with RNE*.            If fewer than 5 events remain, the last positions are filled with zeroes.</p>	N/A	RNE?	RNE=[cr]KLMddmmyyhhmmss[cr]KLMddmmyyhhmmss[cr]KLMddmmyyhhmmss[cr]KLMddmmyyhhmmss[cr]KLMddmmyyhhmmss (see Description of Arguments)
Restore Holdoff Time	RSH=	2 bytes, numerical	<p>Command or Query.</p> <p>The restore holdoff time is the delay when auto mode prepares to return a modem (previously faulted, now good) back online due to a different Traffic Modem's failure, where:            01-99 = # of seconds after offline Traffic Modem lost its fault before it is put back online so that Redundant Modem can bridge the newly faulted modem.</p>	RSH= (message OK) RSH? (received OK, but invalid arguments found) RSH# (message OK, # (message OK, but only permitted in Remote mode)	RSH?	RSH=xx (see Description of Arguments)

Parameter Type	Command (Code and qualifier)	Arguments for Command or Response to Query	Description of Arguments (Note that all arguments are ASCII numerical codes, that is, ASCII codes between 48 and 57)	Response to Command (Target-to-Controller)	Query (Code and qualifier)	Response to query (Target-to-Controller)
Switch Alarm Mask	SAM=	1 byte, numerical	Command or Query. Where <b>x</b> indicates the Switch alarm mask: 0 = no faults masked 1 = PSU-A faults masked 2 = PSU-B faults masked	SAM= (message OK) SAM? (received OK, but invalid arguments found) SAM# (message OK, but only permitted in Remote mode)	SAM?	SAM=x (see Description of Arguments)
SwitchDataTime	SDT=	1 byte, numerical	Command or Query. This command allows the Switch to send commands to all attached modems on a daily basis to set their time and date values to the same as the Switch. This value is also saved in nonvolatile memory to retain setting during a power outage. The factory default setting is SDT=0.  SwitchDataTime, where x where: 0 turns off this feature. 1 enables this feature <b>Example:</b> SDT=1	SDT= (message OK) SDT? (received OK, but invalid arguments) SDT* (message OK, but not permitted in current mode)	SDT?	SDT=xx (see Description of Arguments)
Switch Global Configuration	SGC=	29 bytes, numerical	Command or Query. Global configuration of the Switch, in the form: OaaaaaaaaaBNNbrrMSAPsssssss, where: O = Operating Mode – same as OPM (1 bytes) a = Active Modems – same as ACT (10 bytes) B = Bridge/Backup State – same as BBU (1 byte) N = Selected TM Number - same as BBU (2 bytes) b = Backup Holdoff Time – same as BKH (2 byte) r = Restore Holdoff Time – same as RSH (2 byte) M = Modem Alarm Mask – same as MAM (1 byte) S = Switch Alarm Mask – same as SAM (1 byte) A = Audio Alarm Mask – same as AAM (1 bytes) P = Priority mode – same as PRI s = 7 spare bytes	SGC= (message OK) SGC? (received OK, but invalid arguments found) SGC# (message OK, but only permitted in Remote mode)	SGC?	SGC=OaaaaaaaaaBNNbrrMSAPsssssss (see Description of Arguments)
Switch ID	SID=	24 bytes, ASCII	Command or Query. A user-defined Switch ID, which is a fixed length of 24 characters.  Valid characters include: Space ( ) * + - , . / 0-9 and A-Z.	SID= (message OK) SID? (received OK, but invalid arguments found) SID# (message OK, but only permitted in Remote mode)	SID?	SID=xxxxxxxxxxxxxxxxxxxx xxxxxxx (see Description of Arguments)

Parameter Type	Command (Code and qualifier)	Arguments for Command or Response to Query	Description of Arguments (Note that all arguments are ASCII numerical codes, that is, ASCII codes between 48 and 57)	Response to Command (Target-to-Controller)	Query (Code and qualifier)	Response to query (Target-to-Controller)
Serial Number	N/A	9 bytes, numerical	Query only. Unit returns its 9-digit serial number. <b>Example:</b> SNO=176512523	N/A	SNO?	SNO=xxxxxxxx (see Description of Arguments)
Software Revision	N/A	4 bytes, numerical	Query only. Unit returns the value of internal software revision installed in the unit, in the form x.xx <b>Example:</b> SWR=1.03 (Ver 1.03)	N/A	SWR?	SWR=x.xx (see Description of Arguments)
Time	TIM=	6 bytes, numerical	Command or Query. The time from midnight, in the form hhmmss, where hh = hours, between 00 and 23, mm = minutes, between 00 and 59, and ss = seconds, between 00 and 59 <b>Example:</b> TIM=231259 would be 23 hours, 12 minutes and 59 seconds from midnight.	TIM= (message OK) TIM? (received OK, but invalid arguments) TIM# (message OK, but only permitted in Remote mode)	TIM?	TIM=hhmmss (see Description of Arguments)

Parameter Type	Command (Code and qualifier)	Arguments for Command or Response to Query	Description of Arguments (Note that all arguments are ASCII numerical codes, that is, ASCII codes between 48 and 57)	Response to Command (Target-to-Controller)	Query (Code and qualifier)	Response to query (Target-to-Controller)
TMI/RMI types	N/A	11 Bytes	Query only. Where x indicates the TMI type detected in each slot position: 0 = none present 1 = CRS-320 Rev A 2 = CRS-330 3 = CRS-340 Rev A 4 = CRS-340 Rev B 5 = CRS-370 (HSSI) 6 = CRS-320 Rev C 7 = Undefined 8 = CRS-341 9 = CRS-316 A = CRS-336 B = Undefined C = CRS-315 (TMI) D = CRS-325 (TMI) E = CRS-335 (TMI) F = CRS-345 G = CRS-365 Quad E1 for CDM-Qx H = CRS Quad E1 D-sub for CDM-625/A y indicates the RMI detected in slot II 0 = none present 7 = CRS-310 D = CRS-307 E = CRS-306 F = CRS-305 <b>Example:</b> XMI=21000000007	N/A	XMI?	XMI=xxxxxxxxxy (see Description of Arguments)



# Appendix A. ETHERNET NETWORK CONFIGURATIONS

---

## A.1 Overview

For operations requiring Ethernet-based terrestrial data handling, it is important to emphasize the need for you to avoid Ethernet looping connection problems – with or without use of the CRS-300 1:10 Redundancy Switch.

The intent of this appendix is to outline the differing methods for Ethernet-based data handling with the various modems featured throughout this manual. Additionally, this appendix outlines use of the CDM-700 Satellite Modem in redundancy. The CDM-700 provides the added functionality of multiple data type handling simultaneously with Ethernet; i.e., Ethernet & HSSI, Ethernet & G.703, etc.

---

## A.2 Ethernet Routers vs. Switches

Routers and switches allow connection of one or more computers or networked devices to other computers or network devices. Each has two or more connectors, called ports, in which cables connect to other network devices.

An **Ethernet router** determines where to forward IP traffic based upon the destination IP address and the Route table entries in the router. An Ethernet router can be programmed to understand and route the data it is directed to handle; for example, broadband routers include the ability to "hide" computers behind a type of firewall, which involves slightly modifying the packets of network traffic as they traverse the device. All routers include some kind of user interface for configuring how the router will treat traffic: larger routers include the equivalent of a full-blown programming language to describe how they should operate, as well as the ability to communicate with other routers to describe or determine the best way to direct network traffic from 'Point A' to 'Point B'.

An **Ethernet switch** examines the traffic that comes across it, and learns where particular MAC addresses are. An Ethernet switch maintains what is known as a **CAM (Content Addressable Memory)** table, listing the MAC addresses for each switch port. The Ethernet switch uses the CAM table to determine where to forward Ethernet frames. By default, Ethernet switches will update the CAM table automatically; for example, if an Ethernet switch sees traffic from 'Machine A'

coming in on 'Port 2', it now knows that 'Machine A' is connected to that port, and that traffic destined for 'Machine A' needs to only be sent to that port and not any of the others.

---

## A.3 Ethernet Configuration Examples

This section explains the problems with **Ethernet Networking Loops**, and how to properly design applications architecture for handling **Standard traffic** and **Split-path traffic**. *Standard traffic* is defined as Rx and Tx Ethernet traffic using the same port on the same router or switch, whereas *split-path traffic* is Rx and Tx Ethernet traffic using different ports of the same router or switch.

Each application also has CRS-300 Redundancy applications examples, with subsequent sections in this appendix providing examples of applications architecture designed to handle near-to-far end Ethernet network configurations. This includes:

- **Sect. A.3.3 Hub-to-Hub With Standard Traffic Using Routers**
- **Sect. A.3.4 Hub-to-Hub With Standard Traffic Using Switches**
- **Sect. A.3.5 Hub-to-Remotes With Standard Traffic Using Routers or Switches**
- **Sect. A.3.6 Hub-to-Remotes, Split-path Traffic Using Routers (Point-to-Multipoint)**
- **Sect. A.3.7 Hub-to-Remotes, Split-path Traffic using Switches (Point-to-Multipoint)**

### A.3.1 Ethernet Network Overview

When placing modems in a network, there are a number of issues that must be addressed – first and foremost on the list of concerns is whether implementation of the switches in the network will cause a **Networking Loop**. This is problematic because a Networking Loop will cause a **Broadcast Storm**, which shuts down the network and causes harm to devices in that network.

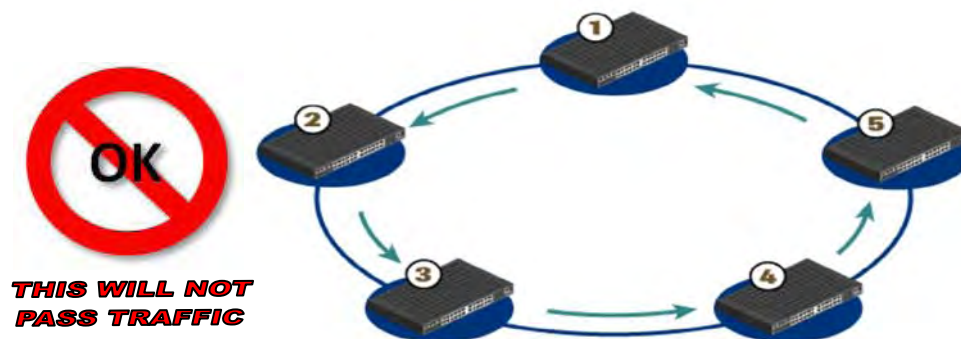


Figure A-1. Networking Loop With Switches

**Figure A-1** illustrates a Networking Loop with switches. The problem with this configuration is that **'Switch 1'** will send out an ARP request looking for a particular MAC, then each subsequent switch passes along that request until **'Switch 1'** receives it again. At this point, two things could happen:

- 1) The switch could continue to forward all requests out all ports, creating more and more traffic on the network until there is no bandwidth available and the switch either reboots or locks up.
- 2) The switch could sense that the ARP request came back to the switch on a different port. The switch could then stop forwarding traffic out the proper port.

Other factors will affect the network: e.g., if the switch is running Spanning Tree Protocol, VLANs, etc.

## A.3.2 Ethernet Redundancy with CRS-300

After the customer has determined the best configuration for near-to-far end Ethernet networks, the CRS-300 1:10 Redundancy Switch may now be added to one or both ends of the link(s). Ethernet redundancy using the CRS-300 can be accomplished using a **wired-thru** or **wired-around** configuration.

---

### A.3.2.1 Wired-thru Connection



This redundancy approach is the recommended and preferred connection method.

The wired-thru Ethernet connection on the CRS-300 is the easiest and simplest choice for Ethernet redundancy. This connection method – the same as used on the standard serial data interface – provides a single connection for the User Data Interface and provides simple form-C relays that route the Ethernet connection from your connection to either the Traffic or Redundant Modem.

---

### A.3.2.2 Wired-around Connection

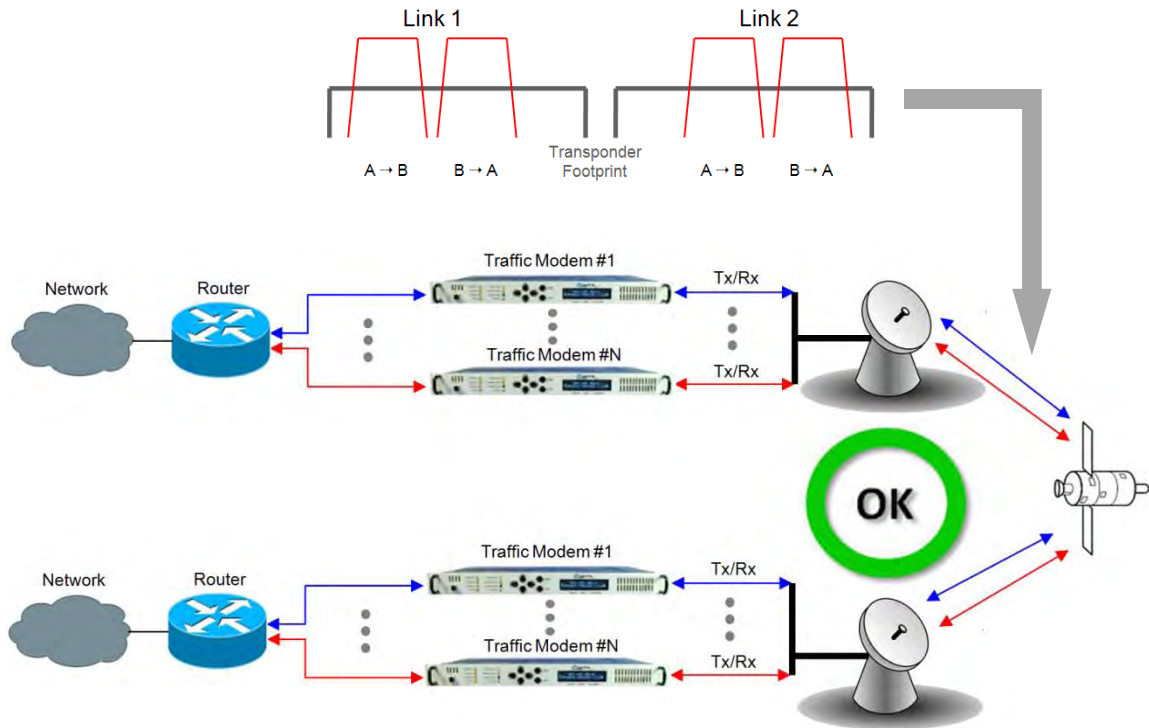


While this redundancy approach is not recommended, it *can* be used after study of the LAN and WAN sides of the IP networks.

Use the wired-around Ethernet connection with the CRS-300 and the CDM-700 modem where both modem data interface slots are needed; e.g., where one slot is HSSI or G.703 and the other slot is GigE. With the Ethernet slot configured for the wired-around method, this gives full redundancy capability to both data slots. However, care must be taken to ensure there are no Ethernet network loops or connection problems – *this method should **only** be used if both modem data slots are used*. In general, the wired-around approach can be used in a hub-to-remotes configuration with standard traffic.

### A.3.4 Hub-to-Hub with Standard Traffic using Routers

Figure A-2 shows two hub-sites connected with standard Ethernet traffic, using routers instead of switches for Ethernet connection. The routers will block the broadcasts coming from the remote network. Therefore, no broadcast storm can be created or the possibility of having a remote MAC on the Hub networks.



**Figure A-2. Hub-to-Hub With Standard Traffic Using Routers**

A wired-thru Ethernet redundancy example is shown in **Figure A-3**. When the CRS-300 1:10 Redundancy Switch “backs up” a faulted Traffic Modem, the physical port on the router does not change, because the Ethernet connection is properly rerouted within the CRS-300 from the Traffic Modem to the Redundant Modem.

A wired-around Ethernet redundancy example is shown for the CDM-700 User in **Figure A-4**. When the CRS-300 1:10 Redundancy Switch backs up a faulted Traffic Modem, the physical port on the router needs to change from the Traffic Modem port to the Redundant Modem port. Because of this, special router configuration is required for successful operation – you may need to consult with the router manufacturer.



**CAUTION – The wired-around redundancy approach is not recommended.**

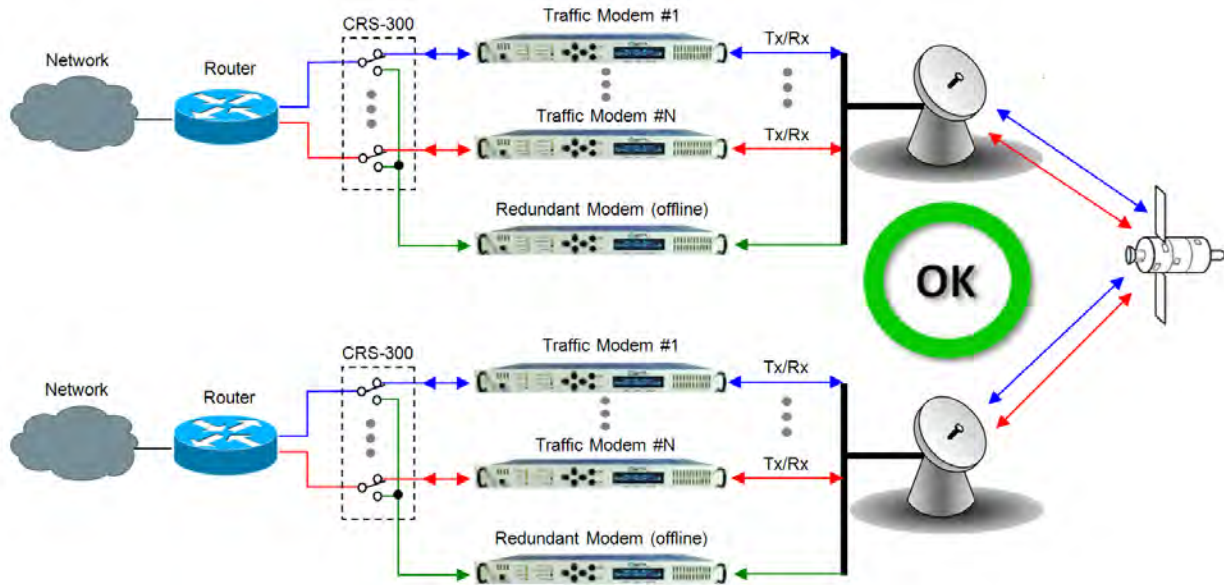


Figure A-3. Wired-thru for Hub-to-Hub With Standard Traffic Using Routers

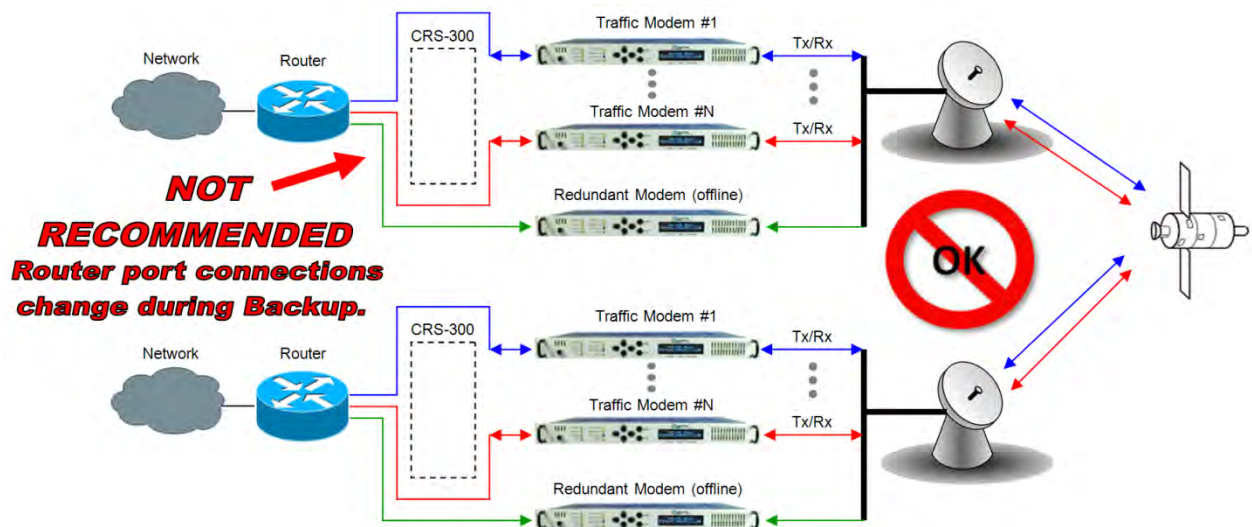


Figure A-4. Wired-around For Hub-to-Hub With Standard Traffic Using Routers

### A.3.5 Hub-to-Hub with Standard Traffic using Switches

When connecting two or more “hub-sites” where there are multi-paths between each site, care must be taken to ensure no network loops occur. **Figure A-5** depicts two hub-sites connected with two or more modems where all the traffic being transmitted and received is on the same LAN/VLAN.

**Figure A-6** shows a simplified version of the Networking Loop. Since there is no router in the network and all the traffic is destined to the same network, routing loops have been created.

As illustrated, two switches have been connected, each with two or more separate connections. This is not how the Ethernet switches were designed to be used, and this configuration will cause a network outage.

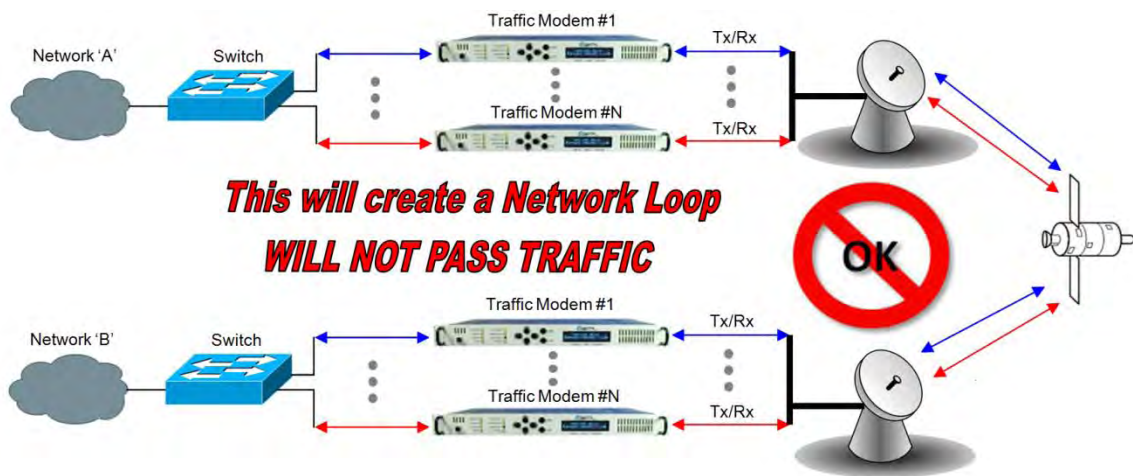


Figure A-5. Networking Loop Example

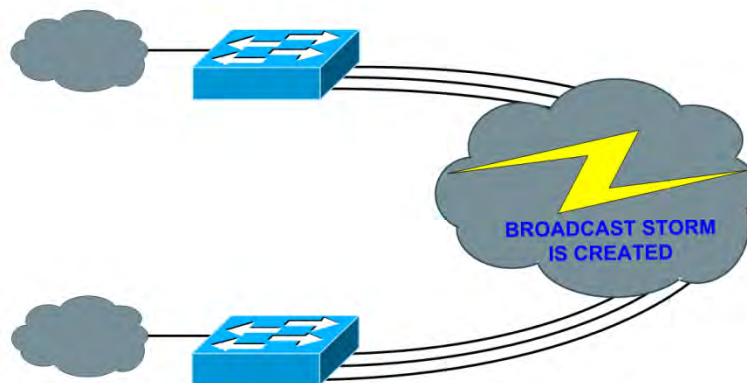
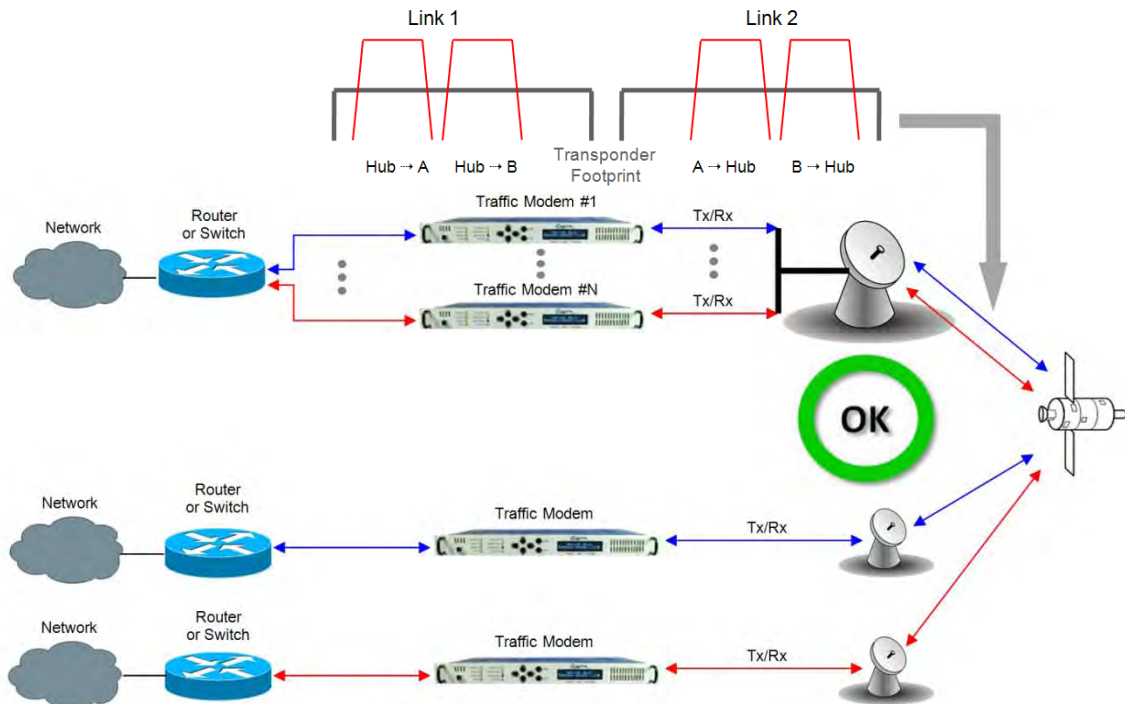


Figure A-6. Networking Loop Example (Simplified)

BLANK PAGE

### A.3.6 Hub-to-Remotes with Standard Traffic using Routers or Switches

Figure A-7 shows hub-to-remotes configuration with standard Ethernet traffic using routers or switches. The routers/switches will block broadcasts coming from the hub and remote networks. Therefore, no broadcast storm can be created or the possibility of having a remote MAC on the Hub networks.

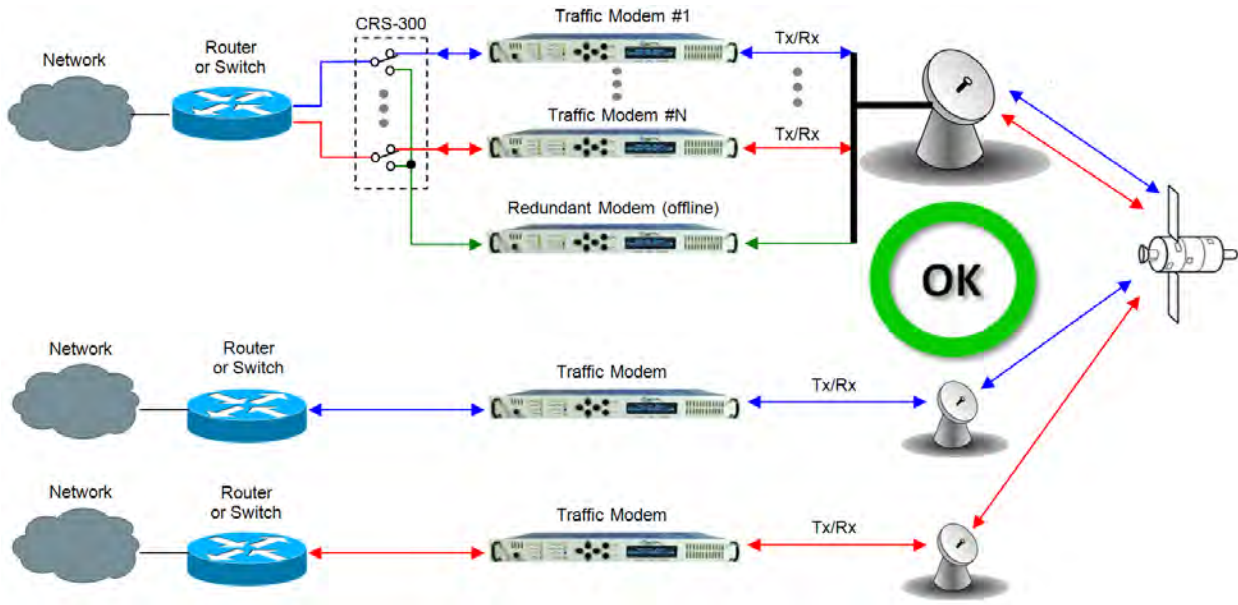


**Figure A-7. Hub-to-Remotes With Standard Traffic Using Routers or Switches**

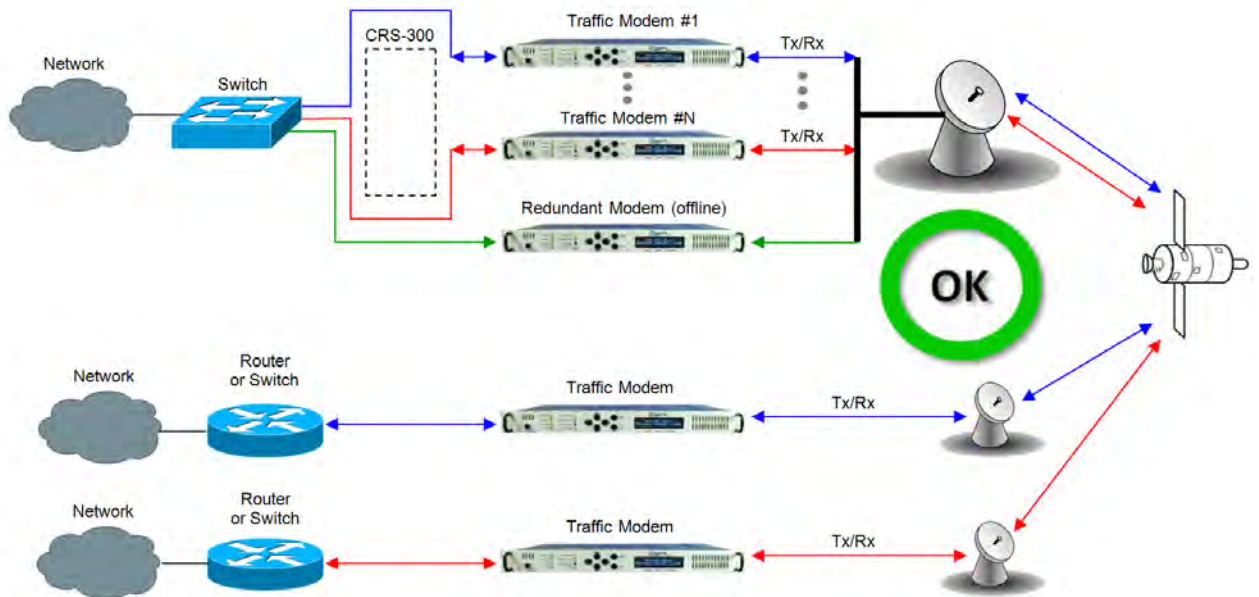
A wired-thru Ethernet redundancy example is shown in Figure A-8. When the CRS-300 1:10 Redundancy Switch backs up a faulted Traffic Modem, the physical port, (on the router) does not change because the Ethernet connection is properly rerouted within the CRS-300 from the Traffic Modem to the Redundant Modem.

A wired-around Ethernet redundancy example for the CDM-700 User is shown Figure A-9. When the CRS-300 1:10 Redundancy Switch backs up a faulted Traffic Modem, the Switch will learn the new MAC address of the redundant unit and traffic will be passed again. This type of architecture will slow down the switching time, because the Switch will need to re-learn the correct port connection.





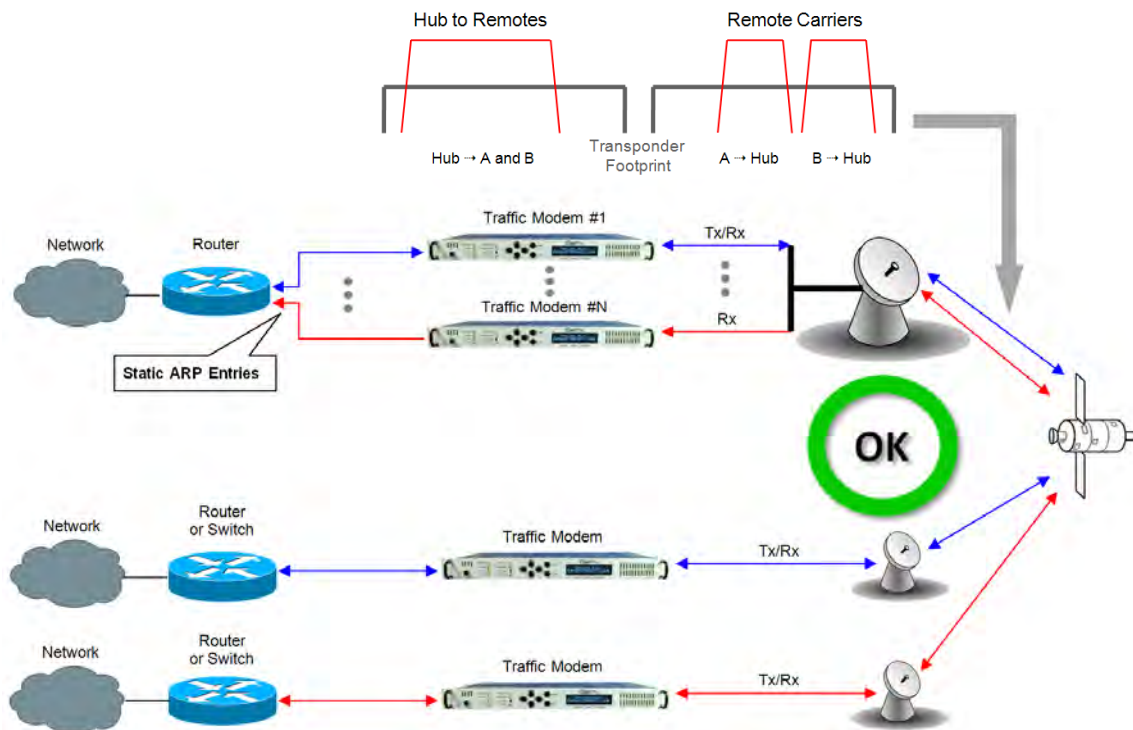
**Figure A-8. Wired-thru for Hub-to-Remotes With Standard Traffic Using Routers or Switches**



**Figure A-9. Wired-around for Hub-to-Remotes With Standard Traffic Using Routers or Switches**

### A.3.7 Hub-to-Remotes, Split-path Traffic using Routers (Point-to-Multipoint)

**Figure A-10** shows hub-to-remotes configuration with standard and split-path Ethernet traffic, using routers. A Static ARP Entry is needed in the switch so that routing of the Tx side of the modems will be on the correct port of the router. For example, the Rx side of the Ethernet connection for 'Traffic Modem #N' comes in the bottom port of the Router, but the Tx Ethernet connection must be connected through the same port as 'Traffic Modem #1', as shown in this figure.



**Figure A-10. Point-to-Multipoint Using Routers**

A wired-thru Ethernet redundancy example is shown in **Figure A-11**. When the CRS-300 1:10 Redundancy Switch backs up a faulted Traffic Modem, the physical port on the router does not change, because the Ethernet connection is properly rerouted within the CRS-300 from the Traffic Modem to the Redundant Modem.

A wired-around Ethernet redundancy example is shown for the CDM-700 User in **Figure A-12**. When the CRS-300 1:10 Redundancy Switch backs up a faulted Traffic Modem, the physical port on the router needs to change from the Traffic Modem port to the Redundant Modem port. Because of this, special router configuration is required for successful operation – you may need to consult with the router manufacturer.



**CAUTION – The wired-around redundancy approach is not recommended.**

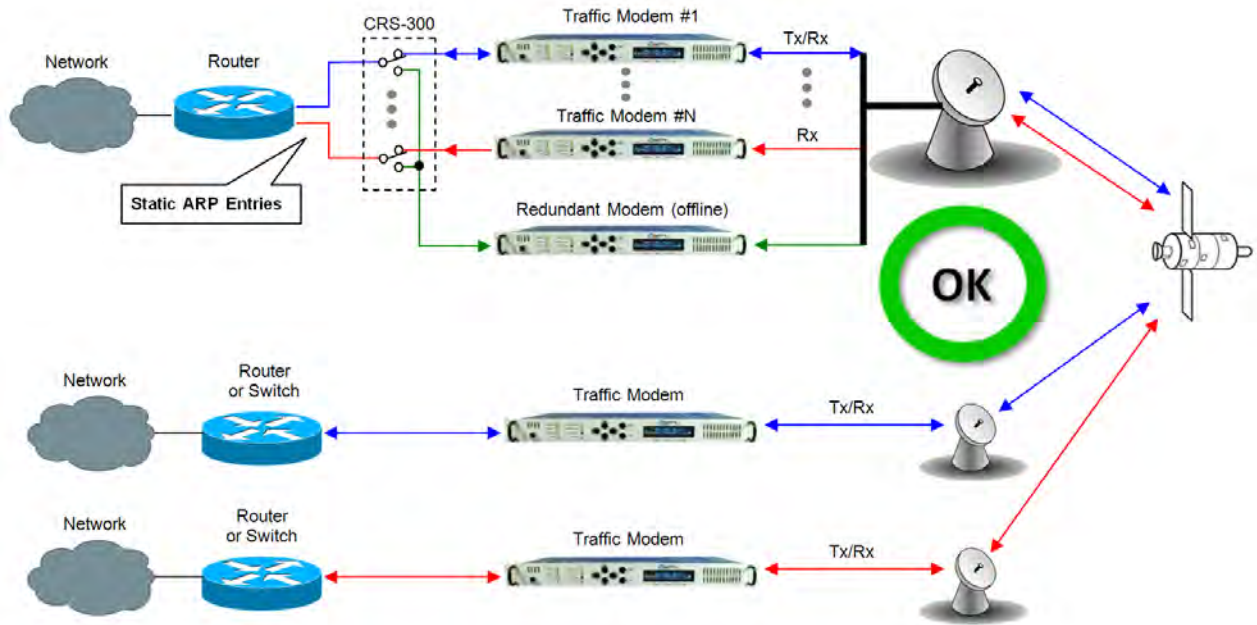


Figure A-11. Wired-thru for Point-to-Multipoint Using Routers

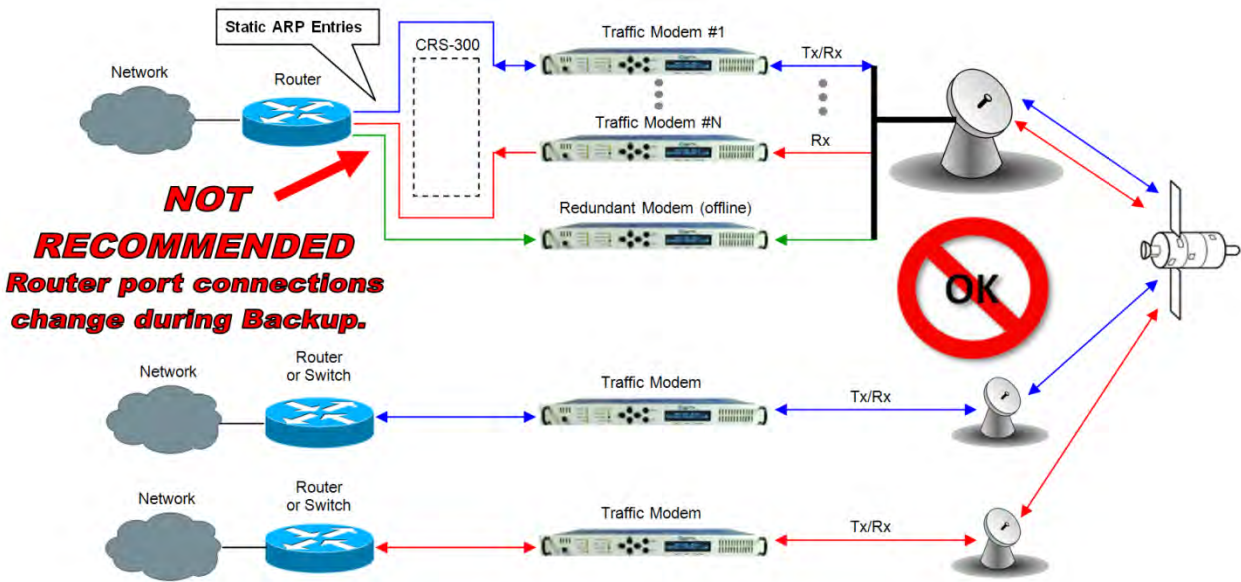
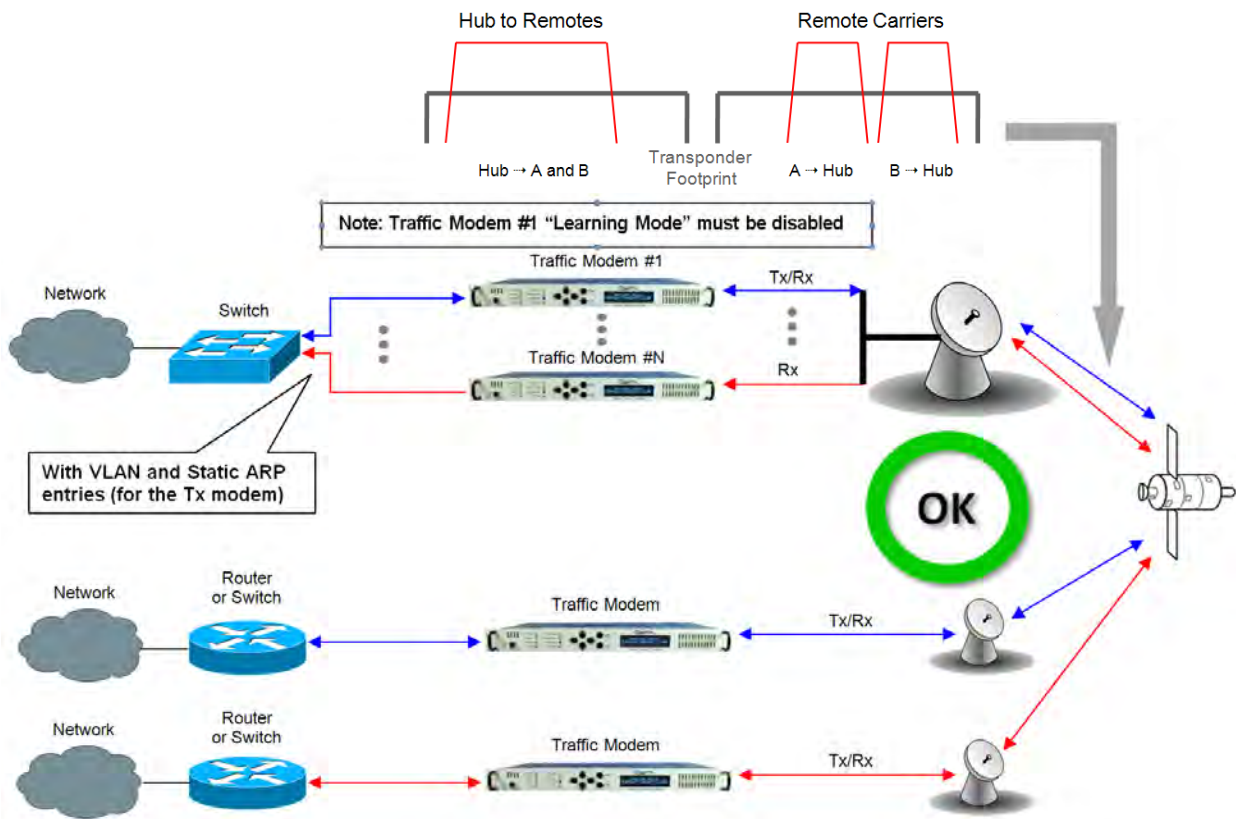


Figure A-12. Wired-around for Point-to-Multipoint Using Routers

### A.3.8 Hub-to-Remotes, Split-path Traffic using Switches (Point-to-Multipoint)

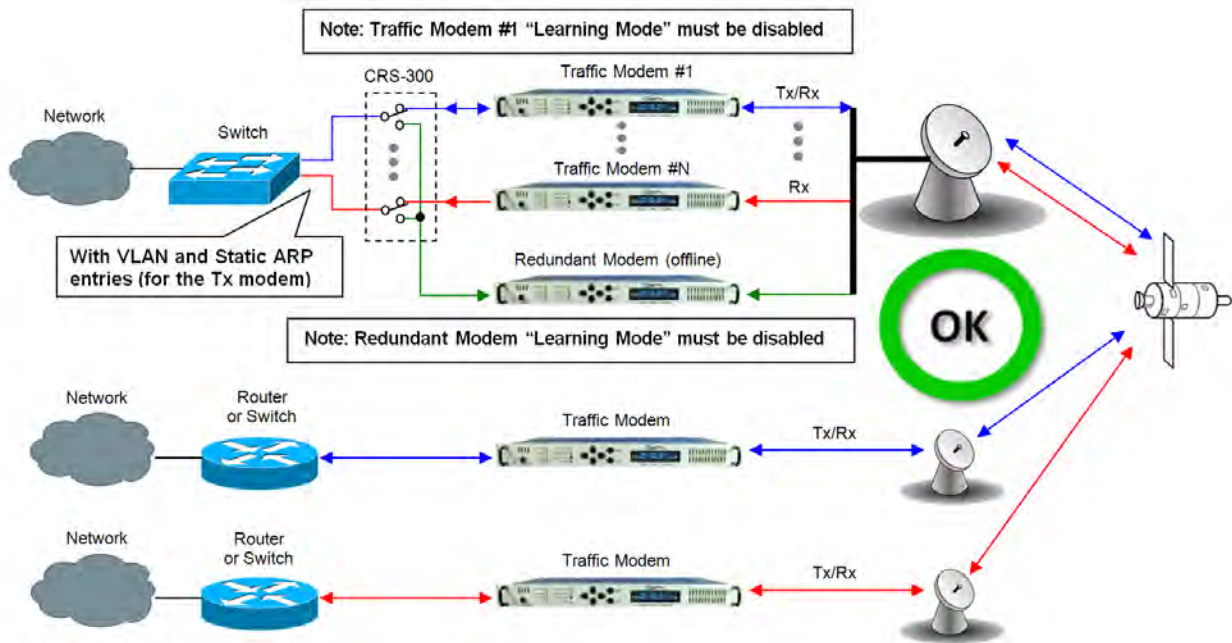
With switches used, the hub and remote are on the same subnet as shown in **Figure A-13**, meaning that broadcasts will be allowed to transverse the network. Learning Mode must be disabled on the Hub Tx/Rx modem, because if a computer on the remote sends a broadcast out to the Hub, the modem learns that MAC is local – when in fact it is not.



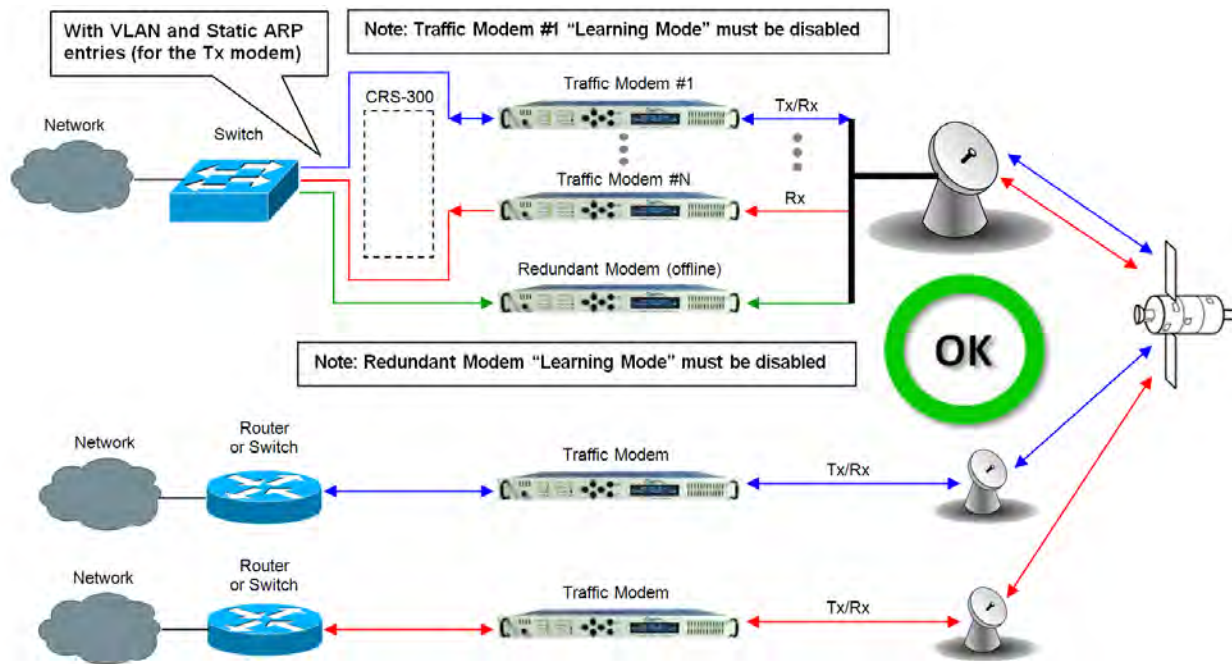
**Figure A-13. Point-to-Multipoint Using Switches**

A wired-thru Ethernet redundancy example is shown in **Figure A-14**. When the CRS-300 1:10 Redundancy Switch backs up a faulted Traffic Modem, the physical port on the Switch does not change, because the Ethernet connection is properly rerouted within the CRS-300 from the Traffic Modem to the Redundant Modem.

A wired-around Ethernet redundancy example is shown for the CDM-700 User in **Figure A-15**. When the CRS-300 1:10 Redundancy Switch backs up a faulted Traffic Modem, the Switch will learn the new MAC address of the redundant unit and traffic will be passed again. This type of architecture will slow down the switching time, because the Switch will need to re-learn the correct port connection.



**Figure A-14. Wired-thru, Hub-to-Remotes, Split-path Traffic Using Switches (Point-to-Multipoint)**



**Figure A-15. Wired-around, Hub-to-Remotes, Split-path Traffic Using Switches (Point-to-Multipoint)**



# Appendix B. CABLE DRAWINGS

---

## B.1 Overview

This appendix contains technical specification drawings for the cables used with the CRS-300 1:10 Redundancy Switch. These cables are divided into three categories – **User/Utility Cables (Sect. B.2)**, **Control Cables (Sect. B.3)**, and **Control/IF/Data Cables (Sect. B.4)**.



The European EMC Directive (EN55022, EN50082-1) requires that you use properly shielded cables for DATA I/O. These cables must be double-shielded from end-to-end, ensuring a continuous ground shield.



The tables in Sections B.3 and B.4 cross-reference the modem-specific cabling figures featured in Chapter 4. CABLES AND CONNECTIONS.

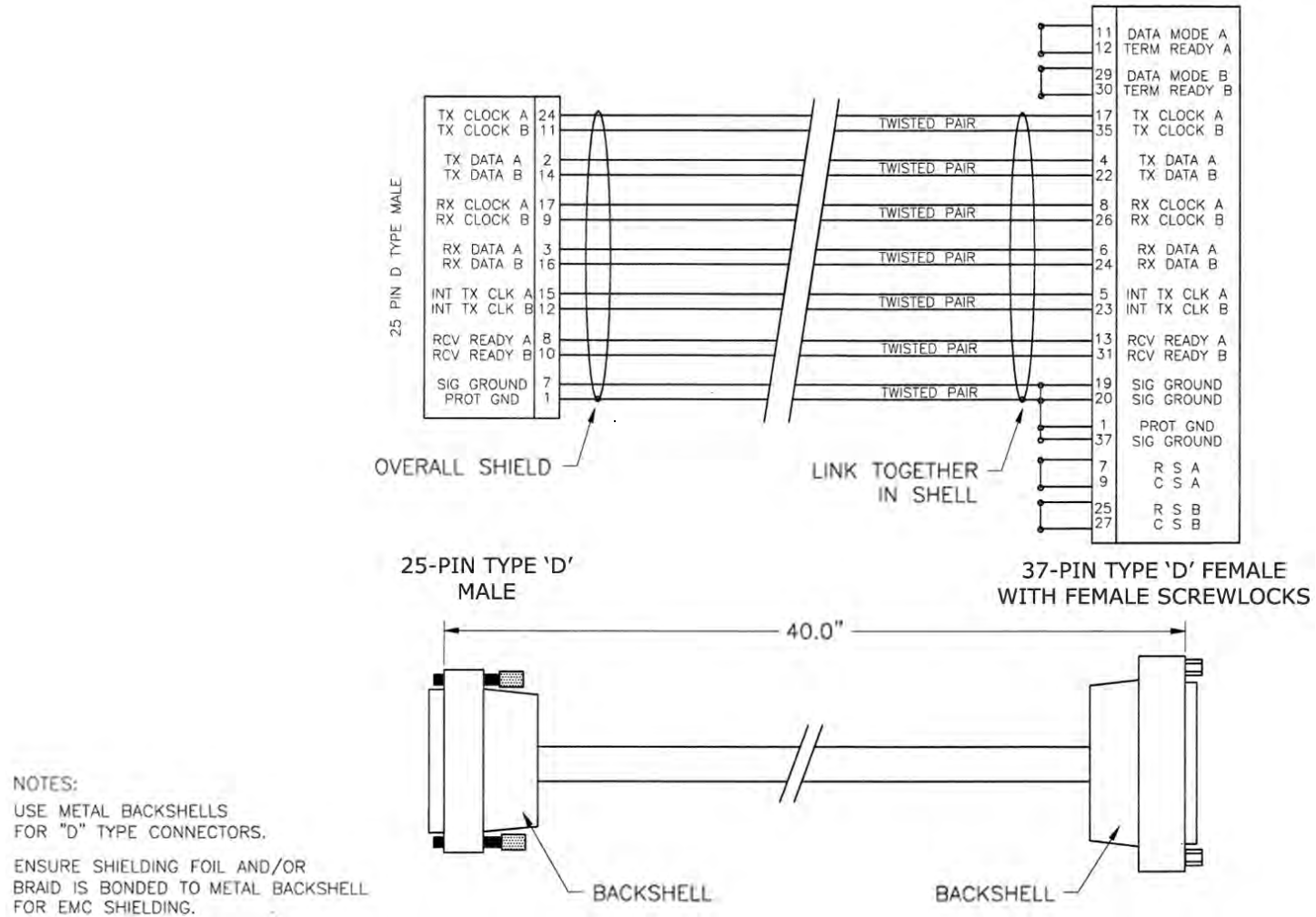
---

## B.2 User / Utility Cables

App. B FIG	CEFD P/N	DESCRIPTION	USED FOR (TRAFFIC TYPE) ...	USED WITH CRS-300 → ...
B-1	N/A	DB-25M → DB-37F	EIA-530 → EIA-422/449 DCE Conversion	User data
B-2	N/A	DB-25M → 34-pin Winchester (Female)	EIA-530 → V.35 DCE Conversion	User data
B-3	N/A	DB-9M → DB-9F	CRS-300 Remote → PC Serial Port	User EIA-232 M&C / Firmware Update

## B.2.1 Switch-to-User, EIA-530-to-EIA-422/-449 Data Conversion Cable (DB-25M→DB-37F)

This cable provides the EIA-530-to-EIA-422/-449 DCE conversion for connections between the Switch and the user data.



**Figure B-1. DCE Conversion Cable – EIA-530 to EIA-422/-449**



## B.2.2 Switch-to-User, EIA-530-to-V.35 Data Conversion Cable (DB-25M→Winchester 34F)

This cable provides the EIA-530 to V.35 DCE conversion for connections between the Switch and the user data.

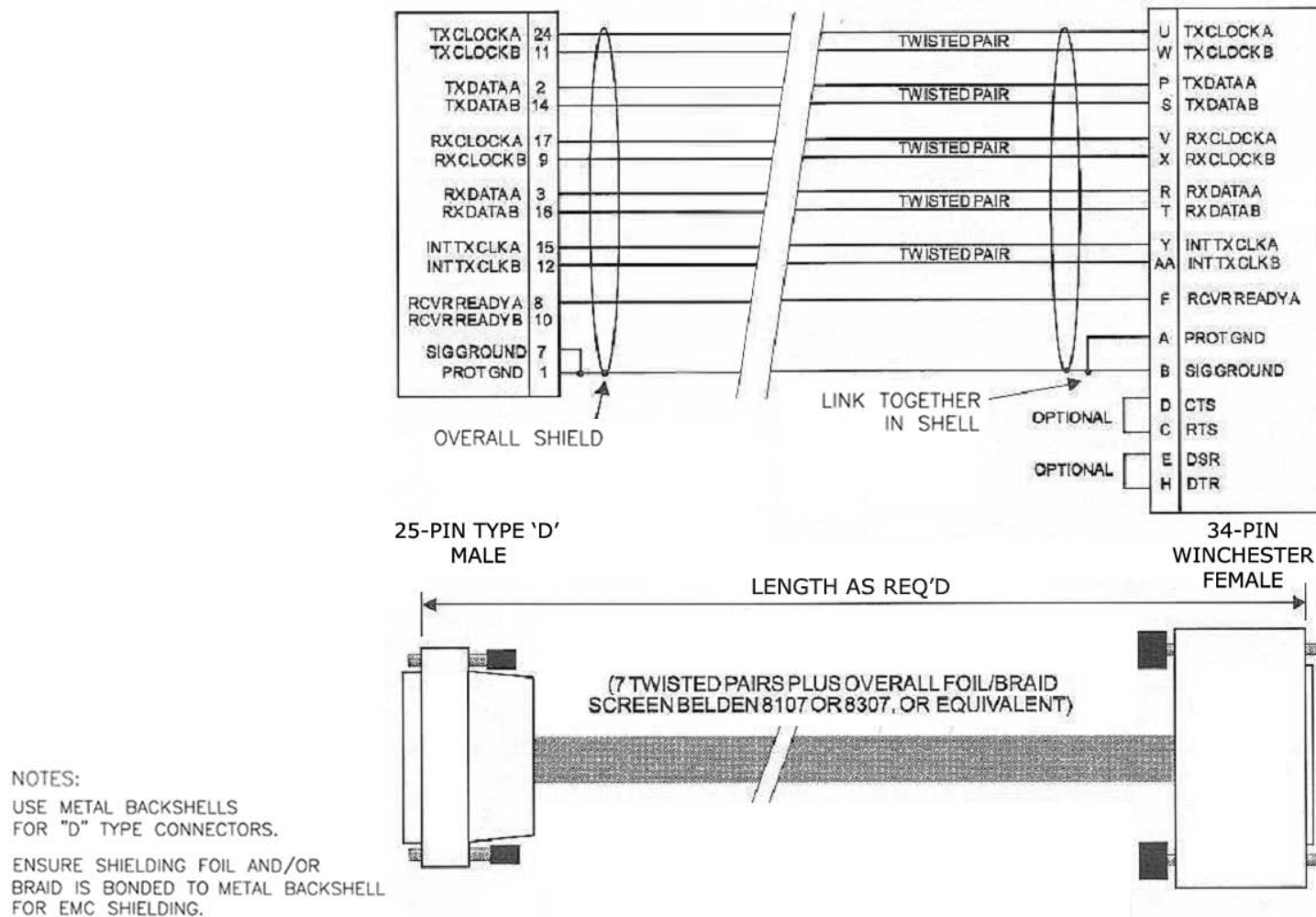


Figure B-2. DCE Conversion Cable – EIA-530-to-V.35

### B.2.3 Switch-to-User, Monitor and Control (M&C) Cable (DB-9F→DB-9F)

You may use this cable for a simple EIA-232 connection between the Switch “Remote Control” connector and a PC serial port. You will need this cable for Switch M&C purposes and to perform your modem’s firmware update procedure.

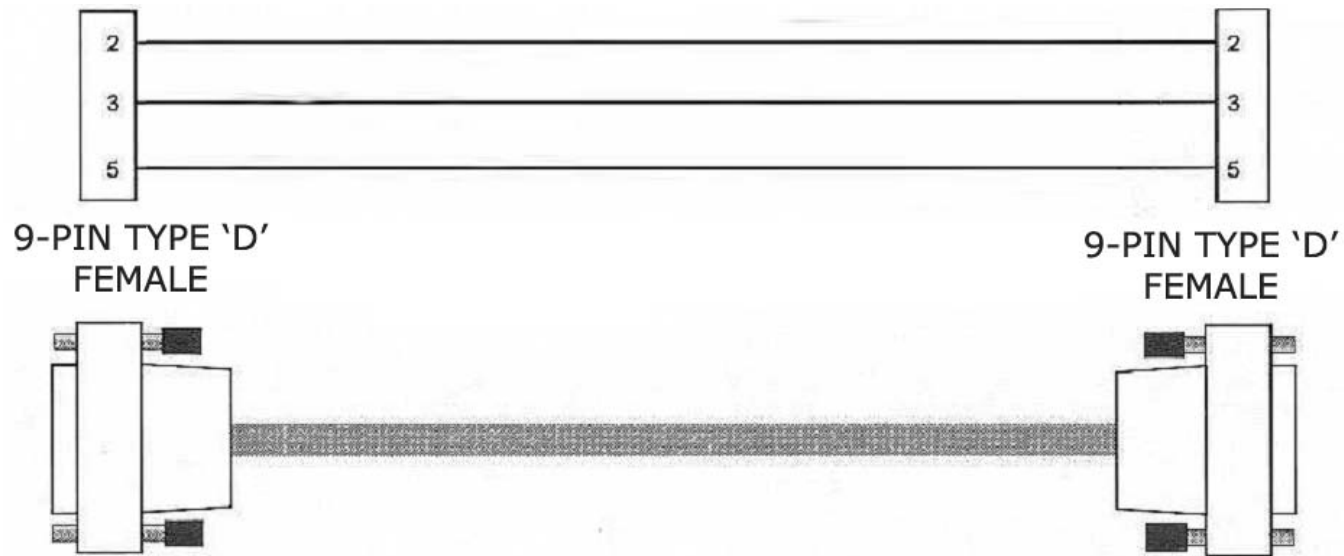


Figure B-3. Switch and Modem M&C Cable

### B.3 Control Cables

App. B FIG	CEFD P/N	DESCRIPTION	USED FOR (TRAFFIC TYPE) ...	USED WITH CRS-300 →...	REF Ch. 4 FIG
B-4	CA-0000069	HD-15M → DB-9M, 6'	Control	CDM-625/A	4-9
					4-10
					4-11
					4-12
B-5	CA/WR12136-1	HD-15M → HD-15M, 4'	Control	SLM-5650/5650A	4-16
					4-17
					4-18
B-6	CA/WR12842-6	HD-15M → DB-9M, HD-15M, 6'	'Y' Control	TMI/RMI → SLM-5650/5650A SLM-5650/5650A AGC, I&Q → User	N/A
B-7	CA/WR11417-1	(15X) DB-9F SHIELDED	EIA-485 Multi-Drop (standard)	CDM-Qx/QxL	4-20
B-8	CA/WR11418-1	Terminal	Terminal		4-20
B-9	CA/WR11419-1	DB-9M → DB-9M, 6"	Null Modem		4-20
B-10	CA/RB11423-1	(15X) DB-9F RIBBON	EIA-485 Multi-Drop (optional)		4-20
B-11	CA/WR12069-1	HD-15M → (2X) DB-15F, 6'	'Y' Control	CDM-Qx/QxL	4-21
					4-22
					4-23
					4-24
					4-25
B-12	CA/WR12361-1	DB-15F → HD-15M, 6'	Control	CDM-710G/710GL	4-26
					4-27
				CDM-710	4-28
					4-29
				CDM-700	4-30
					4-31
					4-32
					4-33
					4-34
					4-35

### B.3.1 Switch-to-Modem, Control Cable for CDM-625/A (HD-15M→DB-9M)

You may use this control cable to connect the Switch to the CDM-625/A Modem.

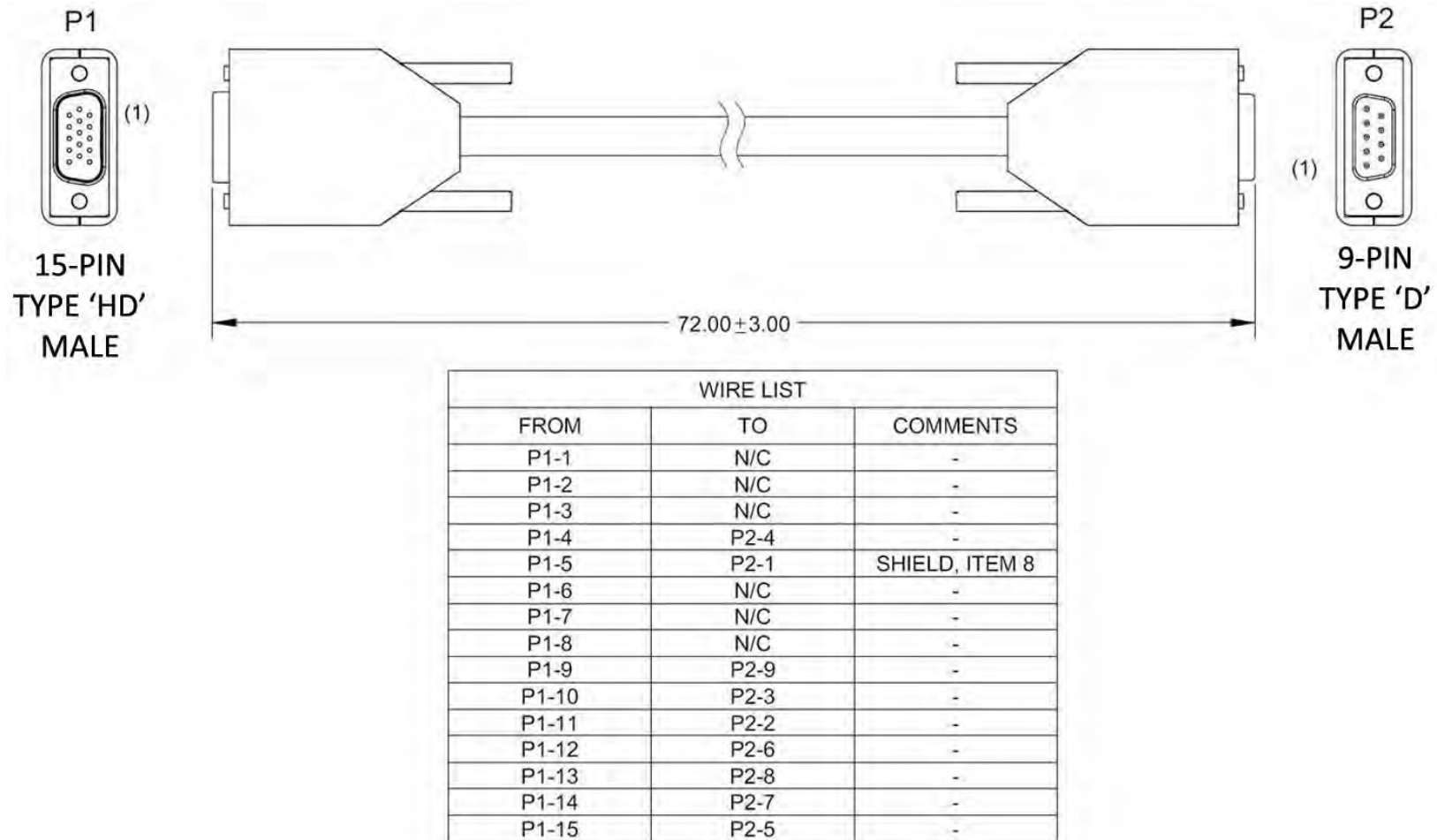


Figure B-4. CDM-625/A Control Cable (CA-000069)

### B.3.2 Switch-to-Modem, Control Cable for SLM-5650/5650A (HD-15M→HD-15M)

You may use this control cable to connect the Switch to the SLM-5650/5650A Modems.

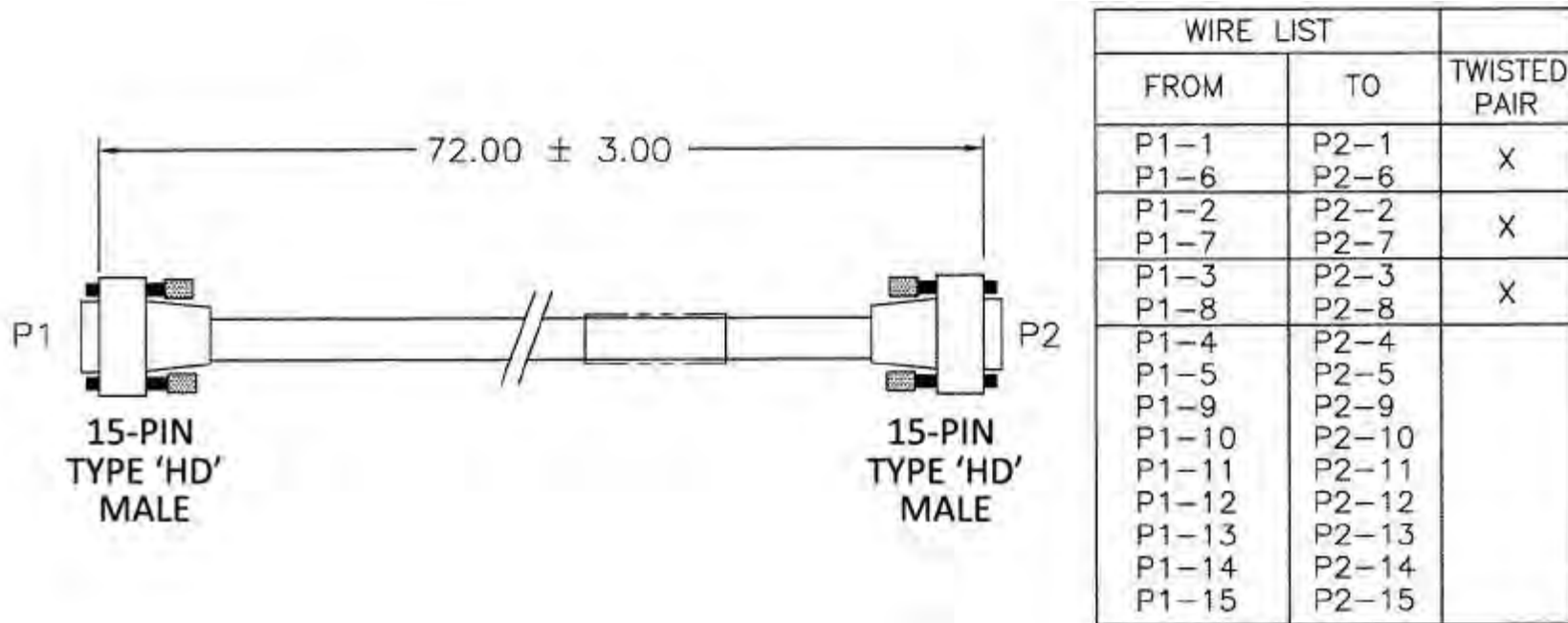


Figure B-5. SLM-5650/5650A Control Cable (CA/WR12136-1)

### B.3.3 Switch-to-Modem, Optional 'Y' Control Cable for SLM-5650/5650A (HD-15M→HD-15M, DB-9F)

You may use this optional 'Y' control cable, purchased separately, in place of the CA/WR12136-1 cable (Figure B-5) to allow User access to the AGC and I&Q outputs of the Modem. It connects the Switch RMI/TMI to the SLM-5650/5650A Modems.

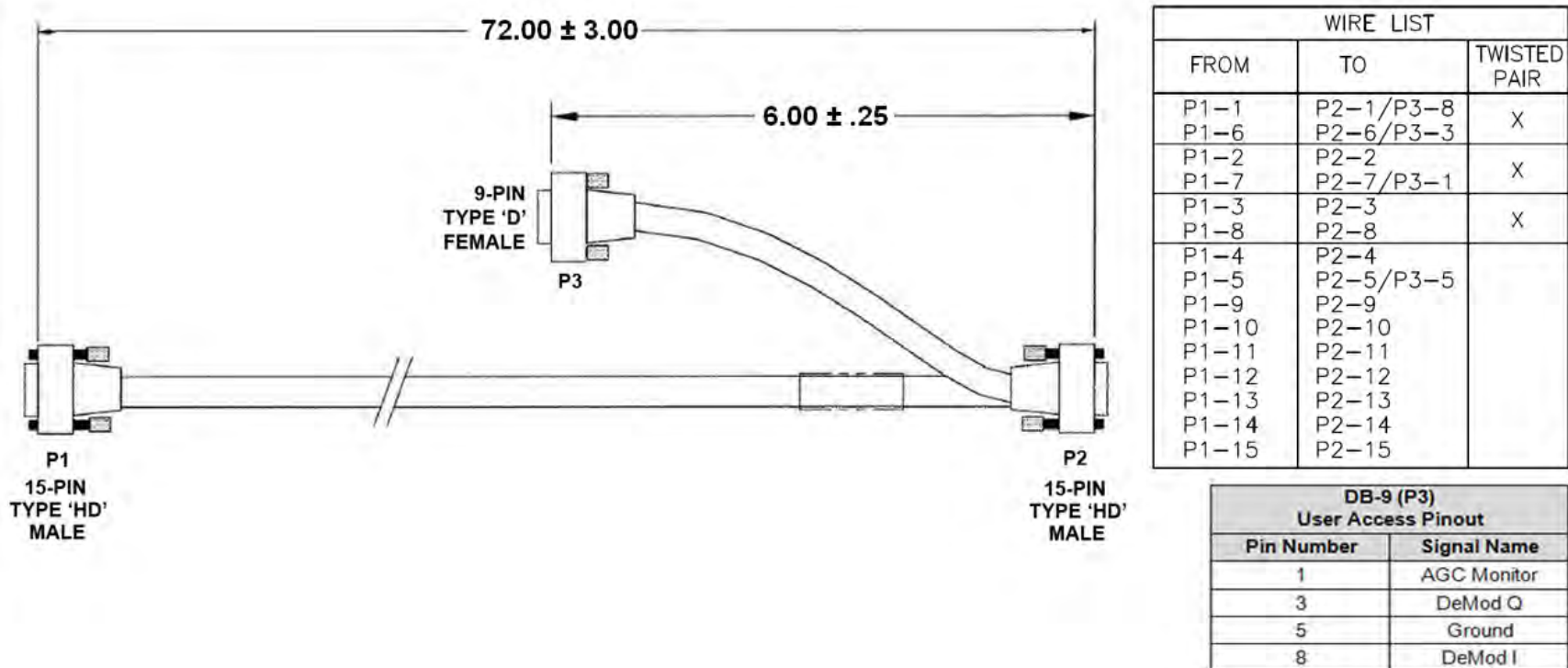


Figure B-6. SLM-5650/5650A 'Y' Control Cable (CA/WR12842-6)

### B.3.4 Switch-to-Modem, Standard EIA-485 Multi-Drop Shielded Cable for CDM-Qx/QxL (15X DB-9F)

You may use this standard Type 'D' 9-pin female Multi-Drop cable to daisy-chain CDM-Qx/QxL Modems for communications.



You may use the optional CA/RB11423-1 EIA-485 Multi-Drop Ribbon Cable (Figure B-10) when Electromagnetic Compatibility (EMC) is not a concern.

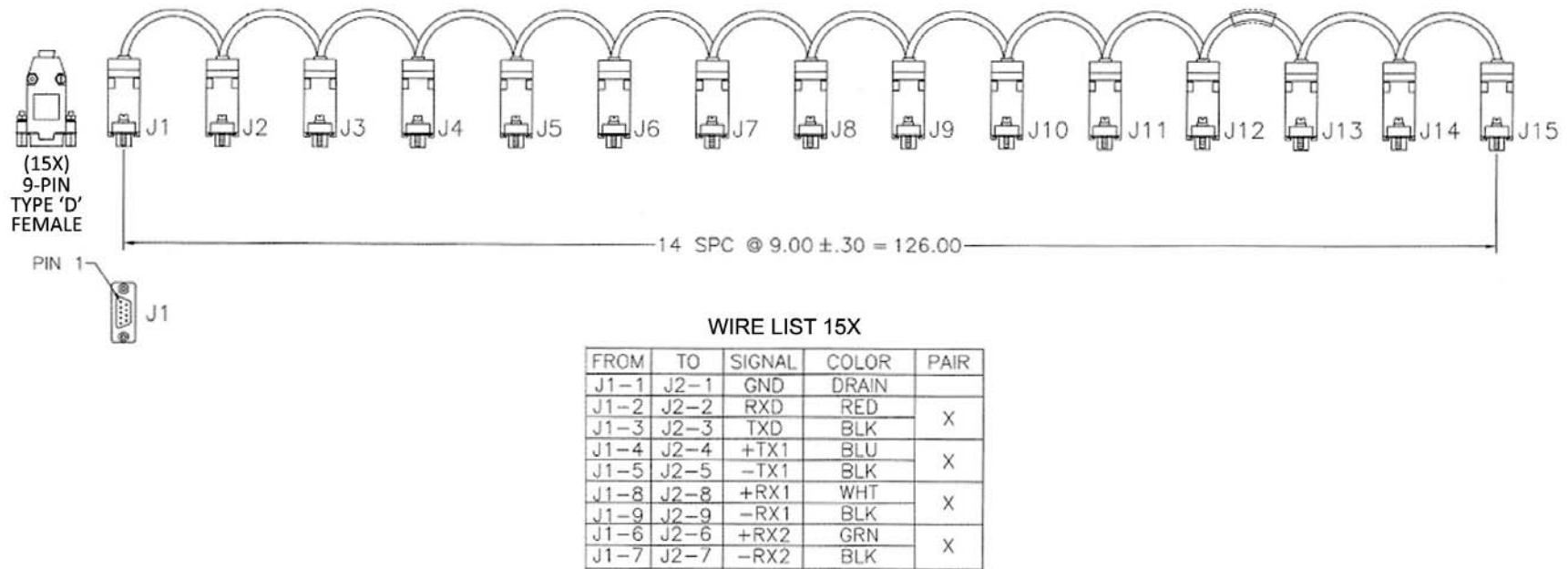
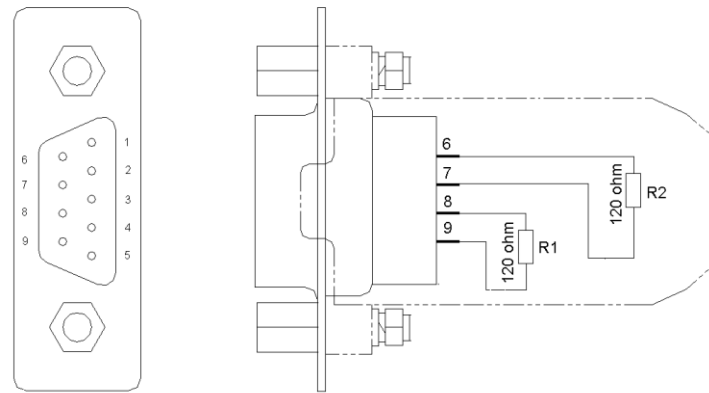


Figure B-7. CDM-Qx/QxL Standard EIA-485 Multi-Drop Shielded Cable (CA/WR11417-1)

### B.3.5 EIA-485 Cable Termination for CDM-Qx/QxL Multi-Drop Cables (DB-9M)

You may use this EIA-485 Cable Termination to terminate the ends of the standard CA/WR11417-1 EIA-485 Multi-Drop Shielded Cable (Figure B-7) or the optional CA/RB11423-1 EIA-485 Multi-Drop Ribbon Cable (Figure B-10).

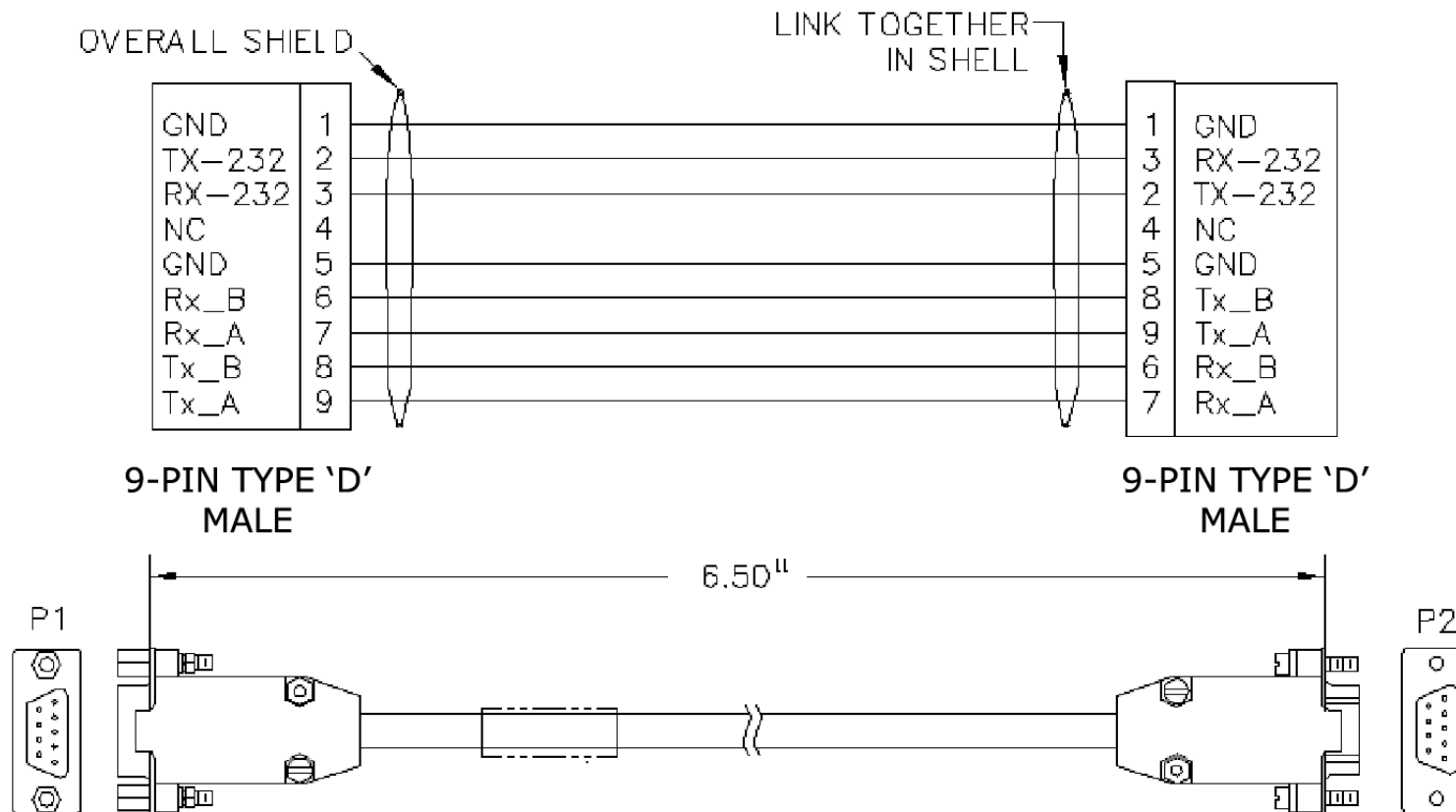


**Figure B-8. CDM-Qx/QxL EIA-485 Cable Termination (CA/WR11418-1)**



### B.3.6 Switch-to-Modem, EIA-485 Null Modem Cable for CDM-Qx/QxL (DB-9M→DB-9M)

You may use this cable as part of the Switch to CDM-Qx/QxL EIA-485 Multi-Drop daisy-chain. Connect one end of this cable to the Switch CRS-230 System Controller “485 Pass-Through” connector, and the other end to one of the DB-9F connectors on either the standard CA/WR11417-1 EIA-485 Multi-Drop Shielded Cable (**Figure B-7**) or the optional CA/RB11423-1 EIA-485 Multi-Drop Ribbon Cable (**Figure B-10**) that interconnects the Modems.



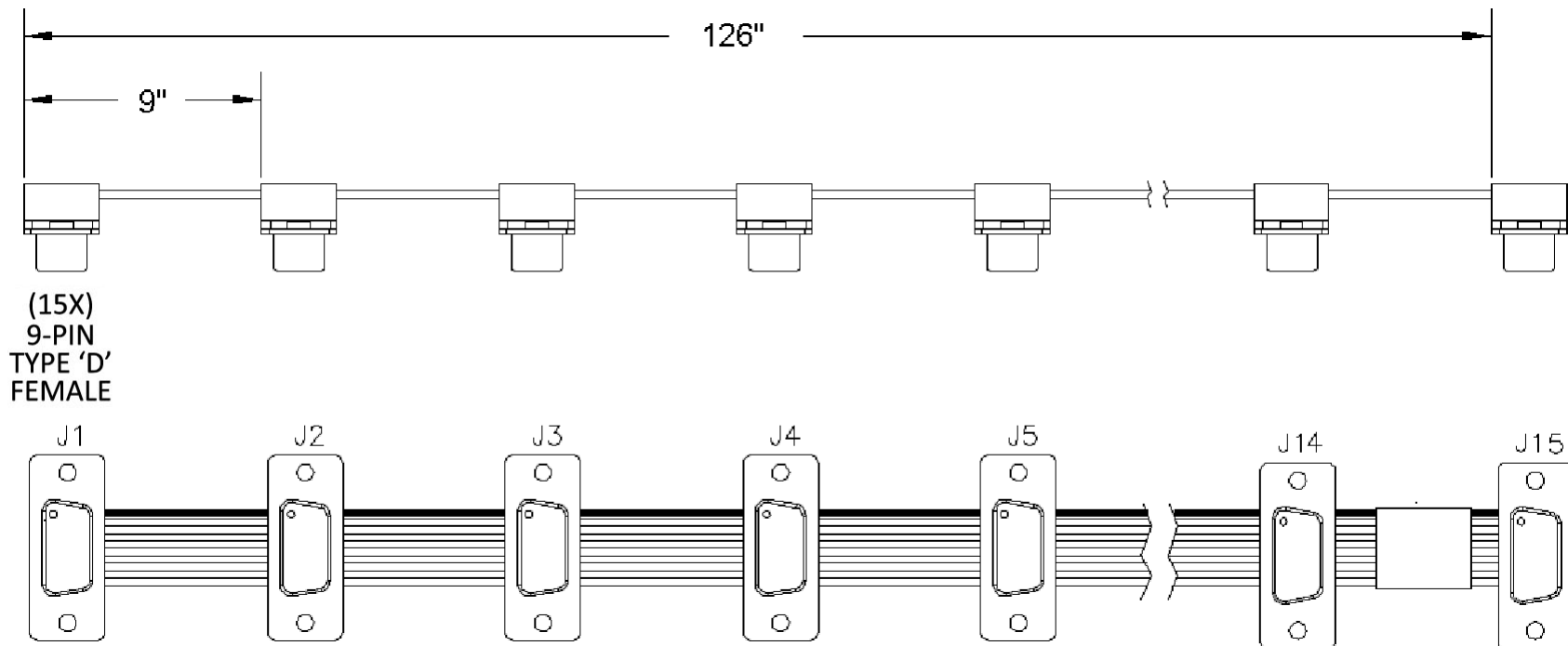
**Figure B-9. CDM-Qx/QxL EIA-485 Null Modem Cable (CA/WR11419-1)**

### B.3.7 Modem-to-Modem, Optional EIA-485 Multi-Drop Ribbon Cable for CDM-Qx/QxL (15X DB-9F)

You may use this optional Type 'D' 9-pin female Multi-Drop ribbon cable to daisy-chain CDM-Qx/QxL Modems for communications when Electromagnetic Compatibility (EMC) is not a concern.



**You must use the standard CA/WR11417-1 EIA-485 Multi-Drop Shielded Cable (Figure B-7) when Electromagnetic Compatibility (EMC) is a concern.**



**Figure B-10. CDM-Qx/QxL Optional EIA-485 Multi-Drop Ribbon Cable (CA/RB11423-1)**

### B.3.8 Switch-to-Modem, 'Y' Control Cable for CDM-Qx/QxL with CnC® (HD-15M→2X DB-15F)

This cable is one of the two types of control cables required for CDM-Qx/QxL Modems. This cable adapts the HD-15 "Fault" connector on the Switch TMI/RMI to the DB-15 "Alarms" connectors on the modem mod and demod modules. These interfaces are capable of CnC® support.

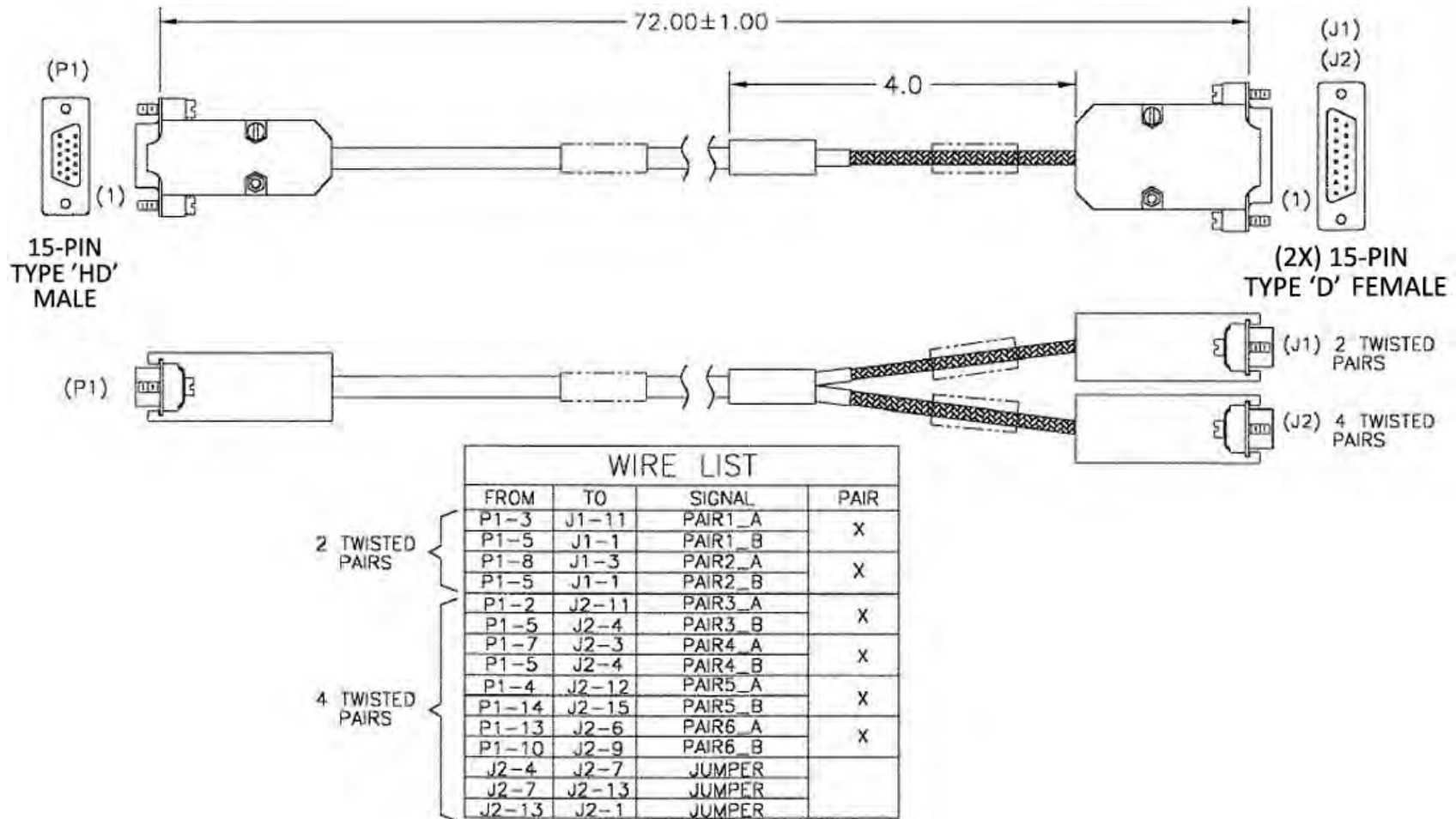


Figure B-11. CDM-Qx/QxL with CnC® 'Y' Control Cable (CA/WR12069-1)

### B.3.9 Switch-to-Modem, Control Cable for CDM-7XX (HD-15M→DB-15F)

You may use this cable to connect the Switch to the CDM-710G/710GL, CDM-710, and CDM-700 Modems.

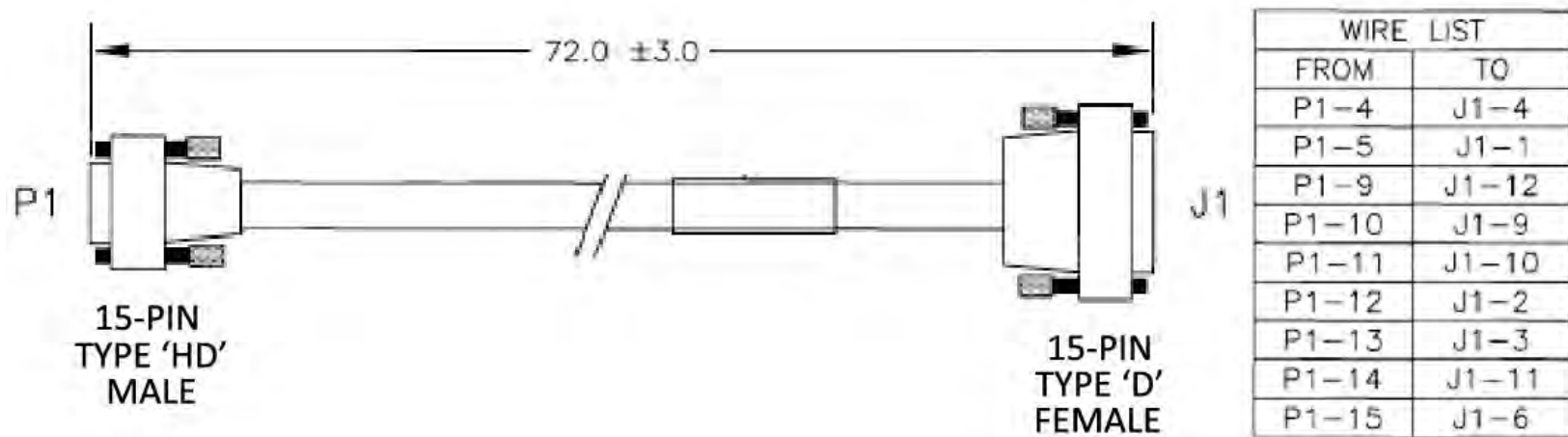


Figure B-12. CDM-7XX Control Cable (CA/WR12361-1)

## B.4 Control / IF / Data Cables & Accessories

App. B FIG	CEFD P/N	DESCRIPTION	USED FOR (TRAFFIC TYPE) ...	USED WITH CRS-300 → ...	REF Ch. 4 FIG
B-13	CA/WR0066	DB-25F → DB-25M, 6'	Control	CRS-280	4-1
				CRS-280L	4-2
				CRS-350	4-3
				CRS-350 → CRS-280	4-4
				CRS-350 → CRS-280L	4-5
			Control/Data	CDM-625/A	4-9
					4-10
					4-11
					4-12
			Control / EIA-422 Data	CDM-570/A, CDM-570L/AL	4-15
			EIA-422 Data, EIA-530/-232	SLM-5650/5650A	4-16
			ESC Data	SLM-5650/5650A → CRS-350	4-19
EIA-422 Data	CDM-Qx/QxL	4-21			
Control / EIA-422 Data	CDM-600/L	4-36			
Control	CDM-600/L → CRS-350	4-37			
B-14	PL/0946-2	50Ω BNC → 50Ω BNC, 8'	IF	Modem → CRS-280	4-7
B-15	PL/0813-8	75Ω BNC → 75Ω BNC, 8'	ASI Data	CDM-625/A	4-9
					4-10
					4-11
					4-12
			Unbal G.703 Data	SLM-5650/5650A	4-17
					CDM-Qx/QxL
			G.703 Data	CDM-710G/710GL	4-26
ASI Data	CDM-710	4-28			
B-16	CA-0000275	(11X) DB-9M, 8.25'	Carrier-in-Carrier® (CnC) Plus	CDM-625/A	4-8
B-17	CA-0000121	HD-50M → RJ-45	10/100 Ethernet	CDM-625/A	4-9
					4-10
					4-11
B-18	CA-0000072	DB-15F → DB-9M, 6'	Bal / Unbal G.703 Data	CDM-625/A	4-9
					4-10

App. B FIG	CEFD P/N	DESCRIPTION	USED FOR (TRAFFIC TYPE) ...	USED WITH CRS-300 → ...	REF Ch. 4 FIG	
B-19	PP/CAT5FF7FTGY	RJ-48 → RJ-48, 7'	10/100 Ethernet	CDM-625/A	4-9	
					4-10	
					4-11	
			Gigabit Ethernet	SLM-5650/5650A	4-16	
				Quad E1 Data	CDM-Qx/QxL	4-25
				Gigabit Ethernet	CDM-710G/710GL	4-27
					CDM-710	4-28
					CDM-700	4-32
						4-33
						4-34
4-35						
B-20	CA/WR9189-6	HD-50M → HD-50M, 6'	HSSI Data	CDM-625/A	4-9	
				SLM-5650/5650A	4-10	
				CDM-Qx/QxL	4-16	
				CDM-710G/710GL	4-24	
				CDM-710	4-27	
				CDM-700	4-29	
				CDM-700	4-31	
4-34						
B-21	CA-0000073	DB-15F → (2X) DB-9M, 6'	Quad E1 Data	CDM-625/A	4-11	
					4-12	
B-22	CA-0000136	DB-9M → DB-9F	Quad E1 Data	CDM-625/A	4-11	
					4-12	
B-23	CA-0000163	DB-9M → (2X) DB-15F	Quad E1 Data	CDM-625/A	N/A	
B-24	CA-0000164	DB-9M → (2X) RJ-48	Quad E1 Data	CDM-625/A	N/A	
B-25	CA-0000074	DB-44M, DB-9M → DB-9M, DB-15M, DB-25F	Overhead Data	CDM-625/A → CRS-350	4-13	
B-26	CA/WR9038-6	DB-15F → DB-15M, 6'	Bal G.703 Data	SLM-5650/5650A	4-17	
				CDM-Qx/QxL	4-22	
				CDM-600/L	4-36	
			IDR Data	CDM-600/L → CRS-350	4-37	
B-27	CA/WR11999-6	DB15F → DB-15M, 6'	Bal G.703 Data	CDM-570/A, CDM-570L/AL	4-15	
B-28	CN-0000268	DB-15M → RJ-48	G.703 T1/E1 Data	CDM-570/A, CDM-570L/AL, CDM-600/L	N/A	
B-29	CA/WR13018	DB-15F → (4X) RJ-48, 6'	Quad E1 Data	CDM-Qx/QxL	4-25	

App. B FIG	CEFD P/N	DESCRIPTION	USED FOR (TRAFFIC TYPE) ...	USED WITH CRS-300 → ...	REF Ch. 4 FIG
B-30	CA/RF12278-1	DB-9F → (8X) BNC, 6'	G.703 Data	CDM-700	4-30
					4-31
					4-33
					4-35
B-31	CA/RF12279-1	DB-15F → (8X) BNC, 6'	G.703 Data	CDM-700	4-30
					4-31
					4-33
					4-35
B-32	CA/WR9932-1	DB-9F → DB-9M, 6'	Audio Data	CDM-600/L → CRS-350	4-37

### B.4.1 Switch-to-Modem / Switch-to-User, EIA-232/422, EIA-530 Control and Data Cable (DB-25M→DB-25F)

You may use this Type 'D' 25-pin cable for EIA-232/422, EIA-530 data connections between the Switch and Modem or between the Switch and the user data.

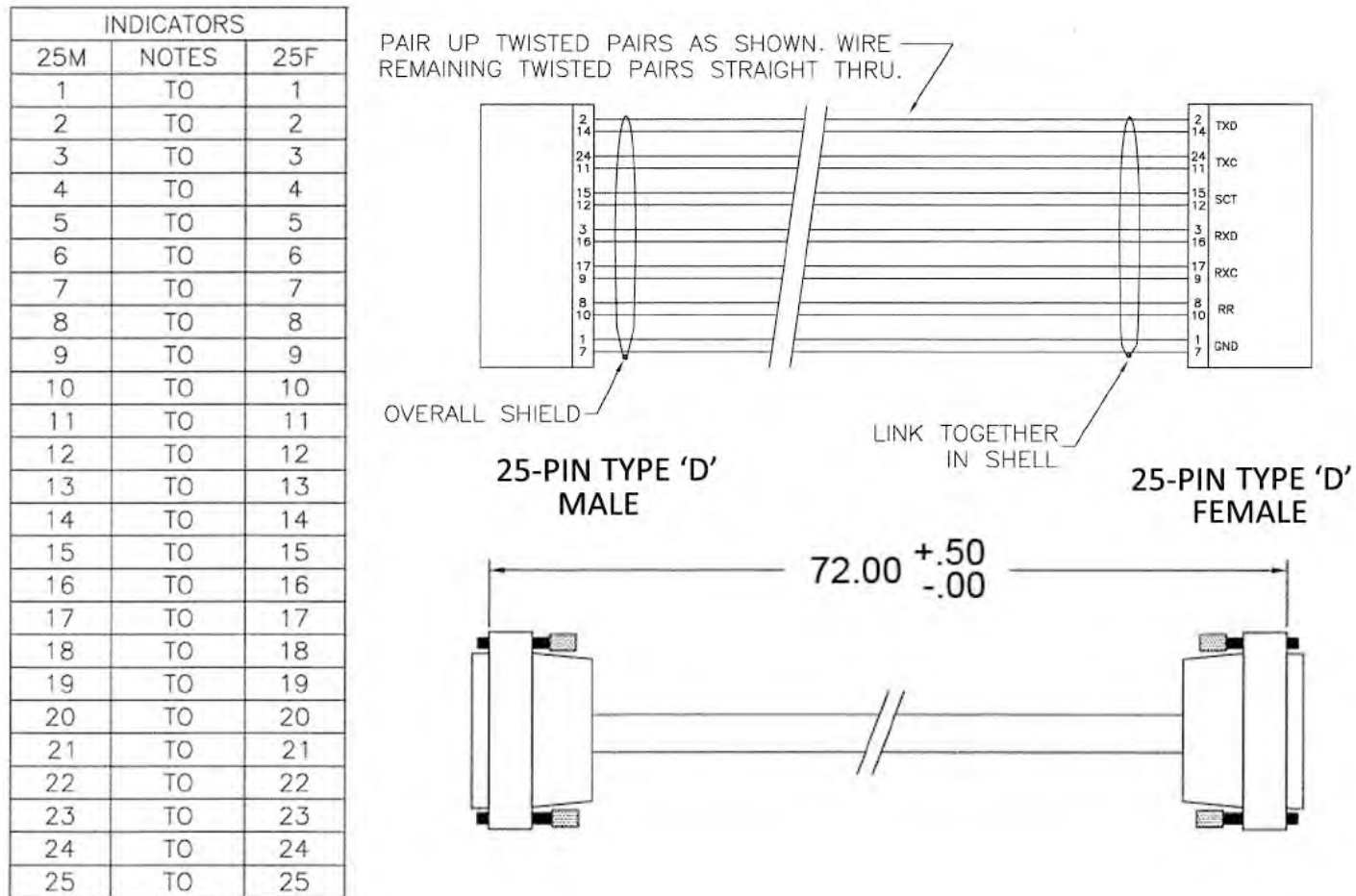
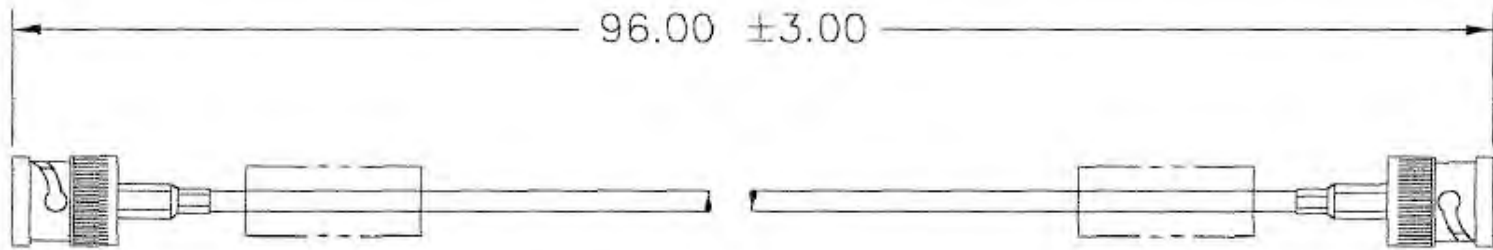


Figure B-13. EIA-232/422, EIA-530 Control and Data Cable (CAWR0066)



## B.4.2 Switch-to-Modem / Modem-to-User, IF Cable (BNC 50Ω Male)

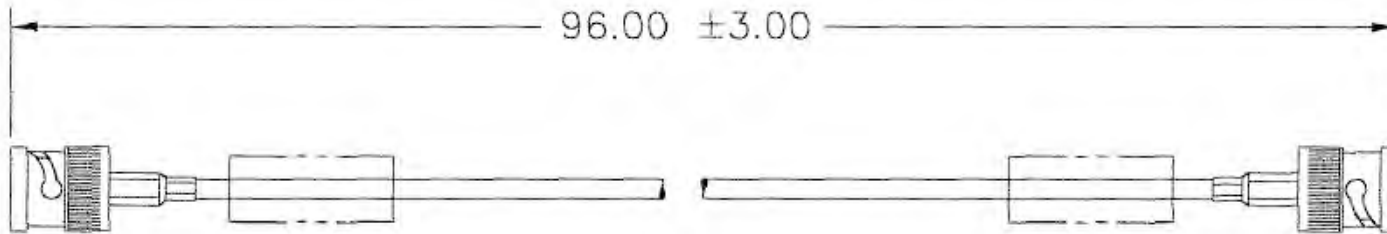
You may use this 50Ω BNC cable used to connect the CRS-280 (70/140 MHz) IF Switch to the Modem.



**Figure B-14. IF Cable, BNC 50Ω for CRS-280 (70/140 MHz) IF Switch (PL/0946-2)**

### B.4.3 Switch-to-Modem, ASI / Balanced G.703 / IF Cable (BNC 75Ω Male)

You may use this 75Ω BNC cable for ASI and Balanced G.703 data connections between the Switch and Modem. You may also use this cable to connect the CRS-280 (70/140 MHz) IF Switch to the Modem.



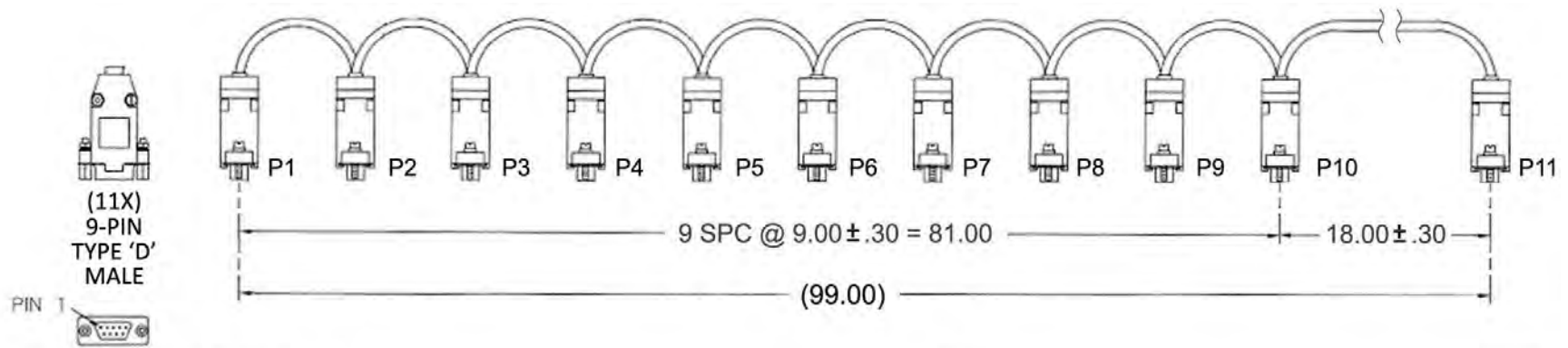
**Figure B-15. ASI / Balanced G.703 / IF Cable, BNC 75Ω (PL/0813-8)**

### B.4.4 Modem-to-Modem, Multi-Drop CnC® Plus Shielded Data Cable for CDM-625/A (11X DB-9M)

You may use this Type 'D' 9-pin Multi-Drop cable to interconnect redundancy-enabled CnC® CDM-625/A Modems.



**This cable bypasses the CRS-300 1:10 Redundancy Switch.**



RESISTOR JUMPER WIRING		
FROM	TO	JUMPER
P1-2	P1-6	ITEM 7 (SEE BOM, CEFD DWG NOTE 6)
P1-3	P1-7	
P1-4	P1-8	
P1-5	P1-9	
P11-2	P11-6	
P11-3	P11-7	
P11-4	P11-8	
P11-5	P11-9	

WIRE LIST													
FROM	TO	TO	TO	TO	TO	TO	TO	TO	TO	TO	TO	COLOR	PAIR
P1-2	P2-2	P3-2	P4-2	P5-2	P6-2	P7-2	P8-2	P9-2	P10-2	P11-2		BLU	X
P1-6	P2-6	P3-6	P4-6	P5-6	P6-6	P7-6	P8-6	P9-6	P10-6	P11-6		BLK	
P1-3	P2-3	P3-3	P4-3	P5-3	P6-3	P7-3	P8-3	P9-3	P10-3	P11-3		RED	X
P1-7	P2-7	P3-7	P4-7	P5-7	P6-7	P7-7	P8-7	P9-7	P10-7	P11-7		BLK	
P1-4	P2-4	P3-4	P4-4	P5-4	P6-4	P7-4	P8-4	P9-4	P10-4	P11-4		GRN	X
P1-8	P2-8	P3-8	P4-8	P5-8	P6-8	P7-8	P8-8	P9-8	P10-8	P11-8		BLK	
P1-5	P2-5	P3-5	P4-5	P5-5	P6-5	P7-5	P8-5	P9-5	P10-5	P11-5		WHT	X
P1-9	P2-9	P3-9	P4-9	P5-9	P6-9	P7-9	P8-9	P9-9	P10-9	P11-9		BLK	

**Figure B-16. Multi-Drop CnC® Plus Shielded Data Cable for CDM-625/A (CA-0000275)**

### B.4.5 Modem-to-User, Ethernet Data Cable for CDM-625/A (RJ-45M→HD-50M)

You may use this Ethernet Data cable to connect the Switch CRS-310 RMI to the CDM-625/A.

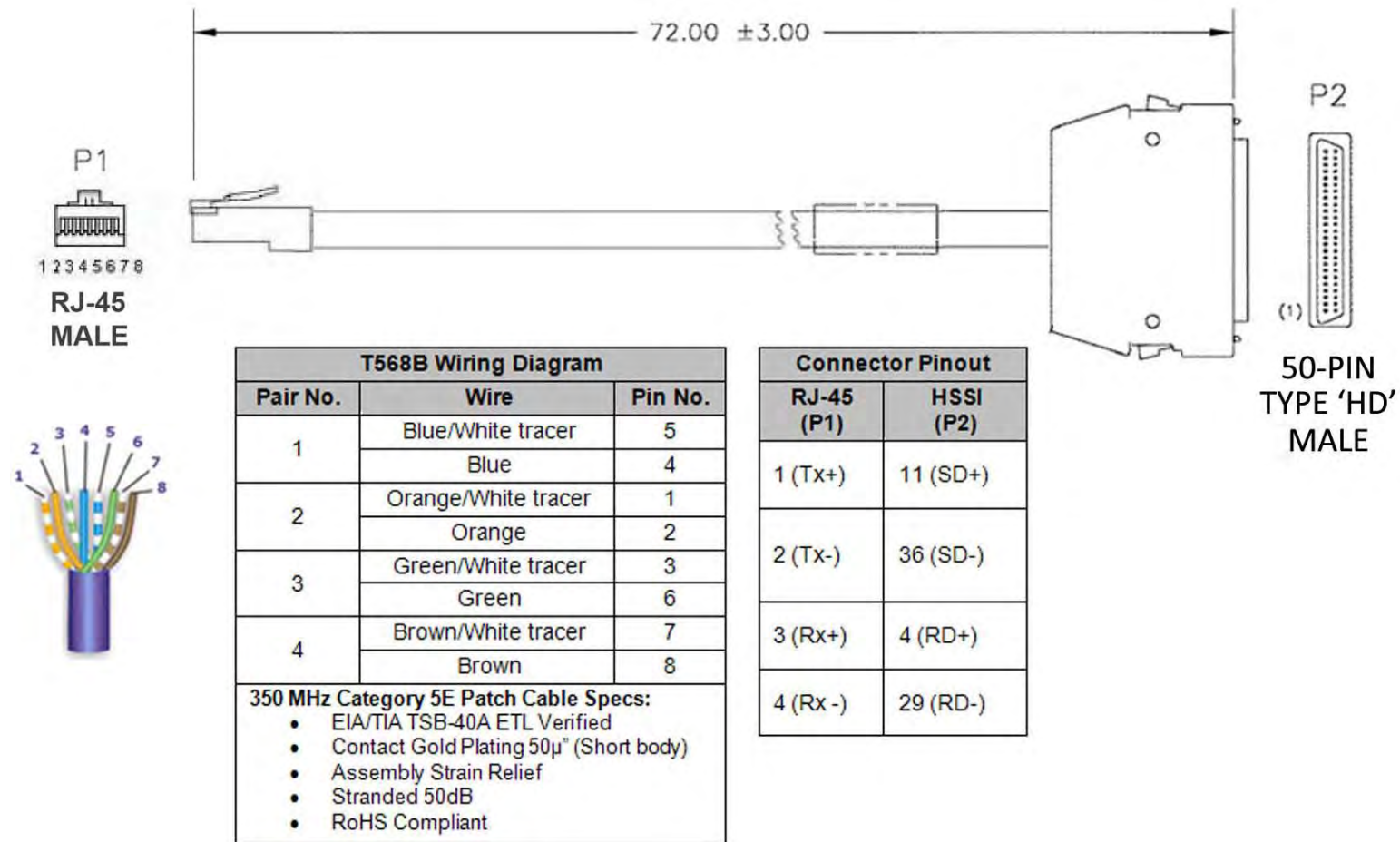
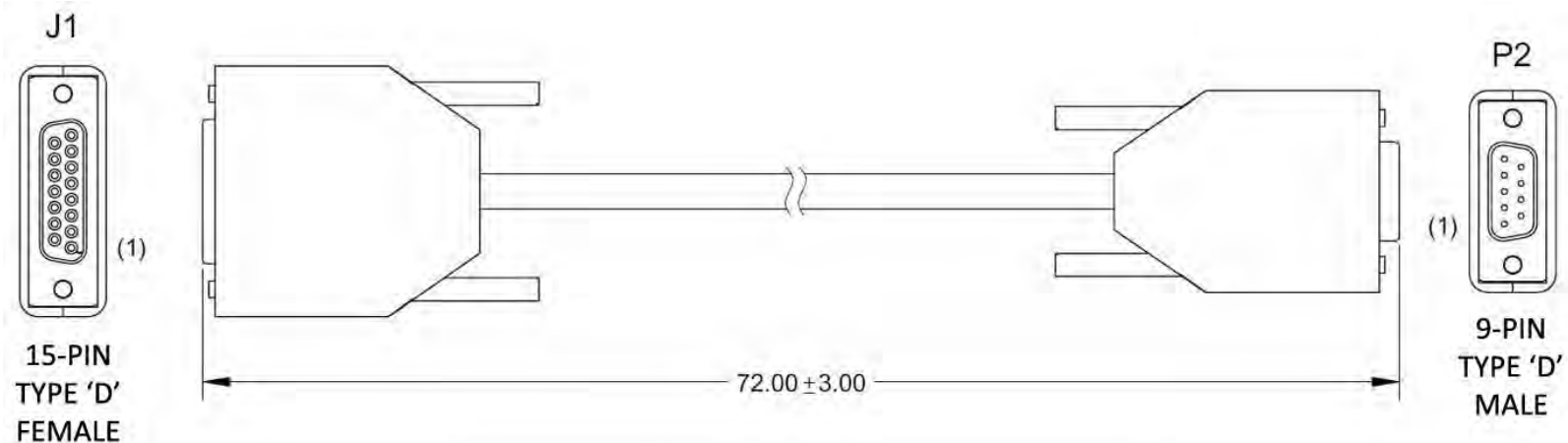


Figure B-17. Ethernet Data Cable for CDM-625/A (CA-0000121)

### B.4.6 Switch-to-Modem, Balanced G.703 Data Cable for CDM-625/A (DB-15F→DB-15M)

You may use this cable for Balanced G.703 data connection between the Switch and the CDM-625/A Modem.



WIRE LIST		
FROM	TO	COMMENTS
J1-1	P2-9	TWISTED PAIR
J1-9	P2-5	
J1-3	P2-1	TWISTED PAIR
J1-11	P2-6	
J1-5	P2-4	TWISTED PAIR
J1-12	P2-8	
J1-6	P2-7	TWISTED PAIR
J1-13	P2-2	
J1-2, J1-4	P2-3	SHIELD, ITEM 8
J1-7	N/C	-
J1-8	N/C	-
J1-10	N/C	-
J1-14	N/C	-
J1-15	N/C	-

Figure B-18. CDM-625/A Bal G.703 Data Cable (CA-000072)

### B.4.7 Switch-to-Modem / Modem-to-User, Gigabit Ethernet, Quad E1 RJ-48 Connector Cable (RJ-48M→RJ-48M)

You may use this cable for Gigabit Ethernet data connections for the SLM-5650/5650A, CDM-710G/710GL, CDM-710, and CDM-700 Modems, and for Quad E1 data connections for the CDM-Qx/QxL Modems.

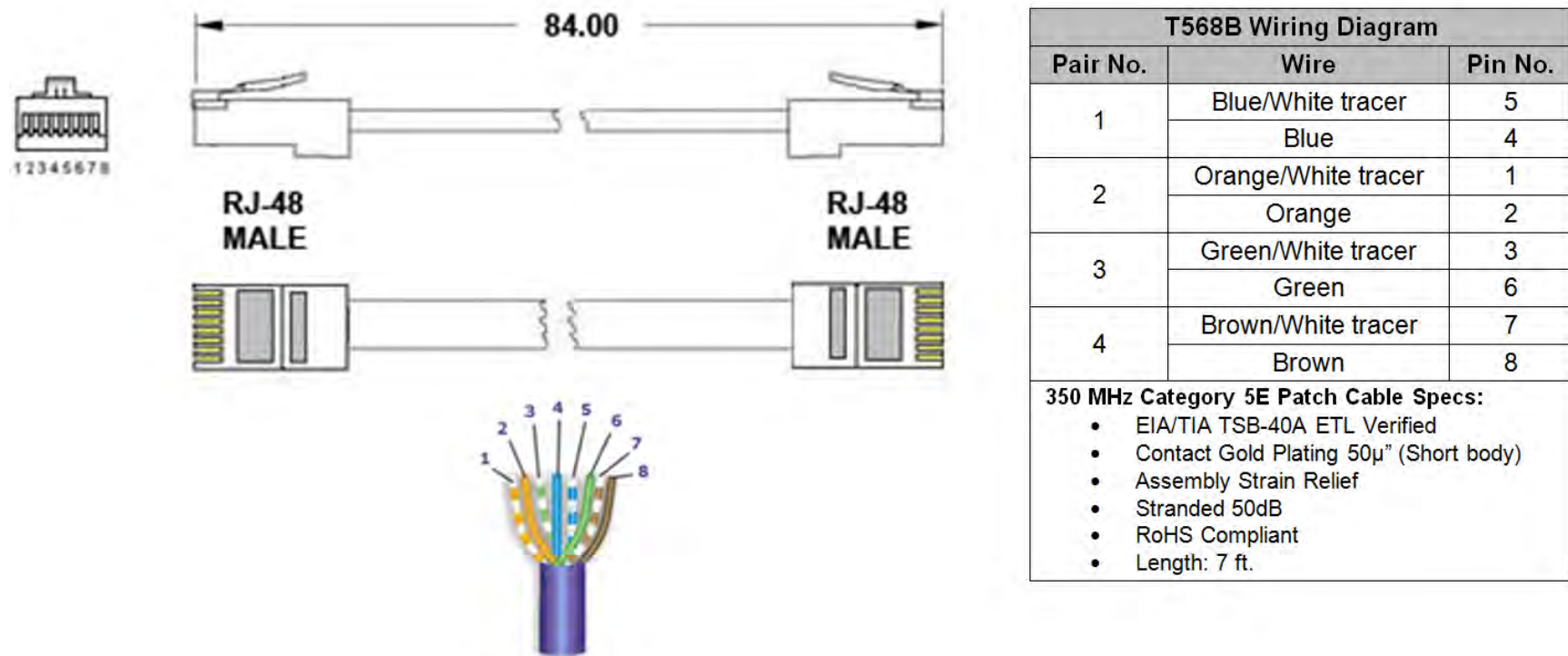


Figure B-19. Quad E1 / GigE Connector Cable (PP/CAT5FF7FTGY)

### B.4.8 Switch-to-Modem, HSSI Data Cable (HD-50M→HD-50M)

You may use this Type 'HD' 50-pin cable for HSSI data connections between the Switch and the Modem.

FROM	TO	SIGNAL	COLOR	PAIR
P1-1	P2-1	GND	BLK	
P1-26	P2-26	SIG GND	RED	X
P1-2	P2-2	RT	BLK	X
P1-27	P2-27		WHT	
P1-3	P2-3	CA	BLK	X
P1-28	P2-28		GRN	
P1-4	P2-4	RD	BLK	X
P1-29	P2-29		BLU	
P1-5	P2-5	OPEN	BLK	X
P1-30	P2-30		YEL	
P1-6	P2-6	ST	BLK	X
P1-31	P2-31		BRN	
P1-7	P2-7	SG	BLK	X
P1-32	P2-32		ORG	
P1-8	P2-8	TA	RED	X
P1-33	P2-33		WHT	
P1-9	P2-9	TT	RED	X
P1-34	P2-34		GRN	
P1-10	P2-10	LA	RED	X
P1-35	P2-35		BLU	
P1-11	P2-11	SD	RED	X
P1-36	P2-36		YEL	
P1-12	P2-12	LB	RED	X
P1-37	P2-37		BRN	
P1-13	P2-13	SG	RED	X
P1-38	P2-38		ORG	
P1-14	P2-14	OPEN	GRN	X
P1-39	P2-39		WHT	
P1-15	P2-15	OPEN	GRN	X
P1-40	P2-40		BLU	
P1-16	P2-16	OPEN	CRN	X
P1-41	P2-41		YEL	
P1-17	P2-17	OPEN	GRN	X
P1-42	P2-42		BRN	
P1-18	P2-18	OPEN	GRN	X
P1-43	P2-43		ORG	
P1-19	P2-19	SIG GND	WHT	X
P1-44	P2-44		BLU	
P1-20	P2-20	OPEN	WHT	X
P1-45	P2-45		YEL	
P1-21	P2-21	OPEN	WHT	X
P1-46	P2-46		BRN	
P1-22	P2-22	OPEN	WHT	X
P1-47	P2-47		ORG	
P1-23	P2-23	OPEN	BLU	X
P1-48	P2-48		YEL	
P1-24	P2-24	OPEN	BLU	X
P1-49	P2-49		BRN	
P1-25	P2-25	SIG GND	BLU	X
P1-50	P2-50		ORG	

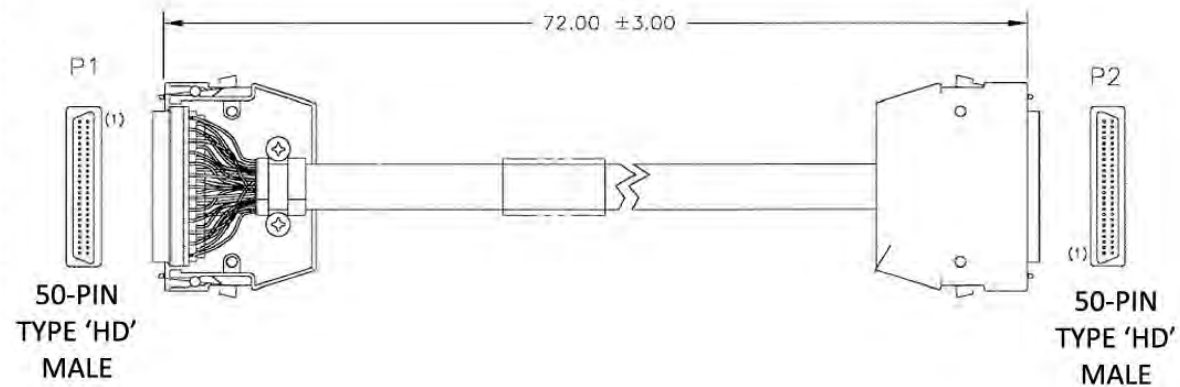


Figure B-20. HSSI Data Cable (CAWR9189-6)

### B.4.9 Switch-to-Modem, Quad E1 Data 'Y' Cable for CDM-625/A (DB-15F→2X DB-9M)

You may use this cable to connect the Quad E1 data between the Switch CRS-310 RMI and the CDM-625/A Modem.

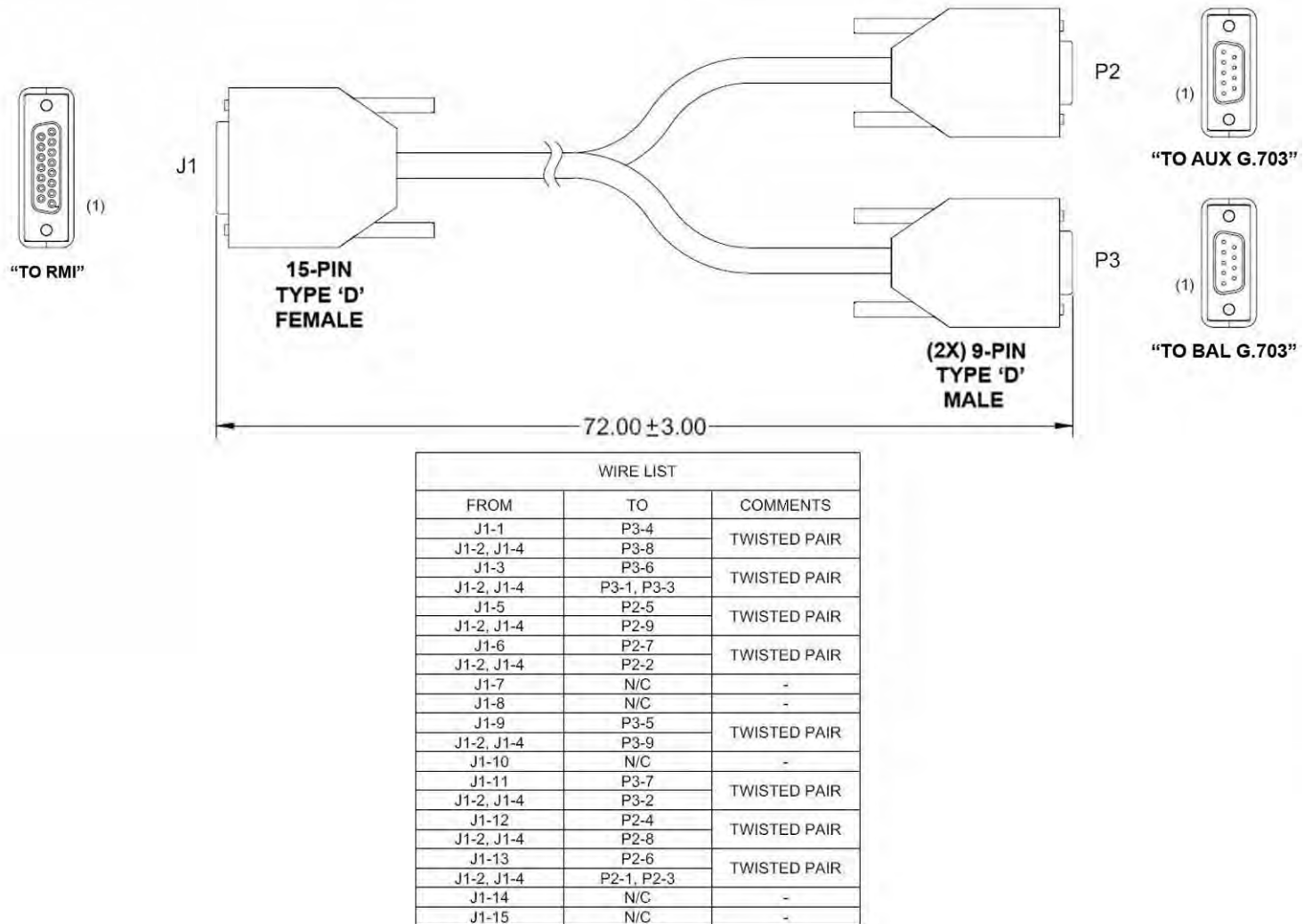


Figure B-21. CDM-625/A Quad E1 Data 'Y' Cable (CA-0000073)



### B.4.10 Modem-to-User, Quad E1 Data Cable for CDM-625/A (DB-9M→DB-9F)

You may use this Type 'D' 9-pin cable for the Quad E1 data connections between the Switch CRS-365D TMI and the CDM-625/A Modem.

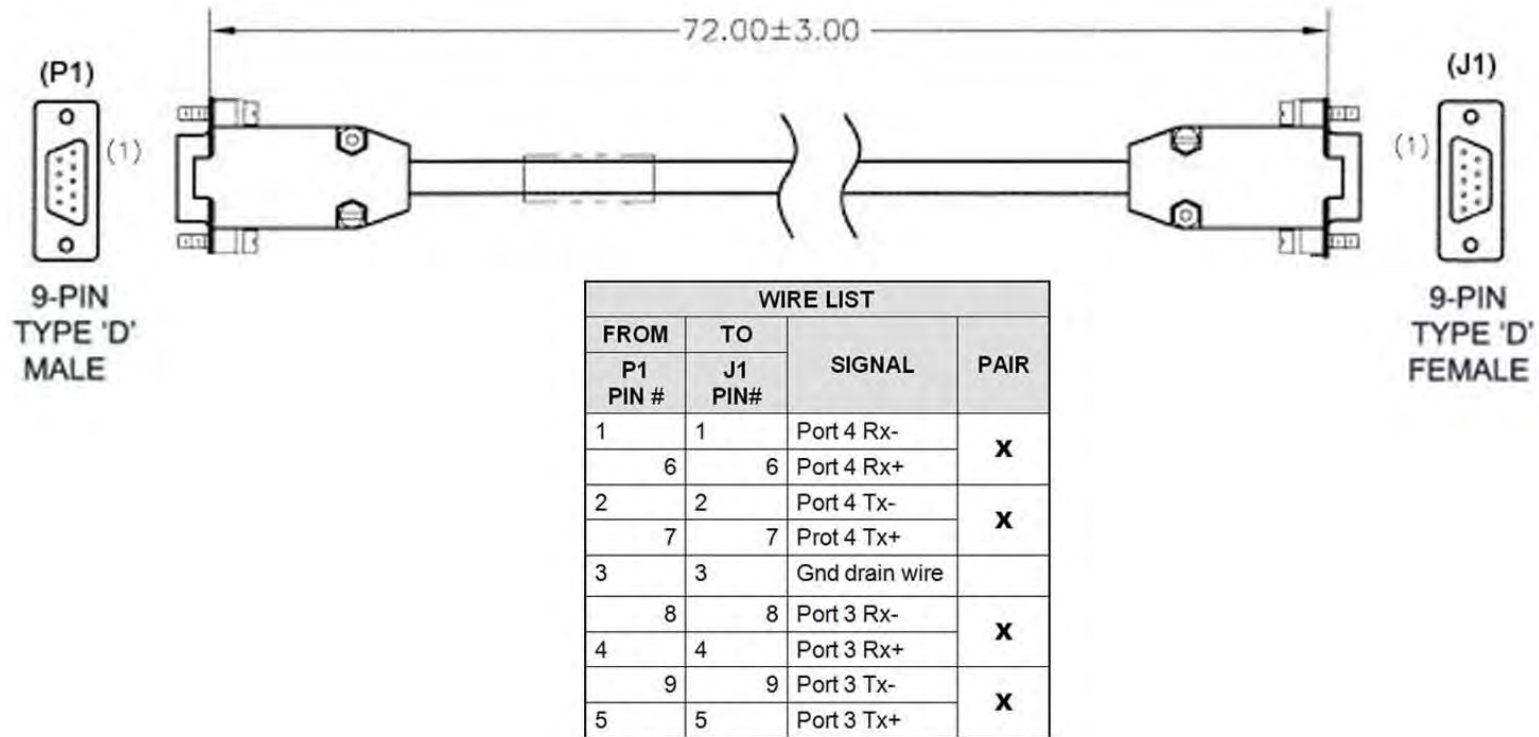


Figure B-22. CDM-625/A Quad E1 Data Cable (CA-0000136)

### B.4.11 Modem-to-User, Quad E1 Data Adapter Cable for CDM-625/A (DB-9M→2X DB-15F)

You may use this cable to adapt the Type 'D' 9-pin female Balanced G.703 or Auxiliary G.703 data connectors to a standard Type 'D' 15-pin connector pair for Quad E1 operation.

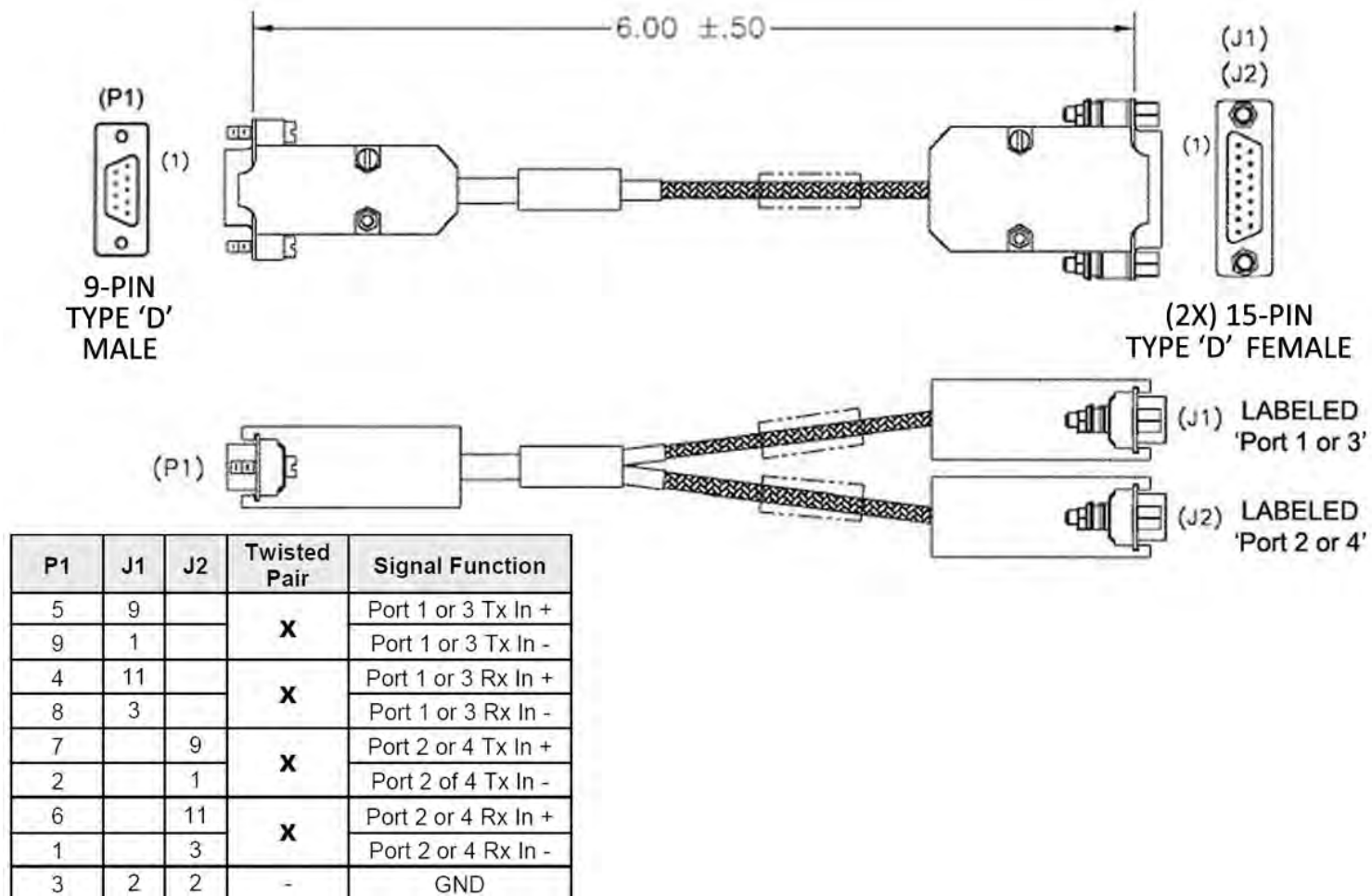


Figure B-23. CDM-625/A Quad E1 Data Adapter Cable (CA-0000163)

### B.4.12 Modem-to-User, Quad E1 Data Adapter Cable for CDM-625/A (DB-9M→2X RJ-48F)

You may use this cable to adapt the Type 'D' 9-pin female Balanced G.703 or Auxiliary G.703 data connectors to a standard RJ-48 connector pair for Quad E1 operation.

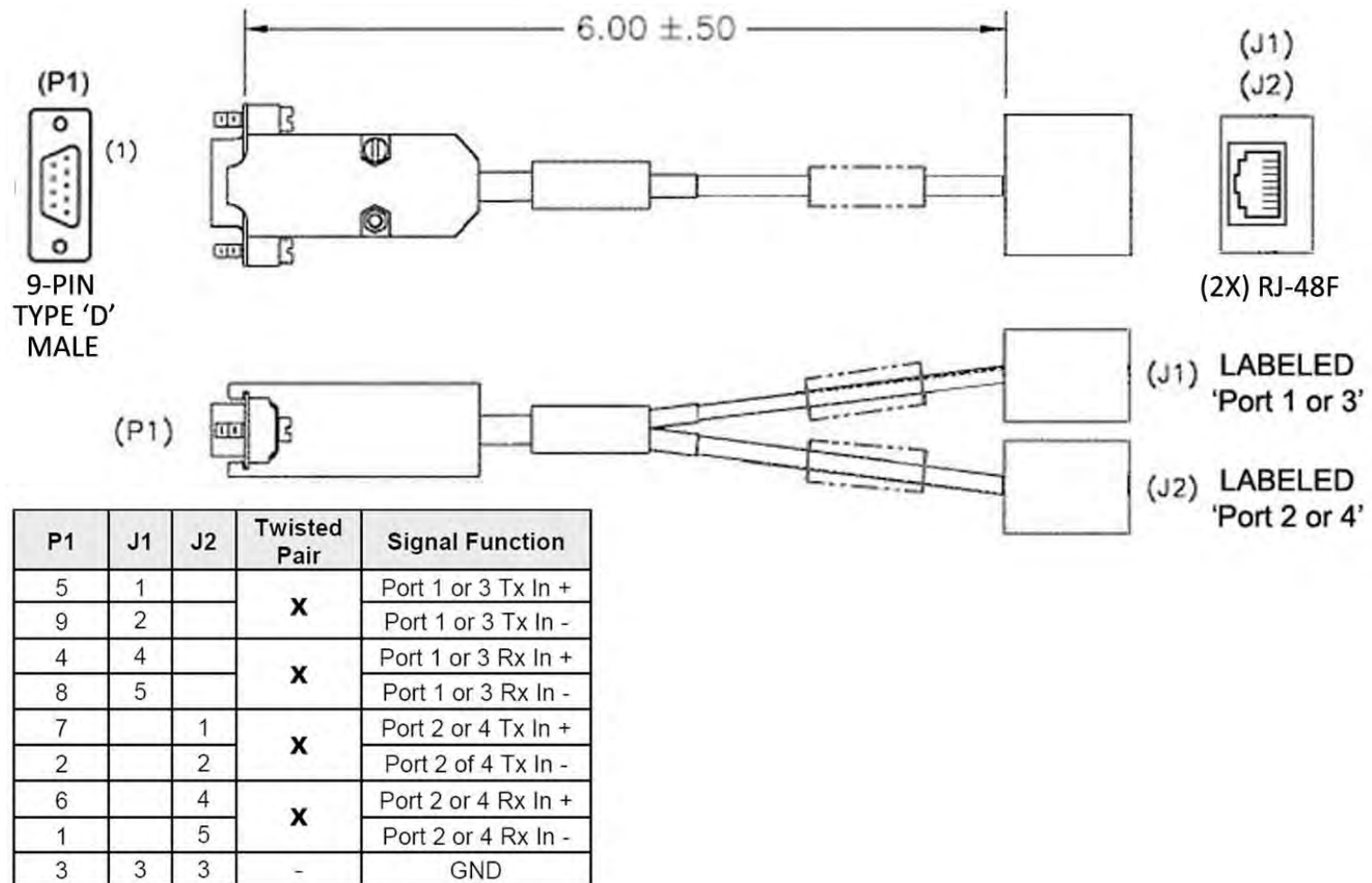


Figure B-24. CDM-625/A Quad E1 Data Adapter Cable (CA-0000164)

### B.4.13 Modem-to-Switch (CDM-625/A to CRS-350), Overhead Data Cable (DB-44M, DB-9M→DB-9F, DB-25M, DB-15F)

You may use this multi-purpose cable to connect the CDM-625/A Modem to the CRS-350 ESC Switch .

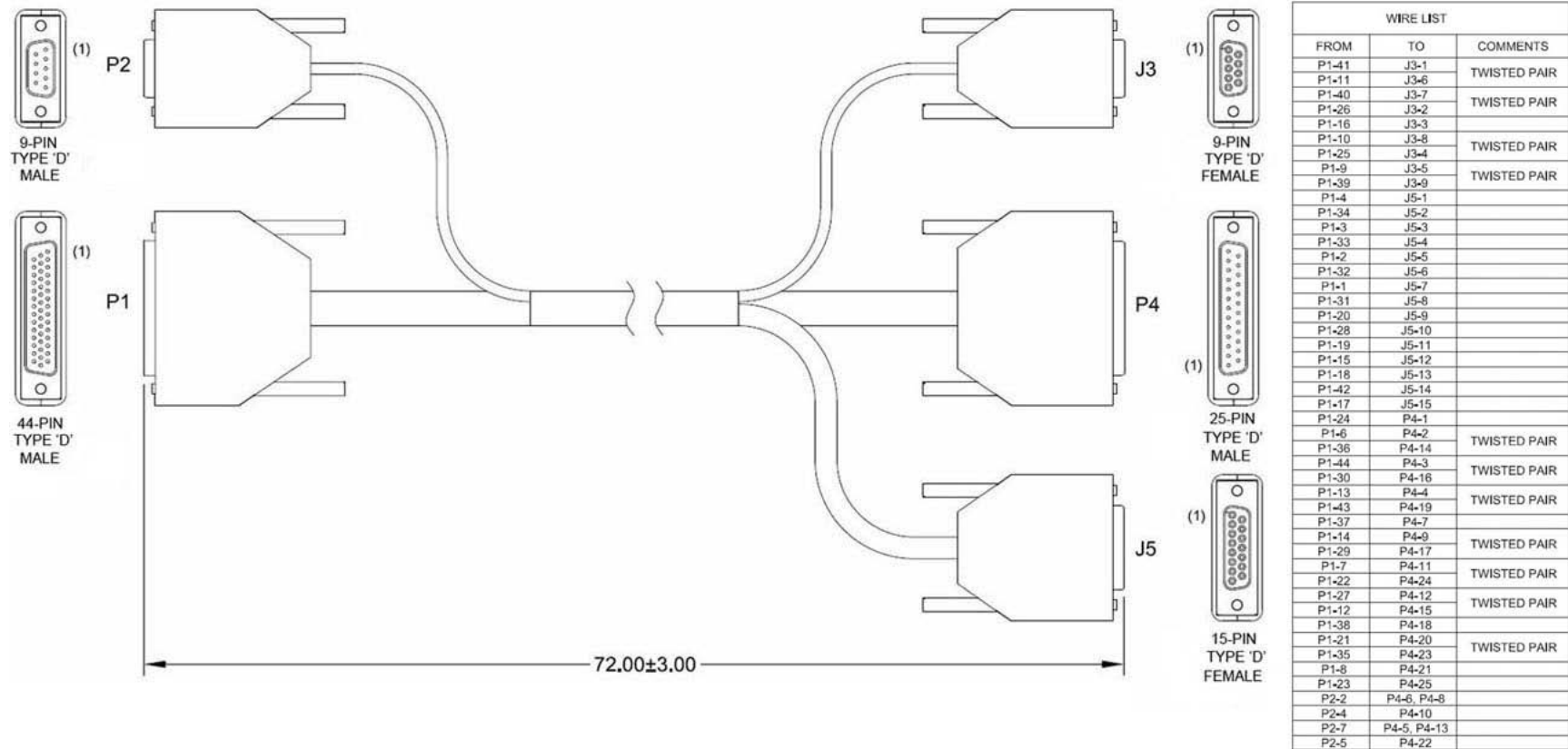


Figure B-25. CDM-625/A to CRS-350 Multi-purpose Cable (CA-0000074)

### B.4.14 Switch-to-User / Switch-to-Modem, Balanced G.703 Data Cable (DB-15M→DB-15F)

You may use this Type 'D' 15-pin cable for Balanced G.703 data connections between the Switch and User data, or between the Switch and SLM-5650/5650A, CDM-Qx/QxL, and CDM-600/L Modems.

INDICATORS		
15M	NOTES	15M
1	TO	1
2	TO	2
3	TO	3
4	TO	4
5	TO	5
6	TO	6
7	TO	7
9	TO	9
11	TO	11
12	TO	12
13	TO	13
15	TO	15

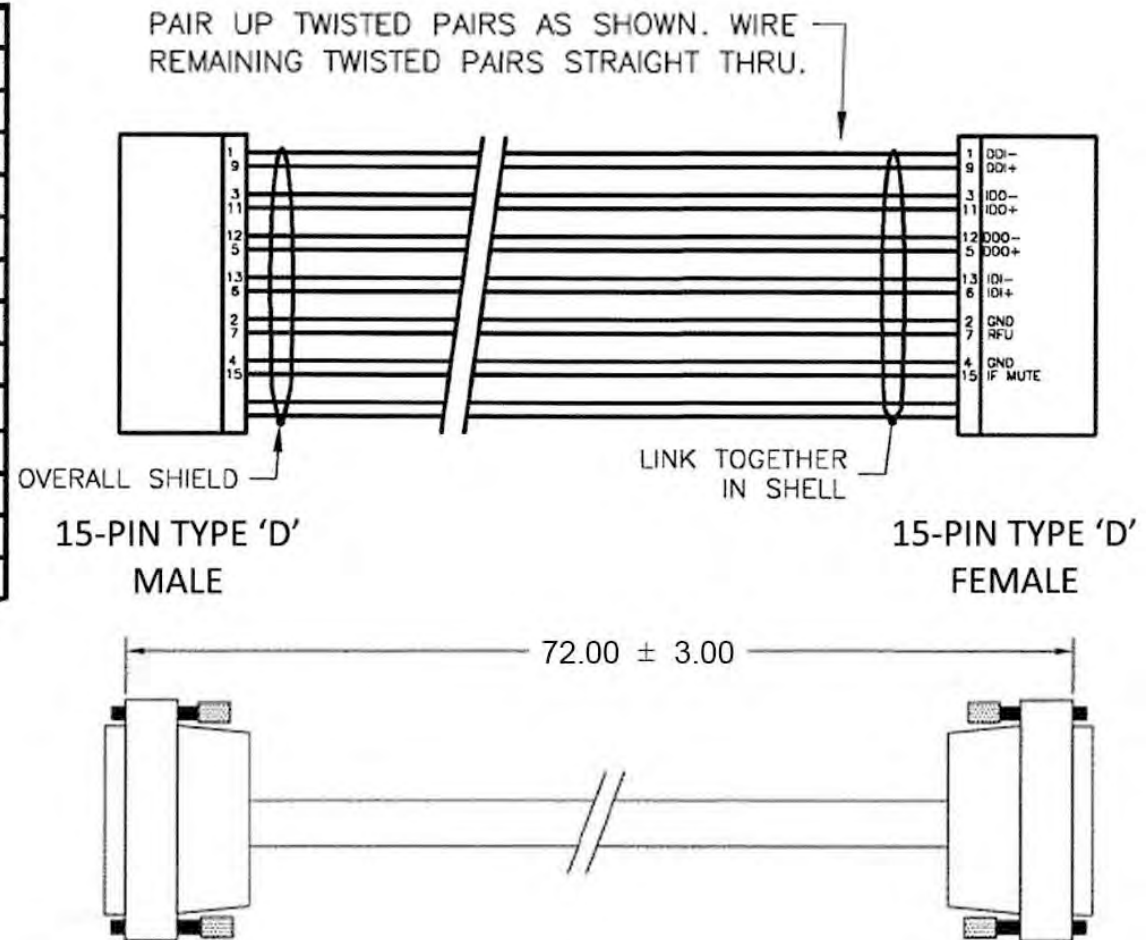


Figure B-26. Balanced G.703 Data Cable (CA/WR9038-6)

### B.4.15 Switch-to-Modem / Switch-to-User, Balanced G.703 Data Cable for CDM-570/A, CDM-570L/AL (DB-15M→DB-15F)

You may use this Type 'D' 15-pin cable for Balanced G.703 data connections between the Switch and CDM-570/A or CDM-570L/AL Modems or between the Switch and the user data.

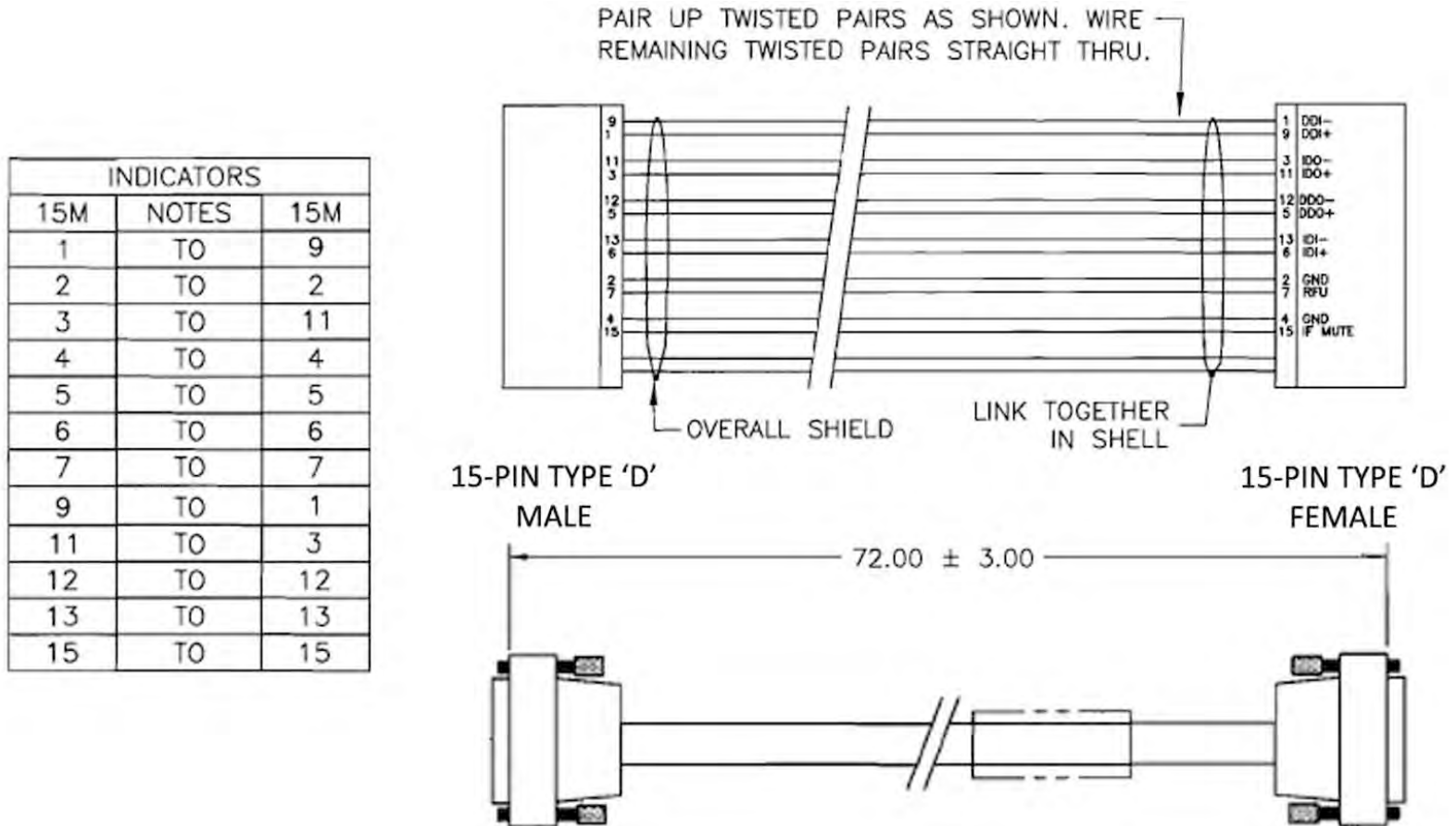


Figure B-27. CDM-570/A, CDM-570L/AL Balanced G.703 Data Cable (CA/WR11999-6)

### B.4.16 Modem-to-User, Optional T1/E1 Adapter for CDM-570/A, CDM-570L/AL, CDM-600/L (DB-15M→RJ-48F)

You may use this optional adapter to convert the Type 'D' 15-pin female Balanced G.703 data connector on the User side of the Switch TMI to a standard RJ-48 female port for T1/E1 operation.

WIRE LEGEND			
RJ-48 PIN #	DB-15M PIN #	WIRE COLOR	SIGNAL NAME
1	9	BLUE	Tx+
2	1	ORANGE	Tx-
3	2	BLACK	GND
4	11	RED	Rx+
5	3	GREEN	Rx-
6	4	YELLOW	GND
7		BROWN	NC
8		WHITE	NC

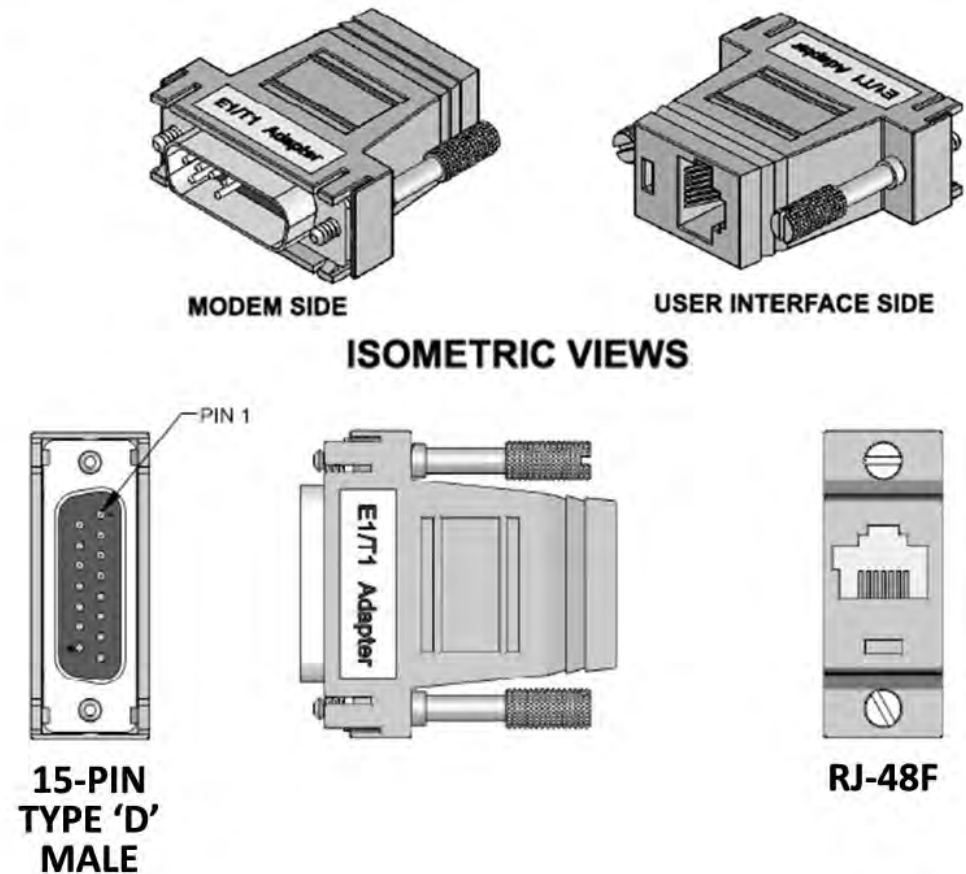


Figure B-28. Optional T1/E1 Adapter (CN-0000268)

### B.4.17 Switch-to-Modem, Quad E1 Data Cable for CDM-Qx/QxL (DB-15F→4X RJ-45M)

You may use this cable to connect the Switch CRS-305 RMI to the redundant CDM-Qx/QxL Quad E1 interface.

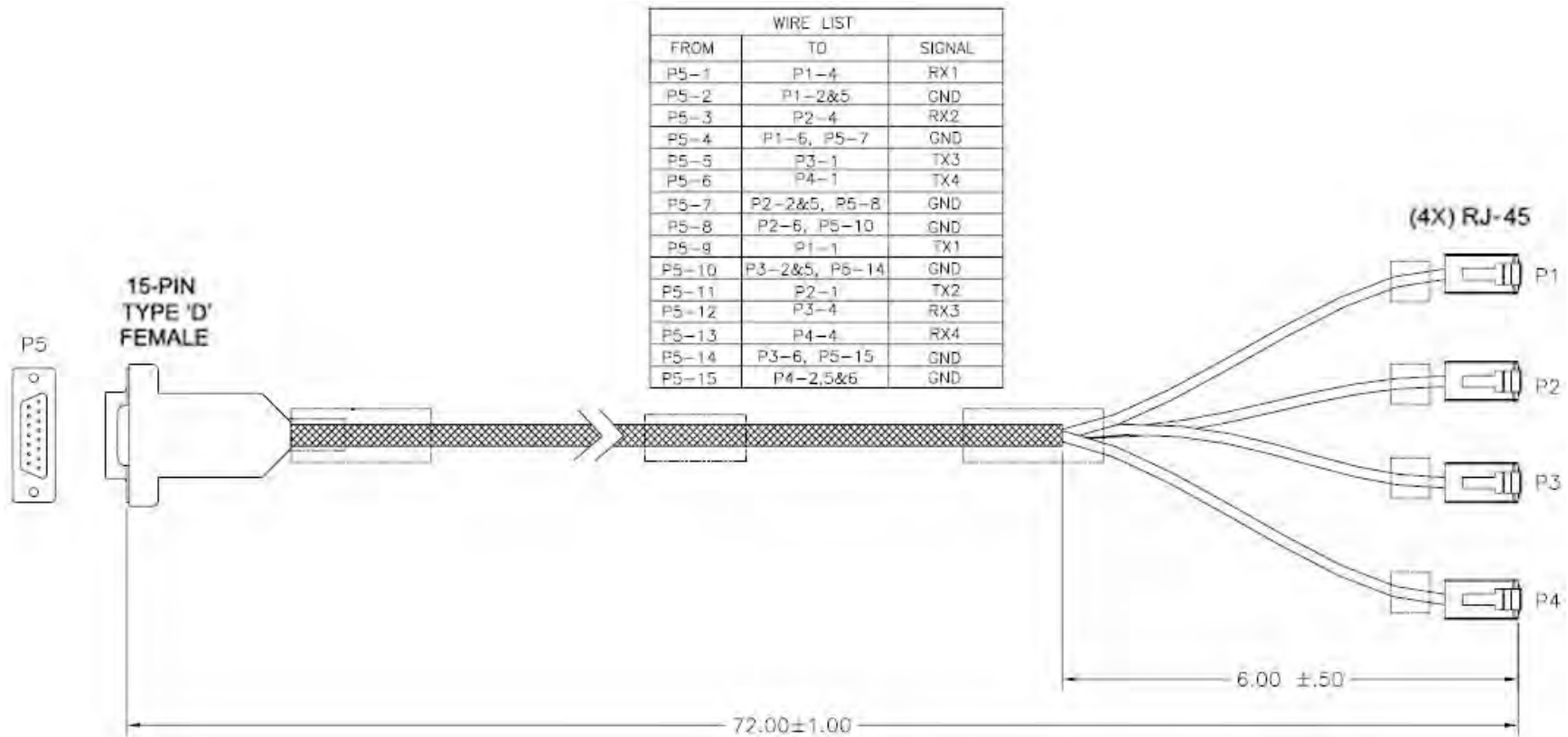


Figure B-29. CDM-Qx/QxL Quad E1 Data Cable (CAWR13018-1)



### B.4.18 Switch-to-Modem, G.703 Data Cable for CDM-700 (DB-9F→8X BNC 75Ω Male)

You may use this cable to connect the Switch CRS-345 TMI Type 'D' 9-pin female connector to the Traffic CDM-700 G.703 Interface module BNC ports. Certain modem configurations require a modified version of this cable that use only four of the eight BNC connectors. See **Chapter 4.10 CDM-700 Modem Connections** for examples of this alternate use.

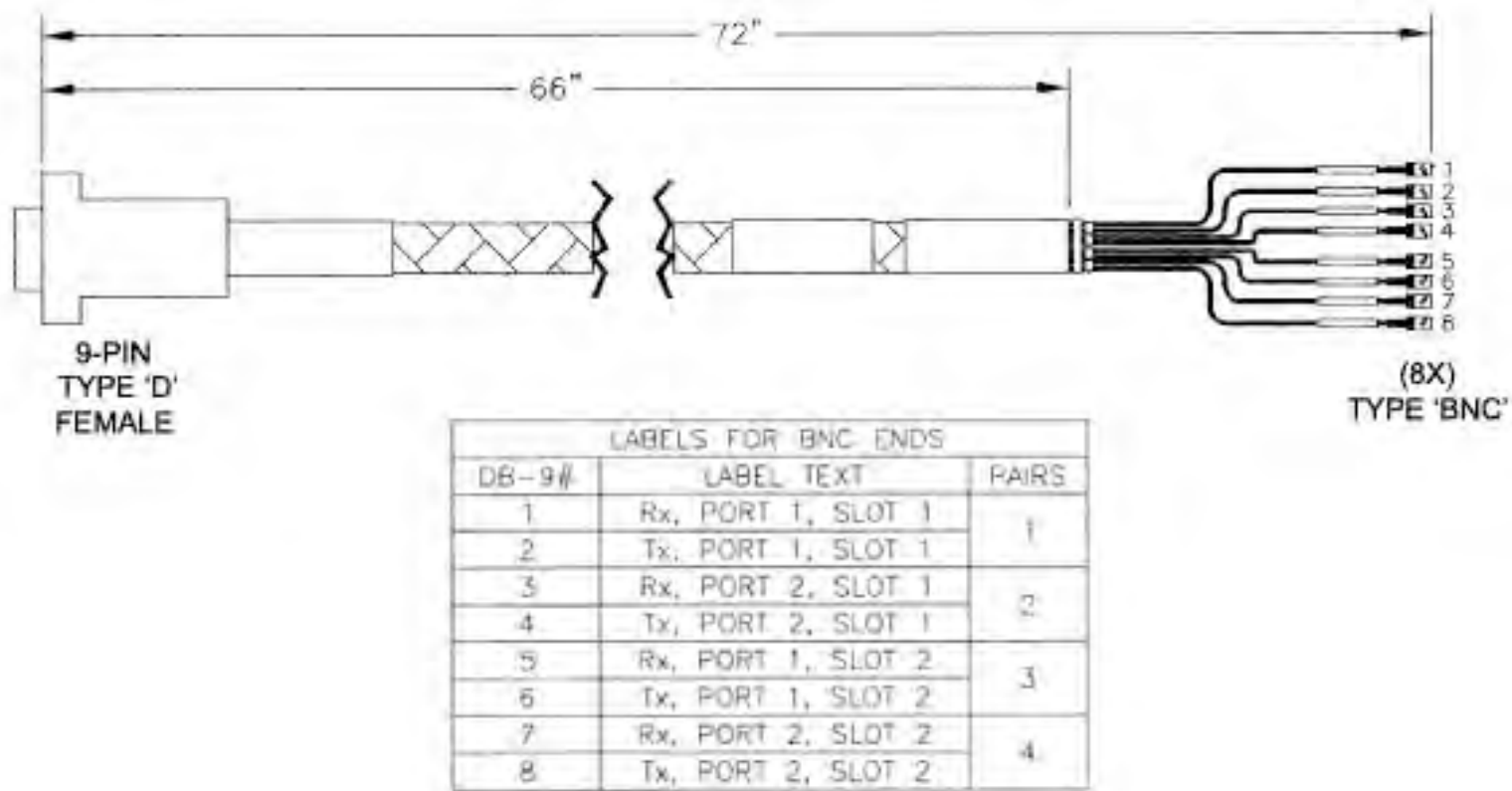


Figure B-30. CDM-700 G.703 Data Cable (CA/RF12278-1)

### B.4.19 Switch-to-Modem, G.703 Data Cable for CDM-700 (DB-15F→8X BNC 75Ω Male)

You may use this cable to connect the Switch CRS-306 RMI Type 'D' 15-pin female connector to the Redundant CDM-700 G.703 Interface module BNC ports. Certain modem configurations require a modified version of this cable that use only four of the eight BNC connectors. See **Chapter 4.10 CDM-700 Modem Connections** for illustrations of this alternate use.

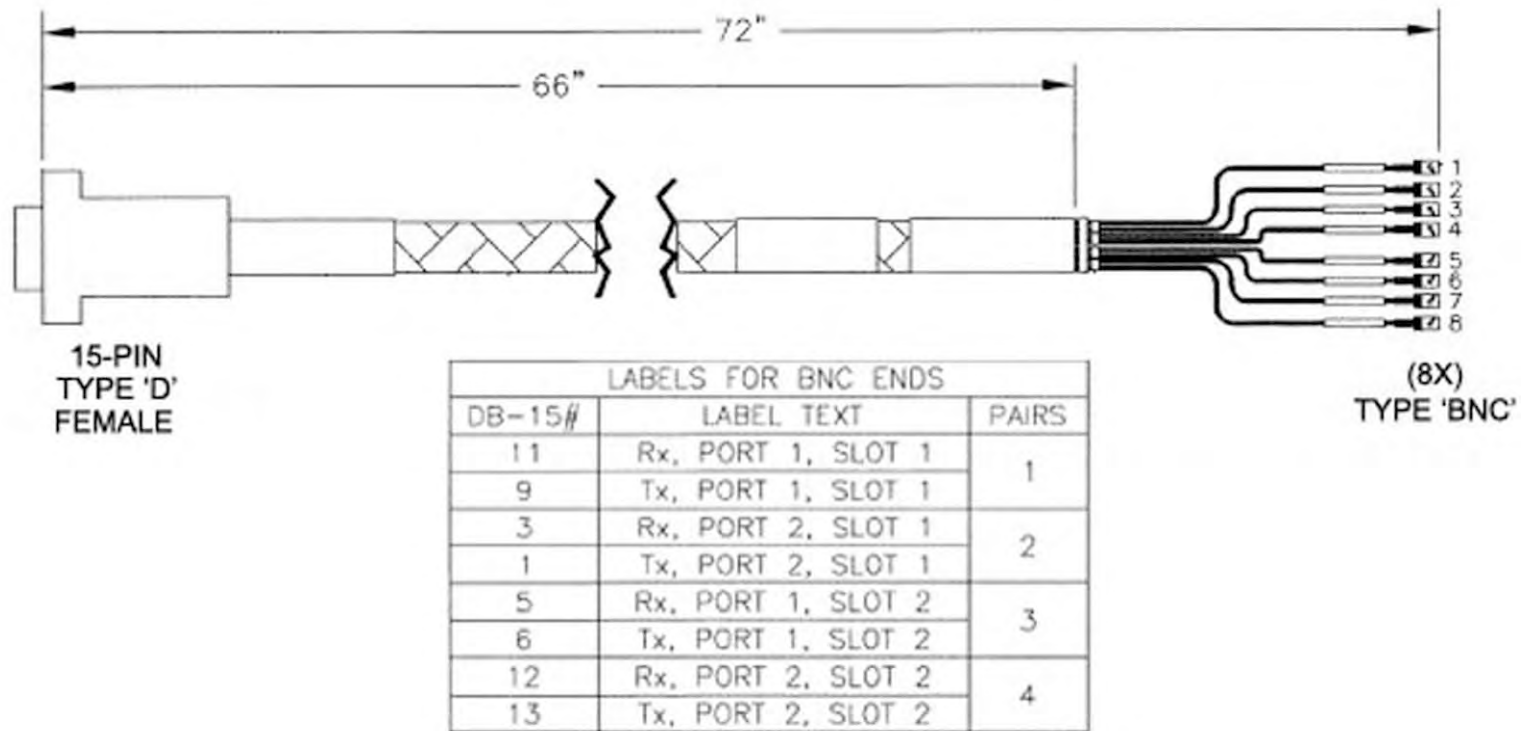


Figure B-31. CDM-700 G.703 Data Cable (CA/RF12279-1)

### B.4.20 Switch-to-Modem, Audio Data Cable for CDM-600/L (DB-9M→DB-9F)

You may use this Type 'D' 9-pin cable for Audio data connections between the CRS-350 ESC Switch and CDM-600/L Modems.

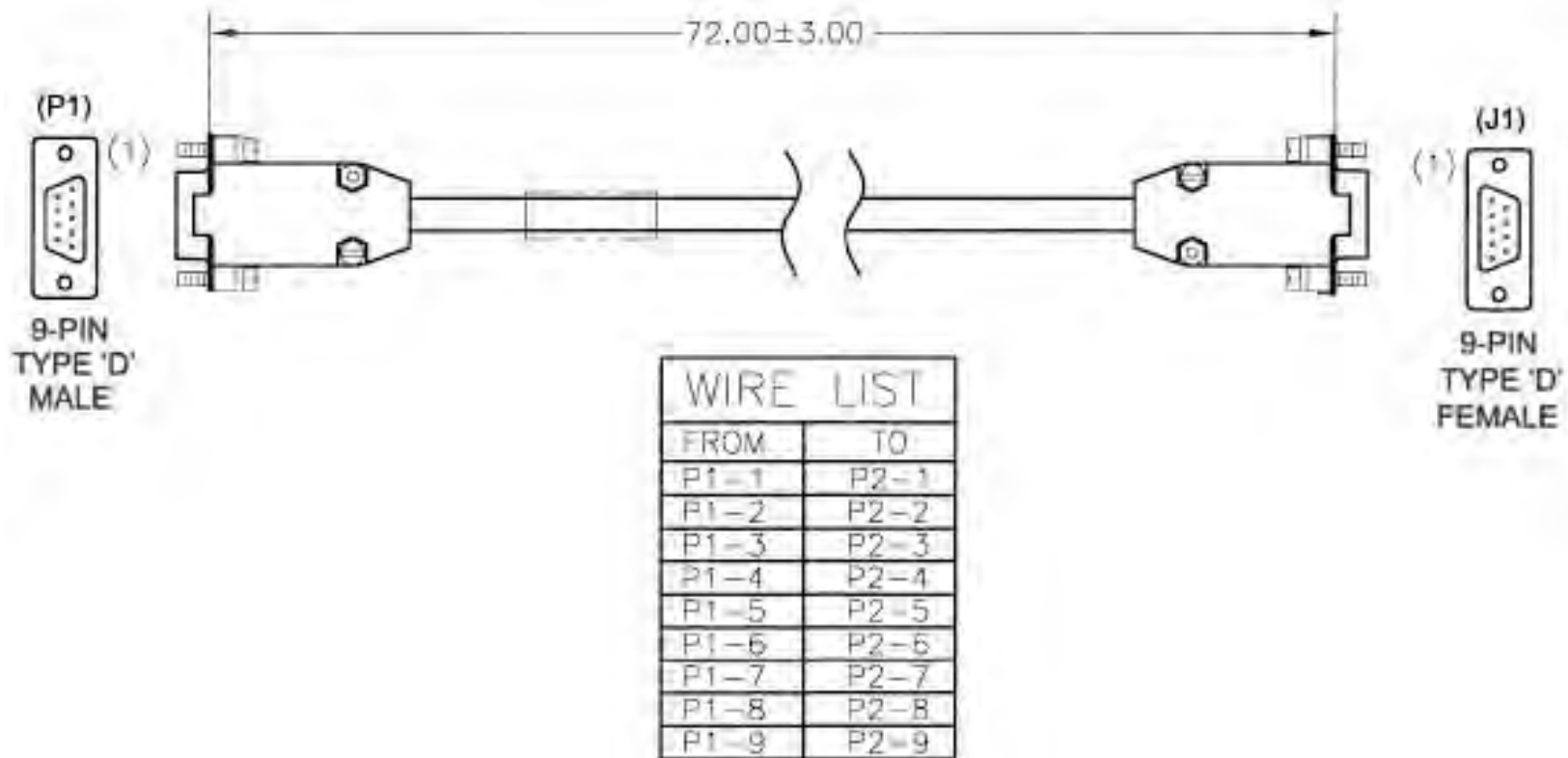


Figure B-32. CDM-600/L Audio Data Cable (CA/WR9932-1)



# Appendix C. ADDRESSING SCHEME INFORMATION

---

## C.1 Addressing Overview

A CRS-300 1:10 Redundancy Switch provides 1:10 redundancy; that is, you may use the CRS-300 to control one Redundant Modem and up to 10 Traffic Modems.

You can remotely communicate to the Switch or any of the modems, via the DB-9, EIA-232 or EIA-485 remote connector on the CRS-230 Switch Controller card (installed in the CRS-300). A direct User-to-modem connection is not permissible in this configuration – master operation is restricted to the Switch in a redundancy system.

For Switch-to-modem communications with the CDM-625/A, CDM-570/A, CDM-570L/AL, SLM-5650/5650A, CDM-710, CDM-700, and CDM-600/L modems, the Switch uses serial communications via a DB-25 data cable or an HD-15 Control Cable that is connected between each modem and the Switch-installed TMIs.

For Switch-to-modem communications with the CDM-Qx/QxL modems, the Switch uses EIA-485 communications via a DB-9 multi-drop cable that is connected from the “485 Pass-Through” connector on the CRS-230, and then daisy-chained to each of the modems.

For modems that are configured for EDMAC framing, Monitor & Control (M&C) information may be communicated to the modems and transceivers at the distant-end of the link. In order for an M&C application to be able to communicate with the various devices connected to the Switch, the correct addresses must be used.

This appendix provides details of the address requirements to allow M&C of the Switch, various modems, and transceivers that may be included in a CRS-300 1:N Redundancy System.

## C.1.1 Switch Addresses

The permitted Switch remote control addresses are limited:

- For EIA-485 connections, the only permitted addresses are 1000, 3000, 5000, and 7000.
- For EIA-232, the only permitted address is 0000.



**The Switch settings for external communications are totally independent from the internal communication between Switch and traffic modems**

## C.1.2 Modem and Transceiver Addresses

To monitor and control modems and transceivers at the distant-end of the communication link, EDMAC must be enabled, via the modem front panel, in local mode. Set the Tx and Rx parameters to establish the link on the modems on each end of the link. Then an M&C application can be used. Examples of EIA-232 and EIA-485 addressing schemes are illustrated in the diagrams that follow.

These diagrams include the following terminology:

Abbreviation	Explanation
<b>MCA</b>	Monitor & Control Address, to be entered as the address of a unit into an M&C application, e.g., SatMac.  Modem addresses are automatically assigned by the TMI/RMI slot positions to which they are associated within a Switch.  When using EIA-485 multi-drop, you may change the Switch bus address to 1000, 3000, 5000, 7000, or 9000 (7000 is shown in the figures in this appendix as an example only).
<b>RCA</b>	Remote Control Address, to be configured, via the unit front panel (CONFIG:REMOTE)
<b>ESA</b>	EDMAC Slave Address (Range) Local modem is configured as EDMAC master Distant-end modem is an EDMAC slave

CDM-625/A, CDM-570/A, CDM-570L/AL, and CDM-600/L modems employ a point-to-point internal serial communication bus within the DB-25 or DB-9 cable to the Switch. **Figure C-1** shows the external EIA-232 addressing scheme for these modems; **Figure C-2** depicts the external EIA-485 connection for this configuration.

SLM-5650/5650A and CDM-7XX modems employ a point-to-point internal serial communications bus within the HD-15 cable to the Switch. **Figure C-3** shows the external EIA-232 addressing scheme for these modems; **Figure C-4** depicts the external EIA-485 connection for this configuration.

CDM-Qx/QxL modems require an external multi-drop EIA-485 connection. **Figure C-5** shows the external EIA-232 addressing scheme for a system comprising these modems with a Switch; **Figure C-6** depicts the external EIA-485 connection for this configuration. See **Figure C-7** for a distant-end CRS-300/Qx/QxL setup using Traffic modems in EDMAC Slave Mode.

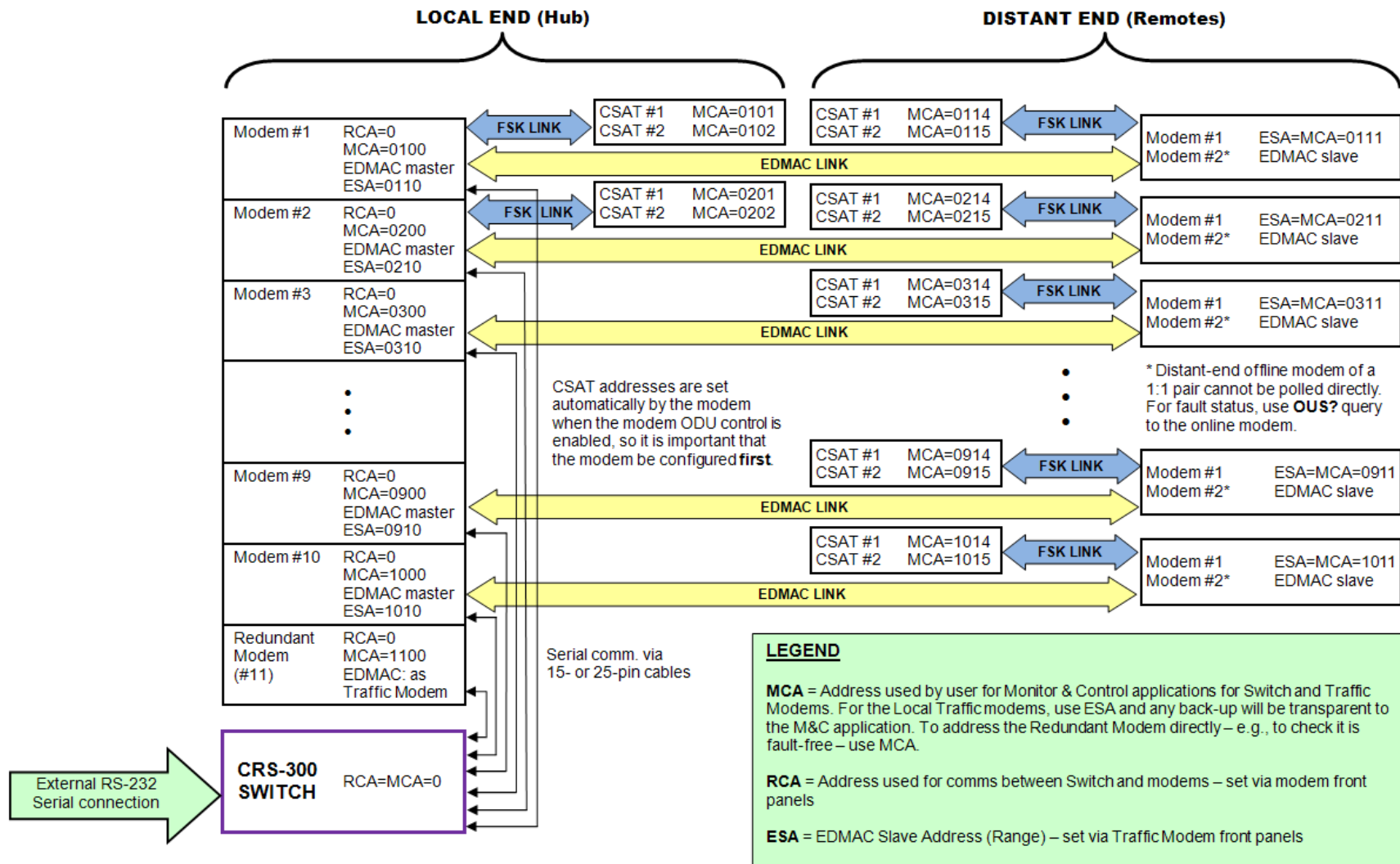


Figure C-1. CRS-300 Addressing Scheme Example: External EIA-232 with CDM-625/A, -570/A, -570L/AL, -600/L Modems

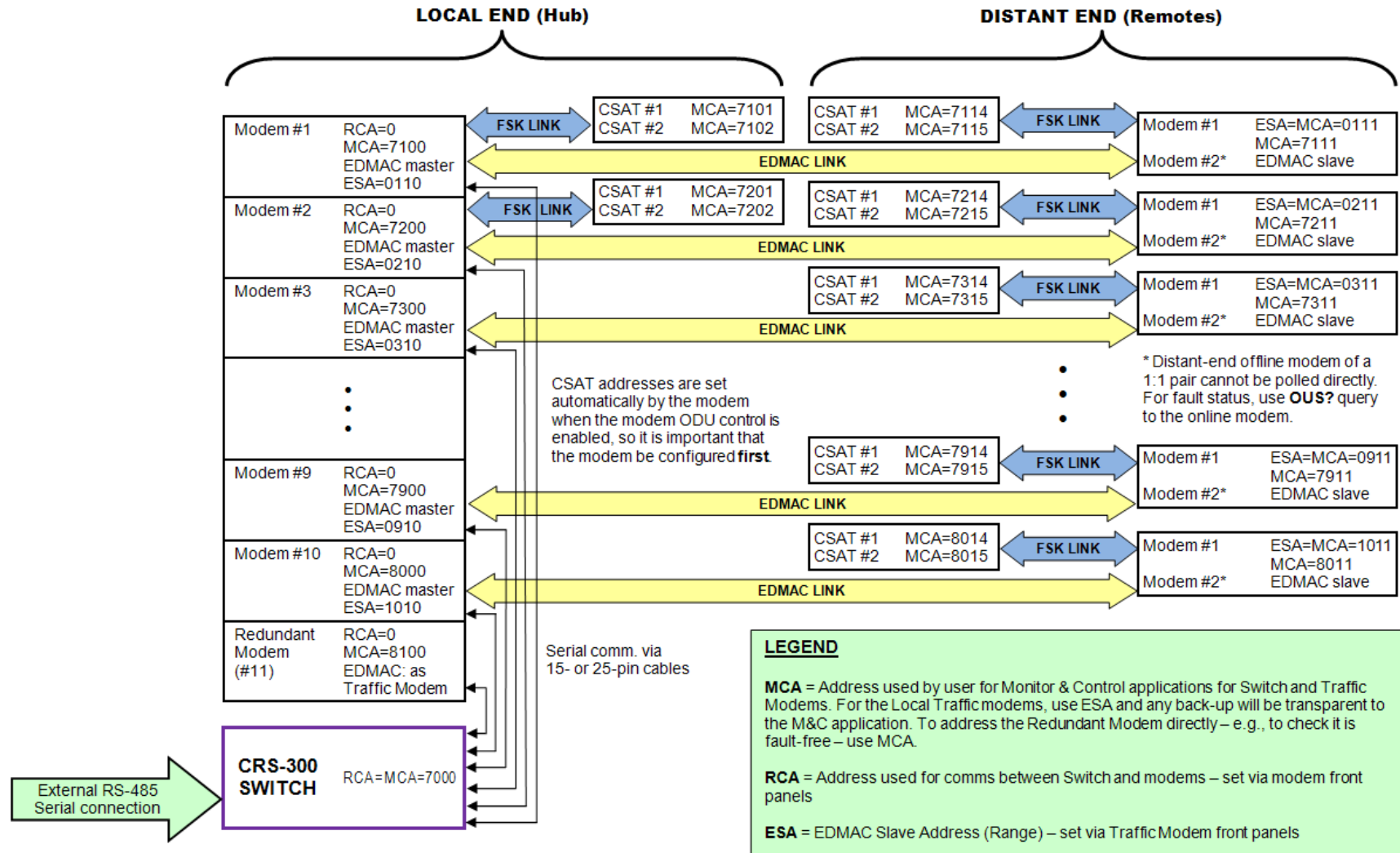


Figure C-2. CRS-300 Addressing Scheme Example: External EIA-485 with CDM-625/A, -570/A, -570L/AL, -600/L Modems



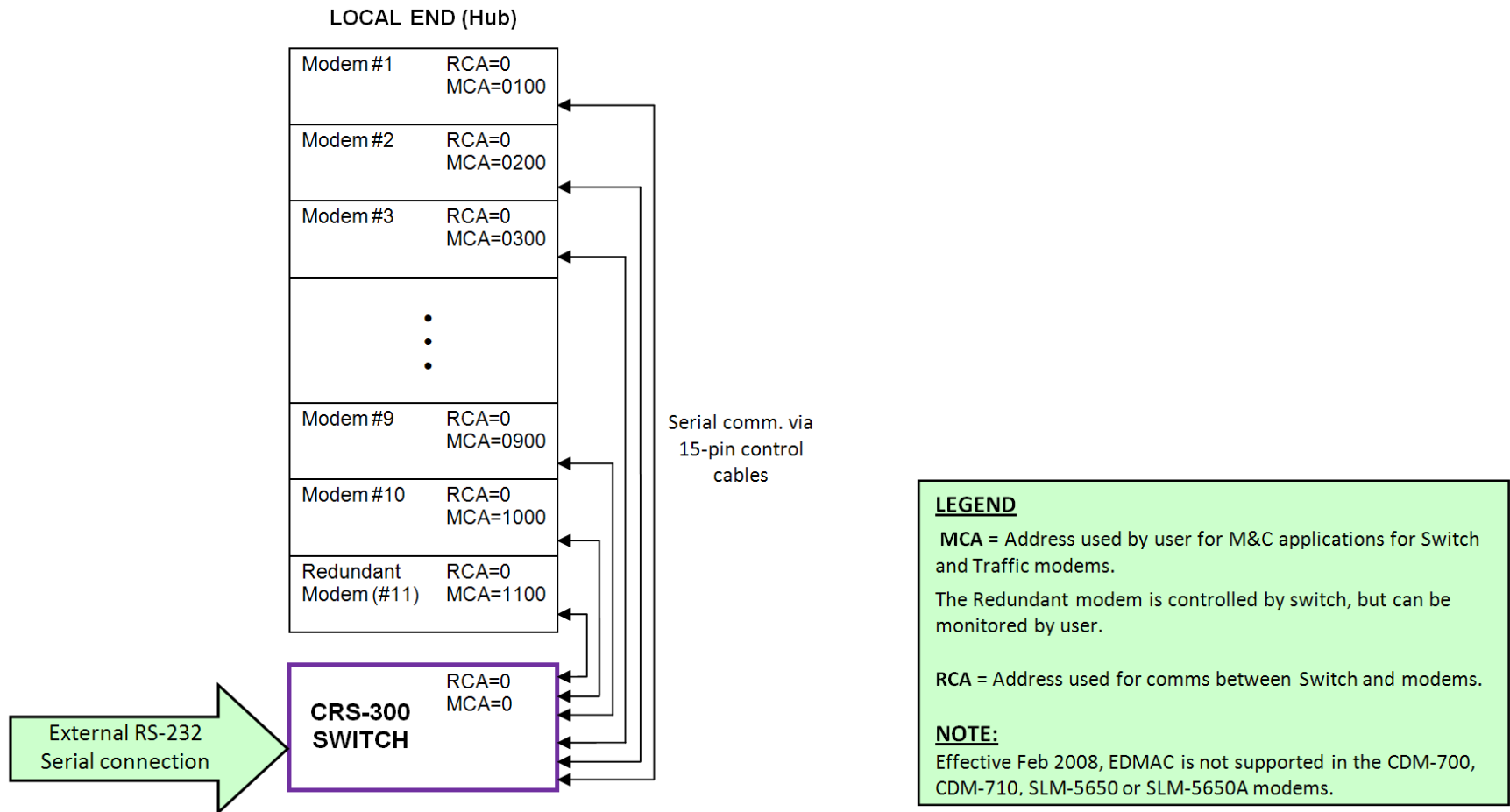


Figure C-3. CRS-300 Addressing Scheme Example: External EIA-232 with SLM-5650/5650A, CDM-7XX Modems

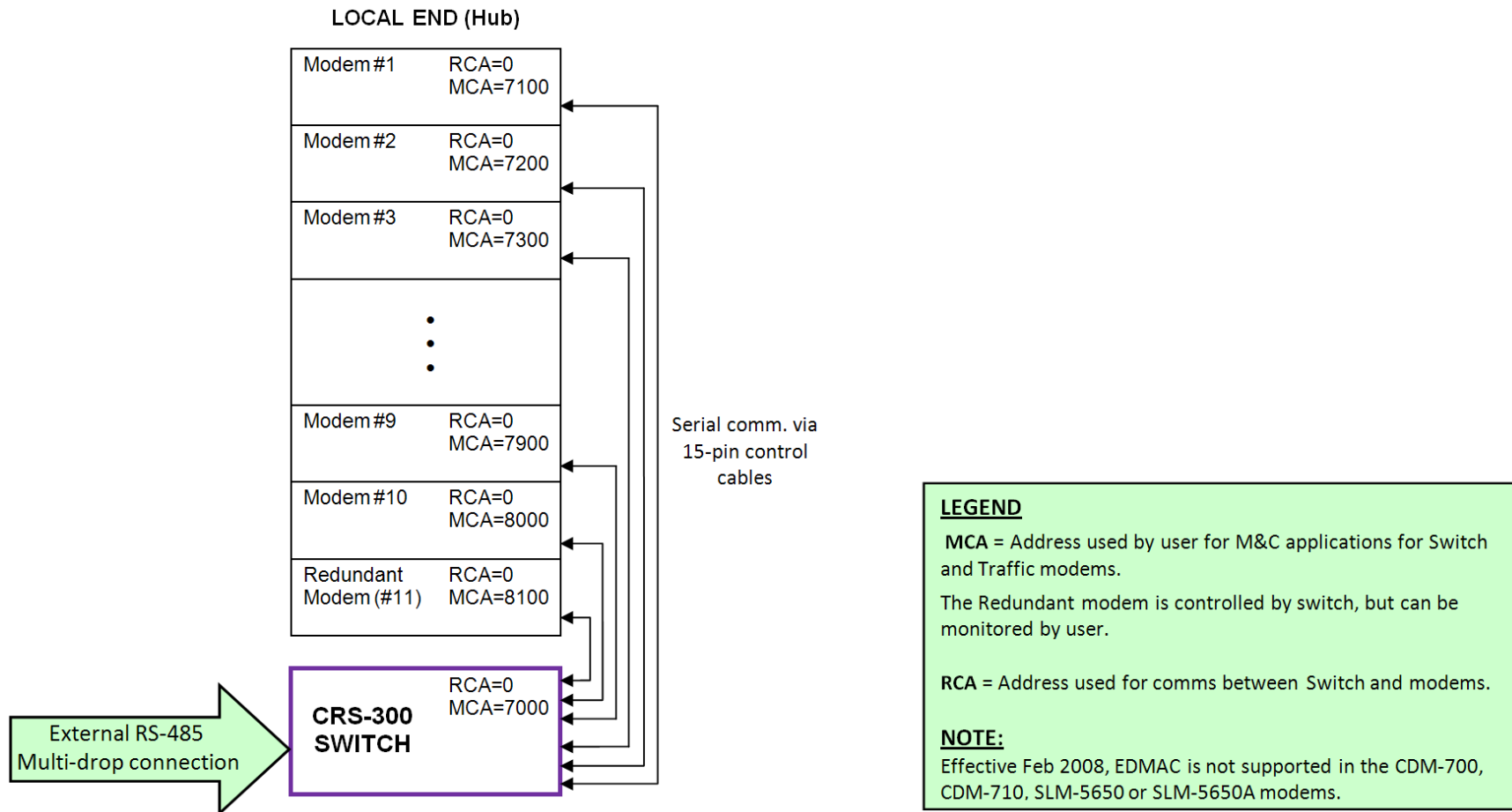


Figure C-4. CRS-300 Addressing Scheme Example: External EIA-485 with SLM-5650/5650A, CDM-7XX Modems

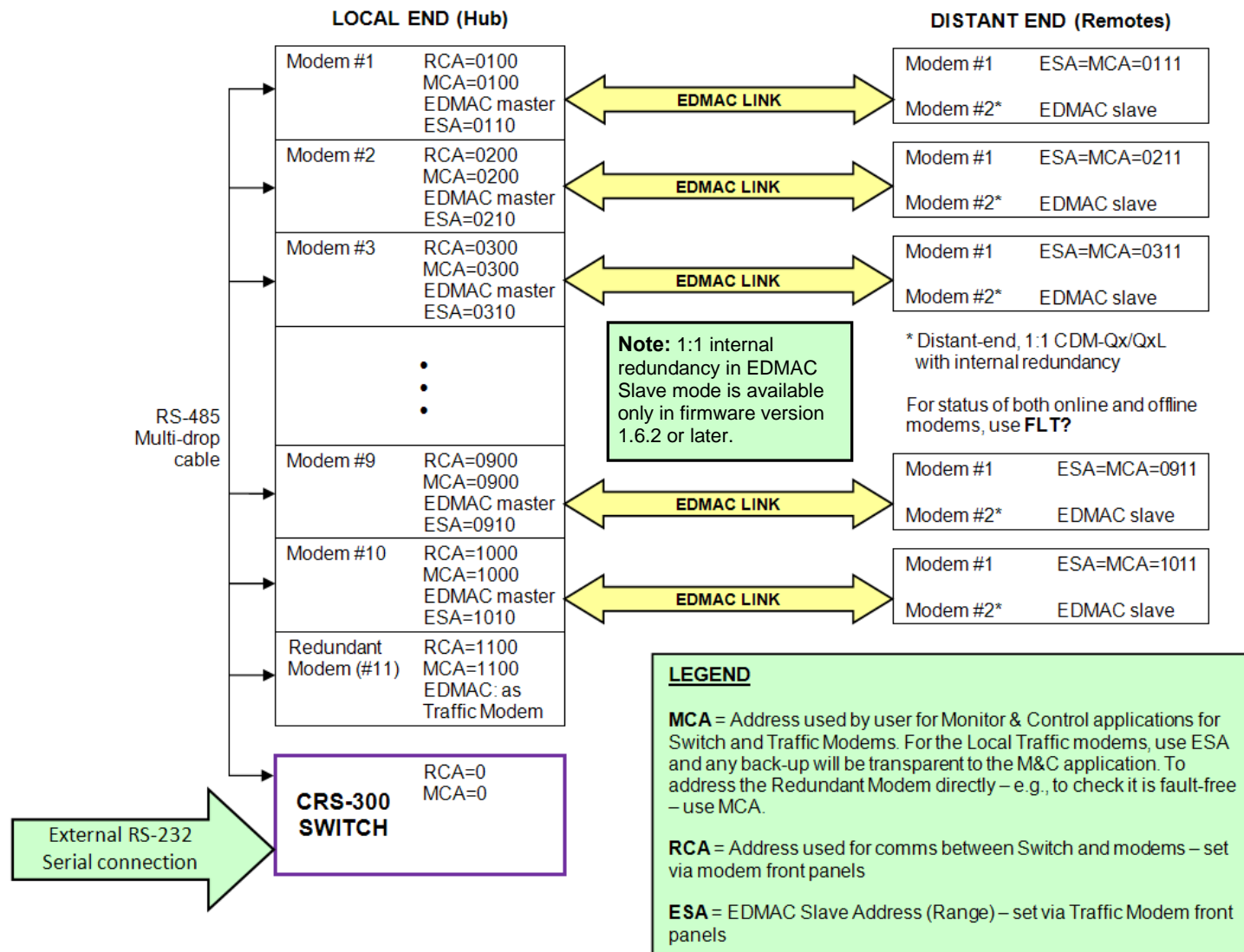


Figure C-5. CRS-300 Addressing Scheme Example: External EIA-232 with CDM-Qx/QxL Modems

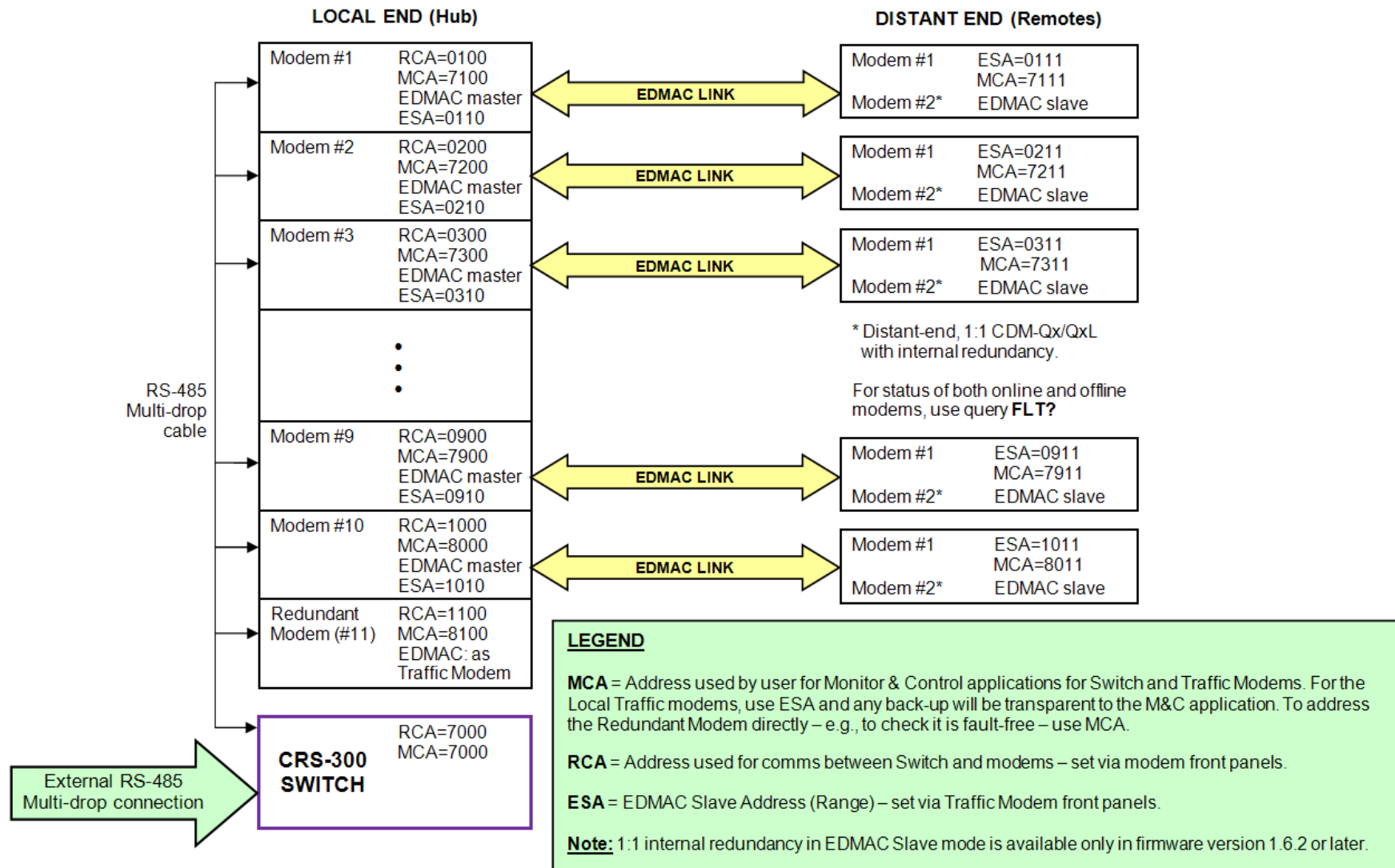


Figure C-6. CRS-300 Addressing Scheme Example: External EIA-485 with CDM-Qx/QxL Modems

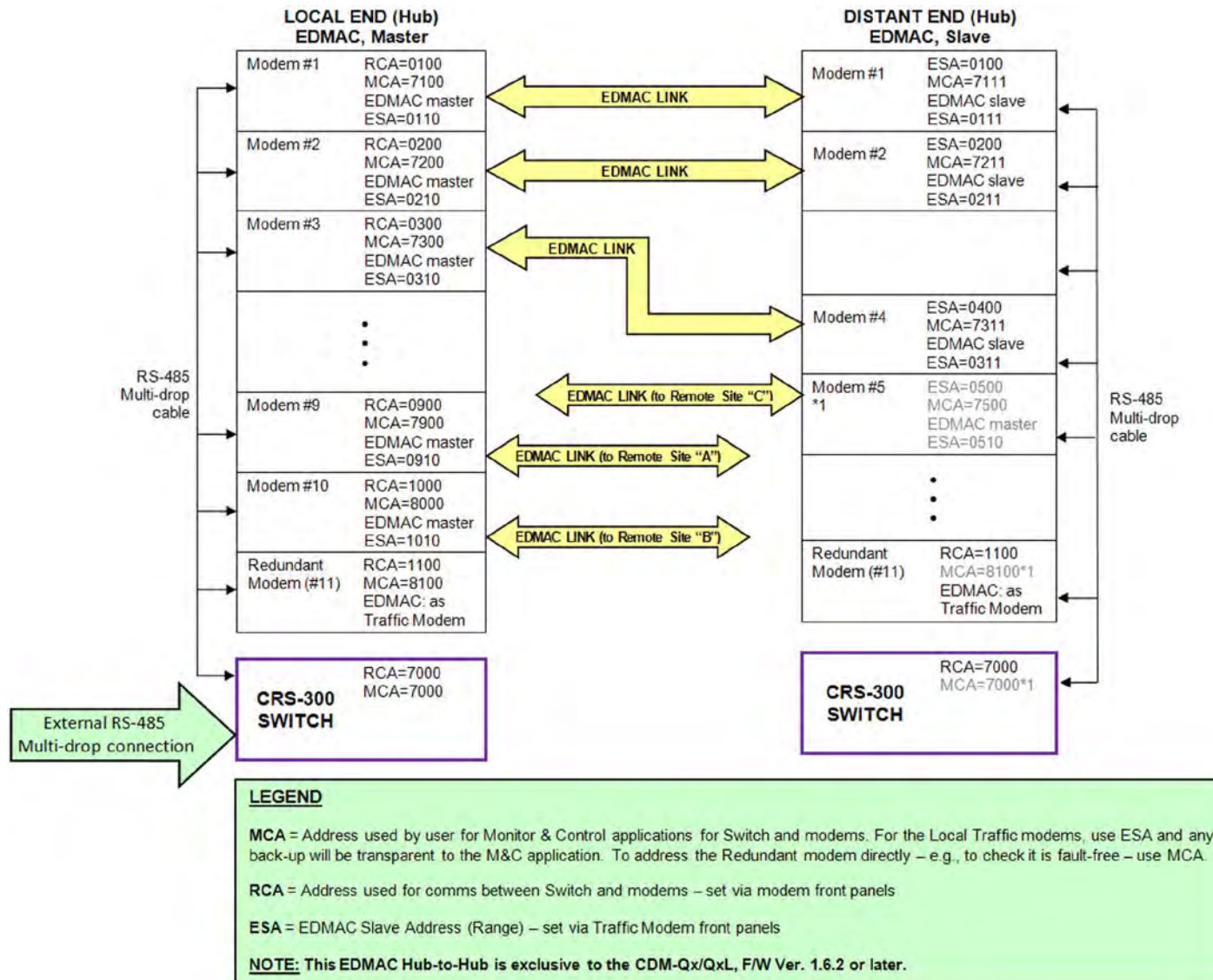


Figure C-7. CRS-300 Addressing Scheme Example: External EIA-485 with CDM-Qx/QxL Modems, EDMAC Hub-to-Hub

BLANK PAGE

## C.2 Modem Setup

- **Local Modem  $m$** , where  $m$  is modem position number (1 through 10) on Switch:
  - MCA = (Switch RCA) + (100 x  $m$ )
  - Set EDMAC Framing on.
  - Set as EDMAC master.
  - Set with EDMAC Slave Address Range, ESA = (Modem RCA) + 10
- **Distant Modem 1** (attached to the Distant end of link to Modem  $m$ ):
  - Remote control address: no setting required (Remote control not used).
  - Set EDMAC Framing on.
  - Set as an EDMAC slave.
  - Set Slave Address, ESA = (Master ESA) + 1
  - MCA = ESA
- **Two Distant Modems** in a 1:1 configuration:

Set up the on-line modem as for Distant Modem 1, described previously in this section. The offline modem is automatically configured to match the on-line modem. M&C can only be achieved to the online modem.

**Note:** It is not possible for the offline modem of a 1:1 pair to respond to EDMAC messages directly as it is not transmitting. Using the internal 1:1 link, the online modem polls and retains the off-line modem status. Depending on the modem, this information can be obtained as follows:

### 1) For CDM-625/A, CDM-570/A, CDM-570L/AL, and CDM-600/L modems:

Use **OUS (Offline Unit Status) – OUS?** for queries. This command/query is available in the following modems/firmware versions:

Modem	FW Version
CDM-625A	1.1.1 or later
CDM-625	1.1.1 or later
CDM-570A	1.1.1 or later
CDM-570AL	1.1.1 or later

Modem	FW Version
CDM-570	1.4.1 or later
CDM-570L	1.3.1 or later
CDM-600	1.6.1 or later
CDM-600L	1.3.0 or later

## 2) For CDM-Qx/QxL modems:

Use **FLT (Faults and Status) – FLT?** for queries. This command/query is available in available in firmware versions 1.6.2 or later.

**Note:** 1:1 internal redundancy in EDMAC Slave mode is available only in firmware version 1.6.2 or later.

See the appropriate modem's *Installation and Operation Manual* for additional information.

---

## C.3 Transceiver Setup



Configure the modems first for EDMAC operation, setting up the Remote Control Address (RCA) for local units, and ESA (EDMAC addresses) for EDMAC modems. A transceiver's address will be set automatically by its controlling modem if connected via the FSK link when the ODU Enable is configured.

- **Local Transceiver 1** (linked to Modem *m* on the Switch):
  - First, set up the modem RCA, as described in Section C.2.
  - On the modem, key to **Enable ODU**.

The modem automatically sets the transceiver address:

$$\text{Transceiver MCA} = (\text{Modem RCA}) + 1.$$

- **Local Transceivers 1 & 2** (1:1 configuration, attached to Modem *m* on the Switch):
  - First, set up the modem RCA, as described in Section C.2.
  - On the online modem, key to **Enable ODU**.

The modem automatically sets the transceiver addresses:

$$\text{MCA of Transceiver \#1} = (\text{Modem RCA}) + 1$$

$$\text{MCA of Transceiver \#2} = (\text{Modem RCA}) + 2$$

- **Distant Transceiver 1** (standalone):
  - First, set up the modems, first, as described earlier in this section. .
  - On the modem, key to **Enable ODU**.



The modem automatically sets the transceiver address:

$$\text{Transceiver MCA} = (\text{Master ESA}) + 4 = (\text{Slave ESA}) + 3$$

- **Distant Transceivers 1 & 2** (1:1 configuration):
  - First, set up the modem, as described earlier in this section.
  - On the modem, key to **Enable ODU**.

The modem automatically sets the transceiver addresses:

$$\text{MCA of Transceiver \#1} = (\text{Master ESA}) + 4$$

$$\text{MCA of Transceiver \#2} = (\text{Master ESA}) + 5$$

---

## C.4 M&C Applications

The system is set up such that it may be communicated to by an M&C application, e.g., SatMac or CMCS. In the SatMac application, go to the **Link Edit Mode** screen to enter the Monitor & Control Addresses (MCA).







---

2114 WEST 7TH STREET TEMPE ARIZONA 85281 USA  
480 • 333 • 2200 PHONE  
480 • 333 • 2161 FAX