



RCS11

1:1 Redundancy Switch Installation and Operation Manual

Comtech EF Data is an
AS9100 Rev B / ISO9001:2000
Registered Company



IMPORTANT NOTE: The information contained in this document supersedes all previously published information regarding this product. This manual is subject to change without prior notice.



Errata A

Comtech EF Data Documentation Update

Subject: Changes to Chapter 4. Connection Hardware for Tables 4-3, 4-4, 4-5
Alarm Fault Cable name.

Date: July 9, 2010

Original Manual Part Number: MN-RCS11 **Rev 9**

Errata Number / Agile Document ID ER-RCS11-EA9 **Agile CO Number** C12397

Change Specifics:

This information will be incorporated into the next revision. **Replace the following pages with the pages below. Pages 4-6, 4-7, 4-8 in the MN-RCS11 manual.**

DMD20, DMD50 or DMD2050 with HSSI Interface

Figure 4-3 illustrates a 1:1 system using a RCS11 with the universal Interface connected to DMD20 or DMD50 Modems with 70/140 MHz option and G.703/HSSI Interfaces. Table 4-3 describes the connection hardware required.

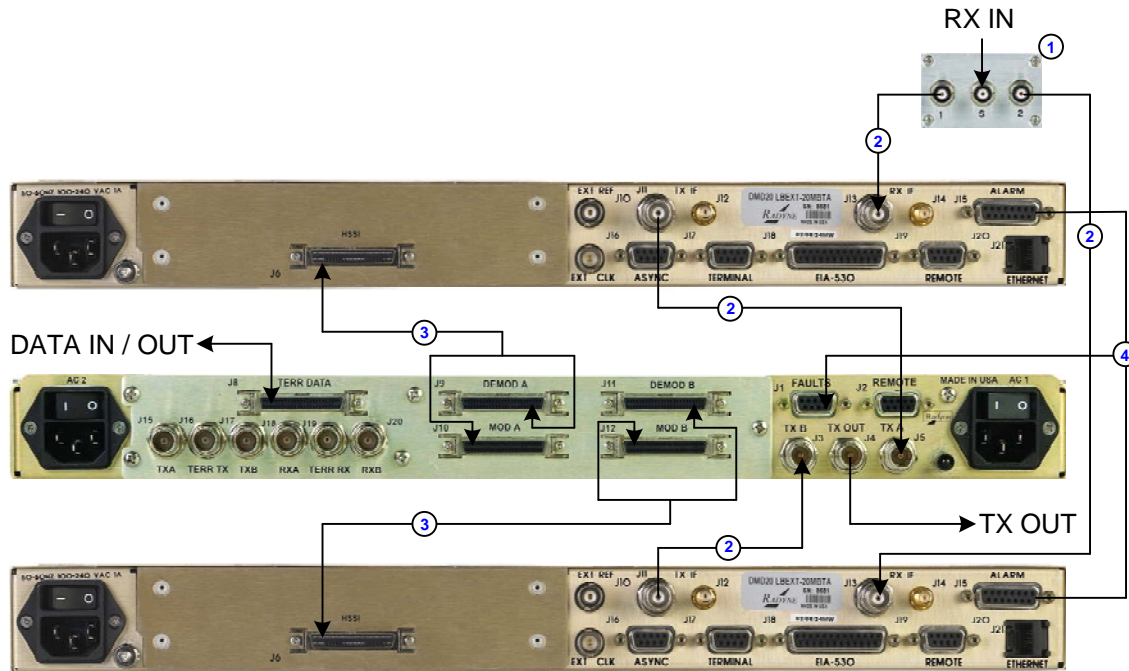

Figure 4-3. RCS11 with HSSI G.703 Interface Connected to DMD20, DMD50 or DMD2050 Modems with G.703 HSSI Interfaces

Table 4-3. Connection Hardware for 70/140 MHz Option			
Item No.	Quantity	Part Number	Discription
1	1	RF/ZSC-2-175	70/140 IF Splitter
2	4	CA/3598-36	3' BNC to BNC 75 Ohm Coaxial Cable
3	2	CA/4181	HSSI Data Cable
4	1	CA/5162	Alarm Fault Cable

DMD20, DMD50 or DMD2050 ASI / DVB with RCS11 ASI HSSI

Figure 4-4 illustrates a 1:1 system using a RCS11 with the HSSI / ASI Interface connected to DMD20 or DMD50 Modems with 70/140 MHz option utilizing the ASI DVB data Interfaces. Table 4-4 describes the connection hardware required.

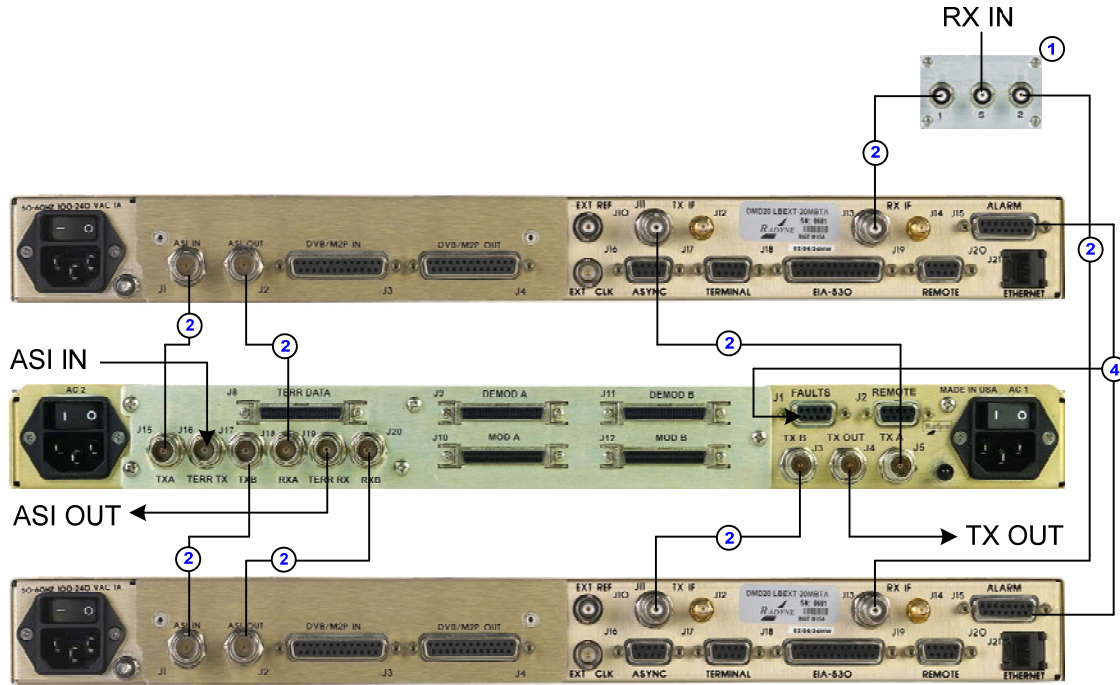

Figure 4-4. RCS11 with HSSI ASI Interface Connected to DMD20, DMD50 or DMD2050 Modems with ASI/DVB Interfaces

Table 4-4. Connection Hardware			
Item No.	Quantity	Part Number	Discription
1	1	RF/ZSC-2-175	70/140 IF Splitter
2	8	CA/3598-36	3' BNC to BNC 75 Ohm Coaxial Cable
3	1	CA/5162	Alarm Fault Cable

DMD20 HSSI

Figure 4-5 illustrates a 1:1 system using a RCS11 with the HSSI / ASI Interface connected to DMD20 Modems with HSSI Interfaces. Table 4-5 describes the connection hardware required.

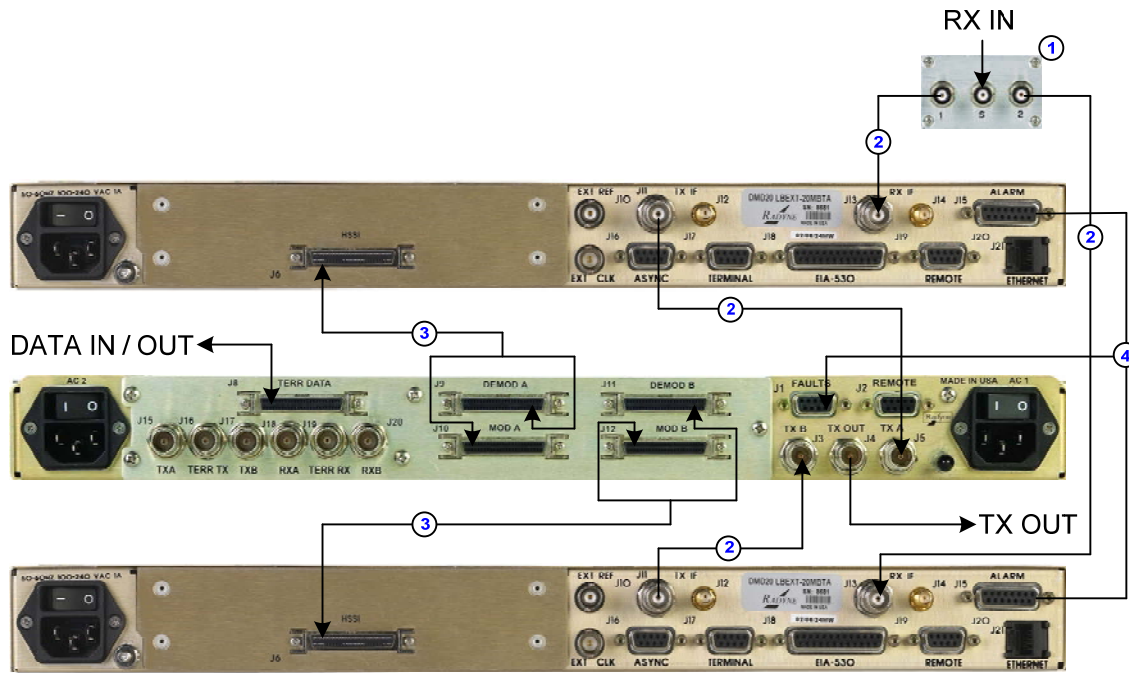

Figure 4-5. RCS11 with HSSI/ASI Interface Connected to DMD20 Modems with HSSI Interfaces

Table 4-5. Connection Hardware			
Item No.	Quantity	Part Number	Discription
1	1	RF/ZSC-2-175	70/140 IF Splitter
2	4	CA/3598-36	3' BNC to BNC 75 Ohm Coaxial Cable
3	2	CA/4181	HSSI Data Cable
4	1	CA/5162	Alarm Fault Cable



1:1 Redundancy Switch Installation and Operation Manual

Comtech EF Data is an
AS9100 Rev B / ISO9001:2000
Registered Company



Part Number MN-RCS11
Revision 9
September 29, 2009

This page is intentionally blank.

Table of Contents

TABLE OF CONTENTS	III
CHAPTER 1. INTRODUCTION	1-1
1.1 Description.....	1-1
1.2 Redundant Power Supplies	1-1
1.3 Front Panel Controls	1-1
1.4 Power-Up Defaults	1-2
CHAPTER 2. THEORY OF OPERATION	2-1
2.1 Theory of Operation	2-1
2.2 RCS11 Operation	2-1
2.2.1 Operating Procedures	2-1
2.2.2 Configuring the RCS11 (Refer to Figure 2-1)	2-2
2.2.3 Manual Mode	2-2
2.2.4 Auto Mode	2-2
2.2.5 Power-Up Defaults.....	2-2
2.3 RCS11 Major Assemblies.....	2-2
2.3.1 Main Switch Board	2-3
2.3.2 Front Panel Board	2-3
2.3.3 Redundant Power Supplies	2-3
2.4 RCS11 General Operation	2-3
2.4.1 Signals.....	2-3
2.4.2 Backup	2-3
2.4.3 Fail-Safe.....	2-4
2.4.4 Fault Relays	2-4
CHAPTER 3. USER INTERFACES.....	3-1
3.1 User Interfaces	3-1
3.2 Front Panel Interface.....	3-1
3.3 Rear Panel Interface	3-2
3.3.1 System Installation and Connections	3-2
3.3.1.1 RCS11 with Universal G.703 Interface	3-2

3.3.1.2	ASI Interface with Optional Offline IF Monitor	3-3
3.3.1.3	RCS11 Parallel Interface.....	3-5
3.3.1.4	G.703 – HSSI Interface with G.703 or ASI E3/T3/DS3/STS1	3-6
3.3.1.5	Ethernet Interface.....	3-7
3.3.1.6	T3/E3/STS1 Interface	3-8
3.3.1.7	Serial Interface	3-9
CHAPTER 4.	INSTALLATION	4-1
4.1	Installation Requirements	4-1
4.2	Unpacking.....	4-2
4.2.1	Test Data Sheet	4-2
4.3	Site Considerations	4-2
4.3.1	Power Sources.....	4-2
4.4	Rack Mounting.....	4-3
4.5	System Connections	4-3
4.6	Connections	4-4
4.6.1	DMD15 Universal.....	4-4
4.6.2	DMD20 or DMD50 Universal with G.703 IBS/IDR Interface	4-5
4.6.3	DMD20 or DMD50 with HSSI Interface.....	4-6
4.6.4	DMD20 or DMD50 ASI / DVB with RCS11 ASI HSSI.....	4-7
4.6.5	DMD20 HSSI.....	4-8
4.6.6	DMD20/DMD50 ETHERNET	4-9
4.6.7	DMD50 T3 E3 STS1.....	4-10
4.6.8	DM240 PIIC ASI Interface	4-11
4.6.9	DM240XR ASI Data Interface	4-12
4.6.10	DD240XR Ethernet.....	4-13
4.6.11	DM240XR Ethernet	4-14
4.6.12	DM240XR HSSI.....	4-15
4.6.13	DM240XR DVB Parallel.....	4-16
4.6.14	DD240XR HSSI.....	4-17
4.6.15	DM240XR & DD240XR	4-18
4.6.16	DMD20 (RS530) to RCS11 RS449/422 Serial Data Interface	4-19
4.6.17	DMD20LBST (RS530) to RCS11 RS449/422 Serial Data Interface	4-20
CHAPTER 5.	CONNECTOR PINOUTS.....	5-1
5.1	RCS11 Connections	5-1
5.2	AC Power Input/Switch.....	5-1
5.3	DC Power Input/Switch.....	5-1
5.4	RCS11 COMMON CONNECTIONS	5-2

5.4.1	FAULTS (J1)	5-2
5.4.2	REMOTE (J2)	5-2
5.4.3	TX B (J3)	5-3
5.4.4	TX OUT (J4)	5-3
5.4.5	TX A (J5)	5-3
5.4.6	GND	5-3
5.5	UNIVERSAL G.703/SYNCHRONOUS INTERFACE	5-3
5.5.1	SYNC DATA (J7)	5-3
5.5.2	MODEM A & B (J7 & J11) G703/RS422 Serial Universal Interface w/SCSI connectors	5-4
5.5.3	ESC 8K DATA (J15)	5-6
5.5.4	ESC VOICE (J16)	5-7
5.5.5	ESC Alarms (J17)	5-7
5.5.6	ES/ES (J18) Universal Interface	5-8
5.5.7	G.703 Balanced (J20)	5-8
5.5.8	SD (DDI) (J23)	5-9
5.5.9	DDO (J24)	5-9
5.5.10	IDI (J25)	5-9
5.5.11	RD (IDO) (J26)	5-9
5.6	ASI Data Interface	5-9
5.6.1	DATA A (J7)	5-9
5.6.2	ASI TERR (J10)	5-9
5.6.3	DATA B (J11)	5-9
5.6.4	Alarm A (J18)	5-9
5.6.5	Alarm B (J19)	5-10
5.7	DVB Parallel Interfaces	5-10
5.7.1	Data A & Data B DVB Parallel Interface (J7)	5-10
5.7.1.1	Data A & Data B M2P Parallel Interface (J7 & J11)	5-11
5.7.2	Terrestrial Data (J10) DVB Parallel Interface	5-12
5.7.2.1	Terrestrial Data (J10) M2P Data Interface	5-13
5.7.3	Alarm A (J18)	5-14
5.7.4	Alarm B (J19)	5-14
5.8	DMD50 UNIVERSAL G703 T3/E3 & RS422 SERIAL INTERFACE w/SCSI	5-14
5.8.1	EIA 530 (J36)	5-14
5.8.2	MODEM A & B (J7 & J11) Universal Interface, G703/Synchronous Data w/SCSI connectors	5-15
5.8.3	ESC 8K DATA (J15)	5-17
5.8.4	ESC VOICE (J16)	5-17
5.8.5	ESC Alarms (J17)	5-18
5.8.6	ES/ES (J18) Universal Interface	5-19
5.8.7	RXB (J30)	5-19
5.8.8	TERR RX (J31)	5-19
5.8.9	RXA (J32)	5-19
5.8.10	TXB (J33)	5-19
5.8.11	TERR TX (J34)	5-19
5.8.12	TXA (J35)	5-19

5.9	High-Speed Serial Interface (HSSI) & ASI or G703 Interface (Optional)	5-20
5.9.1	HSSI TERR DATA (J8)	5-20
5.9.2	ASI or G703 Data Interface	5-20
5.9.2.1	TXA ASI or G703 (J15).....	5-20
5.9.2.2	TERR TX ASI or G703 (J16)	5-20
5.9.2.3	TXB - ASI or G703 (J17)	5-21
5.9.2.4	RXA - ASI or G703 (J18)	5-21
5.9.2.5	TERR RX - ASI or G703 (J19).....	5-21
5.9.2.6	RXB - ASI or G.703 (J20)	5-21
5.9.3	FAULTS (J1)	5-21
5.10	ETHERNET & RS530 DATA INTERFACE	5-22
5.10.1	EIA 530 (J10).....	5-22
5.10.2	Ethernet Interface.....	5-23
5.10.2.1	DATA B (J27).....	5-23
5.10.2.2	TERR DATA (J28)	5-23
5.10.2.3	DATA A (J29)	5-23
5.10.2.4	SWITCH (S1)	5-23
5.11	SERIAL INTERFACE	5-23
5.11.1	TERRESTRIAL RS449/RS422 SERIAL DATA (J10).....	5-24
5.11.2	DATA A & B (J7 & J11).....	5-25
CHAPTER 6.	MAINTENANCE AND TROUBLESHOOTING	6-1
6.1	Basic Troubleshooting and Maintenance	6-1
6.2	Basic User Checks	6-1
6.2.1	Checking the Fuses	6-1
6.2.2	Checking the Cabling and Connectors	6-2
6.3	Major and Minor Faults	6-2
CHAPTER 7.	TECHNICAL SPECIFICATIONS	7-1
7.1	Introduction	7-1
7.2	General	7-1
7.3	Monitor and Control	7-1
7.4	Terrestrial Interfaces	7-1
7.5	Front Panel LED Indicators	7-2
7.6	Front Panel Controls	7-2
7.7	Power and Environmental	7-2

7.8	Storage Temperature: -20 to 70°C, 99% Humidity, Noncondensing Physical.....	7-2
APPENDIX A.	RCS11 DIP SWITCH CONFIGURATION.....	A-1
APPENDIX B.	RCS11 REMOTE COMMUNICATIONS.....	B-1
B.1	Host Computer Remote Communications.....	B-1
B.1.1	Protocol Structure	B-1
B.1.2	Protocol Wrapper	B-2
B.1.3	Frame Description and Bus Handshaking.....	B-3
B.1.4	Global Response Operational Codes.....	B-4
B.1.5	Software Compatibility	B-5
B.1.6	RLLP Summary	B-5
B.2	Remote Port Packet Structure:.....	B-6
APPENDIX C.	TERMINAL COMMUNICATIONS	C-1

Notes:

PREFACE

About this Manual

This manual describes the installation and operation for the Radyne RCS11. This is a technical document intended for earth station engineers, technicians, and operators responsible for the operation and maintenance of the RCS11.

Reporting Comments or Suggestions Concerning this Manual

Comments and suggestions regarding the content and design of this manual are appreciated. To submit comments, please contact the Comtech EF Data Technical Publications department:

TechnicalPublications@comtechefdata.com

Conventions and References

Related Documents

The following documents are referenced in this manual:

- MN-DMD20-20LBST
- MN-DMD2050
- MN-DMD50
- MN-DM240XR
- MN-DD240XR
- MN-DD2401

Metric Conversion

Metric conversion information is located on the inside back cover of this manual. This information is provided to assist the operator in cross-referencing non-Metric to Metric conversions.

Cautions and Warnings



IMPORTANT or **NOTE** indicates a statement associated with the task being performed or information critical for proper equipment function.



CAUTION indicates a hazardous situation that, if not avoided, may result in minor or moderate injury. **CAUTION** may also be used to indicate other unsafe practices or risks of property damage.



WARNING indicates a potentially hazardous situation that, if not avoided, could result in death or serious injury.

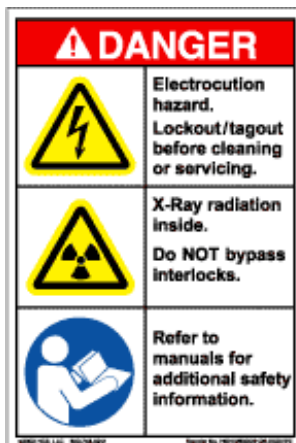

Examples of
Multi-Hazard Formats

Trademarks

Product names mentioned in this manual may be trademarks or registered trademarks of their respective companies and are hereby acknowledged.

Safety Compliance

EN 60950

Applicable testing is routinely performed as a condition of manufacturing on all units to ensure compliance with safety requirements of EN60950. This equipment meets the Safety of Information Technology Equipment specification as defined in EN60950.



Low Voltage Directive (LVD)

The following information is applicable for the European Low Voltage Directive (EN60950):

<HAR>	Type of power cord required for use in the European Community.
	CAUTION: Double-pole/Neutral Fusing ACHTUNG: Zweipolige bzw. Neutralleiter-Sicherung

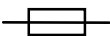
International Symbols:

Symbol	Definition
	Alternating Current
	Fuse

Symbol	Definition
	Protective Earth / Safety Ground
	Chassis Ground



For additional symbols, refer to Cautions and Warnings, listed earlier in this Preface.

Warranty Policy

Comtech EF Data products are warranted against defects in material and workmanship for a period of two years from the date of shipment. During the warranty period, Comtech EF Data will, at its option, repair or replace products that prove to be defective. Repairs are warranted for the remainder of the original two year warranty, or a 90 day extended warranty, whichever is longer.

For equipment under warranty, the owner is responsible for freight to Comtech EF Data and all related customs, taxes, tariffs, insurance, etc. Comtech EF Data is responsible for the freight charges only for return of the equipment from the factory to the owner. Comtech EF Data will return the equipment by the same method (i.e., Air, Express, Surface) as the equipment was sent to Comtech EF Data.

All equipment returned for warranty repair must have a valid RMA number issued prior to return and be marked clearly on the return packaging. Comtech EF Data strongly recommends all equipment be returned in its original packaging.

Comtech EF Data Corporation's obligations under this warranty are limited to repair or replacement of failed parts, and the return shipment to the buyer of the repaired or replaced parts.

Limitations of Warranty

The warranty does not apply to any part of a product that has been installed, altered, repaired, or misused in any way that, in the opinion of Comtech EF Data Corporation, would affect the reliability or detracts from the performance of any part of the product, or is damaged as the result of use in a way or with equipment that had not been previously approved by Comtech EF Data Corporation.

The warranty does not apply to any product or parts thereof where the serial number or the serial number of any of its parts has been altered, defaced, or removed.

The warranty does not cover damage or loss incurred in transportation of the product.

The warranty does not cover replacement or repair necessitated by loss or damage from any cause beyond the control of Comtech EF Data Corporation, such as lightning or other natural and weather related events or wartime environments.

The warranty does not cover any labor involved in the removal and or reinstallation of warranted equipment or parts on site, or any labor required to diagnose the necessity for repair or replacement.

The warranty excludes any responsibility by Comtech EF Data Corporation for incidental or consequential damages arising from the use of the equipment or products, or for any inability to use them either separate from or in combination with any other equipment or products.

A fixed charge established for each product will be imposed for all equipment returned for warranty repair where Comtech EF Data Corporation cannot identify the cause of the reported failure.

Exclusive Remedies

Comtech EF Data Corporation's warranty, as stated is in lieu of all other warranties, expressed, implied, or statutory, including those of merchantability and fitness for a particular purpose. The buyer shall pass on to any purchaser, lessee, or other user of Comtech EF Data Corporation's products, the aforementioned warranty, and shall indemnify and hold harmless Comtech EF Data Corporation from any claims or liability of such purchaser, lessee, or user based upon allegations that the buyer, its agents, or employees have made additional warranties or representations as to product preference or use.

The remedies provided herein are the buyer's sole and exclusive remedies. Comtech EF Data shall not be liable for any direct, indirect, special, incidental, or consequential damages, whether based on contract, tort, or any other legal theory.

Customer Support

Contact the Comtech EF Data Customer Support Department for:

- Product support or training
- Reporting comments or suggestions concerning manuals
- Information on upgrading or returning a product

A Customer Support representative may be reached at:

Comtech EF Data
Attention: Customer Support Department
2114 West 7th Street
Tempe, Arizona 85281 USA
480.333.2200 (Main Comtech EF Data number)
480.333.4357 (Customer Support Desk)
480.333.2161 FAX

To return a Comtech EF Data product (in-warranty and out-of-warranty) for repair or replacement:

- **Contact** the Comtech EF Data Customer Support Department. Be prepared to supply the Customer Support representative with the model number, serial number, and a description of the problem.
- **Request** a Return Material Authorization (RMA) number from the Comtech EF Data Customer Support representative.
- **Pack** the product in its original shipping carton/packaging to ensure that the product is not damaged during shipping.
- **Ship** the product back to Comtech EF Data. (Shipping charges should be prepaid.)

Online Customer Support

An **RMA number request** can be requested electronically by contacting the Customer Support Department through the online support page at **www.comtechefdata.com/support.asp**:

- **Click** on the “Service” hyperlink, then read the “Return Material Authorization” section for detailed instructions on our return procedures.
- **Click** on the “RMA Request Form” hyperlink, then fill out the form completely before sending.
- **Send e-mail** to the Customer Support Department at **service@comtechefdata.com**.

For information regarding this product’s warranty policy, refer to the Warranty Policy, p. xxii.

Chapter 1. INTRODUCTION

1.1 Description

The Radyne RCS11 1:1 Redundancy Switch provides simple backup redundancy protection for most configurations of the DMD15, DMD20, DMD50 and DMD2050 Satellite Modems as well as the DM240XR Video Modulator and DD240XR Video Demodulator. The backup functions of the RCS11 may be performed manually via the front panel or from the Terminal Mode. Refer to Figure 1-1 for an illustration of the RCS11 1:1 Redundancy Switch Front Panel, Figure 1-2 for the Interface options of the RCS11 and Figure 1-3 of a RCS11 Functional Block Diagram.

The RCS11 redundant 1:1 switch supports various product configurations that require different setups. The switch can support a modem, modulator or demodulator only applications.

Operating in the Automatic Mode, the RCS11 immediately places a Backup Modem online in the event of a Primary Online Modem failure. In the Manual Mode, the user may designate the selected Online Primary Modem from either the Interactive Front Panel or a remote Terminal Interface.



Figure 1-1. RCS11 1:1 Redundancy Switch Front Panel

1.2 Redundant Power Supplies

The RCS11 is equipped with two fully redundant internal power. Each power supply is fully independent of the other, including their source of AC power and fusing. The RCS11 remains fully operational as long as either power supply is providing a source of power. The power supplies are located one on either side of the front of the RCS11 Chassis.

1.3 Front Panel Controls

The Front Panel of the RCS11 provides all of the necessary controls and LED indicators to provide the operator with online status and backup status of the online and backup Modulators and deModulators.

1.4 Power-Up Defaults

During power-up, the RCS11 initializes itself to the last mode set by the Front Panel Pushbuttons. For example, if the operator desires the RCS11 to operate in the Auto Mode, with both the Modulator and Demodulator set to Modem B, the operator places the RCS11 into this condition using the Front Panel Pushbuttons and the RCS11 stores this configuration into nonvolatile memory. If the power source was then to fail and be restored, the RCS11 would again power-up in the Auto Mode with both the Modulator and Demodulator set to Modem B.



Universal with G.703 IBS/IDR Interface w/ 70/140 IF TX (used with DMD15/20/50)



Universal with G.703 IBS/IDR Interface w/L-Band IF (used with DMD15/20/50)

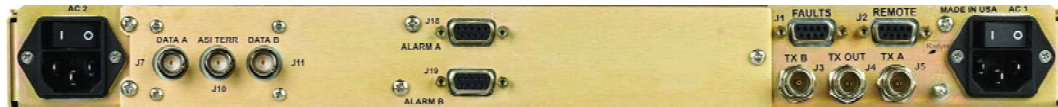

ASI Interface w/ 70/140 IF TX or RX only option (used with DM240XR or DD240XR)

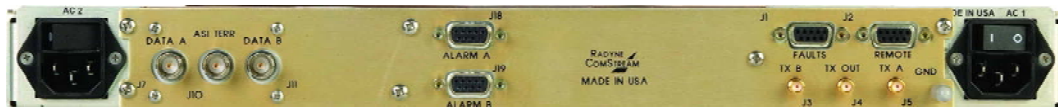

ASI Interface w/ L-Band IF TX or RX only options (used with DM240XR or DD240XR)

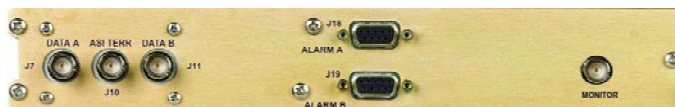

Optional ASI Interface with Offline 70/140 IF Monitor (used with DM240XR)



Optional Parallel Interface (used with DM240XR or DD240XR)

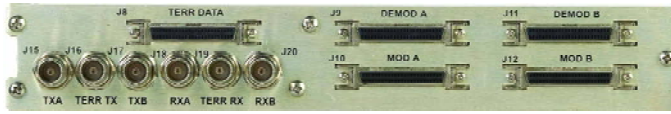

Optional HSSI and G703 or ASI Interface used with DM240XR, DD240XR, DMD20, DMD50

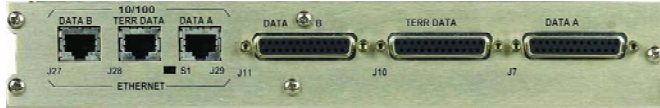

Optional Ethernet Interface (used with DM240XR, DD240XR, DMD20/50)



Optional T3/E3 Interface (used with DMD50 only)



Optional RS449/RS422 Serial interface

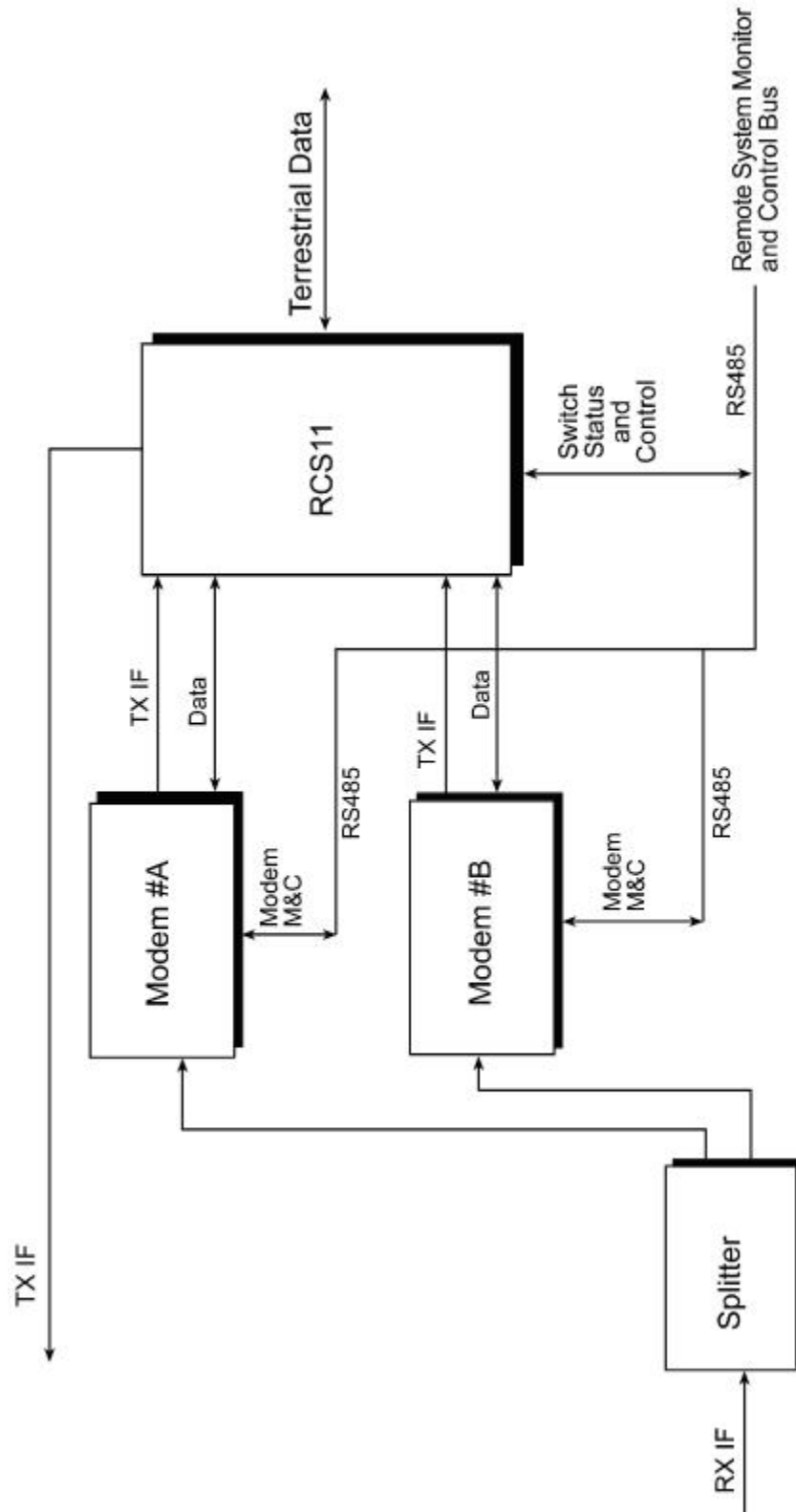

Figure 1-3. RCS11 Functional Block Diagram

Chapter 2. Theory of Operation

2.1 Theory of Operation

2.2 RCS11 Operation

A block diagram of the signal flow is shown in Figure 2-1 below.

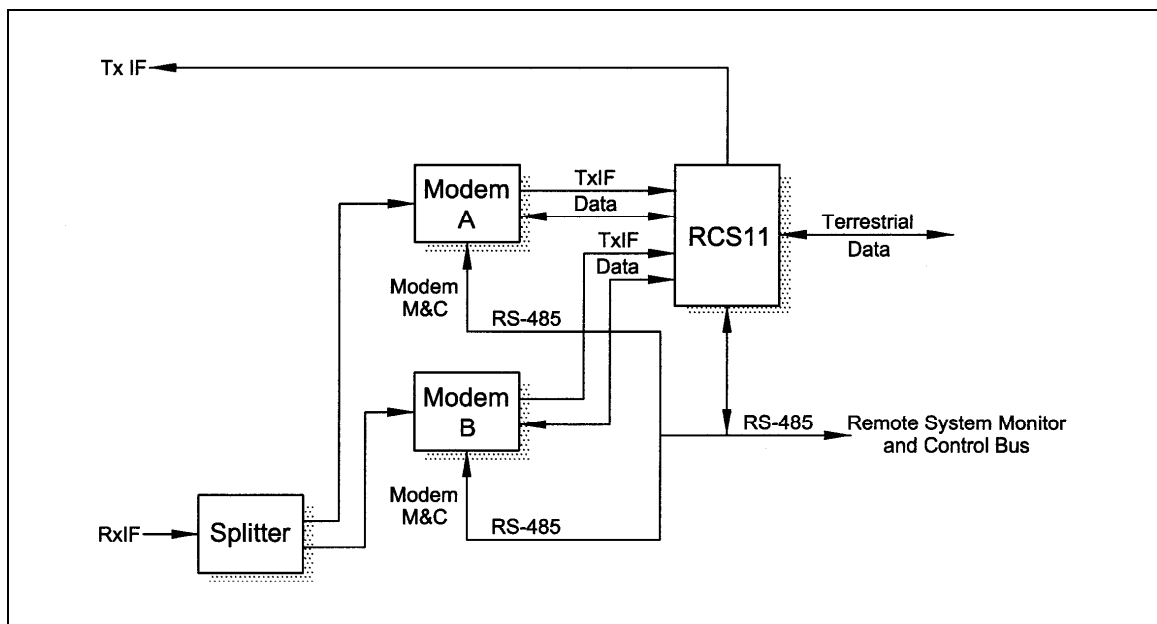

Figure 2-1. Functional Block Diagram

2.2.1 Operating Procedures

The RCS11 is designed to require minimal operator intervention and control during normal operation. After initial setup, the unit should operate in a relatively 'transparent' manner, providing trouble-free backup of the online Modems. The scope of this section is limited to instruction on the various modes of control available to the operator. Refer to Section 3-1 for the RCS11 Front Panel Controls and Indicators and Table 3-1 for a description of the Controls and Indicators.

2.2.2 Configuring the RCS11 (Refer to Figure 2-1)

The purpose of the 'ENABLE' pushbutton on the front panel is to reduce the risk of accidentally changing the operating modes of the RCS11 by accidentally bumping any one of the front panel pushbuttons. For any one of the front panel pushbuttons to function, the 'ENABLE' pushbutton must be depressed simultaneously with the desired function pushbutton.

Depress the 'ENABLE' pushbutton. This pushbutton must be depressed to allow the operator to proceed with any other configurations. The 'MANUAL' LED should illuminate and the FAULT indicator may momentarily flash. Under the MOD region of the front panel, depress 'SELECT A' to bring Modem 'A' modulator online. The green LED should illuminate. Under the DEMOD region of the front panel, depress 'SELECT A' to bring modem 'A' demodulator online. The Green LED should illuminate. The RCS11 should now be in backup mode with modem 'A' online.

2.2.3 Manual Mode

To manually select which MOD or DEMOD is to be placed online, simultaneously depress the 'ENABLE' pushbutton and the appropriate MOD or DEMOD 'SELECT' pushbutton. When a MOD or DEMOD selection is made, the RCS11 enters Manual Mode to carry out the selection, and will not respond to either modem's MOD or DEMOD Fault signals until placed back into Auto Mode.

2.2.4 Auto Mode

To enable automatic backup in the event of a MOD or DEMOD failure, the RCS11 must be placed into the Auto Mode. First, select which MOD and DEMOD are to be active by following the 'Manual Mode' procedure in the previous paragraph. To enter the Auto Mode, simultaneously depress the 'ENABLE' pushbutton and the 'SELECT AUTO' pushbutton. The RCS11 will then enter into Auto Mode with the last selections made in Manual Mode. In the Auto Mode, the decision to switch from one MOD or DEMOD to another is made automatically by monitoring the Fault signals from each modem.

2.2.5 Power-Up Defaults

During power-Up, the RCS11 initializes itself to the last mode set by the operator on the front panel pushbuttons. For example, if the operator desires the RCS11 to operate in the Auto Mode, with both Mod and Demod set to Modem B, by placing the RCS11 into this condition using the front panel pushbuttons, the settings are stored into non-volatile memory. If MOD B was to fail, and the RCS11 was to backup with MOD A, the new backup setting would not be saved. If the power was to be removed and restored, the RCS11 would again power-up in AUTO MODE, with both MOD and DEMOD set to Modem B.

2.3 RCS11 Major Assemblies

The RCS11 Redundancy Control Unit contains the modules that control and monitor the operation of the 1:1 Switch system. The 1:1 Switch is composed of the following major assemblies and components:

- Main Switch Board
- Front Panel Board
- Dual Redundant Power Supplies

2.3.1 Main Switch Board

The Main Switch Board contains the RCS11 1:1 Switch Intelligence and Memory Circuitry and all switching circuitry. The on-board microprocessor is an MC68HC11, which has a 16-bit address bus and an 8-bit data bus. The microprocessor controls and coordinates all of the major functions of the Switch and performs all necessary calculations. The non-volatile system memory on the board stores the switching parameter settings for each modem channel. Control and data signals are routed to the appropriate devices in the system through various latches and transceivers that are controlled by the microprocessor.

2.3.2 Front Panel Board

The Front Panel Board contains the LED Indicators and the pushbutton switches needed to control and operate the RCS11. Refer to Figure 3.0 for a description of Front Panel Indicators.

2.3.3 Redundant Power Supplies

The 1:1 Switch comes equipped with two fully redundant internal power supplies (PS1 and PS2) that supplies power to the system. Each supply is fully independent of the other, including their source of AC power and fusing.

The Switch can remain fully operational as long as it is supplied with a source of voltage from either power supply. PS1 and PS2 are located one on either side at the rear of RCS11 chassis.

2.4 RCS11 General Operation

2.4.1 Signals

All necessary Modem signals are backed-up through a passive switching system. Signals that are required to maintain the modem in off-line (hot-standby) are buffered by appropriate circuitry to minimize loading on incoming signals.

2.4.2 Backup

If an online MOD fault is sensed, and the off-line MOD is in a non-faulted state, the RCS11 will switch to the MOD without the fault. The Fault Signal has a small debounce delay to prevent false triggering. If the faulted MOD has its fault cleared, it stays off-line unless the other MOD has subsequently faulted. The DEMOD faults are handled in a similar manner, but the fault signals have longer debounce delays to allow for Demodulator acquisition time.

2.4.3 Fail-Safe

If the RCS11 has a non-recoverable internal fault, the MOD and DEMOD both revert back to Modem A, the Switch Fault LED is illuminated, and the Switch Fault Relay switches to a faulted state.

If Power Supply 1 and Power Supply 2 simultaneously fail, the switching circuitry in the RCS11 reverts back to Modem A, and the Switch Fault Relay switches to a faulted state. Modem B does not receive buffered signals in this condition.

2.4.4 Fault Relays

Fault Connector (J1), has Form-C contacts to indicate the state of the MOD and DEMOD selections. An additional Form-C contact is available to indicate an RCS11 Fault.

Chapter 3. User Interfaces

3.1 User Interfaces

There are four user Interfaces available for the RCS11. These are:

- Front Panel
- Remote Port
- Terminal



3.2 Front Panel Interface

Table 3-1. RCS11 Front Panel Controls and Indicators

Nomenclature	Description	Function
Power 1	Indicates PS1 has power applied	LED illuminates Green for Power Available
Power 2	Indicates PS2 has power applied	LED illuminates Green for Power Available
Fault	Indicates a Switch Fault has occurred	LED illuminates Red for Switch Fault
Auto (LED)	Indicates RCS11 is in the Auto Mode	LED illuminates Green for Auto Mode
Manual (LED)	Indicates the RSC11 is in the Manual Mode	LED illuminates Green for Manual Mode
ENABLE (Pushbutton)	-----	Enables Front Panel controls to function
SELECT AUTO (Pushbutton)	-----	Allows the operator to select Automatic Mode of operation
Demodulator Controls and Indicators		
Online LED	Indicates which Demodulator is online: A or B	LED illuminates green for Online
Fault LED	The RCS11 has received a Demodulator fault	LED illuminates Red for Fault

	from Modem A or B	
SELECT Demod A or B (Pushbutton)	-----	Allows the operator to select a Demodulator: A or B
Modulator Controls and Indicators		
Online LED	Indicates which Modulator is online: A or B	LED illuminates green for Online
Fault LED	The RCS11 has received a fault from Modulator A or B	LED illuminates Red for Fault
SELECT Mod A or B (Pushbutton)	-----	Allows the operator to select a Modulator: A or B

3.3 Rear Panel Interface

3.3.1 System Installation and Connections

3.3.1.1 RCS11 with Universal G.703 Interface

Figure 3-1 illustrates the RCS11 with the Universal G.703 Interface available with either AC or DC power entry and 70/140 or L-Band Intermediate Frequency. Table 3-1 describes the connection hardware required.

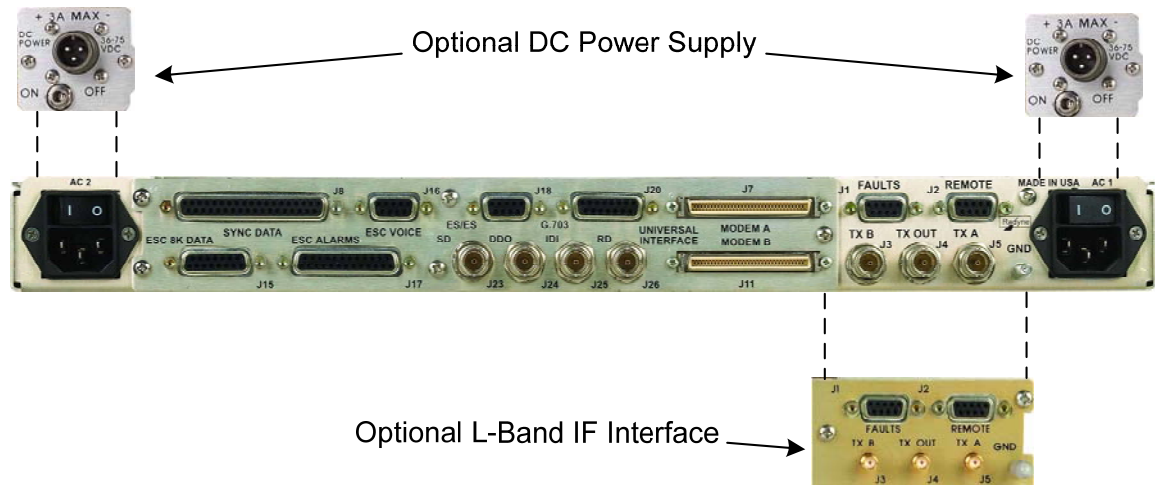

Figure 3-1. RCS11 with the Universal G.703 Interface

Table 3-1. Connection Hardware		
LOCATION	CONNECTOR	DESCRIPTION
AC1 / AC2	IEC/EN60320/C/3	Power Entry Module for Primary and Back Up AC
DC1 / DC2	MS3102A10SC-3P	Power Entry Module for Primary and Back Up DC
J1 FAULT	9-Pin F D Sub.	Switch Fault Status
J2 REMOTE	9-Pin F D Sub.	232 or 485 Communications
J3 TX B	BNC	IF Transmit Input From Primary Device
J4 TX Out	BNC	Main IF Output
J5 TX A	BNC	IF Transmit Input From Back Up Device
J7 MODEM A	SCSI	Data and Fault Primary Device
J8 SYNC DATA	37-Pin F D Sub	In and Out Synchronous Data
J11 MODEM B	SCSI	Data and Fault Back Up Device
J15 ECS 8K DATA	15-Pin F D Sub	Eng. Service Channel for Teletype
J16 ESC VOICE	9-Pin F D Sub.	Eng. Service Channel for Voice or 64K Data
J17 ESC ALARMS	25-Pin F D Sub	Eng. Service Channel for Backward Alarm Reporting
J18 ES/ES	9-Pin F D Sub.	Earth Station To Earth Station Communication
J20 G.703	15-Pin F D Sub	Balanced Asynchronous Data
J23 SD	BNC	Serial Send Data
J24 DDO	BNC	Drop Data Output
J25 IDI	BNC	Insert Data Input
J26 RD	BNC	Serial Receives Data

3.3.1.2 ASI Interface with Optional Offline IF Monitor

Figure 3-2 illustrates the RCS11 ASI Interface with the optional offline IF monitor port. This is used to monitor either the primary or back up data stream when in the offline state. The offline IF monitor port is available with the ASI Interface only. Table 3-2 describes the connection hardware required.

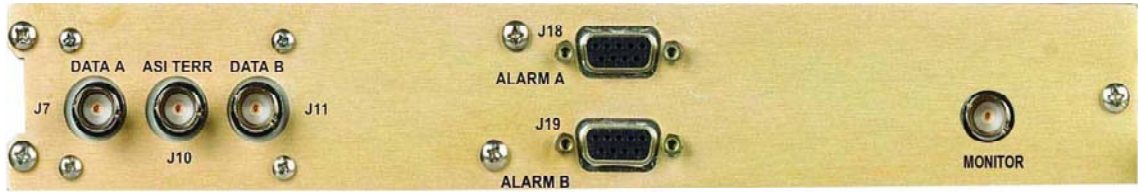

Figure 3-2. RCS11 ASI Interface for DM240XR or DD240XR

Table 3-2. Connection Hardware		
LOCATION	CONNECTOR	DESCRIPTION
J7 DATA A	BNC	Asynchronous Data from Primary Device
J10 ASI TERR	BNC	Asynchronous Data Out
J11 DATA B	BNC	Asynchronous Data from Back Up Device
J18 ALARM A	9-Pin D Sub	Alarm Fault Primary Device
J19 ALARM B	9-Pin D Sub	Alarm Fault Back Up Device
J20 MONITOR	BNC	Offline IF Monitor

3.3.1.3 RCS11 Parallel Interface

Figure 3-3 illustrates the RCS11 DVB Parallel Data Interface (RS422 and LVDS Parallel). Table 3-3 describes the connection hardware required.

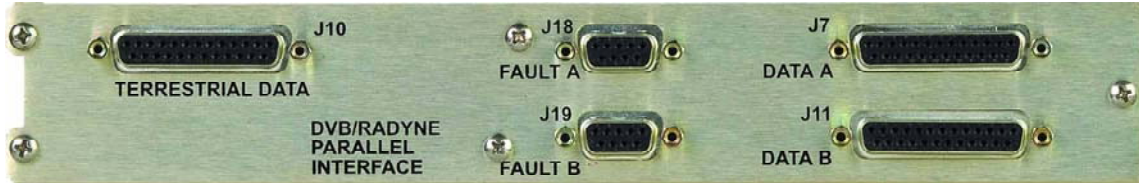

Figure 3-3: RCS11 DVB Parallel Interface (RS422 and LVDS)

Table 3-3. Connection Hardware		
LOCATION	CONNECTOR	DESCRIPTION
J7 DATA A	25-Pin F D Sub	Parallel RS422 and LVDS Data A
J10 TERRESTRIAL DATA	25-Pin F D Sub	Parallel Data Input
J11 DATA B	25-Pin F D Sub	Parallel RS422 and LVDS Data B
J18 FAULT A	9-Pin F D Sub	Alarm Fault Primary Device
J19 FAULT B	9-Pin F D Sub	Alarm Fault Back Up Device

3.3.1.4 G.703 – HSSI Interface with G.703 or ASI E3/T3/DS3/STS1

Figure 3-4 illustrates the RCS11 HSSI Interface and optional G.703 or ASI data interface. The RCS11 must be configured from the factory to support ASI or G703. The G703 rates supported are E3, T3 and STS. Table 3-4 describes the connection hardware required. (For G.703 with IDR ESC support Refer to 3.3.1.6)

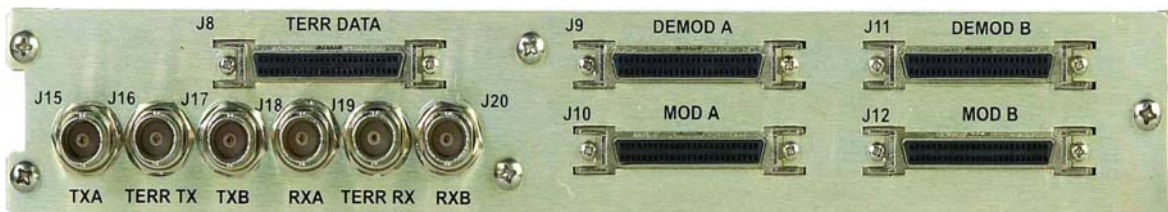
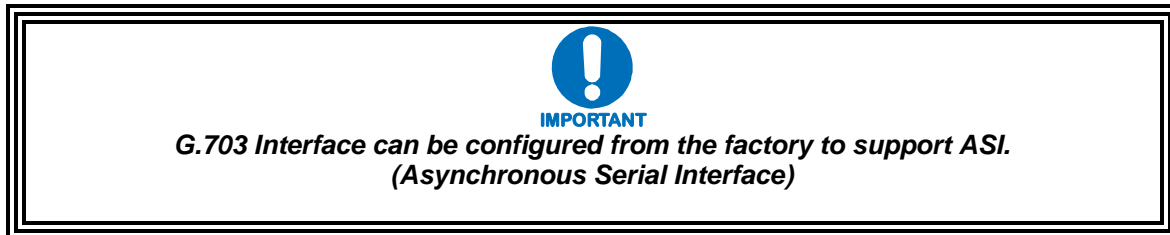

Figure 3-4. RCS11 HSSI / G.703 Interface

Table 3-4. Connection Hardware		
LOCATION	CONNECTOR	DESCRIPTION
J8 TERR DATA	HSSI	Data Input / Output
J9 DEMOD A	HSSI	Demodulator Primary
J10 MOD A	HSSI	Modulator Primary
J11 DEMOD B	HSSI	Demodulator Back Up
J12 MOD B	HSSI	Modulator Back Up
J15 TX A	BNC	G.703 T3/E3 Optional ASI Primary
J16 TERR TX	BNC	G.703 T3/E3 Optional ASI Data In
J17 TX B	BNC	G.703 T3/E3 Optional ASI Back Up
J18 RX A	BNC	G.703 T3/E3 Optional ASI Primary
J19 TERR RX	BNC	G.703 T3/E3 Optional ASI Data Out
J20 RX B	BNC	G.703 T3/E3 Optional ASI Back Up

3.3.1.5 Ethernet Interface

Figure 3-5 illustrates the RCS11 that supports 10/100/1000 Data Rates. The RCS11 Ethernet interface can be configured to support a modem or modulator/demodulator. The S1 switch must be properly set to the correct position to support the modem or Modulator/Demodulator.

Table 3-5 describes the connection hardware required.

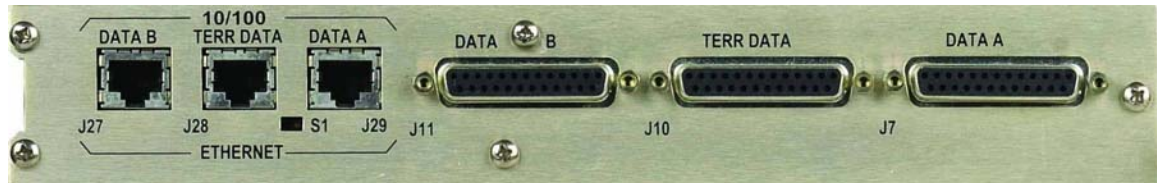

Figure 3-5. RCS11 Ethernet Interface (10/100/1000)

Table 3-5. Connection Hardware		
LOCATION	CONNECTOR	DESCRIPTION
J7 DATA A	25-Pin D Sub	EIA 530 Data Primary
J10 TERR DATA	25-Pin D Sub	EIA 530 Data Input
J11 DATA B	25-Pin D Sub	EIA 530 Data Back Up
J27 DATA B	RJ45	Ethernet Data Back Up
J28 TERR DATA	RJ45	Ethernet Data Input/Output
J29 DATA A	RJ45	Ethernet Data Primary
S1	Switch	Modem or Mod/Demod setting

NOTE: On the S1

Switch moving the switch to the left sets the unit to the Modem Feature, moving the switch to the right sets the unit to the Mod/Demod Feature.

NOTE: Power must be cycled after changing S1 to desired setting for effect to take place.

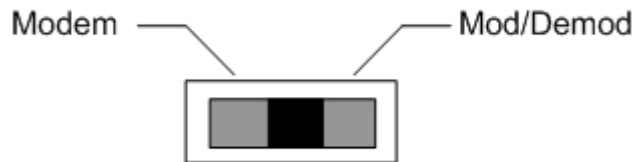

Figure 3-6. RCS11 S1 Switch Diagram

3.3.1.6 T3/E3/STS1 Interface

Figure 3-7 illustrates the RCS11 T3/E3/STS1. Table 3-6 describes the connection hardware required.



Figure 3-7. RCS11 T3 E3 STS1 Interface

Table 3-6. Connection Hardware		
LOCATION	CONNECTOR	DESCRIPTION
J7 Modem A	68-Pin High Density Female	Data and Fault Primary Device
J11 Modem B	68-Pin High Density Female	Data and Fault Backup Device
J15 ESC 8K Data	15-Pin D Sub Female	Eng. Service Channel for Teletype
J16 ESC Voice	9-Pin D Sub Female	Eng. Service Channel for Voice or 64k Data
J17 ESC Alarms	25-Pin D Sub Female	Eng. Service Channel for Backward Alarm
J18 ES/ES	9-Pin D Sub Female	Earth Station to Earth Station Communication
J30 Rx B	BNC	T3/E3 Rx Data from Backup Device
J31 Terr Rx	BNC	T3/E3 Rx Data - Out
J32 Rx A	BNC	T3/E3 Rx Data from Primary Device
J33 Tx B	BNC	T3/E3 Send Data to Backup Device
J34 Terr Tx	BNC	T3/E3 Send Data - In
J35 Tx A	BNC	T3/E3 Send Data to Primary Device
J36 EIA 530	25-Pin D Sub Female	In and Out Synchronous Data

3.3.1.7 Serial Interface

Figure 3-8 illustrates the RCS11 RS449/422 Serial Interface. Table 3-7 describes the connection hardware required.



Figure 3-8. RCS11 RS449/422 Serial Interface

Table 3-7. Connection Hardware		
LOCATION	CONNECTOR	DESCRIPTION
J7 Data A	37-Pin D Sub	Data Primary Device
J10 Terrestrial Data	37-Pin D Sub	Terrestrial Data Device
J11 Modem B	37-Pin D Sub	Data Backup Device
J18 Alarm A	9-Pin D Sub	Alarm Fault Primary Device
J19 Alarm B	9-Pin D Sub	Alarm Fault Backup Device

Notes:

Chapter 4. Installation

4.1 Installation Requirements

The RCS11 can be installed within any standard 19-inch equipment cabinet or rack, and requires 1 rack unit (RU) of mounting space (1.75 inches) vertically and 21 inches of depth. Including cabling, a minimum of 23-inches of rack depth is required.



There are no user-serviceable parts or configuration settings located inside the RCS11 Chassis. There is a potential shock hazard internally at the power supply module. DO NOT open the RCS11 Chassis under any circumstances.



Before initially applying power to the unit, it is a good idea to disconnect the transmit output from the operating ground station equipment. This is especially true if the current RCS11 configuration settings are unknown, where incorrect setting could disrupt existing communications traffic.

4.2 Unpacking

The RCS11 was carefully packaged to avoid damage and should arrive complete with the following items for proper installation:

- RCS11 1:1 Redundancy Switch Unit
- Two AC or DC Power Cords
- 1:1 Switch System Test Data Sheet
- RCS11 Interconnect Cable and Materials as required
- An Installation and Operation Manual

4.2.1 Test Data Sheet

Each RCS11 1:1 Redundancy Switch system is shipped with a Test Data Sheet. This report contains information on the results of the Switch quality control testing. The report also includes information pertaining to the system settings that were made at the factory. Radyne recommends that the user save this report for future reference.

4.3 Site Considerations

Adequate site planning and preparation simplifies the installation process and results in a more reliable system. The user should ensure that the site has adequate electrical power, environmental controls and protection against sources of electrical radiation and interference.

4.3.1 Power Sources

The power sources should be properly grounded and as free as possible from electrical interference. The RCS11 employs a dual redundant power supply configuration. Each power cord on the RCS11 must be plugged into its own separate power circuit. Each circuit must have its own independent circuit breaker.

Grounding is achieved automatically when the three-prong power plug is inserted into a power receptacle. This should be checked by testing that there is no voltage present between the chassis of the Switch and the power line ground.



The protective ground must not be bypassed with a three-prong to two-prong adapter or defeated in any way. Defeating the ground may result in operator injury or damage to the system.

4.4 Rack Mounting

To allow for the easy installation of cables and adequate air circulation through the units, a minimum of six inches of clearance must be provided at the sides and rear of the units. In addition, the RCS11 requires a minimum of 1 $\frac{3}{4}$ " (1RU) of clearance on top of the unit. If the Switch is mounted on slide mounts, the cables must be of sufficient length to allow the units to be pulled forward on the mounts.



If either AC line cord remains connected to the RCS11, dangerous AC voltages will be present within the Switch. The top cover of the RCS11 should not be removed for any reason other than fuse replacement. Refer to Section 4, Basic Maintenance and Troubleshooting.

4.5 System Connections

For initial RCS11 setup and configuration, perform the following procedure:

1. Verify that the AC Power Cords to the RCS11 and units to be connected are unplugged.
2. Interconnect the units as shown in the figures below.
3. Attach the AC Power Cords to the RCS11 and the units to be connected.
4. Using the On/Off Switches located on either side of the rear panel of the RCS11, power-up both redundant power supplies. Power 1 and Power 2 (Green) LEDs should illuminate.

If BOTH Green LEDs do not illuminate, there is a fault with one of the power supplies. Refer to Section 6, Maintenance for the appropriate action.

5. Power up the units to be connected. Their Green Power LEDs should illuminate.

If not, refer to the appropriate Installation and Operation manual for further action to be taken.

6. Proceed to Section 4, User Interface for information on the RCS11 controls and indicators.



PROPER GROUNDING PROTECTION: During installation and setup, the user must ensure that the unit is properly grounded. The equipment shall be connected to the protective earth connection through the end use protective earth protection.

In addition, the IF input and output coax cable shielding must be properly terminated to the Chassis/unit ground

4.6 Connections

This section provides data and frequency connections in a typical one for one installation.

4.6.1 DMD15 Universal

Figure 4-1 illustrates a 1:1 system using a RCS11 with the Universal Interface connected to DMD15 Modems. Table 4-1 describes the connection hardware required.

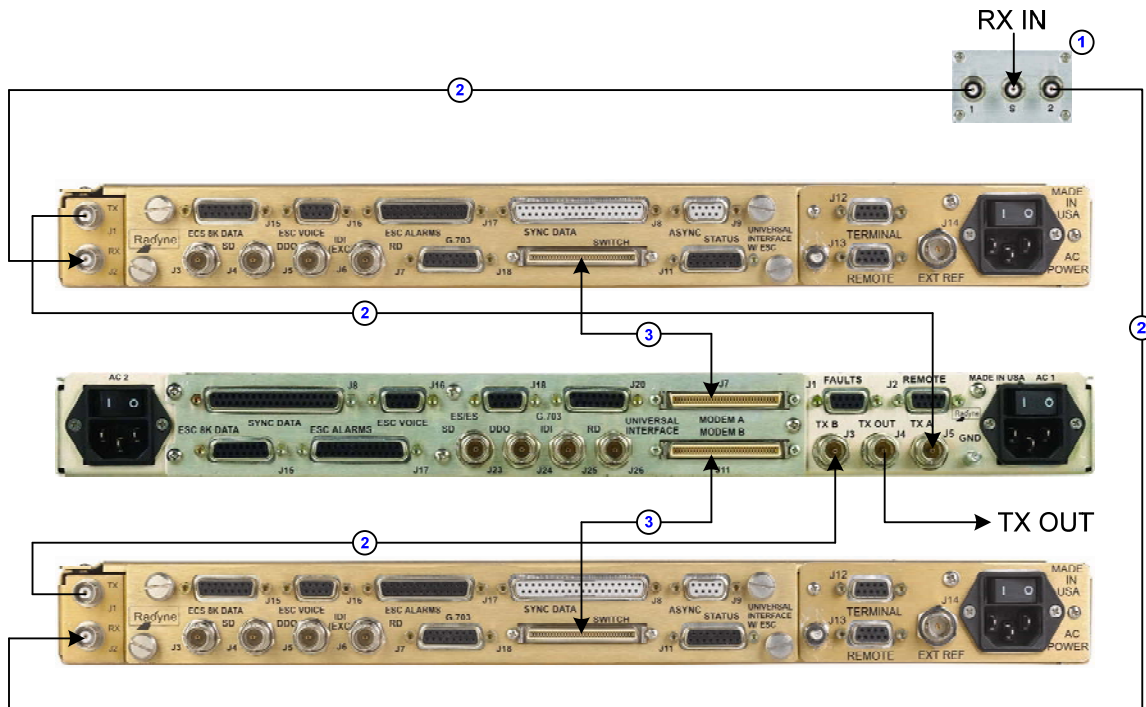

Figure 4-1. RCS11 with Universal Interface Connected To DMD15 Modems

Table 4-1. Connection Hardware			
Item No.	Quantity	Part Number	Discription
1	1	RF/ZSC-2-175	70/140 IF Splitter
2	4	CA/3598-36	3' BNC to BNC 75 Ohm Coaxial Cable
3	2	CA/3407-3	3' SCSI Data Cable

4.6.2 DMD20, DMD50 or DMD2050 Universal with G.703 IBS/IDR Interface

Figure 4-2 illustrates a 1:1 system using the RCS11 with the Universal Interface connected to DMD20 Modems with 70/140 MHz IF configuration and G.703 IBS/IDR Interfaces. Table 4-2 describes the connection hardware required.

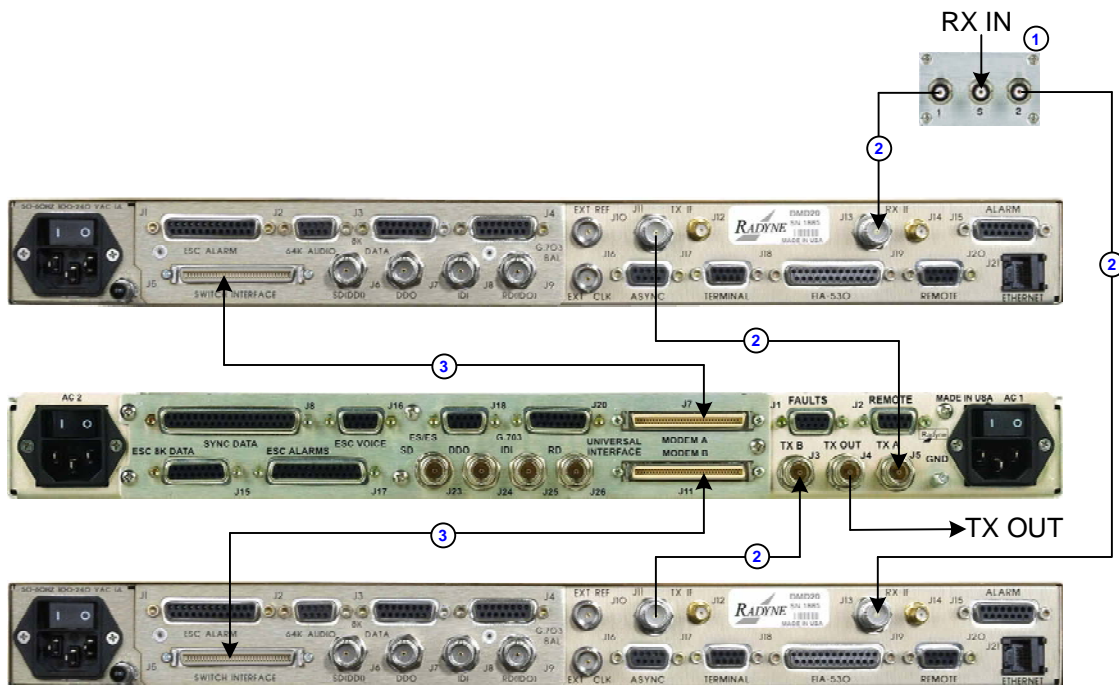

Figure 4-2. RCS11 with Universal Interface Connected to DMD20, DMD50 or DMD2050 Modems with G.703 IBS/IDR Interfaces

Table 4-2. Connection Hardware for 70/140 MHz Option			
Item No.	Quantity	Part Number	Discription
1	1	RF/ZSC-2-175	70/140 IF Splitter
2	4	CA/3598-36	3' BNC to BNC 75 Ohm Coaxial Cable
3	2	CA/3407-3	3' SCSI Data Cable

4.6.3 DMD20, DMD50 or DMD2050 with HSSI Interface

Figure 4-3 illustrates a 1:1 system using a RCS11 with the universal Interface connected to DMD20 or DMD50 Modems with 70/140 MHz option and G.703/HSSI Interfaces. Table 4-3 describes the connection hardware required.

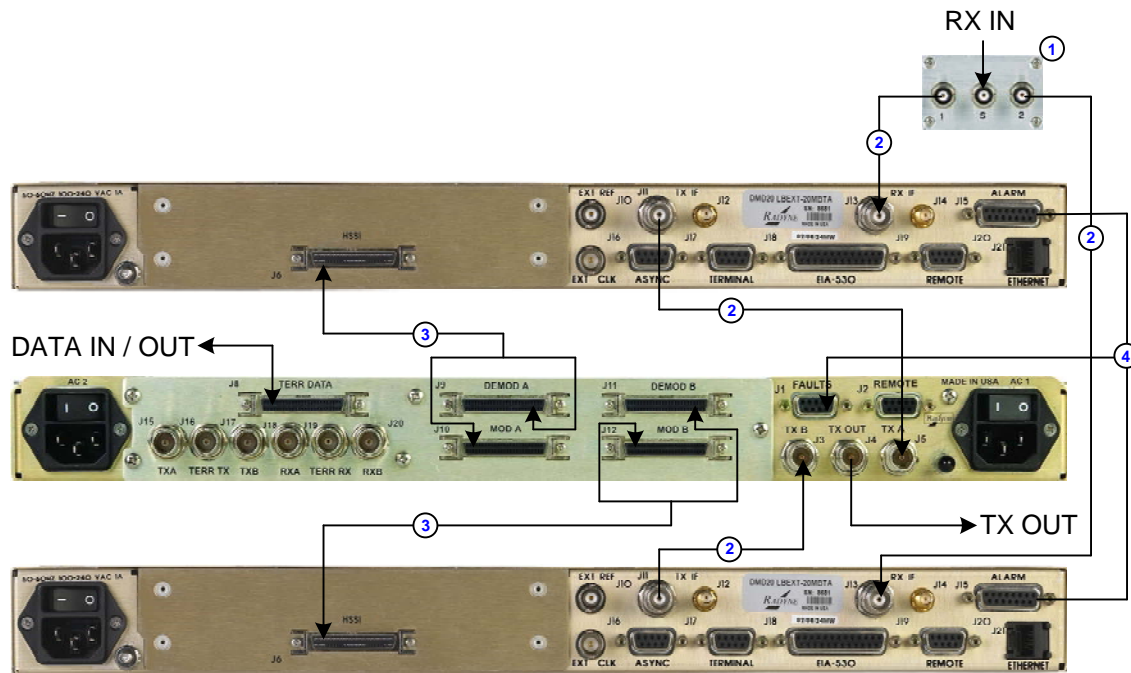

Figure 4-3. RCS11 with HSSI G.703 Interface Connected to DMD20, DMD50 or DMD2050 Modems with G.703 HSSI Interfaces

Table 4-3. Connection Hardware for 70/140 MHz Option			
Item No.	Quantity	Part Number	Discription
1	1	RF/ZSC-2-175	70/140 IF Splitter
2	4	CA/3598-36	3' BNC to BNC 75 Ohm Coaxial Cable
3	2	CA/4181	HSSI Data Cable
4	1	CA/3865	Alarm Fault Cable

4.6.4 DMD20, DMD50 or DMD2050 ASI / DVB with RCS11 ASI HSSI

Figure 4-4 illustrates a 1:1 system using a RCS11 with the HSSI / ASI Interface connected to DMD20 or DMD50 Modems with 70/140 MHz option utilizing the ASI DVB data Interfaces. Table 4-4 describes the connection hardware required.

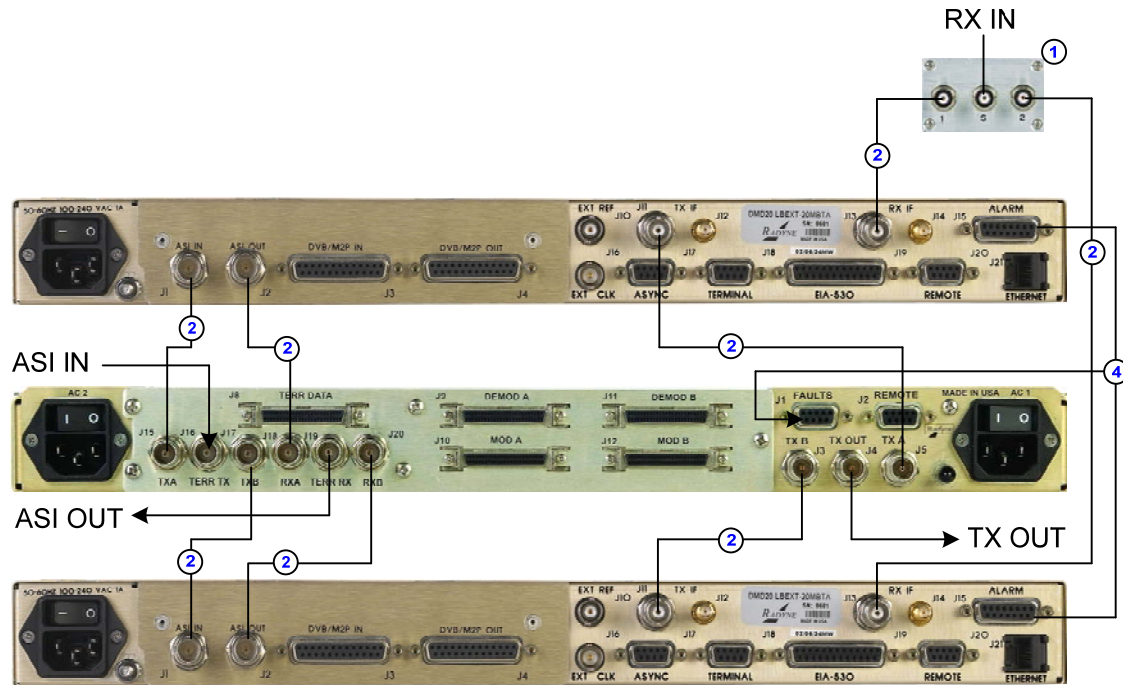

Figure 4-4. RCS11 with HSSI ASI Interface Connected to DMD20, DMD50 or DMD2050 Modems with ASI/DVB Interfaces

Table 4-4. Connection Hardware			
Item No.	Quantity	Part Number	Discription
1	1	RF/ZSC-2-175	70/140 IF Splitter
2	8	CA/3598-36	3' BNC to BNC 75 Ohm Coaxial Cable
3	1	CA/3865	Alarm Fault Cable

4.6.5 DMD20 HSSI

Figure 4-5 illustrates a 1:1 system using a RCS11 with the HSSI / ASI Interface connected to DMD20 Modems with HSSI Interfaces. Table 4-5 describes the connection hardware required.

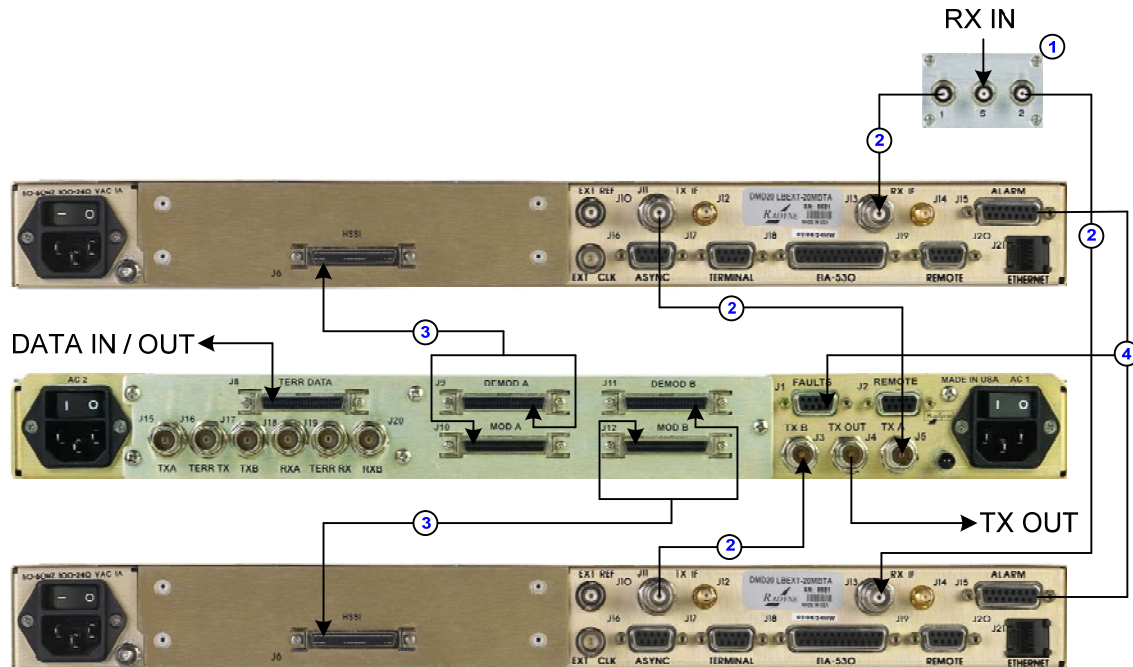

Figure 4-5. RCS11 with HSSI/ASI Interface Connected to DMD20 Modems with HSSI Interfaces

Table 4-5. Connection Hardware			
Item No.	Quantity	Part Number	Discription
1	1	RF/ZSC-2-175	70/140 IF Splitter
2	4	CA/3598-36	3' BNC to BNC 75 Ohm Coaxial Cable
3	2	CA/4181	HSSI Data Cable
4	1	CA/3865	Alarm Fault Cable

4.6.6 DMD20/DMD50/DMD2050 ETHERNET

Figure 4-6 illustrates a 1:1 system using a RCS11 with the Ethernet Interface connected to a DMD20, DMD50 or DMD2050 Modem with 70/140 MHz and Ethernet Data Interfaces. Table 4-6 describes the connection hardware required.

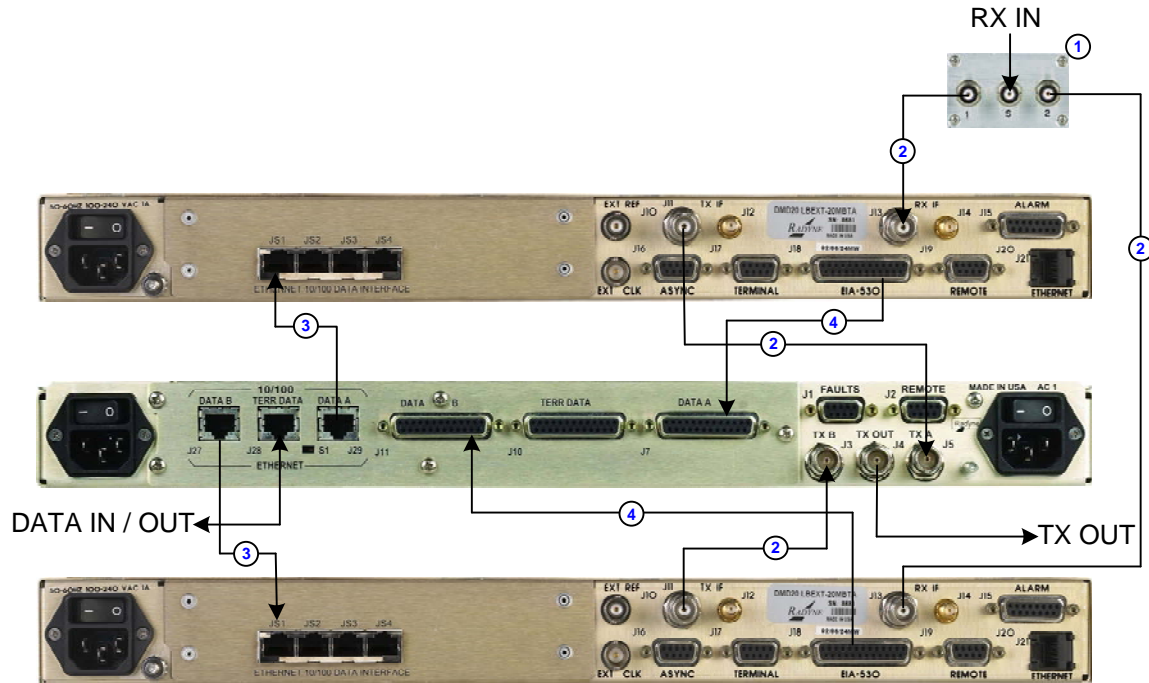

Figure 4-6. RCS11 with Ethernet Interface Connected to DMD20 Modems with Ethernet Interfaces

Table 4-6. Connection Hardware			
Item No.	Quantity	Part Number	Discription
1	1	RF/ZSC-2-175	70/140 IF Splitter
2	4	CA/3598-36	3' BNC to BNC 75 Ohm Coaxial Cable
3	2	CA/CAT5E-5FT	Cat 5
4	2	CA/5211-3	Data/Fault

4.6.7 DMD50 or DMD2050 T3 E3 STS1 With IDR/ESC

Figure 4-7 illustrates a 1:1 system using a RCS11 with the T3 E3 STS1 Interface connected to DMD50 or DMD2050 Modems with 70/140 MHz and T3/E3 Interface. Table 4-7 describes the connection hardware required.

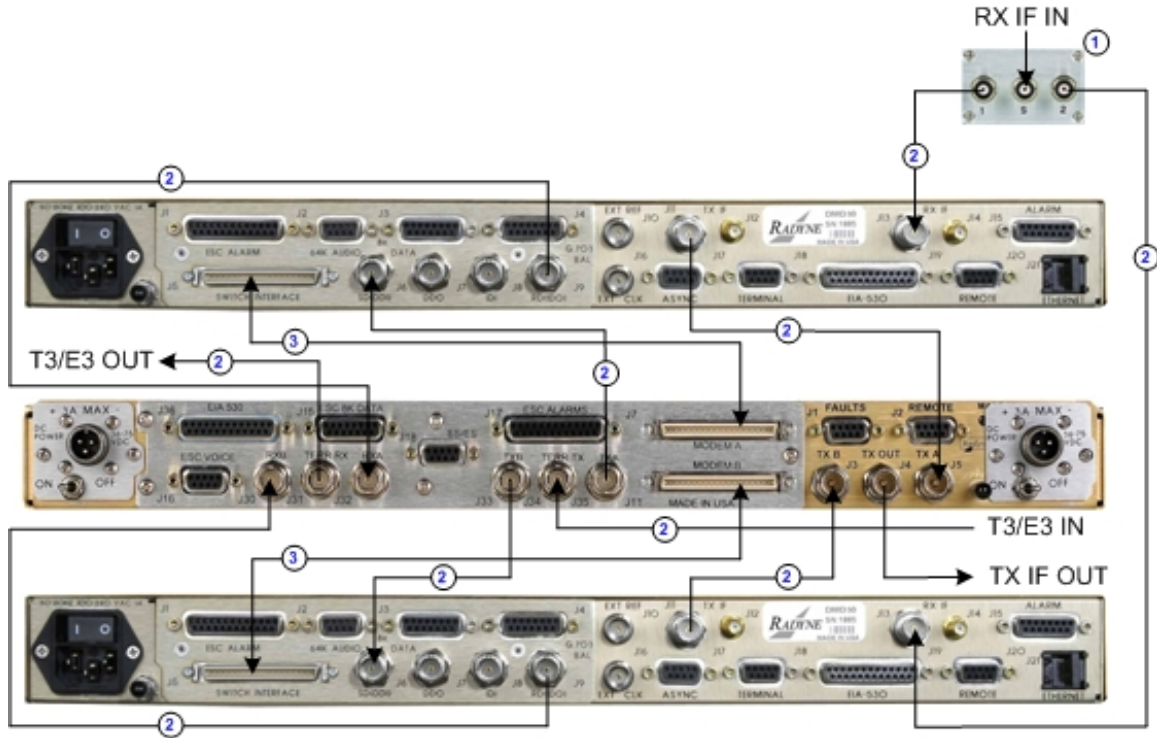

Figure 4-7. RCS11 with a E3/T3 STS1 Interface Connected to a DMD50 or DMD2050 Modems with a IDR/ESC Interface

Table 4-7. Connection Hardware			
Item No.	Quantity	Part Number	Discription
1	1	RF/ZSC-2-175	70/140 IF Splitter
2	8	CA/3598-36	3' BNC to BNC 75 Ohm Coaxial Cable
3	2	CA/3407-3	3' Data/Fault Cable

4.6.8 DM240 PIIC ASI Interface

Figure 4-8 illustrates a 1:1 system using a RCS11 with the ASI Interface connected to DM240 PIIC Modulators with 70/140 MHz and ASI PIIC Card. Table 4-8 describes the connection hardware required.

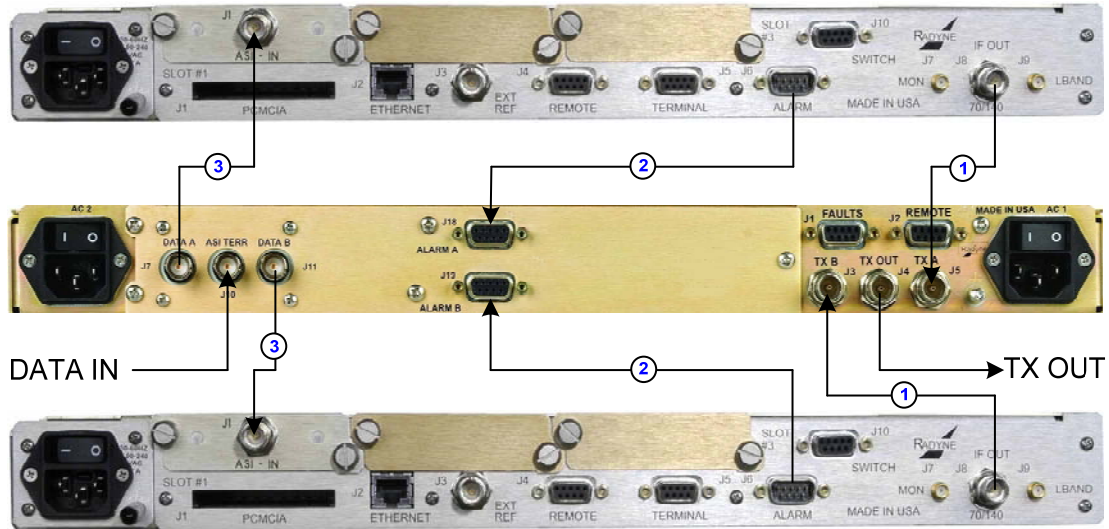

Figure 4-8. RCS11 with ASI Interface Connected to DM240 PIIC Modulators with an ASI PIIC Card

Table 4-8. Connection Hardware			
Item No.	Quantity	Part Number	Discription
1	2	CA/3598-36	3' BNC to BNC 75 Ohm Coaxial Cable
2	2	CA/3677-1	Alarm Fault Cable
3	2	CA/3598-36	3' BNC to BNC 75 Ohm ASI Cable

4.6.9 DM240XR ASI Data Interface

Figure 4-9 illustrates a 1:1 system using a RCS11 with 70/140 MHz, ASI Data Interface and optional Offline IF Monitor connected to DM240XR Modulators. Table 4-9 describes the connection hardware required.

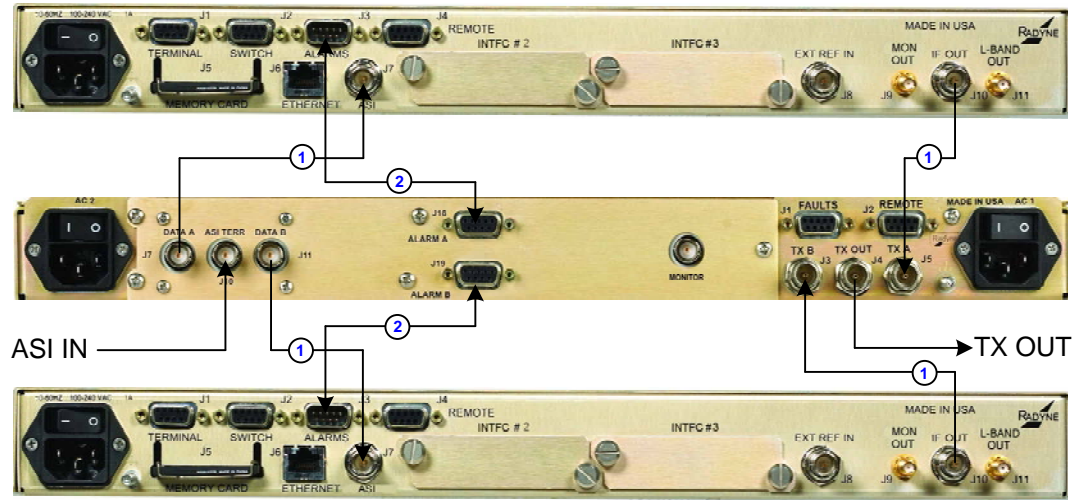

Figure 4-9. RCS11 with ASI Interface and optional Offline IF Monitor connected to DM240XR Modulators

Table 4-9. Connection Hardware			
Item No.	Quantity	Part Number	Discription
1	4	CA/3598-36	3' BNC to BNC 75 Ohm Coaxial Cable
2	2	CA/3677-1	Alarm Fault Cable

4.6.10 DD240XR Ethernet

Figure 4-10 illustrates a 1:1 system using a RCS11 with the Ethernet Interface connected to DD240XR Demodulators. Table 4-10 describes the connection hardware required.

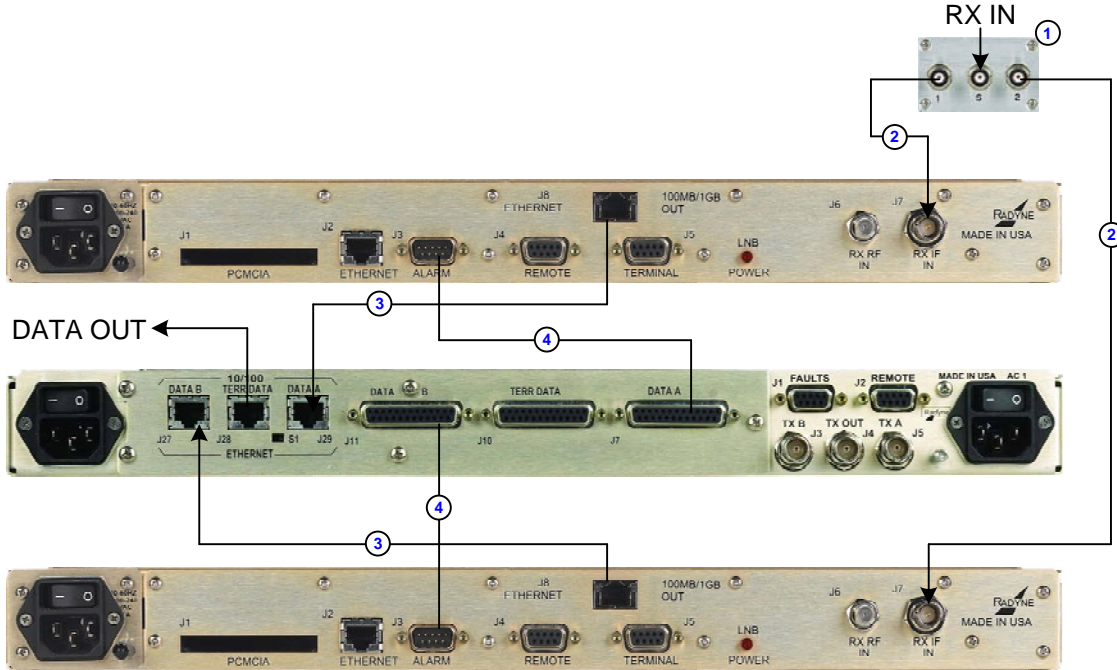

Figure 4-10. RCS11 with Ethernet Interface Connected to DD240XR Demodulators

Table 4-10. Connection Hardware			
Item No.	Quantity	Part Number	Discription
1	1	RF/ZSC-2-175	70/140 IF Splitter
2	2	CA/3598-36	3' BNC to BNC 75 Ohm Coaxial Cable
3	2	CA/CAT5E-5FT	Ethernet Cable
4	2	CA/5787	Alarm Fault Cable

4.6.11 DM240XR Ethernet

Figure 4-11 illustrates a 1:1 system using a RCS11 with the Ethernet Interface connected to DM240XR Demodulators. Table 4-11 describes the connection hardware required.

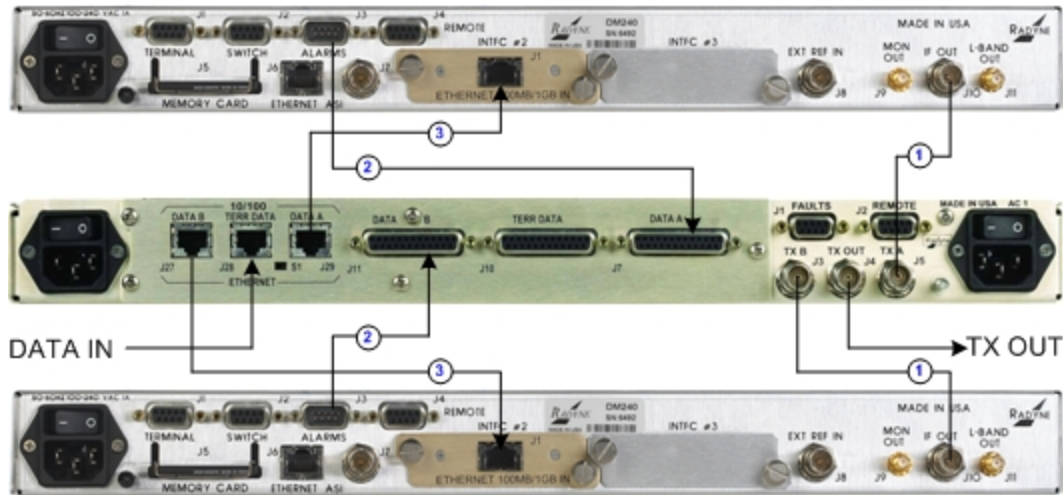

Figure 4-11. RCS11 with Ethernet Interface Connected to DM240XR Modulators

Table 4-11. Connection Hardware			
Item No.	Quantity	Part Number	Discription
1	2	CA/3598-36	3' BNC to BNC 75 Ohm Coaxial Cable
2	2	CA/5786	Alarm Fault Cable
3	2	CA/CAT5E-5FT	Ethernet Cable

4.6.12 DM240XR HSSI

Figure 4-12 illustrates a 1:1 system using a RCS11 with the HSSI / ASI Interface connected to DM240XR Demodulators with HSSI PIIC Cards. Table 4-12 describes the connection hardware required.

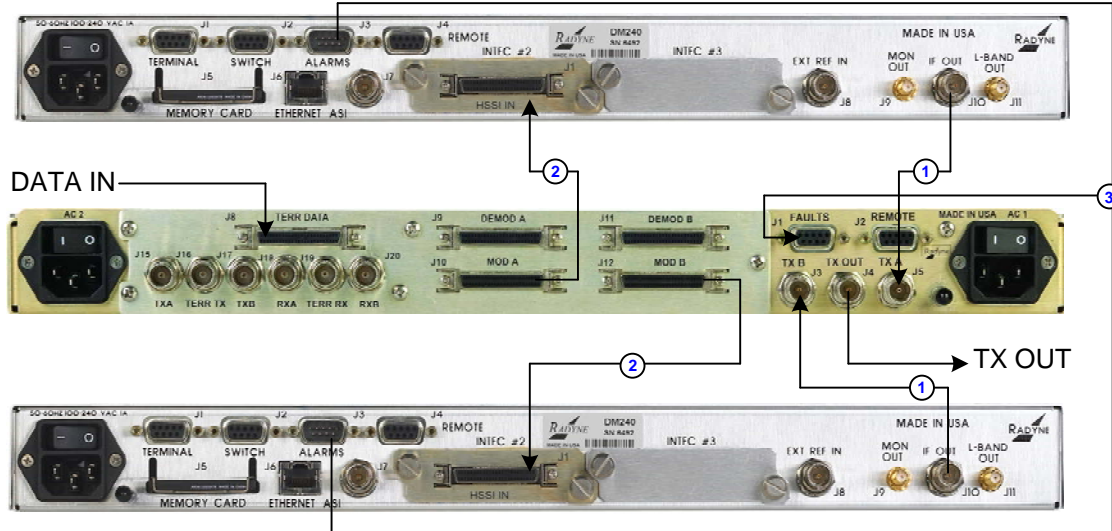

Figure 4-12. RCS11 with HSSI / ASI Interface Connected to DM240XR Modulators with HSSI PIIC Cards

Table 4-12. Connection Hardware			
Item No.	Quantity	Part Number	Discription
1	2	CA/3598-36	3' BNC to BNC 75 Ohm Coaxial Cable
2	2	CA/3841-2	2" HSSI Data Cable
3	1	CA/3865	Alarm Fault Cable

4.6.13 DM240XR DVB Parallel

Figure 4-13 illustrates a 1:1 system using a RCS11 with a DVB Parallel Interface connected to DM240XR Modulators with DVB / M2P Parallel PIIC Cards. Table 4-13 describes the connection hardware required.

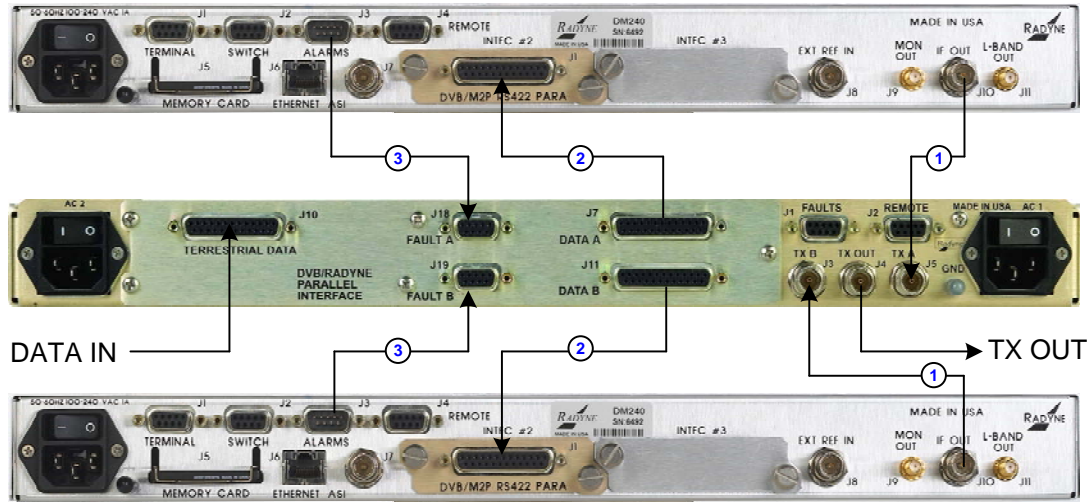

Figure 4-13. RCS11 with Parallel Interface Connected to DM240XR Modulators With DVB / Parallel PIIC Cards

Table 4-13. Connection Hardware			
Item No.	Quantity	Part Number	Discription
1	2	CA/3598-36	3' BNC to BNC 75 Ohm Coaxial Cable
2	2	CA/3473-4	4" Parallel Data Cable
3	2	CA/3677-1	Alarm Fault Cable

4.6.14 DD240XR HSSI

Figure 4-14 illustrates a 1:1 system using a RCS11 with the HSSI / ASI Interface connected to DD240XR Demodulators with 70/140 MHz IF and HSSI Data Interfaces. Table 4-14 describes the connection hardware required.

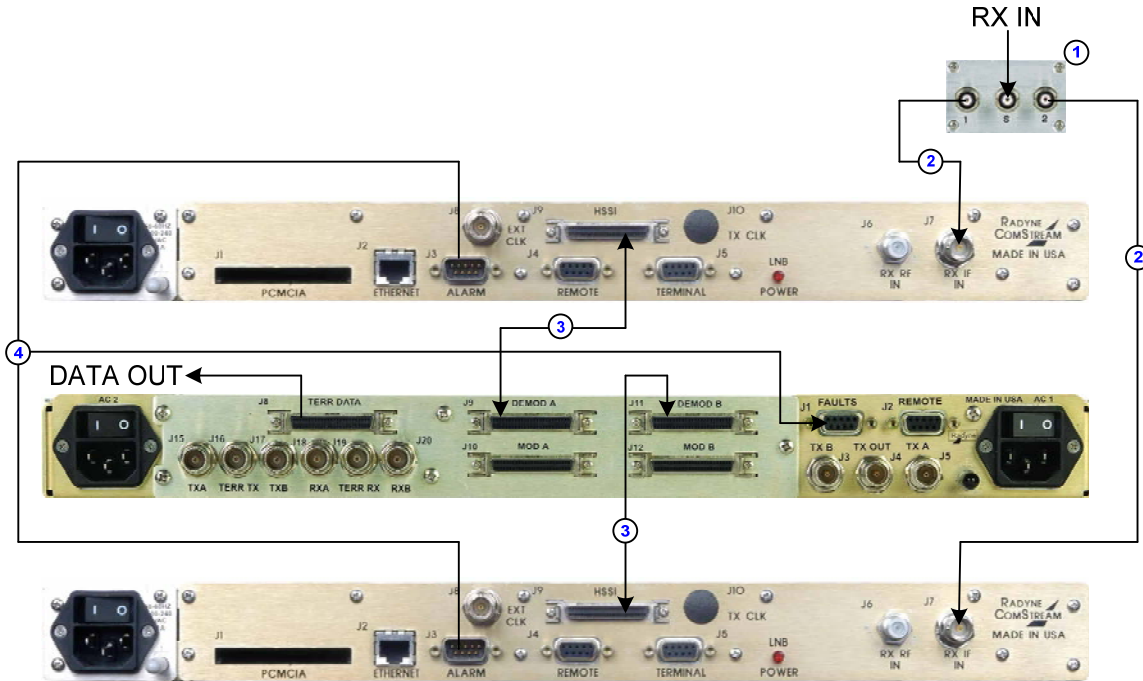

Figure 4-14. RCS11 with HSSI / ASI Interface connected to DD240XR Demodulators with HSSI Interface

Table 4-14. Connection Hardware			
Item No.	Quantity	Part Number	Discription
1	1	RF/ZSC-2-175	70/140 IF Splitter
2	2	CA/3598-36	3' BNC to BNC 75 Ohm Coaxial Cable
3	2	CA/3841-2	2" HSSI Data Cable
4	1	CA/3865	Alarm Fault Cable

4.6.15 DM240XR & DD240XR

Figure 4-15 illustrates an RCS11 1:1 system with the HSSI / ASI Interface connected to DM240XR Modulators and DD240XR Demodulators utilizing the HSSI Interfaces. Table 4-15 describes the connection hardware required.

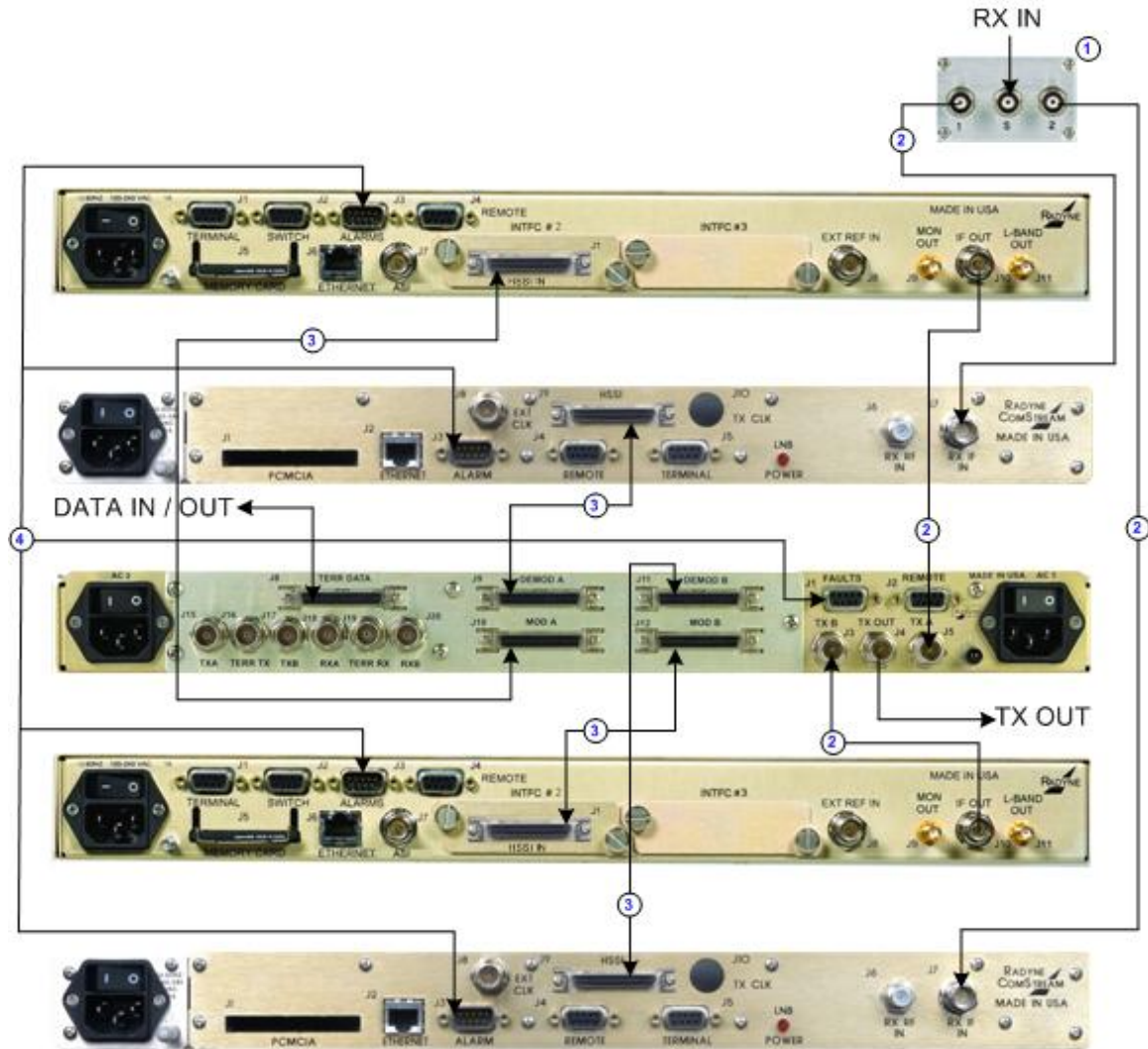

Figure 4-15. RCS11 with HSSI / ASI Interface Connected to DM240XR Modulators and DD240XR Demodulators with HSSI Interfaces

Table 4-15. Connection Hardware			
Item No.	Quantity	Part Number	Discription
1	1	RF/ZSC-2-175	70/140 IF Splitter
2	4	CA/3598-36	3' BNC to BNC 75 Ohm Coaxial Cable
3	4	CA/3841-2	2' HSSI Data Cable
4	1	CA/3865	Alarm Fault Cable

4.6.16 DMD20 (RS530) to RCS11 RS449/422 Serial Data Interface

Figure 4-16 illustrates an RCS11 1:1 system with the RS449 Serial Interface connected to DMD20's using the EIA-530 connection. Table 4-16 describes the connection hardware required.

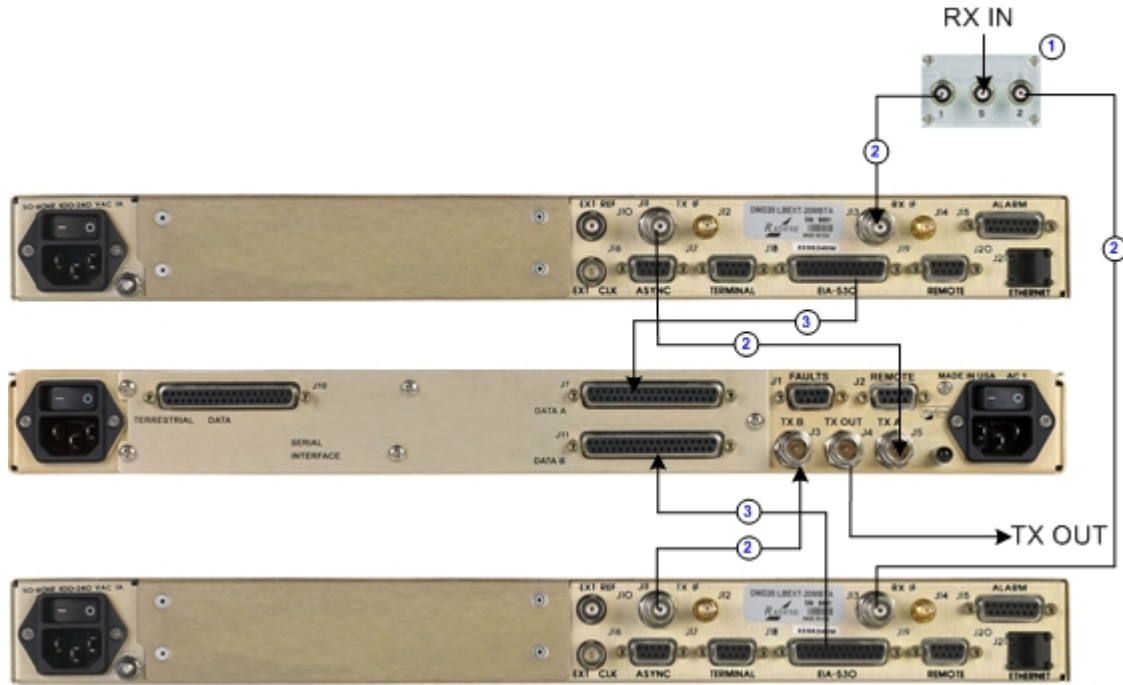

Figure 4-16. RCS11 with Serial Interface Connected to DMD20's

Table 4-16. Connection Hardware			
Item No.	Quantity	Part Number	Description
1	1	RF/ZSC-2-175	70/140 IF Splitter
2	4	CA/3598-36	3' BNC to BNC 75 Ohm Coaxial Cable
3	2	CA/5165-3	RS530 to RS449 Data Cable

4.6.17 DMD20LBST (RS530) to RCS11 RS449/422 Serial Data Interface

Figure 4-17 illustrates an RCS11 1:1 system with the RS449 Serial Data Interface connected to DMD20LBST's using the EIA-530 connection. RCS11 will not pass BUC Voltage. Table 4-17 describes the connection hardware required.

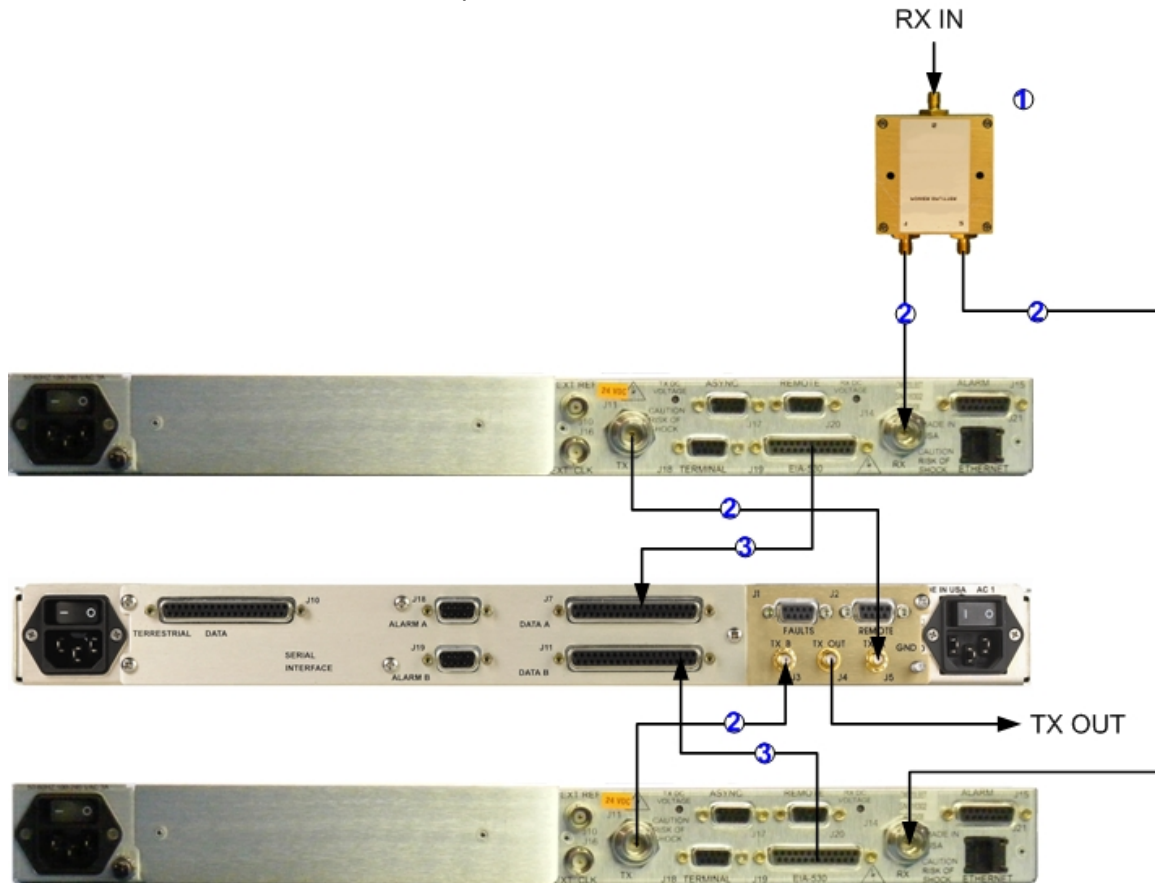



Figure 4-17. RCS11 with Serial Interface Connected to DMD20LBST's

Table 4-17. Connection Hardware			
Item No.	Quantity	Part Number	Description
1	1	RF/ZAPD-1750-5	SMA L-Band Splitter
2	4	CA/5127AMNM-28	28" SMA to N-Type 50 Ohm Cable
3	2	CA/5165-3	RS530 to RS449 Data Cable



WARNING

The RCS11 will not pass DC BUC Voltage from the DMD20LBST. Enabling DC BUC voltage will damage the RCS11 Switch.

Chapter 5. Connector Pinouts

5.1 RCS11 Connections

The RCS11 supports various rear panel hardware configurations. The following information describes the rear panel connections. Any connection interfacing to the RCS11 must be the appropriate mating connector.

5.2 AC Power Input/Switch

The AC Power Entry Modules (Figure 5-1) are located on the left and right sides of the unit. Primary power applied to the two ports with the supplied power cables is 10 – 240 VAC, 50 – 60 Hz. Integrated into each of the power entry module is the Power On/Off Rocker Switch. Power consumption for the unit is 1A. The Power Cord/Connector assembly is a supplied item. A chassis ground connection (size 10-32 thread) stud, is located to the lower left of the AC Power Cord.

5.3 DC Power Input/Switch

The Optional DC Power Input and Switch (Figure 5-1) is available for all RCS11 products. The unit may be powered from a 36 – 75 VDC source with a maximum unit power consumption of 3A. Figure 5-1 Illustrates the DC Power Input and Switch. Refer to Table 5-1 for pinouts.

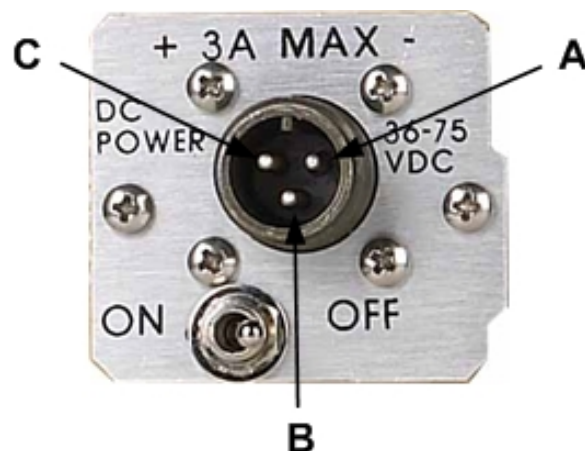

Figure 5-1. DC Power Input and Switch

Table 5-1 DC Power	
A	-
B	Ground
C	+

5.4 RCS11 COMMON CONNECTIONS

5.4.1 FAULTS (J1)

The Fault Port is a 9-Pin Female 'D' Connector. This does not include the HSSI interface. Refer to Table 5-2 for pinouts.

Table 5-2 Fault Port – 9-Pin Female 'D' Connector		
Pin No.	Description	Status
1	Switch Fault Relay	Common
2	Switch Fault Relay	Normally Open
3	Mod B Selected Relay	Normally Closed
4	Demod B Selected Relay	Common
5	Demod B Selected Relay	Normally Open
6	Switch Fault Relay	Normally Closed
7	Mod B Selected Relay	Common
8	Mod B Selected Relay	Normally Open
9	Demod B Selected Relay	Normally Closed

5.4.2 REMOTE (J2)

The Remote Control Port is a 9-Pin Female 'D' Connector. Refer to Table 5-3 for pinouts.

Table 5-3. Remote Port – 9-Pin Female 'D' Connector (J2)		
Pin Number	Description	Signal
1	*RS-485 Remote RLLP Select	
2	RX RS232	Input
3	TX RS232	Output
4	NC	NA
5	Ground	GND
6	RX (A) – RS485	Input

7	RX (B) + RS485	Input
8	TX (A) – RS485	Output
9	TX (B) + RS485	Output

* **Note:** Connect to Ground on power up to enable RS485 Mode

5.4.3 TX B (J3)

The TX B is the TX IF input from the modulator. If the RCS11 is configured for a 70 or 140 MHz application, then this connector is either a 75 Ohm or 50 Ohm BNC connector. If the switch is configured for L-Band, then this connector is a 50 Ohm SMA female connector.

5.4.4 TX OUT (J4)

The TX OUT is the TX IF Output from the switch. If the RCS11 is configured for a 70 or 140 MHz application, then this connector is either a 75 Ohm or 50 Ohm BNC connector. If the switch is configured for L-Band, then this connector is a 50 Ohm SMA female connector.

5.4.5 TX A (J5)

The TX A is the TX IF input from the modulator. If the RCS11 is configured for a 70 or 140 MHz application, then this connector is either a 75 Ohm or 50 Ohm BNC connector. If the switch is configured for L-Band, then this connector is a 50 Ohm SMA female connector.

5.4.6 GND

The Chassis Ground connection is located on the rear panel next to the AC input power entry module. The Chassis ground connection is a #10-32 threaded stud.

5.5 UNIVERSAL G.703/SYNCHRONOUS INTERFACE

The RCS11 Universal G703/Synchronous Interface supports G703 (Balanced & Unbalanced) and synchronous data for the DMD15, DMD20 and the DMD50 products.

5.5.1 SYNC DATA (J7)

The Sync Data Port is a 37-Pin RS449 Female 'D' Connector. This port is the user interface for Synchronous RS-422 / RS-485 / RS-232 / V.35 Data. Refer to Table 5-4 for pinouts.

Table 5-4. J8 SYNC DATA		
Pin Number	Description	Signal
1,19,20,37	Ground	GND
2,10,12,14,18,28,30,32,34,36	Not Used	NA
3	Transmit Octet (A) -	Input
4	Send Data (A) -	Input
5	Send Timing (A) -	Output

6	Receive Data (A) -	Output
7	Request To Send (A) -	Input
8	Receive Timing (A) -	Output
9	Clear To Send (A) -	Output
11	Data Mode (A) -	Output
13	Receive Ready (A) -	Output
15	External Clock (A) -	Input
16	Receive Octet (A) -	Output
17	Terminal Timing (A) -	Input
21	Transmit Octet (B) +	Input
22	Send Data (B) +	Input
23	Send Timing (B) +	Output
24	Receive Data (B) +	Output
25	Request To Send (B) +	Input
26	Receive Timing (B) +	Output
27	Clear To Send (B) +	Output
29	Data Mode (B) +	Output
31	Receive Ready (B) +	Output
33	External Clock (B) +	Input
34	Receive Octet (B) +	Output
35	Terminal Timing (B) +	Input

5.5.2 MODEM A & B (J7 & J11) G703/RS422 Serial Universal Interface w/SCSI connectors

The Modem Channel a Port is a 68-Pin High-Density Female SCSI Connector. This port is the data interface used to connect to the primary and backup modems. This interface supplies the RS422 Synchronous, G703, IDR and IBS data information from the modems. Refer to Table 5-5 for pinouts.

Pin No.	Description	Signal
1	G.703 Send Data (A) -	Output
2	Synch Data Send Data (A) -	Output
3	IDR ESC Backward Alarm 1	Common
4	G.703 Insert Data Input (A) -	Output
5	Synch Data Send Timing (A) -	Input
6	IDR ESC Backward Alarm 1	Normally Open
7	Synch Data Terminal Timing (A) -	Output
8	IDR ESC Backward Alarm 2	Normally Closed
9	G.703 Drop Data Out (A) - / Synch Data Receive Timing (A)-	Input

10	IDR ESC Backward Alarm 3	Common
11	G.703 Insert Data Out (A) - Synch Data Receive Data (A)	Input
12	IDR ESC Backward Alarm 3	Normally Open
13	External Clock (A) -	Output
14, 48, 57	Ground	GND
15	IDR ESC Audio Input Channel 1 (A) -	Output
16	IDR ESC Audio Input Channel 2 (A) -	Output
17	IDR ESC Audio Output Channel 1 (A) -	Input
18	IDR ESC Audio Output Channel 2 (A) -	Input
19	IDR ESC Backward Alarm Input 3	Output
20	IBS ES Transmit Data (A) - / IDR ESC Backward Alarm 1	Output
21	Mod Fault Open Collector	Input
22	IBS ES Receive Data (A) -	Input
23	IBS ES Data Set Ready (RS-232 Only)	Input
24	IDR ESC Transmit 8 Kbps Clock (A) -	Input
25	IDR ESC Transmit 8 Kbps Data (A) -	Output
26	IDR ESC Receive 8 Kbps Clock	Input
27	IDR ESC Receive 8 Kbps Data	Input
28	IDR ESC Backward Alarm Output 4	Normally Closed
29	IBS Transmit Octet (A) -	Output
30	Synch Data Data Mode (A) -	Input
31	Synch Data Clear to Send (A) -	Input
32	IBS Receive Octet (A) -	Input
33	Synch Data Request to Send (A) -	Output
34	Synch Data Receiver Ready (A) -	Input
35	G.703 Send Data (B) +	Output
36	Synch Data Send Data Input (B) +	Output
37	IDR ESC Backward Alarm 1	Normally Closed
38	G.703 Insert Data Input (B) +	Output
39	Synch Data Send Timing (B) +	Input
40	IDR ESC Backward Alarm Out 2	Common
41	Synch Data Terminal Timing (B) +	Output
42	IDR ESC Backward Alarm 2	Normally Open
43	G.703 Drop Data Out (B) + / Synch Data Receive Timing (B) +	Input
44	IDR ESC Backward Alarm 3	Normally Closed
45	G.703 Receive Data (B) + / Synch Data Receive Data (B) +	Input
46	IDR ESC Backward Alarm 4	Common
47	External Clock (B) +	Output
49	IDR ESC Audio Input Channel 1 (B) +	Output

50	IDR ESC Audio Input Channel 2 (B) +	Output
51	IDR ESC Audio Output Channel 1 (B) +	Input
52	IDR ESC Audio Output Channel 2 (B) +	Input
53	IDR ESC Backward Alarm 4	Output
54	IBS ES Transmit Data (B) + / Synch Data Receive Data (B) +	Output
55	Demod Fault Open Collector	Input
56	IBS ES Receive Data (B) +	Input
58	IDR ESC Transmit 8 Kbps Clock (B) +	Input
59	IDR ESC Transmit 8 Kbps Data (B) +	Output
60	IDR ESC Receive 8 Kbps Clock (B) +	Input
61	IDR ESC Receive 8 Kbps Data (B) +	Input
62	IDR ESC Backward Alarm 4	Normally Open
63	IBS Transmit Octet (B) +	Output
64	Synch Data - Data Mode (B) +	Input
65	Synch Data - Clear to Send (B) +	Output
66	IBS Receive Octet (B) +	Input
67	Synchronous Data Request to Send (B) +	Output
68	Synchronous Data Receiver Ready (B) +	Input

5.5.3 ESC 8K DATA (J15)

The ESC 8K Data Port is a 15-Pin Female 'D' Connector. Refer to Table 5-6 for pinouts.

Pin No.	Description	Signal
1	Rx Octet-B	Output
2	Rx Clock-B	Output
3	Rx Data-B	Output
4,5	Not Used	N/A
6	Tx Data-A	Input
7	Tx Clock-A	Output
8	Tx Octet-A	Output
9	Rx Octet-A	Output
10	Rx Clock-A	Output
11	Rx Data-A	Output
12	Ground	GND
13	Tx Data-B	Input
14	Tx Clock-B	Output
15	Tx Octet-B	Output

5.5.4 ESC VOICE (J16)

The ESC Voice Port is a 9-Pin Female 'D' Connector. Refer to Table 5-6 for pinouts.

Table 5-6. ESC Voice - 9-Pin Female 'D' Connector (J16)		
Pin No.	Description	Signal
1	Tx Audio 1A	Input
2	Rx Audio 1A	Output
3	Ground	GND
4	Tx Audio 2B	Input
5	Rx Audio 2A	Output
6	Tx Audio 1B	Input
7	Rx Audio 1B	Output
8	Tx Audio 2A	Input
9	Rx Audio 2A	Output

5.5.5 ESC Alarms (J17)

The ESC Alarm Port is a 25-Pin Female 'D' Connector. Refer to Table 5-7 for pinouts.

Table 5-7. J17 ESC ALARMS (25-Pin Female 'D')		
Pin #	Description	Signal
1, 7	Ground	GND
2	Backward Alarm Out 1	Normally Open
3, 5, 9, 12, 13, 24, 25	Not Used	NA
4	Backward Alarm Out 2	Normally Open
6	Backward Alarm Out 3	Normally Open
8	Backward Alarm Out 4	Normally Open
10	Backward Alarm In 2	Input
11	Backward Alarm In 4	Input
14	Backward Alarm Out 1	Common
15	Backward Alarm Out 1	Normally Closed
16	Backward Alarm Out 2	Common
17	Backward Alarm Out 2	Normally Closed
18	Backward Alarm Out 3	Common
19	Backward Alarm Out 3	Normally Closed
20	Backward Alarm Out 4	Common
21	Backward Alarm Out 4	Normally Closed
22	Backward Alarm In 1	Input
23	Backward Alarm In 3	Input

5.5.6 ES/ES (J18) Universal Interface

The Earth Station to Earth Station (ES/ES) is a 9 Pin Female 'D' port. Refer to Table 5-8 for pinouts.

Table 5-8. ES/ES Port - 9-Pin Female 'D' Connector (J18)		
Pin No.	Signal Name	Description
1	RXD-B	Receive Data B
6	DSR	Date Set Ready
2	RXD-A	Receive Data A
7	RTS	Request to Send (Pin 7 & 8 Tied Together)
3	TXD-A	Transmit Data A
8	CTS	Clear to Send
4	TXD-B	Transmit Data B
9	NC	No Connection
5	GROUND	Signal Ground

5.5.7 G.703 Balanced (J20)

The G.703 Port is a Balanced 15-Pin Female 'D' Connector. Refer to Table 5-9 for pinouts.

Table 5-9. J20 - G.703 (Balanced)(15-Pin Female 'D')		
Pin #	Description	Signal
1	Send Data (A) -	Input
2, 4	Ground	GND
3	Receive Data (A) -	Output
5	Drop Data Out (B) +	Output
6	Insert Data In (B) +/EXC (B) +	Input
7	External Clock (A) -	Input
8	External Clock (B) +	Input
9	Send Data (B) +	Input
10, 14, 15	NC	NA
11	Receive Data (B) +	Output
12	Drop Data Out (A) -	Output
13	Insert Data In (A) -/EXC (A) -	Input

5.5.8 SD (DDI) (J23)

The Send Data (Drop Data In) Port (Unbalanced) is a 75-Ohm Female BNC Connector.

5.5.9 DDO (J24)

The Drop Data Out Port (Unbalanced) is a 75-Ohm Female BNC Connector.

5.5.10 IDI (J25)

The Insert Data In Port (Unbalanced) is a 75-Ohm Female BNC Connector.

5.5.11 RD (IDO) (J26)

The Receive Data (Insert Data Out) Port (Unbalanced) is a 75-Ohm Female BNC Connector.

5.6 ASI Data Interface

The RCS11 ASI Data Interface supports ASI serial data for the DM240XR Modulator or DD240XR Demodulator only application.

5.6.1 DATA A (J7)

The Data (A) is the serial ASI data interface from the modulator or demodulator (A). This interface is a 75 Ohm BNC connector.

5.6.2 ASI TERR (J10)

The ASI Terrestrial is the user interface. This interface is a 75 ohm BNC connector.

5.6.3 DATA B (J11)

The Data (B) is the serial ASI data interface from the modulator or demodulator (B). This interface is a 75 Ohm BNC connector.

5.6.4 Alarm A (J18)

The Alarm A Interface is a 9 Pin Female 'D' port. Refer to Table 5-10 for pinouts.

Table 5-10. J18 Alarm A (9-Pin Female 'D')		
Pin #	Signal Name	Direction
1, 2, 3, 5, 7, 8, 9	NC	NA
4	Ground	GND
6	Mod Fault Open Collector	Input

5.6.5 Alarm B (J19)

The Alarm B interface is a 9 Pin Female 'D' port. Refer to Table 5-11 for pinouts.

Table 5-11. J18 Alarm A (9-Pin Female 'D')		
Pin #	Signal Name	Direction
1, 2, 3, 5, 7, 8, 9	NC	NA
4	Ground	GND
6	Mod Fault Open Collector	Input

5.7 DVB Parallel Interfaces

The DVB Parallel Interface is a 25-Pin Female connector supporting DM240XR Modulator and DD240XR Demodulator products. This port supports DVB/M2P Parallel RS422 or LVDS protocols. The modulators or Demodulators must be configured to support RS422 or LVDS protocol.

5.7.1 Data A & Data B DVB Parallel Interface (J7)

The Data A and Data B DVB Parallel Interface (J7 & J11) is a 25-Pin Female 'D' port. This interface connects to (A) or (B) Modulator or Demodulator. Refer to Table 5-12 for pinouts.

Table 5-12. J7 Data A (DVB Parallel) (25-Pin Female 'D')		
Pin No.	Description	Signal
1	Clock +	Output
2, 15	System Ground	GND
3	D7 +	Output
4	D6 +	Output
5	D5 +	Output
6	D4 +	Output
7	D3 +	Output
8	D2 +	Output
9	D1 +	Output
10	D0 +	Output
11	DVALID +	Output
12	PSYNC +	Output
13	Cable Shield	Output
14	Clock -	Output
16	D7 -	Output
17	D6 -	Output
18	D5 -	Output
19	D4 -	Output

20	D3 -	Output
21	D2 -	Output
22	D1 -	Output
23	D0 -	Output
24	DVALID -	Output
25	PSYNC -	Output

5.7.1.1 Data A & Data B M2P Parallel Interface (J7 & J11)

The Data A and Data B M2P Parallel Interface (J7 & J11) is a 25-Pin Female 'D' port. This interface connects to (A) or (B) Modulator or Demodulator. Refer to Table 5-13 for pinouts.

Table 5-13. J7 Data A (M2P Parallel) (25-Pin Female 'D')		
Pin No.	Description	Signal
1	OUTCLK +	Input
14	OUTCLK -	Input
2	CLK +	Output
15	CLK -	Output
3	SYNC +	Output
16	SYNC -	Output
4	VALID +	Output
17	VALID -	Output
5	D0 +	Output
18	D0 -	Output
6	D1 +	Output
19	D1 -	Output
7	D2 +	Output
20	D2 -	Output
8	D3 +	Output
21	D3 -	Output
9	D4 +	Output
22	D4 -	Output
10	D5 +	Output
23	D5 -	Output
11	D6 +	Output
24	D6 -	Output
12	D7 +	Output
25	D7 -	Output
13	NC	NA

5.7.2 Terrestrial Data (J10) DVB Parallel Interface

The Terrestrial Data (J10) DVB Parallel Interface is a 25-Pin Female 'D' port. Refer to Table 5-14 for pinouts.

Table 5-14. J10 Terrestrial Data (DVB Parallel) (25-Pin Female 'D')		
Pin #	Description	Signal
1	Clock +	Input
2, 15	System Ground	GND
3	D7 +	Input
4	D6 +	Input
5	D5 +	Input
6	D4 +	Input
7	D3 +	Input
8	D2 +	Input
9	D1 +	Input
10	D0 +	Input
11	DVALID +	Input
12	PSYNC +	Input
13	Cable Shield	Input
14	Clock -	Input
16	D7 -	Input
17	D6 -	Input
18	D5 -	Input
19	D4 -	Input
20	D3 -	Input
21	D2 -	Input
22	D1 -	Input
23	D0 -	Input
24	DVALID -	Input
25	PSYNC -	NA

5.7.2.1 Terrestrial Data (J10) M2P Data Interface

The Terrestrial Data (J10) M2P Interface is a 25-Pin Female 'D' port. Refer to Table 5-15 for pinouts.

Table 5-15. J10 Terrestrial Data (M2P Parallel) (25-Pin Female 'D')		
Pin No.	Description	Signal
1	OUTCLK +	Output
14	OUTCLK -	Output
2	CLK +	Input
15	CLK -	Input
3	SYNC +	Input
16	SYNC -	Input
4	VALID +	Input
17	VALID -	Input
5	D0 +	Input
18	D0 -	Input
6	D1 +	Input
19	D1 -	Input
7	D2 +	Input
20	D2 -	Input
8	D3 +	Input
21	D3 -	Input
9	D4 +	Input
22	D4 -	Input
10	D5 +	Input
23	D5 -	Input
11	D6 +	Input
24	D6 -	Input
12	D7 +	Input
25	D7 -	Input
13	NC	NA

5.7.3 Alarm A (J18)

The Alarm A Interface is a 9 Pin Female 'D' port. Refer to Table 5-16 for pinouts.

Table 5-16. J18 Alarm A (9-Pin Female 'D')		
Pin #	Signal Name	Direction
1, 2, 3, 5, 7, 8, 9	NC	NA
4	Ground	GND
6	Mod Fault Open Collector	Input

5.7.4 Alarm B (J19)

The Alarm B interface is a 9 Pin Female 'D' port. Refer to Table 5-17 for pinouts.

Table 5-17. J18 Alarm A (9-Pin Female 'D')		
Pin #	Signal Name	Direction
1, 2, 3, 5, 7, 8, 9	NC	NA
4	Ground	GND
6	Mod Fault Open Collector	Input

5.8 DMD50 UNIVERSAL G703 T3/E3 & RS422 SERIAL INTERFACE w/SCSI

The RCS11 Universal G703 Unbalanced/Synchronous Interface supports RS422 Serial data and G703 T3/E3 & STS1 data rates for the DMD50.

5.8.1 EIA 530 (J36)

The EIA-530 is a 25 Pin Female 'D' port. This port is the user interface for Synchronous RS-422/ V.35 Data Refer to Table 5-18 for pinouts.

Table 5-18. J36 EIA-530 (25-Pin Female 'D')		
Pin No.	Signal Name	Direction
1	Shield	GND
2	Send Data A (-)	Input
3	Receive Data A (-)	Output
4	Request To Send A (-)	Input
5	Clear To Send A (-)	Output
6	Data Mode A (-)	Output
7	Signal Ground	GND
8	Receiver Ready A (-)	Output
9	Receive Timing B (+)	Output
10	Receiver Ready B (+)	Output

11	Terminal Timing B (+)	Input
12	Send Timing B (+)	Output
13	Clear T Send B (+)	Output
14	Send Data B (+)	Input
15	Send Timing A (-)	Output
16	Receive Data B (+)	Output
17	Receive Timing A (-)	Output
18, 21, 25	NC	NA
19	Request To Send B (+)	Input
20	Data Terminal Ready A (-)	Input
22	Data Mode B (+)	Output
23	Data Terminal Ready B (+)	Input
24	Terminal Timing A (-)	Input

5.8.2 MODEM A & B (J7 & J11) Universal Interface, G703/Synchronous Data w/SCSI connectors

The Modem Channel a Port is a 68-Pin High-Density Female SCSI Connector. This port is the data interface used to connect to the primary and backup modems. This interface supplies the Synchronous, G703, IDR and IBS data information from the modems. Refer to Table 5-19 for pinouts.

Table 5-19 J7 & J11 MODEM A (68-Pin Female High Density Connector)

Pin No.	Description	Signal
1	G.703 Send Data (A) -	Output
2	Synch Data Send Data (A) -	Output
3	IDR ESC Backward Alarm 1	Common
4	G.703 Insert Data Input (A) -	Output
5	Synch Data Send Timing (A) -	Input
6	IDR ESC Backward Alarm 1	Normally Open
7	Synch Data Terminal Timing (A) -	Output
8	IDR ESC Backward Alarm 2	Normally Closed
9	G.703 Drop Data Out (A) - / Synch Data Receive Timing (A)-	Input
10	IDR ESC Backward Alarm 3	Common
11	G.703 Insert Data Out (A) - Synch Data Receive Data (A)	Input
12	IDR ESC Backward Alarm 3	Normally Open
13	External Clock (A) -	Output
14, 48, 57	Ground	GND
15	IDR ESC Audio Input Channel 1 (A) -	Output
16	IDR ESC Audio Input Channel 2 (A) -	Output
17	IDR ESC Audio Output Channel 1 (A) -	Input

18	IDR ESC Audio Output Channel 2 (A) -	Input
19	IDR ESC Backward Alarm Input 3	Output
20	IBS ES Transmit Data (A) - / IDR ESC Backward Alarm 1	Output
21	Mod Fault Open Collector	Input
22	IBS ES Receive Data (A) -	Input
23	IBS ES Data Set Ready (RS-232 Only)	Input
24	IDR ESC Transmit 8 Kbps Clock (A) -	Input
25	IDR ESC Transmit 8 Kbps Data (A) -	Output
26	IDR ESC Receive 8 Kbps Clock	Input
27	IDR ESC Receive 8 Kbps Data	Input
28	IDR ESC Backward Alarm Output 4	Normally Closed
29	IBS Transmit Octet (A) -	Output
30	Synch Data Data Mode (A) -	Input
31	Synch Data Clear to Send (A) -	Input
32	IBS Receive Octet (A) -	Input
33	Synch Data Request to Send (A) -	Output
34	Synch Data Receiver Ready (A) -	Input
35	G.703 Send Data (B) +	Output
36	Synch Data Send Data Input (B) +	Output
37	IDR ESC Backward Alarm 1	Normally Closed
38	G.703 Insert Data Input (B) +	Output
39	Synch Data Send Timing (B) +	Input
40	IDR ESC Backward Alarm Out 2	Common
41	Synch Data Terminal Timing (B) +	Output
42	IDR ESC Backward Alarm 2	Normally Open
43	G.703 Drop Data Out (B) + / Synch Data Receive Timing (B) +	Input
44	IDR ESC Backward Alarm 3	Normally Closed
45	G.703 Receive Data (B) + / Synch Data Receive Data (B) +	Input
46	IDR ESC Backward Alarm 4	Common
47	External Clock (B) +	Output
49	IDR ESC Audio Input Channel 1 (B) +	Output
50	IDR ESC Audio Input Channel 2 (B) +	Output
51	IDR ESC Audio Output Channel 1 (B) +	Input
52	IDR ESC Audio Output Channel 2 (B) +	Input
53	IDR ESC Backward Alarm 4	Output
54	IBS ES Transmit Data (B) + / Synch Data Receive Data (B) +	Output
55	Demod Fault Open Collector	Input
56	IBS ES Receive Data (B) +	Input
58	IDR ESC Transmit 8 Kbps Clock (B) +	Input

59	IDR ESC Transmit 8 Kbps Data (B) +	Output
60	IDR ESC Receive 8 Kbps Clock (B) +	Input
61	IDR ESC Receive 8 Kbps Data (B) +	Input
62	IDR ESC Backward Alarm 4	Normally Open
63	IBS Transmit Octet (B) +	Output
64	Synch Data - Data Mode (B) +	Input
65	Synch Data - Clear to Send (B) +	Output
66	IBS Receive Octet (B) +	Input
67	Synchronous Data Request to Send (B) +	Output
68	Synchronous Data Receiver Ready (B) +	Input

5.8.3 ESC 8K DATA (J15)

The ESC 8K Data Port is a 15-Pin Female 'D' Connector. Refer to Table 5-20 for pinouts.

Table 5-20. ESC 8K Data Interface - 15-Pin Female 'D' Connector (J15)		
Pin No.	Description	Signal
1	Rx Octet-B	Output
2	Rx Clock-B	Output
3	Rx Data-B	Output
4,5	Not Used	N/A
6	Tx Data-A	Input
7	Tx Clock-A	Output
8	Tx Octet-A	Output
9	Rx Octet-A	Output
10	Rx Clock-A	Output
11	Rx Data-A	Output
12	Ground	GND
13	Tx Data-B	Input
14	Tx Clock-B	Output
15	Tx Octet-B	Output

5.8.4 ESC VOICE (J16)

The ESC Voice Port is a 9-Pin Female 'D' Connector. Refer to Table 5-21 for pinouts.

Table 5-21. ESC Voice - 9-Pin Female 'D' Connector (J16)		
Pin No.	Description	Signal
1	Tx Audio 1A	Input
2	Rx Audio 1A	Output

3	Ground	GND
4	Tx Audio 2B	Input
5	Rx Audio 2A	Output
6	Tx Audio 1B	Input
7	Rx Audio 1B	Output
8	Tx Audio 2A	Input
9	Rx Audio 2A	Output

5.8.5 ESC Alarms (J17)

The ESC Alarm Port is a 25-Pin Female 'D' Connector. Refer to Table 5-22 for pinouts.

Table 5-22. J17 ESC ALARMS (25-Pin Female 'D')		
Pin #	Description	Signal
1, 7	Ground	GND
2	Backward Alarm Out 1	Normally Open
3, 5, 9, 12, 13, 24, 25	Not Used	NA
4	Backward Alarm Out 2	Normally Open
6	Backward Alarm Out 3	Normally Open
8	Backward Alarm Out 4	Normally Open
10	Backward Alarm In 2	Input
11	Backward Alarm In 4	Input
14	Backward Alarm Out 1	Common
15	Backward Alarm Out 1	Normally Closed
16	Backward Alarm Out 2	Common
17	Backward Alarm Out 2	Normally Closed
18	Backward Alarm Out 3	Common
19	Backward Alarm Out 3	Normally Closed
20	Backward Alarm Out 4	Common
21	Backward Alarm Out 4	Normally Closed
22	Backward Alarm In 1	Input
23	Backward Alarm In 3	Input

5.8.6 ES/ES (J18) Universal Interface

The Earth Station to Earth Station (ES/ES) is a 9 Pin Female 'D' port. Refer to Table 5-23 for pinouts.

Table 5-23. ES/ES Port - 9-Pin Female 'D' Connector (J18)		
Pin No.	Signal Name	Description
1	RXD-B	Receive Data B
6	DSR	Date Set Ready
2	RXD-A	Receive Data A
7	RTS	Request to Send (Pin 7 & 8 Tied Together)
3	TXD-A	Transmit Data A
8	CTS	Clear to Send
4	TXD-B	Transmit Data B
9	NC	No Connection
5	GROUND	Signal Ground

5.8.7 RXB (J30)

Modem B RX Data Port (SD) is a G703 Unbalanced 75-Ohm Female BNC Connector.

5.8.8 TERR RX (J31)

The TERR RX User Data Port is a G703 Unbalanced 75-Ohm Female BNC Connector.

5.8.9 RXA (J32)

Modem A RX Data Port (SD) is a G703 Unbalanced 75-Ohm Female BNC Connector.

5.8.10 TXB (J33)

Modem B TX Data Port (RD) is a G703 Unbalanced 75-Ohm Female BNC Connector.

5.8.11 TERR TX (J34)

The TERR TX User Data Port is a G703 Unbalanced 75-Ohm Female BNC Connector.

5.8.12 TXA (J35)

Modem A TX Data Port (RD) is a G703 Unbalanced 75-Ohm Female BNC Connector.

5.9 High-Speed Serial Interface (HSSI) & ASI or G703 Interface (Optional)

This interface supports HSSI and the G703 or ASI interface. The RCS11 must be configured with either ASI or G703 when ordering. This interface is supported by the DMD20, DMD50, DD240XR and DM240XR Modem.

5.9.1 HSSI TERR DATA (J8)

The HSSI (High-Speed Serial Interface) (J6) complies with the HSSI Functional and Electrical Specifications. The physical interface is a 50-Pin SCSI-2 Type Connector. Electrical levels are ECL. Gapped clocking not supported. The pinouts for this interface are listed in Table 5-24.

Pin No. (+)	Pin No. (-)	Signal Name	Description	Direction
1	26	SG	Signal Ground	---
2	27	RT	Receive Timing	Output
3	28	CA	DCE Available	Output
4	29	RD	Receive Data	Output
6	31	ST	Send Timing (SCT)	Output
7	32	SG	Signal Ground	---
8	33	TA	DTE Available	Input
9	34	TT	Terminal Timing (SCTE)	Input
11	36	SD	Send Data	Input
13	38	SG	Signal Ground	---
14 - 18	39 – 43	5 Ancillary to DCE	Reserved	Input
19	44	SG	Signal Ground	---
20 - 23	45 - 48	4 Ancillary from DCE	Reserved	Output
24	49	TM	Test Mode	Output

5.9.2 ASI or G703 Data Interface

5.9.2.1 TXA ASI or G703 (J15)

Modem A TX Data Port is an ASI or G703 Unbalanced 75-Ohm Female BNC Connector. RCS11 Switch must be ordered supporting either ASI or G703 interface.

5.9.2.2 TERR TX ASI or G703 (J16)

The TERR TX User Data Port is an ASI or G703 Unbalanced 75-Ohm Female BNC Connector. RCS11 Switch must be ordered supporting either ASI or G703 interface.

5.9.2.3 TXB - ASI or G703 (J17)

Modem B TX Data Port (RD) is an ASI or G703 Unbalanced 75-Ohm Female BNC Connector. RCS11 Switch must be ordered supporting either ASI or G703 interface..

5.9.2.4 RXA - ASI or G703 (J18)

Modem A RX Data Port (SD) is an ASI or G703 Unbalanced 75-Ohm Female BNC Connector. RCS11 Switch must be ordered supporting either ASI or G703 interface.

5.9.2.5 TERR RX - ASI or G703 (J19)

The TERR RX User Data Port is an ASI or G703 Unbalanced 75-Ohm Female BNC Connector. RCS11 Switch must be ordered supporting either ASI or G703 interface.

5.9.2.6 RXB - ASI or G.703 (J20)

Modem B RX Data Port (SD) is an ASI or G703 Unbalanced 75-Ohm Female BNC Connector. RCS11 Switch must be ordered supporting either ASI or G703 interface.

5.9.3 FAULTS (J1)

The Fault Port is a 9-Pin Female 'D' Connector for HSSI/G703/ASI interface. The fault connector is configured differently for this interface. Refer to Table 5-25 for pinouts.

Table 5-25. J1 Fault HSSI Interface Only (9-Pin Female 'D')		
Pin No.	Direction	Status
1	Switch Fault Relay	Common
2	Switch Fault Relay	Normally Open
3	Mod Fault A Open Collector	Input
4	Mod Fault B Open Collector	Input
5	Ground	GND
6	Switch Fault Relay	Normally Closed
7	Demod A Fault Open Collector	Input
8	Demod B Fault Open Collector	Input
9	No Connection	NA

* **Note:** Connect to Ground on power up to enable RS485 Mode

5.10 ETHERNET & RS530 DATA INTERFACE

The RCS11 Ethernet Interface supports 10/100/1000 Base-T and RS530/422 Synchronous data. This interface is supported by the the DMD20, DMD50, DM240XR and DD240XR.

5.10.1 EIA 530 (J10)

The EIA-530 is a 25 Pin Female 'D' port. This port is the user interface for Synchronous RS-422 Data. Refer to Table 5-26 for pinouts.

Pin No.	Signal Name	Direction
1	Shield	GND
2	Send Data A (-)	Input
3	Receive Data A (-)	Output
4	Request To Send A (-)	Input
5	Clear To Send A (-)	Output
6	Data Mode A (-)	Output
7	Signal Ground	GND
8	Receiver Ready A (-)	Output
9	Receive Timing B (+)	Output
10	Receiver Ready B (+)	Output
11	Terminal Timing B (+)	Input
12	Send Timing B (+)	Output
13	Clear T Send B (+)	Output
14	Send Data B (+)	Input
15	Send Timing A (-)	Output
16	Receive Data B (+)	Output
17	Receive Timing A (-)	Output
18, 21, 25	NC	NA
19	Request To Send B (+)	Input
20	Data Terminal Ready A (-)	Input
22	Data Mode B (+)	Output
23	Data Terminal Ready B (+)	Input
24	Terminal Timing A (-)	Input

5.10.2 Ethernet Interface

The Ethernet interface can support 10/100/1000 Base-T.

5.10.2.1 DATA B (J27)

Modem B Data Port is an RJ45 Connector.

5.10.2.2 TERR DATA (J28)

The TERR TX User Data Port is an RJ45 Connector.

5.10.2.3 DATA A (J29)

Modem A Data Port is an RJ45 Connector.

5.10.2.4 SWITCH (S1)

The RCS11 Ethernet interface can be configured to support a modem or Modulator/Demodulator. The S1 switch must be properly set to the correct position to support the modem or Modulator/Demodulator.

NOTE: On the S1 Switch moving the switch to the left sets the unit to the Modem Feature, moving the switch to the right sets the unit to the Mod/Demod Feature.

NOTE: Power must be cycled after changing S1 to desired setting for effect to take place.

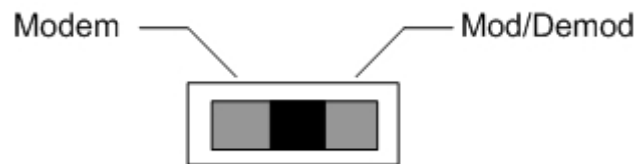

Figure 5-2. RCS11 S1 Switch Diagram

5.11 SERIAL INTERFACE

The RCS11, RS449 Serial Interface supports RS422 Serial Data. This interface is supported by the the DMD20 and DMD50.

5.11.1 TERRESTRIAL RS449/RS422 SERIAL DATA (J10)

The Terrestrial Data (J10) is a 37-Pin Female 'D' port. Refer to Table 5-27 for pinouts.

Table 5-27. J10 TERRESTRIAL DATA		
Pin Number	Description	Signal
1,19,20,37	Ground	GND
2,10,12,14,18,28,30,32,34,36	Not Used	NA
3	Transmit Octet (A) -	Input
4	Send Data (A) -	Input
5	Send Timing (A) -	Output
6	Receive Data (A) -	Output
7	Request To Send (A) -	Input
8	Receive Timing (A) -	Output
9	Clear To Send (A) -	Output
11	Data Mode (A) -	Output
13	Receive Ready (A) -	Output
15	External Clock (A) -	Input
16	Receive Octet (A) -	Output
17	Terminal Timing (A) -	Input
21	Transmit Octet (B) +	Input
22	Send Data (B) +	Input
23	Send Timing (B) +	Output
24	Receive Data (B) +	Output
25	Request To Send (B) +	Input
26	Receive Timing (B) +	Output
27	Clear To Send (B) +	Output
29	Data Mode (B) +	Output
31	Receive Ready (B) +	Output
33	External Clock (B) +	Input
34	Receive Octet (B) +	Output
35	Terminal Timing (B) +	Input

5.11.2 DATA A & B (J7 & J11)

The RS449/422 Data ports are 37-Pin Female 'D' ports. These ports are the interface connection between the modem and the RCS11 Switch. Refer to Table 5-28 for pinouts.

Table 5-28. J7 (Modem A) /J11 (Modem B) RS449/RS422 Data Interface Modem A and Modem B Connector Pin Assignment		
Pin #	Signal Name	Direction
1	Shield	
3	External FIFO Buffer Output Clock (A) -	Output
4	Transmit Data (A) -	Output
5	Transmit Clock (A) -	Input
6	Receive Data (A) -	Input
7	RTS (A) -	Output
8	Receive Clock (A) -	Input
9	CTS (A) -	Input
11	Data Mode (A) -	Input
12	DTR (A) -	Output
13	Receive Ready (A) -	Input
14	Mod Fault Alarm	OC TTL Input
17	Terminal Timing (A) -	Output
19	Signal GND	GND
20	Common	GND
21	External FIFO Buffer Output Clock (B) +	Output
22	Transmit Data (B) +	Output
23	Transmit Clock (B) +	Input
24	Receive Data (B) +	Input
25	RTS (B) +	Output
26	Receive Clock (B) +	Input
27	CTS (B) +	Input
29	Data Mode (B) +	Input
30	DTR (B) +	Output
31	Receive Ready (B) +	Input
33	Demod Fault Alarm	OC TTL Input
35	Terminal Timing (B) +	Output

Chapter 6. Maintenance and Troubleshooting

6.1 Basic Troubleshooting and Maintenance

This section provides information on the basic troubleshooting and repair procedures for the RCS11 1:1 Switch that may be performed on-site by qualified personnel. Only minor repairs will be discussed. For serious failures, the user should not attempt to repair the unit without first contacting the Comtech EF Data Customer Service Department at 480-333-4357 for further information and instructions.

6.2 Basic User Checks

Upon the detection of an operational failure, the source of the failure must be determined. Basic user checks include checking the power line fuses, and the various cables and connectors.

6.2.1 Checking the Fuses



High voltage is present on the power supply heat sinks when the power supply is energized. Use extreme caution when removing the RCS11 top cover when the unit is powered up. Do not touch the top cover on any of the internal components during removal or replacement.



The appropriate AC power cord must be disconnected before the fuse may be removed. To keep the RCS11 operational, be sure to disconnect only one power cord at a time. Also be sure to replace the fuse and the power cord before checking the other fuse.

The AC fuses are located at the front of the RCS11 on the Power Supply Boards inside the unit. Test the fuse with an Ohmmeter or similar device. If necessary, replace the fuse with a new one of the same size and rating. Failure to do so may result in damage to the equipment, void the warranty, and may result in a fire hazard.

6.2.2 Checking the Cabling and Connectors

Problems that appear difficult to solve can often be traced to a loose or defective cable or connector. The user should first verify the following:

- All cables within the system have no broken or loose connections. Cables that are suspect should be replaced.
- All jacks on the units have no bent or broken pins.
- Both AC Power Cords are properly plugged into the rear of the RCS11.

6.3 Major and Minor Faults

Major faults are failure conditions or combinations of conditions that result in loss of service on one or more channels. Minor faults are failure conditions that do not result in loss of service.

Possible Major Fault conditions are:

A Read-Only Memory (ROM) failure in the Switch;
 A Random Access Memory (RAM) failure in the Switch;
 A loss of Carrier Detect on a Demodulator Channel where this attribute is monitored;
 A loss of Terrestrial Input Clock on a Channel where this attribute is monitored;
 A failure of two monitored Modulators;
 A failure of two monitored DeModulators;
 A failure of both RCS11 power supplies.

Possible Minor Fault conditions are as follows:

A failure of one of the Switch's two redundant power supplies;
 A failure of one Demodulator that is being monitored (i.e., a Demodulator that has not been locked out);
 A failure of one Modulator that is being monitored;
 A reference clock slip.

Chapter 7. Technical Specifications

7.1 Introduction

This section defines the technical performance parameters and specifications for the RCS11 1:1 Redundancy Switch.

7.2 General

Modes of Operation:	Auto, Manual, Remote
Configurations:	Modem, Mod Only, Demod Only
Modulator Switch Time:	50 msec Maximum
Demodulator Switch Time:	50 msec Maximum + □ Demod Lock Time
Modulator Switch Delay Time:	40 msec
Demodulator Switch Delay Time:	1 Second
IF Switching:	<u>70/140 MHz</u> : BNC (F) 75 Ohm Standard (50 Ohm Optional) <u>L-Band</u> : SMA (F) All L-Band Products

7.3 Monitor and Control

All operating parameters can be monitored and controlled via the front panel display/keypad or the RS-485 or RS-232 serial control channel in either terminal or command modes. The following modem parameters may be controlled and/or monitored:

Parameters Monitored:	Mode, Mod/Demod/Modem, Power Supply Status, Internal Switch Settings, Software Revision, Auto/Manual, Select A, Select B
Parameters Controlled:	Mode, Mod/Demod/Modem, Auto/Manual, Select A, Select B

7.4 Terrestrial Interfaces

DMD15:	<u>Universal</u> : RS449/V.35/RS232/G.703 Bal & Unbal/ IDR & IBS Alarms/Drop & Insert
DM240XR:	ASI, M2P, DVB (RS422 or LVDS), HSSI, <u>Ethernet</u> : 100/1000 Base-T/RS-530
DD240XR:	<u>Synch</u> : ASI or ASI with offline IFMonitor or RS530 <u>Universal</u> : M2P, DVB (RS-422 or LVDS), <u>Universal</u> : G703 (T3, E3, STS1) / HSSI <u>Ethernet</u> : Ethernet 100/1000 Base-T/RS-530

DMD20:	<u>Synch</u> : RS530/ V.35/RS232 <u>Universal</u> : RS530/V.35/RS232/G.703/IDR & IBS Alarms/Drop & Insert, ASI/Parallel, HSSI, <u>Ethernet</u> : 10/100 Base-T/RS530
DMD50:	<u>Synch</u> : RS530/ V.35/RS232 <u>Universal</u> : RS530/V.35/RS232/G.703/ IDR & IBS Alarms/Drop & Insert, <u>Universal</u> : G703 (T3, E3, STS1) / HSSI <u>Universal</u> : ASI
DMD2050:	Ethernet 10/100 Base-T/RS530 <u>Synch</u> : RS530/ V.35/RS232 (MIL-188-144) <u>Universal</u> : RS530/V.35/RS232/G.703/ IDR & IBS Alarms/Drop & Insert, <u>Universal</u> : G703 (T3, E3, STS1) / HSSI <u>Universal</u> : ASI Ethernet 10/100 Base-T/RS530

7.5 Front Panel LED Indicators

Unit:	Power Supply 1 Power Supply 2 Switch Fault Auto Manual
Demodulator: Fault A/B	Online A/B
Modulator: Fault A/B	Online A/B
	Front Panel Controls Enable Select Auto Mod Select A Mod Select B Demod Select A Demod Select B

7.6 Power and Environmental

Prime Power:	100 to 240 VAC, 50 to 60 Hz, 40 Watts
Operating Temperature:	0 to 50°C, 95% Humidity, Noncondensing

7.7 Storage Temperature: -20 to 70°C, 99% Humidity, Noncondensing Physical

Chassis Size Long:	21.75" L x 19" W x 1.75" H (55.24 cm x 48.26 cm x 4.45 cm) 9 Pounds (4.08 Kg)
Chassis Size Short:	16.5" L x 19" W x 1.75" H (41.91 cm x 48.26 cm x 4.45 cm) 8 Pounds (3.62 Kg)

Appendix A. RCS11 DIP Switch Configuration

The RCS11 has four internal DIP switches that are accessible only by removing the top cover. These DIP switches S2, S3, S4 & S5 are used to configure Interface options, data rates and remote baud rates. An upgrade or change from an existing interface or configuration to another may require a change to one or more of the DIP switch settings. If you are having trouble with DIP switch settings, contact Radyne Customer Service for any additional help.

Figure A-1 Illustrates the DIP switch positions for the various Radyne product types.
 Figure A-2 Illustrates the unit Addressing for and Baud Rate switch positions for remote M&C.

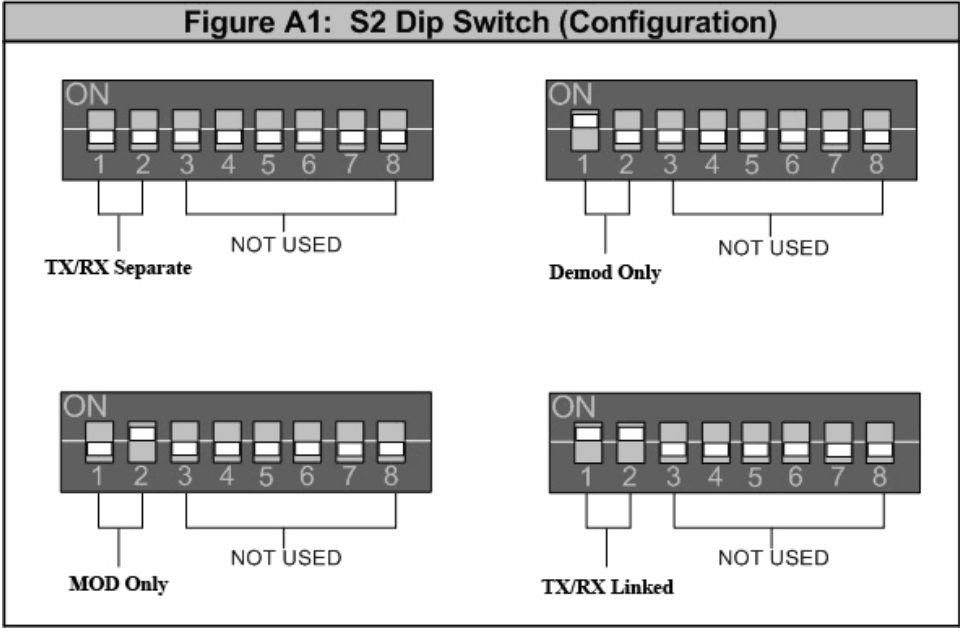

Figure A-1. DIP Switch Positions for the Different Radyne Devices

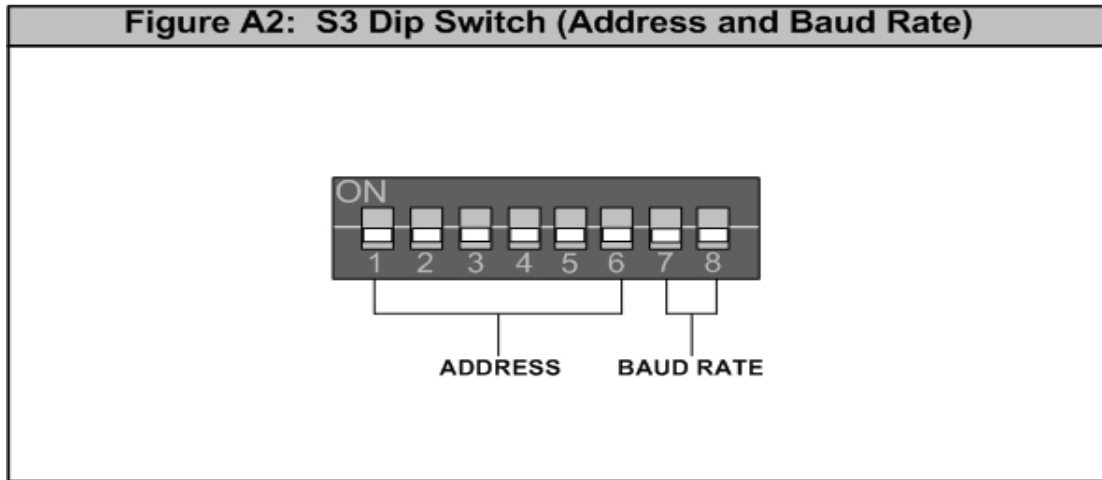

Figure A-2. DIP Switch showing Address and Baud Rate

Table A-1 identifies the various S3 dip switch positions. Pins 1 - 6 are utilized for M&C unit addressing when using multiple switches. Pins 7 & 8 are utilized for baud rate for the terminal or remote M&C. Address settings are also accessible through the Remote Port (J-20) with the switch in Terminal Mode. An empty space in Table A-1: represents the (off) position.

Table A-1. Baud Rate Switch Positions								
BAUD RATE	SW-1	SW-2	SW-3	SW-4	SW-5	SW-6	SW-7	SW-8
9600								
4800							ON	
2400								ON
ADDRESS								
32								
33	ON							
34		ON						
35	ON	ON						
36			ON					
37	ON		ON					
38		ON	ON					
39	ON	ON	ON					
40				ON				
41	ON			ON				
42		ON		ON				
43	ON	ON		ON				
44			ON	ON				
45	ON		ON	ON				
46		ON	ON	ON				
47	ON	ON	ON	ON				
48					ON			
49	ON				ON			
50		ON			ON			
51	ON	ON			ON			
52			ON		ON			
53	ON		ON		ON			
54		ON	ON		ON			
55	ON	ON	ON		ON			
56				ON	ON			
57	ON			ON	ON			
58		ON		ON	ON			
59	ON	ON		ON	ON			
60			ON	ON	ON			
61	ON		ON	ON	ON			
62		ON	ON	ON	ON			
63	ON	ON	ON	ON	ON			
64						ON		
65	ON					ON		
66		ON				ON		
67	ON	ON				ON		

68			ON			ON		
69	ON		ON			ON		
70		ON	ON			ON		
71	ON	ON	ON			ON		
72				ON		ON		
73	ON			ON		ON		
74		ON		ON		ON		
75	ON	ON		ON		ON		
76			ON	ON		ON		
77	ON		ON	ON		ON		
78		ON	ON	ON		ON		
79	ON	ON	ON	ON		ON		
80					ON	ON		
81	ON				ON	ON		

Table A-1 Continued

82		ON			ON	ON		
83	ON	ON			ON	ON		
84			ON		ON	ON		
85	ON		ON		ON	ON		
86		ON	ON		ON	ON		
87	ON	ON	ON		ON	ON		
88				ON	ON	ON		
89	ON			ON	ON	ON		
90		ON		ON	ON	ON		
91	ON	ON		ON	ON	ON		
92			ON	ON	ON	ON		
93	ON		ON	ON	ON	ON		
94		ON	ON	ON	ON	ON		
SOFT	ON	ON	ON	ON	ON	ON		



IMPORTANT

When Jumpers are set for SOFT, this allows user to set the Baud and Unit Addresses remotely via the terminal port.



IMPORTANT

For RS485 Remote communication, install CA/3733 gender changer into the remote port. Gender changes port from RS232 to RS485

Figure A-3 Illustrates how to configure the Dip Switches for RS232 Data on an RCS11 with Universal Data Interface.

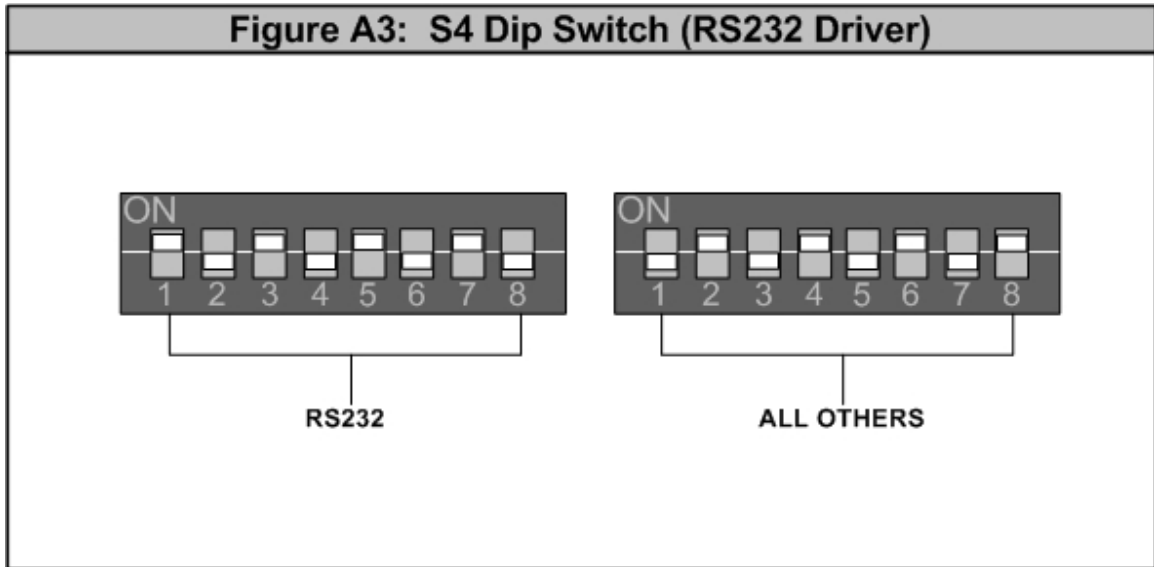

Figure A-3. DIP Switch on the RS232 Driver

Figure A-4 Illustrates how to configure the Dip Switches for G.703 Unbalanced data on an RCS11 with Universal Data Interface.

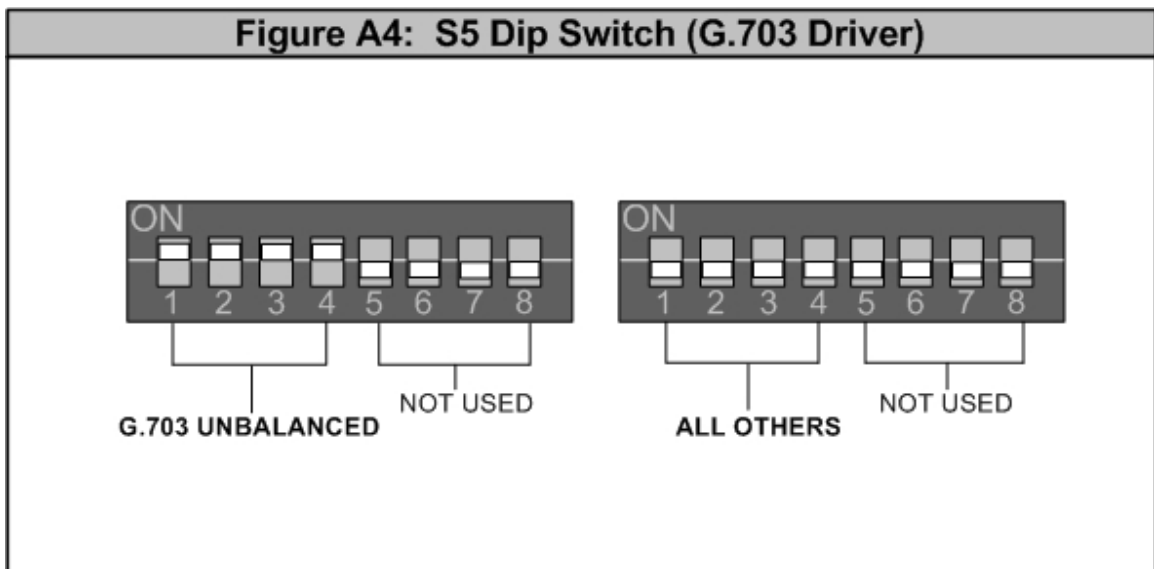

Figure A-4. DIP Switch on the G.703 Driver

Figure A-5 Illustrates standard jumper blocks for fault execution on all Radyne products. J4 and JP1 Shunt Blocks should be installed as a factory default configuration.

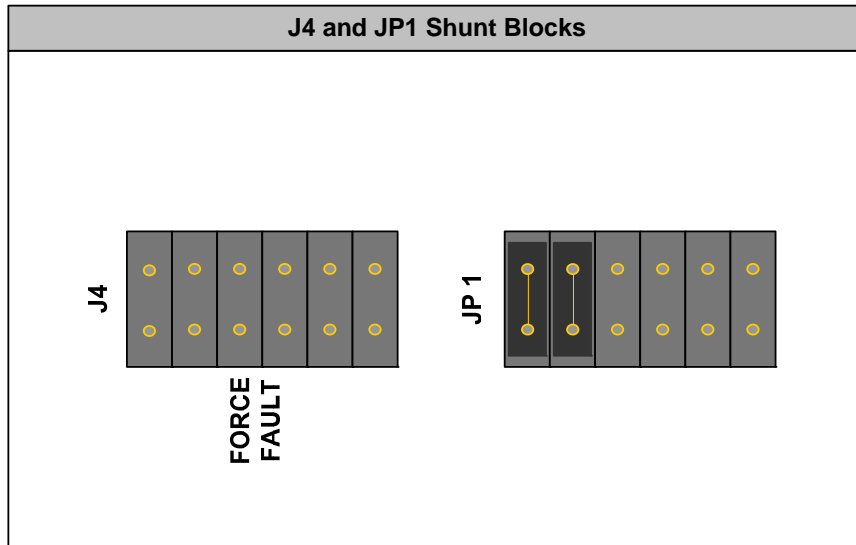

Figure A-5. J4 and JP1 Shunt Blocks

Appendix B. RCS11 Remote Communications

B.1 Host Computer Remote Communications

Control and status messages are conveyed between the RCS11 and the host computer using packetized message blocks in accordance with a proprietary communications specification. This communication is handled by the Radyne Link Level Protocol (RLLP), which serves as a protocol 'wrapper' for the RM&C data.

Complete information on monitor and control software is contained in the Radyne RLLP Protocol Reference Guide.



IMPORTANT

For RS485 Remote communication, install CA/3733 gender changer into the remote port. Gender changes port from RS232 to RS485

B.1.1 Protocol Structure

The Communications Specification (COMMSPEC) defines the interaction of computer resident Monitor and Control software used in satellite earth station equipment such as Modems, redundancy switches, multiplexers, and other ancillary support gear. Communication is bi-directional, and is normally established on one or more full-duplex 9600-baud multi-drop control buses that conform to EIA Standard RS-485.

Each piece of earth station equipment on a control bus has a unique physical address, which is assigned during station setup/configuration or prior to shipment. Valid decimal addresses on one control bus range from 032 through 255 for a total of up to 224 devices per bus. Address 255 of each control bus is usually reserved for the M&C computer.

B.1.2 Protocol Wrapper

The Radyne COMMSPEC is byte-oriented, with the Least Significant Bit (LSB) issued first. Each data byte is conveyed as mark/space information with two marks comprising the stop data. When the last byte of data is transmitted, a hold comprises one steady mark (the last stop bit). To begin or resume data transfer, a space (00h) substitutes this mark. This handling scheme is controlled by the hardware and is transparent to the user. A pictorial representation of the data and its surrounding overhead may be shown as follows:

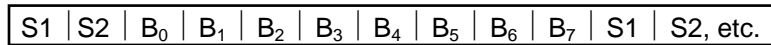

The stop bits, S1 and S2, are each a mark. Data flow remains in a hold mode until S2 is replaced by a space. If S2 is followed by a space, it is considered a start bit for the data byte and not part of the actual data (B₀ - B₇).

The COMMSPEC developed for use with the Radyne Link Level Protocol (RLLP) organizes the actual monitor and control data within a shell, or 'protocol wrapper', that surrounds the data. The format and structure of the COMMSPEC message exchanges are described herein. Decimal numbers have no suffix; hexadecimal numbers end with a lower case h suffix and binary values have a lower case b suffix. Thus, 22 = 16h = 000010110b. The principal elements of a data frame, in order of occurrence, are summarized as follows:

<SYN> - the message format header character, or ASCII sync character, that defines the beginning of a message. The <SYN> character value is always 16h.

<DATA COUNT> - the 2 Byte Data Count is the number of bytes in the <DATA> field, ranging from 0 through 509.

<SOURCE ID> - the Source Identifier defines the multi-drop address origin. Note that all nodes on a given control bus have a unique address that must be defined.

<DESTINATION ID> - the Destination Identifier serves as a pointer to the multi-drop destination device that indicates where the message is to be sent.

<FRAME SEQUENCE NUMBER> -the FSN is a tag with a value from 0 through 255 that is sent with each message. It assures sequential information framing and correct equipment acknowledgment and data transfers.

<OPCODE> - the 2 Byte Operation Code field contains a number that identifies the message type associated with the data that follows it. Equipment under MCS control recognizes this byte via firmware identification and subsequently steers the DATA accordingly to perform a specific function or series of functions. Acknowledgment and error codes are returned in this field. 1 Byte for the DMD5000 protocol and 2 Bytes for the DMD15 protocol.

<DATA > - the Data field contains the binary, bi-directional data bytes associated with the <OPCODE> - The number of data bytes in this field is indicated by the <BYTE COUNT> value.

<CHECKSUM> - the checksum is the modulo 256 sum of all preceding message bytes, excluding the <SYN> character. The checksum determines the presence or absence of errors within the message. In a message block with the following parameters, the checksum is computed as shown in Table 1.

<u>BYTE FIELD</u>	<u>DATA CONTENT</u>	<u>RUNNING CHECKSUM</u>
<BYTE COUNT>	02h = 00000000b	00000000b
<BYTE COUNT>	02h = 00000010b	00000010b

<SOURCEID>	F0h	= 11110000b	11110010b
<DESTINATION ID>	2Ah	= 00101010b	00011100b
<FSN>	09h	= 00001001b	00100101b
<OPCODE>	03h	= 00000011b	00101000b
<DATA> (Byte 1)	DFh	= 11011111b	00000111b
<DATA> (Byte 2)	FEh	= 11111110b	00000101b

Table 1. Checksum Calculation Example

Thus, the checksum is 00000101b; which is 05h or 5 decimal. Alternative methods of calculating the checksum for the same message frame are:

$$02h + F0h + 2Ah + 09h + 03h + DFh + FEh = 305h.$$

Since the only concern is the modulo 256 (modulo 1 00h) equivalent (values that can be represented by a single 8-bit byte), the checksum is 05h.

For a decimal checksum calculation, the equivalent values for each information field are:
 $0 + 2 + 240 + 42 + 9 + 3 + 223 + 254 = 773$; $773/256 = 3$ with a remainder of 5.

This remainder is the checksum for the frame.
 5 (decimal) = $05h = 0101b = <CHECKSUM>$

B.1.3 Frame Description and Bus Handshaking

In a Monitor and Control environment, every message frame on a control bus port executes as a packet in a loop beginning with a wait-for-SYN-character mode. The remaining message format header information is then loaded, either by the M&C computer or by a subordinate piece of equipment (such as the DMD15) requesting access to the bus. Data is processed in accordance with the OPCODE, and the checksum for the frame is calculated.

If the anticipated checksum does not match then a checksum error response is returned to the message frame originator. The entire message frame is discarded and the wait-for-SYN mode goes back into effect. If the OPCODE resides within a command message, it defines the class of action that denotes an instruction which is specific to the device type, and is a prefix to the DATA field if data is required. If the OPCODE resides within a query message packet, then it defines the query code, and can serve as a prefix to query code DATA.

The Frame Sequence Number (FSN) is included in every message packet, and increments sequentially. When the M & C computer or bus-linked equipment initiates a message, it assigns the FSN as a tag for error control and handshaking. A different FSN is produced for each new message from the FSN originator to a specific device on the control bus. If a command packet is sent and not received at its intended destination, then an appropriate response message is not received by the packet originator. The original command packet is then re-transmitted with the same FSN. If the repeated message is received correctly at this point, it is considered a new message and is executed and acknowledged as such.

If the command packet is received at its intended destination but the response message (acknowledgment) is lost, then the message originator (usually the M&C computer) re-transmits the original command packet with the same FSN. The destination device detects the same FSN and recognizes that the message is a duplicate, so the associated commands within the packet are not executed a second time. However, the response packet is again sent back to the source as an acknowledgment in order to preclude undesired multiple executions of the same command.

To reiterate, valid equipment responses to a message require the FSN tag in the command packet. This serves as part of the handshake/acknowledge routine. If a valid response message is absent, then the command is re-transmitted with the same FSN. For a repeat of the same command involving iterative processes (such as increasing or decreasing the transmit power level of a DMD15 modulator), the FSN is incremented after each message packet. When the FSN value reaches 255, it overflows and begins again at zero. The FSN tag is a powerful tool that assures sequential information framing, and is especially useful where commands require more than one message packet.

The full handshake/acknowledgment involves a reversal of source and destination ID codes in the next message frame, followed by a response code in the <OPCODE> field of the message packet from the equipment under control.

If a command packet is sent and not received at its intended destination, a timeout condition can occur because a response message is not received by the packet originator. On receiving devices slaved to an M & C computer, the timeout delay parameters may be programmed into the equipment in accordance with site requirements by Radyne Corp. prior to shipment, or altered by qualified personnel. The FSN handshake routines must account for timeout delays and be able to introduce them as well.

B.1.4 Global Response Operational Codes

In acknowledgment (response) packets, the operational code <OPCODE> field of the message packet is set to 0 by the receiving devices when the message intended for the device is evaluated as valid. The device that receives the valid message then exchanges the <SOURCE ID> with the <DESTINATION ID>, sets the <OPCODE> to zero in order to indicate that a good message was received, and returns the packet to the originator.

This "GOOD MESSAGE" opcode is one of nine global responses. Global response opcodes are common responses, issued to the M&C computer or to another device that can originate from and are interpreted by all Radyne equipment in the same manner. These are summarized as follows (all opcode values are expressed in decimal form):

RESPONSE OPCODE DESCRIPTION	OPCODE
Good Message	000
Bad Parameter	255
Bad Opcode	254
Bad Checksum	253
Command Not Allowed in LOCAL Mode	252
Command Not Allowed in AUTO Mode	251
Bad Destination	250
Unable to Process Command	249
Packet Too Long	248

Table 2. Response OPCODES

B.1.5 Software Compatibility



The DMD15 RLLP is not software-compatible with the following previous Radyne products: RCU5000 and DMD4500. These products may not occupy the same bus while using this protocol as equipment malfunction and loss of data may occur.

The COMMSPEC, operating in conjunction within the RLLP shell, provides for full forward and backward software compatibility independent of the software version in use. New features are appended to the end of the DATA field without OPCODE changes. Older software simply discards the data as extraneous information without functional impairment for backward compatibility.

If new device-resident or M&C software receives a message related to an old software version, new information and processes are not damaged or affected by the omission of data.

The implementation of forward and backward software compatibility often, but not always, requires the addition of new Opcodes. Each new function requires a new Opcode assignment if forward and backward compatibility cannot be attained by other means.

B.1.6 RLLP Summary

The RLLP is a simple send-and-wait protocol that automatically re-transmits a packet whenever an error is detected, or when an acknowledgment (response) packet is absent.

During transmission, the protocol wrapper surrounds the actual data to form information packets. Each transmitted packet is subject to time out and frame sequence control parameters, after which the packet sender waits for the receiver to convey its response. Once a receiver verifies that a packet sent to it is in the correct sequence relative to the previously received packet, it computes a local checksum on all information within the packet excluding the <SYN> character and the <CHECKSUM> fields. If this checksum matches the packet <CHECKSUM>, the receiver processes the packet and responds to the packet sender with a valid response (acknowledgment) packet. If the checksum values do not match, the receiver replies with a negative acknowledgment (NAK) in its response frame.

The response packet is therefore either an acknowledgment that the message was received correctly, or some form of a packetized NAK frame. If the sender receives a valid acknowledgment (response) packet from the receiver, the <FSN> increments and the next packet is transmitted as required by the sender. However, if a NAK response packet is returned the sender re-transmits the original information packet with the same embedded <FSN>.

If an acknowledgment (response) packet or a NAK packet is lost, corrupted, or not issued due to an error and is thereby not returned to the sender, the sender re-transmits the original information packet; but with the same <FSN>. When the intended receiver detects a duplicate packet, the packet is acknowledged with a response packet and internally discarded to preclude undesired repetitive executions. If the M&C computer sends a command packet and the corresponding

response packet is lost due to a system or internal error, the computer times out and re-transmits the same command packet with the same <FSN> to the same receiver and waits once again for an acknowledgment or a NAK packet.

To reiterate, the format of the message block is shown in below in Table 3, Link Level Protocol Message Block.

SYNC	COUNT	SRC ADDR	DEST ADDR	FSN	OP CODE	DATA BYTES	CHECKSUM
------	-------	----------	-----------	-----	---------	------------	----------

Table 3. Link Level Protocol Message Block

B.2 Remote Port Packet Structure:

The RCS11 protocol is an enhancement on the DMD5000 protocol. It also uses a packet structure format. The structure is as follows:

<SYNC>	=	Message format header character that defines the beginning of a message. The <SYNC> character value is always 0x16. (1 byte)
<BYTE COUNT>	=	Number of bytes in the <DATA> field. (2 bytes)
<SOURCE ID>	=	Identifies the address of the equipment from where the message originated. (1 byte)
<DEST. ID>	=	Identifies the address of the equipment where the message is to be sent. (1 byte)
<F.S.N.>	=	Frame sequence number insures correct packet data transfers. (1 byte)
<OPCODE>	=	This byte identifies the message type associated with the information data. The equipment processes the value in this field. Return error codes and acknowledgment are also included in this field. (2 bytes)
<...DATA...>	=	Information data. The number of data bytes in this field is indicated by the <BYTE COUNT> value.
<CHECKSUM>	=	The modulo 256 sum of all preceding message bytes excluding the <SYNC> character. (1 byte)



The DMD15 RLLP is not software-compatible with the following previous Radyne products: RCU5000 and DMD4500. These products may not occupy the same bus while using this protocol as equipment malfunction and loss of data may occur.

**IMPORTANT**

When transmitting a packet at 9600 baud, the Remote M&C should ensure that the timeout value between characters does not exceed the time it takes to transmit 200 characters (≈ 200 msec). If this timeout value is exceeded, the equipment will timeout.

Regular Commands

Opcode <2000h> Query RCS11 Device Identification

Query Response Data Field (1 byte):

<1> Device Identification 26 decimal for RCS11

Opcode <2080h> Query RCS11 Device Firmware Version

Query Response Data Field (19 bytes):

<1> Device Firmware Version MSB binary number, implied decimal point
 <1> Device Firmware Version LSB binary number, implied decimal point
 <10> Device Firmware Name null terminated string
 <7> Device Firmware Release Date null terminated string

Opcode <2280h> Command RCS11 Load Factory Defaults

Command Data Field (2 bytes):

<1> Unlock Code 1 0x55
 <1> Unlock Code 2 0xAA

Opcode <2083h> Query RCS11 Backup Configuration

Query Response Data Field (1 byte):

<1> Backup Configuration 0 = Modem (Coupled)
 1 = Mod Only
 2 = Demod Only
 3 = Mod/Demod (Uncoupled)

Opcode <2084h> Query RCS11 Backup Mode

Query Response Data Field (1 byte):

<1> Backup Mode 0 = Manual
 1 = Automatic
 2 = <unknown>

Opcode <2284h> Command RCS11 Backup Mode

Command Data Field (1 byte):

<1> Backup Mode 0 = Manual
 1 = Automatic

Opcode <2085h> Query RCS11 Backup State

Query Response Data Field (2 bytes):

<1> Mod Backup state 0 = A online
 1 = B online
 2 = <none or unknown>

<1> Demod Backup State 0 = A online

1 = B Online
2 = <none or unknown>

Opcode <2285h> Command RCS11 Force Manual Backup

Command Data Field (2 bytes):

<1> Mod Backup State 0 = A online
1 = B online
<1> Demod Backup State 0 = A online
1 = B online

Opcode <2086h> Query RCS11 Switch Delays

Query Response Data Field (8 Bytes):

<1> Switch Delay Mod Fault MSB
<1> Switch Delay Mod Fault LSB
<1> Switch Delay Mod NoFault MSB
<1> Switch Delay Mod NoFault LSB
<1> Switch Delay Demod Fault MSB
<1> Switch Delay Demod Fault LSB
<1> Switch Delay Demod NoFault MSB
<1> Switch Delay Demod NoFault LSB

Opcode <2286h> Command RCS11 Switch Delays

Command Data Field (8 Bytes):

<1> Switch Delay Mod Fault MSB
<1> Switch Delay Mod Fault LSB
<1> Switch Delay Mod NoFault MSB
<1> Switch Delay Mod NoFault LSB
<1> Switch Delay Demod Fault MSB
<1> Switch Delay Demod Fault LSB
<1> Switch Delay Demod NoFault MSB
<1> Switch Delay Demod NoFault LSB

Opcode <2087h> Query RCS11 Switch Alarms

Query Response Data Field (5 bytes):

<1> Global Current Alarm Bit 0: 1 = Global Alarm
Bit 1..7: unused, return 0

<1> External Current Alarms
Bit 0: 1 = Mod A Alarm
Bit 1: 1 = Force Mod A Alarm
Bit 2: 1 = Demod A Alarm
Bit 3: 1 = Force Demod A Alarm
Bit 4: 1 = Mod B Alarm
Bit 5: 1 = Force Mod B Alarm
Bit 6: 1 = Demod B Alarm
Bit 7: 1 = Force Demod B Alarm

<1> Switch Current Alarms
Bit 0: 1 = Switch Power 1 Alarm
Bit 1: 1 = Switch Power 2 Alarm
Bit 2: 1 = Switch Firmware Alarm
Bit 3: 1 = Switch NV Alarm
Bit 4: 1 = Switch Internal Alarm
Bit 5..7: unused, return 0

<2> Spare Current Alarms Always 0

Opcode: <2089h> Query RCS11 Switch Alarms Mask

Query Response Data Field (4 Bytes):

<1> External Alarm Masks 1 = Enabled, 0 = Masked Off
 Bit 0: 1 = Mod A Alarm Enabled
 Bit 1: 1 = Force Mod A Alarm Enabled
 Bit 2: 1 = Demod A Alarm Enabled
 Bit 3: 1 = Force Demod A Alarm Enabled
 Bit 4: 1 = Mod B Alarm Enabled
 Bit 5: 1 = Force Mod B Alarm Enabled
 Bit 6: 1 = Demod B Alarm Enabled
 Bit 7: 1 = Force Demod B Alarm Enabled

<1> Switch Alarm Masks 1 = Enabled, 0 = Masked Off
 Bit 0: 1 = Switch Power 1 Alarm Enabled
 Bit 1: 1 = Switch Power 2 Alarm Enabled
 Bit 2: 1 = Switch Firmware Error Enabled
 Bit 3: 1 = Switch NV Alarm
 Bit 4: 1 = Switch Internal Alarm Enabled
 Bit 5..7: unused, return 0

<2> Spare Current Alarms Always 0

Opcode: <2289h> Command RCS11 Switch Alarms Masks

Command Data Field (4 Bytes):

<1> External Alarm Masks 1 = Enabled, 0 = Masked Off
 Bit 0: 1 = Mod A Alarm Enabled
 Bit 1: 1 = Force Mod A Alarm Enabled
 Bit 2: 1 = Demod A Alarm Enabled
 Bit 3: 1 = Force Demod A Alarm Enabled
 Bit 4: 1 = Mod B Alarm Enabled
 Bit 5: 1 = Force Mod B Alarm Enabled
 Bit 6: 1 = Demod B Alarm Enabled
 Bit 7: 1 = Force Demod B Alarm Enabled

<1> Switch Alarm Masks 1 = Enabled, 0 = Masked Off
 Bit 0: 1 = Switch Power 1 Alarm Enabled
 Bit 1: 1 = Switch Power 2 Alarm Enabled
 Bit 2: 1 = Switch Firmware Error Enabled
 Bit 3: 1 = Switch NV Alarm Enabled
 Bit 4: 1 = Switch Internal Alarm Enabled
 Bit 5..7: unused, 0 filled

<2> Spare Current Alarms 0 filled

Appendix C. Terminal Communications

The RCS11 support Terminal communications. If the RCS11 is connected to a terminal (using a null modem cable) upon power up you should receive the following text:

If the RCS11 is connected to a terminal (using a null modem cable) upon power up you should receive the following text:

```
RCS11 1:1 Redundancy Switch
Copyright (c) 1996, 1997
Radyne
```

At the terminal screen you will receive a prompt: >_

Typing "help" and pressing <Enter> will cause the RCS11 to output a list of queries and commands

```
>help
ADDR[<=nn>|<?>]
BAUD[<=nn>|<?>]
DELAYDF[<nnnn>|<?>]
DELAYDN[<nnnn>|<?>]
DELAYMF[<nnnn>|<?>]
DELAYMN[<nnnn>|<?>]
DMD[<=A>|<=B>|<?>]
HELP
MOD[<=A>|<=B>|<?>]
MODE[<=AUTO>|<=MANUAL>|<?>]
STATUS
VER
>
```

Typing a command followed by a question mark will cause the RCS11 to output its current setting

```
>addr?
ADDR=32
>
>baud?
```

```
BAUD=9600
>
>delaydf?
DELAYDF=50
>
>delaydn?
DELAYDN=50
>
>delaymf?
  DELAYMF=2
  >
  >delaymn?
  DELAYMN=2
  >
  >dmd?
  DMD=A
  >
  >mod?
  MOD=A
  >
  >mode?
  MODE=MANUAL
  >
```

Typing a command without additional parameters or miss spelling of the command will return an error message

```
>baud
Error: BAD ARGUMENT
>
>staus
Error: BAD COMMAND
>
```

Queries Help, Status and Ver are typed without addition parameters

```
>status

STATUS REPORT

OPERATING MODE
  MOD=A  DMD=A  MODE=MANUAL

COMMUNICATION
  BAUD RATE=9600  REMOTE ADDR= 32 <0x20>

SWITCH SETTINGS
  CONFIG1=0xff  CONFIG2=0xfe  ADDRBAUD=0xff

DELAYS
  DELAYMF=2
  DELAYMN=2
  DELAYDF=50
  DELAYDN=50

>
```

```
>ver
```

```
RCS11 1:1 Redundancy Switch  
Copyright (c) 1996, 1997 Radyne  
Firmware: fw03458-E Release Date: 102797 Version: 01.05
```

```
>
```

The commands ADDR=nn and BAUD=nn are dependent on internal dip switches being set to Soft. If the dip switches are not set to soft the following error will occur:

```
>baud=4800  
Error: BAUD RATE IS HARD CONFIGURED  
>  
>addr=55  
Error: REMOTE ADDRESS IS HARD CONFIGURED  
>
```

When a command is issued with valid parameters it will be followed by the command prompt (no error message)

```
>delaydf=5  
>  
>mod=a  
>  
>dmd=b  
>
```

DELAYDF = demod fault delay. The value is amount of ticks that will occur before the RCS11 considers a demod fault a true fault. A tick is equal to 20m seconds.

DELAYDN = demod non-fault delay. The value is the amount of ticks that will occur before the RCS11 considers a demod as not faulted. If a demod faults and recovers before the demod fault delay then the RCS11 will start counting for the demod non fault delay.

DELAYMF = mod fault delay. The value is amount of ticks that will occur before the RCS11 considers a mod fault a true fault.

DELAYMN = mod non-fault delay. The value is the amount of ticks that will occur before the RCS11 considers a mod as not faulted. If a mod faults and recovers before the mod fault delay then the RCS11 will start counting for the mod non fault delay.

DMD = demod. The value is the online unit. If you want to perform a manual backup of demod A then you would enter "dmd=b". This will cause the RCS11 to put demod B on line.

MOD = mod. The value is the online unit. If you want to perform a manual backup of mod A then you would enter "mod=b". This will cause the RCS11 to put mod B on line.

MODE = switching mode. Entering the command "mode=auto" will set the RCS11 to auto switching mode.

Notes:

METRIC CONVERSIONS

Units of Length

Unit	Centimeter	Inch	Foot	Yard	Mile	Meter	Kilometer	Millimeter
1 centimeter	—	0.3937	0.03281	0.01094	6.214×10^{-6}	0.01	—	—
1 inch	2.540	—	0.08333	0.2778	1.578×10^{-5}	0.254	—	25.4
1 foot	30.480	12.0	—	0.3333	1.893×10^{-4}	0.3048	—	—
1 yard	91.44	36.0	3.0	—	5.679×10^{-4}	0.9144	—	—
1 meter	100.0	39.37	3.281	1.094	6.214×10^{-4}	—	—	—
1 mile	1.609×10^5	6.336×10^4	5.280×10^3	1.760×10^3	—	1.609×10^3	1.609	—
1 mm	—	0.03937	—	—	—	—	—	—
1 kilometer	—	—	—	—	0.621	—	—	—

Temperature Conversions

Temperature	° Fahrenheit	° Centigrade
Water freezes	32	0
Water boils	212	100
Absolute 0	-459.69	-273.16

Formulas
$^{\circ}\text{C} = (\text{F} - 32) * 0.555$
$^{\circ}\text{F} = (\text{C} * 1.8) + 32$

Units of Weight

Unit	Gram	Ounce Avoirdupois	Ounce Troy	Pound Avoirdupois	Pound Troy	Kilogram
1 gram	—	0.03527	0.03215	0.002205	0.002679	0.001
1 oz. avoird.	28.35	—	0.9115	0.0625	0.07595	0.02835
1 oz. troy	31.10	1.097	—	0.06857	0.08333	0.03110
1 lb. avoird.	453.6	16.0	14.58	—	1.215	0.4536
1 lb. Troy	373.2	13.17	12.0	0.8229	—	0.3732
1 kilogram	1.0×10^3	35.27	32.15	2.205	2.679	—



2114 WEST 7TH STREET TEMPE ARIZONA 85281 USA
480 • 333 • 2200 PHONE
480 • 333 • 2161 FAX