

# STS11/STS11L

## Solid-State Transfer Switch

### Installation and Operation Manual

TM109  
Revision 1.1





---

## Warranty Policy



Radyne ComStream, Inc. (Seller) warrants the items manufactured and sold by Radyne ComStream, Inc. to be free of defects in material and workmanship for a period of two (2) years from date of shipment unless other terms are specified. Radyne ComStream, Inc.'s obligation under its warranty is limited in accordance with the periods of time and all other conditions stated in all provisions of this warranty.

This warranty applies only to defects in material and workmanship in products manufactured by Radyne ComStream, Inc. Radyne ComStream, Inc. makes no warranty whatsoever concerning products or accessories not of its manufacture. Repair, or at the option of Radyne ComStream, Inc., replacement of the Radyne ComStream, Inc. products or defective parts therein shall be the sole and exclusive remedy for all valid warranty claims.

### Warranty Period

The applicable warranty period shall commence on the date of shipment from a Radyne ComStream, Inc. facility to the original purchaser and extend for the stated period following the date of shipment. Upon beginning of the applicable Radyne ComStream, Inc. warranty period, all customers' remedies shall be governed by the terms stated or referenced in this warranty. In-warranty repaired or replacement products or parts are warranted only for the remaining unexpired portion of the original warranty period applicable to the repaired or replaced products or parts. Repair or replacement of products or parts under warranty does not extend the original warranty period.

### Warranty Coverage Limitations

The following are expressly **not covered** under warranty:

1. Any loss, damage and/or malfunction relating in any way to shipping, storage, accident, abuse, alteration, misuse, neglect, failure to use products under normal operating conditions, failure to use products according to any operating instructions provided by Radyne ComStream, Inc., lack of routine care and maintenance as indicated in any operating maintenance instructions, or failure to use or take any proper precautions under the circumstances.
2. Products, items, parts, accessories, subassemblies, or components which are expendable in normal use or are of limited life, such as but not limited to, bulbs, fuses, lamps, glassware, etc. Radyne ComStream, Inc. reserves the right to revise the foregoing list of what is covered under this warranty.

### Warranty Replacement and Adjustment

Radyne ComStream, Inc. will not make warranty adjustments for failures of products or parts, which occur after the specified maximum adjustment period. Unless otherwise agreed, failure shall be deemed to have occurred no more than seven (7) working days before the first date on which Radyne ComStream, Inc. receives a notice of failure. Under no circumstances shall any warranty exceed the period stated above unless expressly agreed to in writing by Radyne ComStream, Inc.

### Liability Limitations

This warranty is expressly in lieu of and excludes all other express and implied warranties, including but not limited to warranties of merchantability and of fitness for particular purpose, use, or applications, and all other obligations or liabilities on the part of Radyne ComStream, Inc., unless such other warranties, obligations, or liabilities are expressly agreed to in writing by Radyne ComStream, Inc.

All obligations of Radyne ComStream, Inc. under this warranty shall cease in the event its products or parts thereof have been subjected to accident, abuse, alteration, misuse or neglect, or which have not been operated and maintained in accordance with proper operating instructions.

In no event shall Radyne ComStream, Inc. be liable for Incidental, consequential, special or resulting loss or damage of any kind howsoever caused. Radyne ComStream, Inc.'s liability for damages shall not exceed the payment, if any, received by Radyne ComStream, Inc. for the unit or product or service furnished or to be furnished, as the case may be, which is the subject of claim or dispute.

Statements made by any person, including representatives of Radyne ComStream, Inc., which are inconsistent or in conflict with the terms of this warranty, shall not be binding upon Radyne ComStream, Inc. unless reduced to writing and approved by an officer of Radyne ComStream, Inc.

### **Warranty Repair Return Procedure**

Before a warranty repair can be accomplished, a Repair Authorization must be received. It is at this time that Radyne ComStream, Inc. will authorize the product or part to be returned to the Radyne ComStream, Inc. facility or if field repair will be accomplished. The Repair Authorization may be requested in writing or by calling:

#### **Radyne ComStream, Inc.**

3138 E. Elwood St.  
Phoenix, Arizona 85034 (USA)  
ATTN: Customer Support  
Phone: (602) 437-9620  
Fax: (602) 437-4811

Any product returned to Radyne ComStream, Inc. for examination must be sent prepaid via the means of transportation indicated as acceptable to Radyne ComStream, Inc. Return Authorization Number must be clearly marked on the shipping label. Returned products or parts should be carefully packaged in the original container, if possible, and unless otherwise indicated, shipped to the above address.

### **Non-Warranty Repair**

When a product is returned for any reason, Customer and its shipping agency shall be responsible for all damage resulting from improper packing and handling, and for loss in transit, not withstanding any defect or nonconformity in the product. By returning a product, the owner grants Radyne ComStream, Inc. permission to open and disassemble the product as required for evaluation. In all cases, Radyne ComStream, Inc. has sole responsibility for determining the cause and nature of failure, and Radyne ComStream, Inc.'s determination with regard thereto shall be final.

---

## Preface

# P

This manual provides installation and operation information for the Radyne ComStream STS11 and the STS11L Solid-State Transfer Switches. This is a technical document intended for use by engineers, technicians, and operators responsible for the operation and maintenance of the Solid-State Transfer Switches.

### Conventions

Whenever the information within this manual instructs the operator to press a pushbutton switch or keypad key on the Front Panel, the pushbutton or key label will be shown enclosed in "less than" (<) and "greater than" (>) brackets. For example, the Reset Alarms Pushbutton will be shown as <RESET ALARMS>, while a command that calls for the entry of a '7' followed by 'ENTER' Key will be represented as <7,ENTER>.

### Cautions and Warnings



A caution icon indicates a hazardous situation that if not avoided, may result in minor or moderate injury. Caution may also be used to indicate other unsafe practices or risks of property damage.



A warning icon indicates a potentially hazardous situation that if not avoided, could result in death or serious injury.



A note icon identifies information for the proper operation of your equipment, including helpful hints, shortcuts, or important reminders.

## Trademarks

Product names mentioned in this manual may be trademarks or registered trademarks of their respective companies and are hereby acknowledged.

## Copyright

©2005, Radyne ComStream, Inc. This manual is proprietary to Radyne ComStream, Inc. and is intended for the exclusive use of Radyne ComStream, Inc.'s customers. No part of this document may in whole or in part, be copied, reproduced, distributed, translated or reduced to any electronic or magnetic storage medium without the express written consent of a duly authorized officer of Radyne ComStream, Inc.

## Disclaimer

This manual has been thoroughly reviewed for accuracy. All statements, technical information, and recommendations contained herein and in any guides or related documents are believed reliable, but the accuracy and completeness thereof are not guaranteed or warranted, and they are not intended to be, nor should they be understood to be, representations or warranties concerning the products described. Radyne ComStream, Inc. assumes no responsibility for use of any circuitry other than the circuitry employed in Radyne ComStream, Inc. systems and equipment. Furthermore, since Radyne ComStream, Inc. is constantly improving its products, reserves the right to make changes in the specifications of products, or in this manual at any time without notice and without obligation to notify any person of such changes.

## Record of Revisions

Revision Level	Date	Reason for Change
1.0	8-25-04	Initial Release
1.1	2-10-05	Revised product name from RCS11-STS to STS11. Added STS11L L-Band Transfer Switch information.

## Comments or Suggestions Concerning this Manual

Comments or suggestions regarding the content and design of this manual are appreciated. To submit comments, please contact the Radyne ComStream, Inc. Customer Service Department.

---

**Table of Contents**The logo consists of the letters 'ToC' in a white, serif font, centered within a solid black square.**Section 1 - Introduction**

1.0 Overview _____	1-1
--------------------	-----

**Section 2 - Installation**

2.0 Installation Requirements _____	2-1
2.1 Unpacking _____	2-1
2.1.1 Test Data Sheet _____	2-2
2.2 System Connections _____	2-2
2.3 Connecting to DM240 Digital Modulators _____	2-2

**Section 3 - Operation**

3.0 Solid-State Transfer Switch Operation _____	3-1
3.1 Operating Procedures _____	3-2
3.2 Solid-State Transfer Switch Backup Operation _____	3-2

**Section 4 - Maintenance and Troubleshooting**

4.0 Basic Troubleshooting and Maintenance _____	4-1
4.1 Basic User Checks _____	4-1
4.1.1 Checking the Cabling and Connectors _____	4-1

**Section 5 - Technical Specifications**

5.0 Introduction _____	5-1
5.1 General Specifications _____	5-1
5.2 Power and Environmental _____	5-1
5.3 Physical _____	5-1



# Introduction



## 1.0 Overview

The Radyne ComStream, Inc. STS11 (70/140 MHz) and STS11L (L-Band) Solid-State Transfer Switches (Figures 1-1 and 1-2) provide simple backup redundancy protection for the DM240 Modulators. Their straightforward design and easy access to connectors and LEDs allow for ease of use.

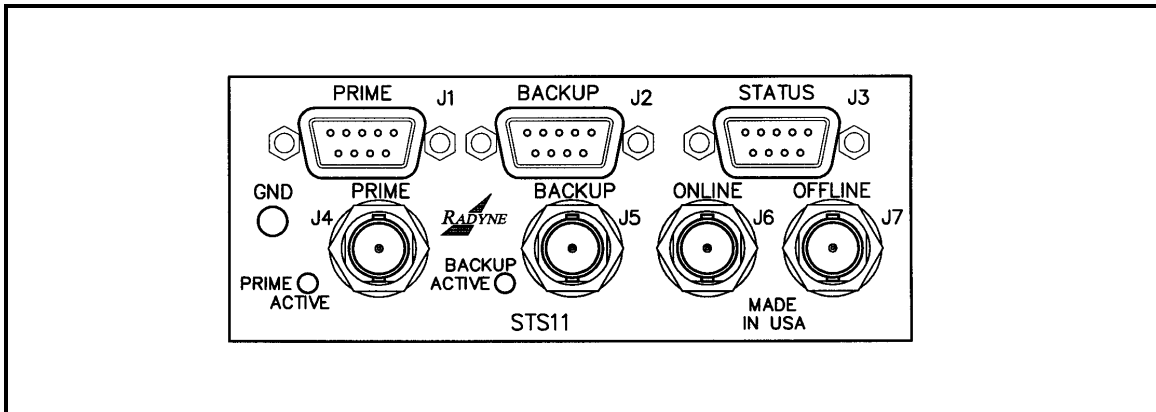

Figure 1-1. STS11 Solid-State Transfer Switch

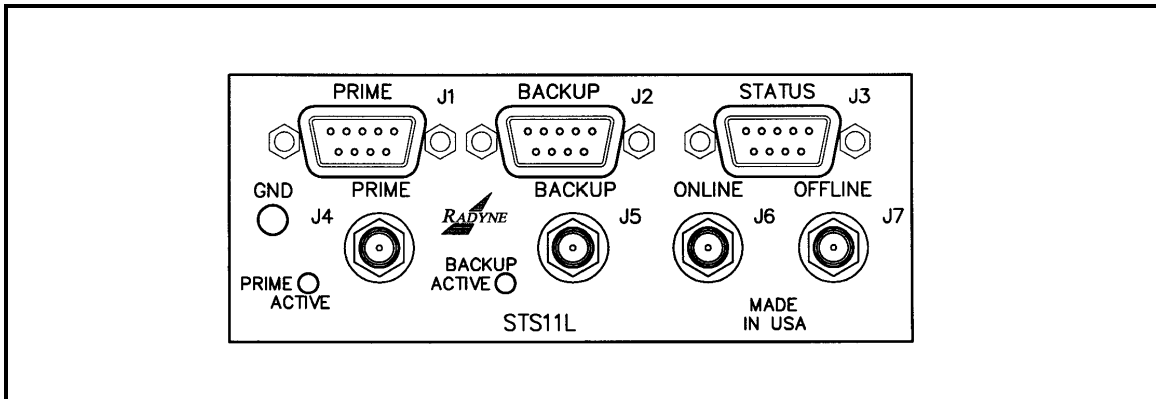

Figure 1-2. STS11L L-Band Solid-State Transfer Switch



## Installation

# 2

This section provides unpacking and installation instructions, and a description of external connections and backward alarm information.

### 2.0 Installation Requirements

The STS11 and STS11L Solid-State Transfer Switches are designed for installation in any convenient location (with the included brackets). They stand one rack unit (1RU) high (1.75 inches/4.45 cm) vertically, 4.4 inches (11.18 cm) wide, and 3.4 inches (8.63 cm) deep.



### **WARNING!!**

*There are no user-serviceable parts or configuration settings located inside any Solid-State Transfer Switch Chassis. There is a potential shock hazard internally at the power supply module. DO NOT open the Solid-State Transfer Switch Chassis under any circumstances.*



### **CAUTION!!**

*Before initially applying power to the unit, it is a good idea to disconnect the transmit output from the operating ground station equipment. This is especially true if the current Solid-State Transfer Switch configuration settings are unknown, where incorrect settings could disrupt existing communications traffic.*

### 2.1 Unpacking

The STS11/STS11L Solid-State Transfer Switch was carefully packaged to avoid damage and should arrive complete with the following items for proper installation:

- STS11 or STS11L Solid-State Transfer Switch Unit
- STS11 or STS11L Test Data Sheet
- Interconnect Cables and Materials as Required
- Mounting Brackets
- Installation and Operation Manual

### 2.1.1 Test Data Sheet

Each STS11/STS11L Solid-State Transfer Switch is shipped with a Test Data Sheet. This report contains information on the results of the Switch quality control testing. The report also includes information pertaining to the system settings that were made at the factory. Radyne ComStream, Inc. recommends that the user save this report for future reference.

### 2.2 System Connections

For initial Solid-State Transfer Switch setup and configuration, perform the following procedure:

1. Interconnect the units as shown in the figures below.
2. Proceed to Section 4, User Interface for information on the Solid-State Transfer Switch controls and indicators.

### 2.3 Connecting to DM240 Digital Modulators

Figure 2-1 illustrates the cable connections between the STS11 and two DM240 units. Refer to Table 2-1 for cable part numbers.

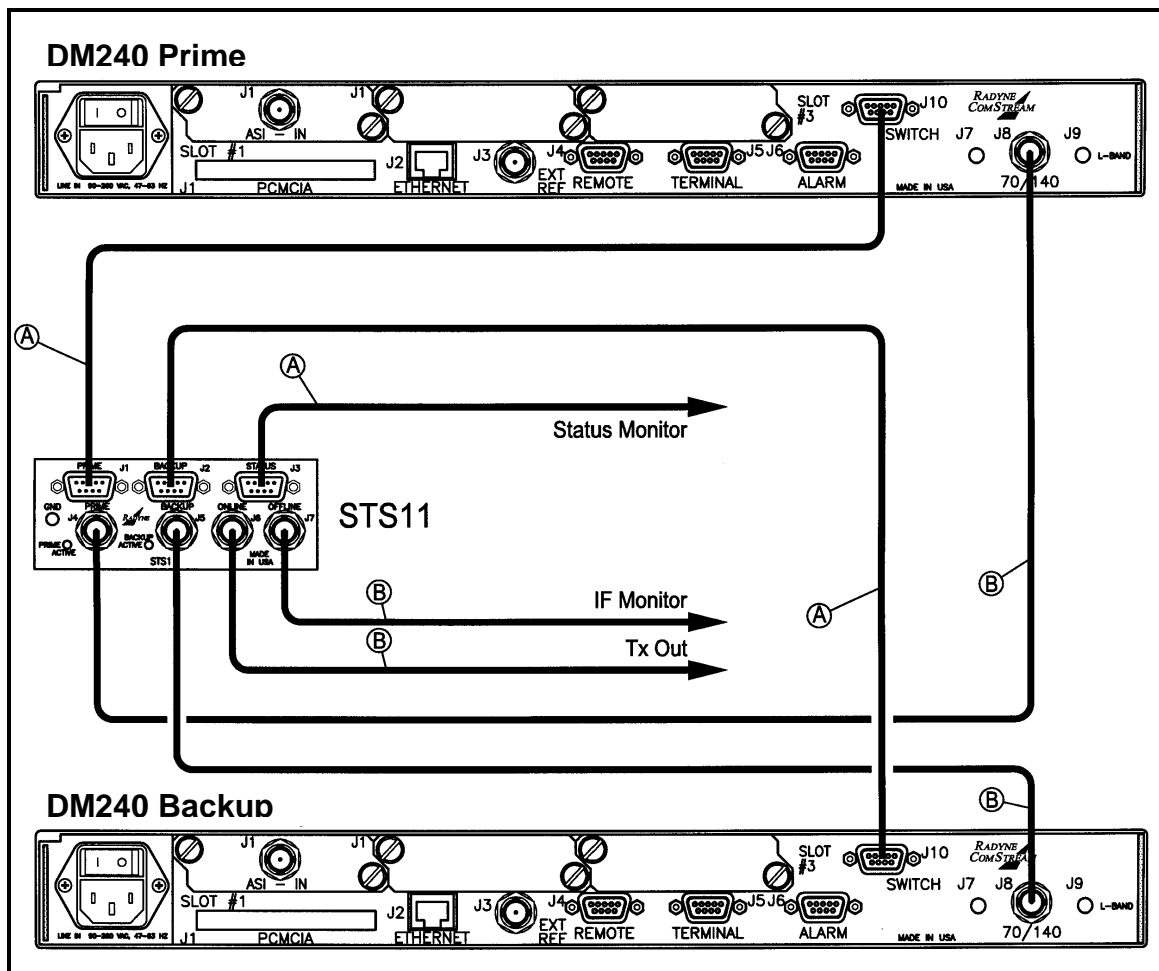

Figure 2-1. STS11 Solid-State Transfer Switch to DM240 Connections

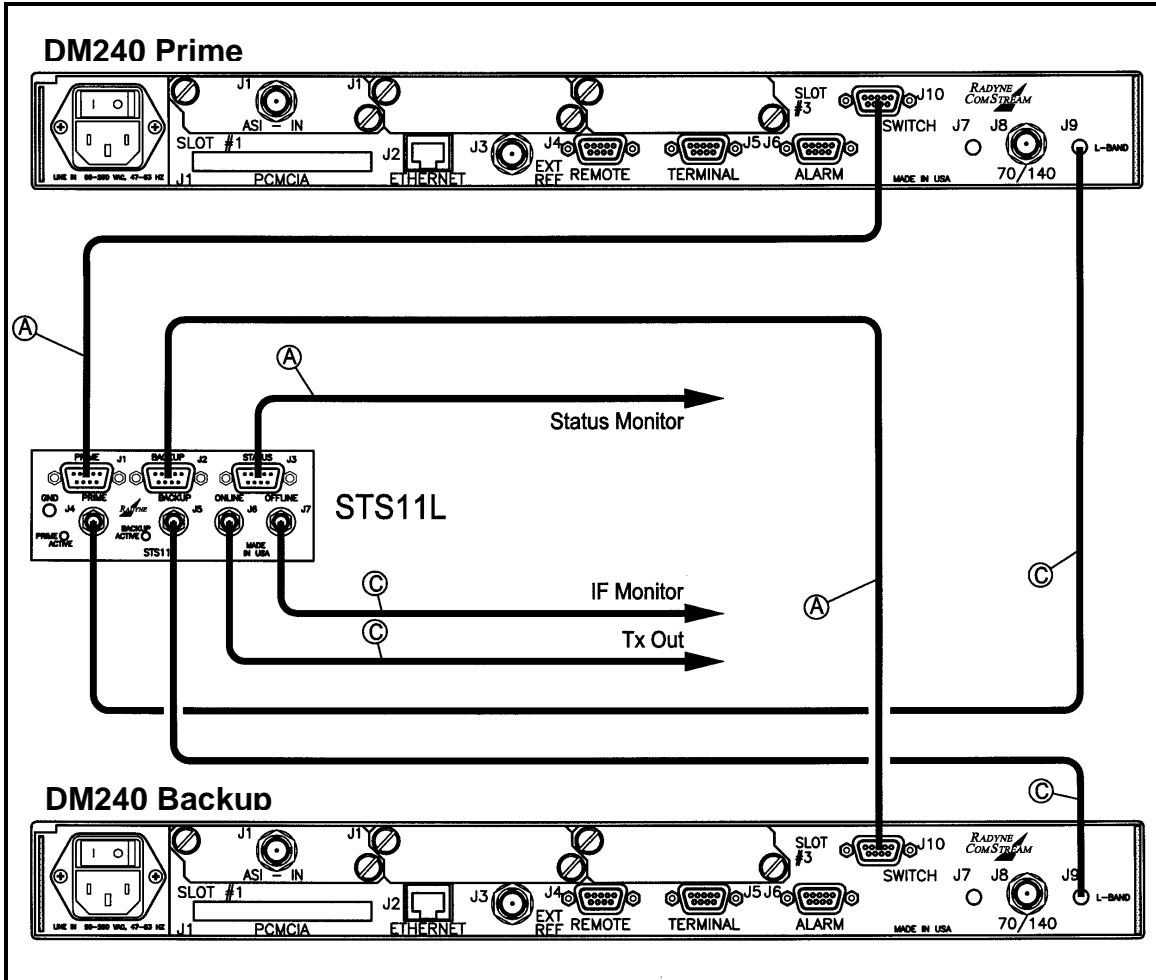

Figure 2-2. STS11L Solid-State Transfer Switch to DM240 Connections

Table 2-1. Interconnection Cable Part Numbers			
Cable	Quantity	Name	Part Number
A	3	Control Cable (DB-9 Straight Cable)	TBD
B	4	IF Cable (75-Ohm BNC)	TBD
C	4	L-Band Cable (50-Ohm SMA)	TBD



**Operation**

**3**

**3.0 Solid-State Transfer Switch Operation**

A block diagram of the signal flow is shown in Figure 3-1 (70/140 MHz) and Figure 3-2 (L-Band) below.

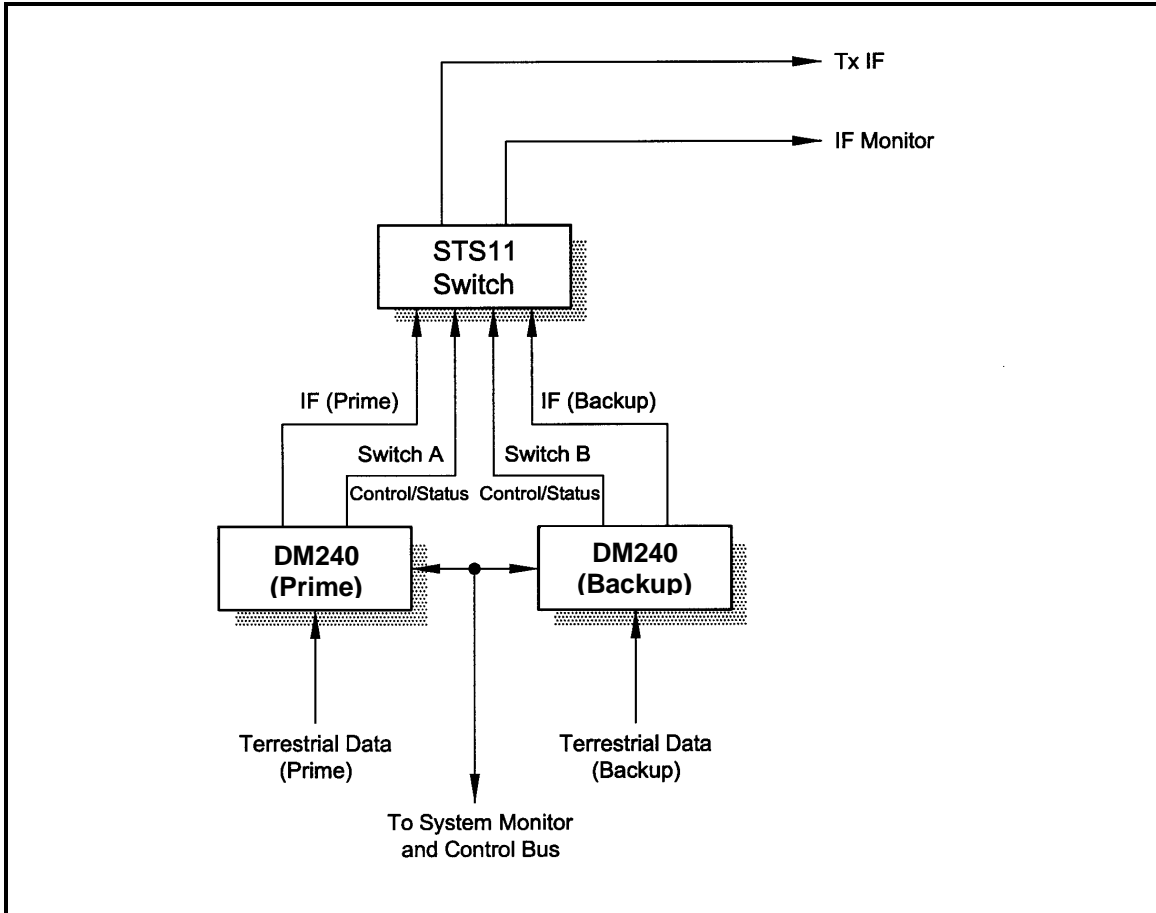

**Figure 3-1. STS11 Functional Block Diagram**

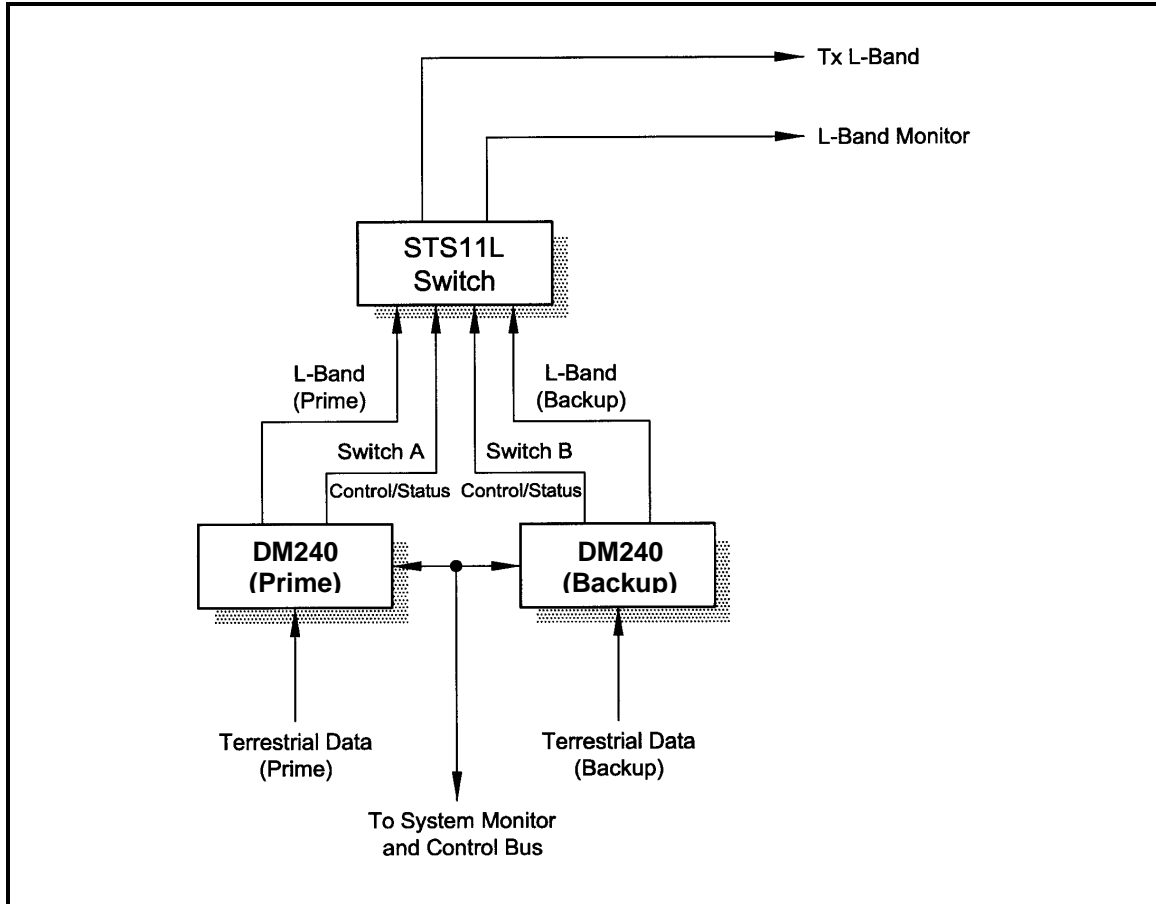

Figure 3-2. STS11L Functional Block Diagram

### 3.1 Operating Procedures

The Solid-State Transfer Switch is designed to require minimal operator intervention and control during normal operation. After initial setup, the unit should operate in a relatively 'transparent' manner, providing trouble-free backup of the online modulators.

### 3.2 Solid-State Transfer Switch Backup Operation

Each modulator monitors the fault status of the other modulators through the switch. An additional connector has been added to the standard DM240 to provide a wiring port to the external IF switch. Each modulator is capable of powering the IF switch through a current limited, diode or'ed power signal. Either of the DM240s is also capable of commanding the switch to the prime or backup state, as well as monitoring in which state it is. In normal operation, the M&C in the backup modulator monitors the prime for faults. If one is detected, it will automatically cause the IF switch to place the backup on-line. The switch is non-revertive. That is, once a switch occurs, it requires a manual command (either through the M&C or from the front panel) to return the prime unit on-line. This will be the default operation, but the switching software is capable of implementing revertive switching as well. Either modulator will be capable of changing the state of the IF switch (assuming it is not faulted). This can be done remotely or from the front panel. Remote control will occur through the standard Ethernet M&C interface implementing SNMP. The switch connectors are listed in Tables 3-1 and 3-2.

<b>Table 3-1. STS11 Connectors</b>		
<b>Connector ID</b>	<b>Nomenclature</b>	<b>Description</b>
J1	Prime Mod Control	9-Pin D-Sub Control Connector From Prime Modulator
J2	Backup Mod Control	9-Pin D-Sub Control Connector From Backup Modulator
J3	Switch Status Output	9-Pin D-Sub Switch Status Form-C Relay Outputs
J4	Prime Mod Input	75 Ohm, BNC From Prime Modulator
J5	Backup Mod Input	75 Ohm, BNC From Backup Modulator
J6	On-Line Output	75 Ohm Output of On-Line Modulator to Uplink Chain.
J7	Off-Line Output	75 Ohm Output of Monitor Port of Off-Line Modulator

<b>Table 3-2. STS11L Connectors</b>		
<b>Connector ID</b>	<b>Nomenclature</b>	<b>Description</b>
J1	Prime Mod Control	9-Pin D-Sub Control Connector From Prime Modulator
J2	Backup Mod Control	9-Pin D-Sub Control Connector From Backup Modulator
J3	Switch Status Output	9-Pin D-Sub Switch Status Form-C Relay Outputs
J4	Prime Mod Input	50 Ohm, SMA From Prime Modulator
J5	Backup Mod Input	50 Ohm, SMA From Backup Modulator
J6	On-Line Output	50 Ohm, SMA Output of On-Line Modulator to Uplink Chain.
J7	Off-Line Output	50 Ohm, SMA Output of Monitor Port of Off-Line Modulator

Each modulator has a 9-Pin D-Sub Connector for the switch. A 1:1 cable is connected from each modulator to the switch. The pinout for the control connector is listed in Table 3-3.

<b>Table 3-3. Switch Control Pinout</b>			
<b>Pin No.</b>	<b>Signal Name</b>	<b>Direction</b>	<b>Description</b>
5	Signal Ground	Input	Modulator GND
9	Backup Select	Output	One modulator is designated as Backup. This line is tied low on the Backup Mod Control connector.
1	+DC	Input	+12V DC Power
2	nPrime_Sel	Input	Forces On-Line Output to Prime
7	nBackup_Sel	Input	Forces On-Line Output to Backup
8	Fault-In	Input	Fault Output From Modulator
4	Fault-Out	Output	Connects to Fault-In Monitor on Modulator
3	Switch-State	Output	Switch State Monitor. Logic '1' = Prime Online
6	NC	---	---

An additional 9-Pin D-Sub Connector is supplied for switch monitoring. The I/O on this connector comes from a Form-C relay. The pinouts for the monitor connector is listed in Table 3-4.

<b>Table 3-4. Switch Monitor Pinout</b>		
<b>Pin No.</b>	<b>Signal Name</b>	<b>Description</b>
4	Signal Ground	Switch GND
1	Relay 1 NO	Relay Normally Open Contact (Closed When the Backup Modulator is On-Line)
3	Relay 1 NC	Relay Normally Closed Contact (Closed When the Prime Modulator is Online)
2	Relay 1 C	Relay Common Contact
7	Relay 2 NO	Relay Normally Open Contact
9	Relay 2 NC	Relay Normally Closed Contact
8	Relay 2 C	Relay Common Contact
5	NC	---
6	NC	---

---

## Maintenance and Troubleshooting

# 4

### 4.0 Basic Troubleshooting and Maintenance

This section provides information on the basic troubleshooting and repair procedures for the Solid-State Transfer Switch that may be performed on-site by qualified personnel. Only minor repairs will be discussed. For serious failures, the user should not attempt to repair the unit without first contacting the Radyne ComStream Corporation Customer Service Department at 602-437-9620 for further information and instructions.

#### 4.1 Basic User Checks

Upon the detection of an operational failure, the source of the failure must be determined. Basic user checks include checking the power line fuses, and the various cables and connectors.

##### 4.1.1 Checking the Cabling and Connectors

Problems that appear difficult to solve can often be traced to a loose or defective cable or connector. The user should first verify the following:

- All cables within the system have no broken or loose connections. Cables that are suspect should be replaced.
- All jacks on the units have no bent or broken pins.



---

## Technical Specifications

# 5

### 5.0 Introduction

This section defines the technical performance parameters and specifications for the Solid-State Transfer Switch.

### 5.1 General Specifications

Configuration:	Modulator Only
Switch Time:	50 msec Maximum
Ports:	IF: BNC, 75 Ohms L-Band: SMA, 50 Ohms
Control Ports:	DB-9 Male
Status Port:	DB-9 Male
Return Loss:	20 dB

### 5.2 Power and Environmental

Prime Power:	+12 VDC Provided to the Unit Through the Prime and Backup Cabling from the Modulator
Operating Temp:	0 to 50°C, 95% Humidity, Non-Condensing
Storage Temp:	-20 to 70°C, 99% Humidity, Non-Condensing

### 5.3 Physical

Size:	4.4" W x 3.4" D x 1.75" H (11.18 cm x 8.63 cm x 4.45 cm)
Weight:	0.5 lb. (0.22 Kg)

