



# *LGAN*

---

## Outdoor Amplifier / Block Up Converter (BUC) Installation and Operation Manual

Part Number MN-LGAN  
Revision 0

**IMPORTANT NOTE:** The information contained in this document supersedes all previously published information regarding this product. Product specifications are subject to change without prior notice.

Copyright © 2020 Comtech EF Data. All rights reserved. Printed in the USA.  
Comtech EF Data, 2114 West 7th Street, Tempe, Arizona 85281 USA, 480.333.2200, FAX: 480.333.2161

## Revision History

Rev	Date	Description
0	Feb 2020	Initial Release.

# Table of Contents

<b>PREFACE</b> .....	<b>I</b>
<b>About this Manual</b> .....	<b>i</b>
Related Documents .....	i
Disclaimer .....	i
<b>Conventions and References</b> .....	<b>i</b>
Patents and Trademarks .....	i
Warnings, Cautions, Notes, and References .....	ii
Examples of Multi-Hazard Notices .....	ii
Recommended Standard Designations .....	ii
<b>Safety and Compliance</b> .....	<b>iii</b>
Electrical Safety and Compliance .....	iii
Installation Guidelines Regarding Power Line Quality .....	iii
<b>Product Support</b> .....	<b>iv</b>
<b>Comtech EF Data Headquarters</b> .....	<b>iv</b>
<b>Warranty Policy</b> .....	<b>v</b>
Limitations of Warranty .....	vi
Exclusive Remedies .....	vi
<b>CHAPTER 1. INTRODUCTION</b> .....	<b>1-1</b>
<b>1.1 Overview</b> .....	<b>1-1</b>
<b>1.2 Functional Description</b> .....	<b>1-2</b>
<b>1.3 Features</b> .....	<b>1-2</b>
1.3.1 The Solid-State Advantage .....	1-2
1.3.2 Monitor and Control (M&C) .....	1-2
1.3.3 Enhanced Standard Features .....	1-2
1.3.4 “Smart BUC” Functionality .....	1-2
1.3.5 Data Logging Capability .....	1-3
1.3.6 Optional Internal 10 MHz Reference .....	1-3
1.3.7 Optional LNB Support .....	1-3
1.3.8 SSPA Module .....	1-3
1.3.9 Cooling System .....	1-3
1.3.10 Temperature and RF Overdrive .....	1-4
1.3.10.1 Overview .....	1-4
1.3.10.2 Over Temperature .....	1-4
1.3.10.3 Over Drive (Excessive RF Input Level) .....	1-5
1.3.11 Maximum Operating Points .....	1-5
1.3.12 Power Supply .....	1-5
1.3.13 LNB Operation .....	1-5
1.3.14 Block Up Converter (BUC) Input .....	1-6
<b>1.4 Dimensional Envelopes</b> .....	<b>1-7</b>
1.4.1 LGaN 50 W Dimensional Envelopes .....	1-7
1.4.2 LGaN 100 W Dimensional Envelopes .....	1-9
<b>CHAPTER 2. SYSTEM CONNECTORS, INSTALLATION, AND STARTUP</b> .....	<b>2-1</b>
<b>2.1 Overview</b> .....	<b>2-1</b>
<b>2.2 Water Tight Sealing</b> .....	<b>2-2</b>
2.2.1 Customer Cable Assemblies .....	2-2
<b>2.3 Connectors and Cables</b> .....	<b>2-3</b>
2.3.1 Connector ‘J1   LBAND IN’ or ‘J1   Tx IN’ .....	2-5
2.3.2 Connector ‘J2   RF OUT’ .....	2-5

2.3.3	Connector 'J3   POWER IN'	2-6
2.3.3.1	Connector 'J3   POWER IN' AC Power Main – 100 W	2-6
2.3.3.2	Connector 'J3   POWER IN' DC Power Mains	2-6
2.3.3.2.1	Connector 'J3   POWER IN' DC Power Main – 50 W	2-6
2.3.3.2.2	Connector 'J3   POWER IN' DC Power Main – 100 W	2-7
2.3.4	Connector 'J6   COM1' (Remote Communications and Discrete Control Port)	2-8
2.3.5	Connector 'J10   MOD Rx' – 100 W	2-9
2.3.6	Connector 'J11   LNB' – 100 W	2-9
2.3.7	Ground Connector	2-9
2.3.8	BUC DC Power Supply Cable	2-10
2.3.8.1	DC Power Supply Cable – 50 W	2-10
2.3.8.2	DC Power Supply Cable – 100 W	2-10
2.3.9	Monitor and Control Cable	2-11
<b>2.4</b>	<b>LGaN Power</b>	<b>2-11</b>
<b>CHAPTER 3.</b>	<b>FIRMWARE UPDATE</b>	<b>3-1</b>
<b>3.1</b>	<b>Firmware Update Overview</b>	<b>3-1</b>
3.1.1	Important Considerations	3-1
3.1.2	LGaN Firmware Update Procedure Summary	3-1
3.1.3	About Firmware Numbers, File Versions, and Formats	3-2
<b>3.2</b>	<b>Prepare for the Firmware Download</b>	<b>3-2</b>
3.2.1	Required User-supplied Items	3-2
3.2.1.1	LGaN Connections	3-3
3.2.2	LGaN Management IP Address and Firmware Information	3-3
3.2.2.1	Locate Firmware Information via HTTP Interface	3-3
<b>3.3</b>	<b>Download and Extract the Firmware Update Files</b>	<b>3-4</b>
<b>CHAPTER 4.</b>	<b>ETHERNET INTERFACE OPERATION</b>	<b>4-1</b>
<b>4.1</b>	<b>Overview</b>	<b>4-1</b>
4.1.1	Prerequisites	4-1
<b>4.2</b>	<b>SNMP Interface</b>	<b>4-2</b>
4.2.1	Management Information Base (MIB) Files	4-2
4.2.1.1	CEFD Root MIB File	4-2
4.2.1.2	LGaN MIB File	4-2
4.2.1.3	LGaN Traps MIB File	4-2
4.2.2	SNMP Community Strings	4-3
4.2.3	SNMP Traps	4-3
<b>4.3</b>	<b>Telnet Interface</b>	<b>4-6</b>
4.3.1	Telnet Remote Control Operation via HyperTerminal	4-6
4.3.1.1	Configure Tera Term for Telnet Remote Control Operation	4-7
<b>4.4</b>	<b>HTTP (Web Server) Interface</b>	<b>4-8</b>
4.4.1	Enable the HTTP Interface	4-8
4.4.2	HTTP Interface User Login	4-9
4.4.3	HTTP Interface Features	4-10
4.4.3.1	Menu Tree	4-10
4.4.4	HTTPS Web Navigation	4-11
4.4.4.1	Page Navigation	4-11
4.4.4.2	Page Sections	4-11
4.4.4.3	Action Buttons	4-11
4.4.4.4	Drop-down Lists	4-11
4.4.4.5	Text or Data Entry	4-11
<b>4.5</b>	<b>HTTP Interface Pages</b>	<b>4-12</b>
4.5.1	Home Pages	4-12
4.5.1.1	Home   Home	4-12

4.5.1.2	Home   Contact .....	4-13
4.5.2	Admin (Administration) Pages .....	4-14
4.5.2.1	Admin   Access .....	4-14
4.5.2.2	Admin   Time .....	4-15
4.5.2.3	Admin   SNMP .....	4-16
4.5.2.4	Admin   Upgrade .....	4-17
4.5.3	Config Pages .....	4-18
4.5.3.1	Config   Amplifier .....	4-18
4.5.3.2	Config   LNB .....	4-20
4.5.3.3	Configuration   Mask .....	4-21
4.5.3.4	Config   Utility .....	4-22
4.5.4	Status Pages .....	4-23
4.5.4.1	Status   Summary .....	4-23
4.5.4.2	Status   Status .....	4-24
4.5.4.4	Status   Events .....	4-26
4.5.4.5	Status   MOP .....	4-27
4.5.4.6	Status   Statistics .....	4-28
4.5.4.7	Status   Trending .....	4-29
<b>CHAPTER 5. SERIAL INTERFACE OPERATION .....</b>		<b>5-1</b>
<b>5.1</b>	<b>Overview .....</b>	<b>5-1</b>
<b>5.2</b>	<b>Key Operational Parameters / Common Commands and Queries.....</b>	<b>5-2</b>
5.2.1	Faults .....	5-2
5.2.2	Common Commands.....	5-2
<b>5.3</b>	<b>Remote Control Protocol and Structure .....</b>	<b>5-3</b>
5.3.1	EIA-232 .....	5-3
5.3.2	EIA-485 .....	5-3
5.3.3	EIA-485 (Full Duplex) .....	5-4
5.3.4	EIA-232 .....	5-4
5.3.5	Basic Protocol .....	5-4
<b>5.4</b>	<b>Packet Structure.....</b>	<b>5-5</b>
5.4.1	Start of Packet.....	5-6
5.4.2	Address.....	5-6
5.4.3	Address Delimiter.....	5-6
5.4.4	Instruction Code.....	5-6
5.4.5	Instruction Code Qualifier .....	5-7
5.4.6	Message Arguments .....	5-8
5.4.7	End of Packet.....	5-8
5.4.8	End of Life Commands .....	5-8
<b>5.5</b>	<b>Remote Commands and Queries.....</b>	<b>5-9</b>
5.5.1	Customer Commands.....	5-11
<b>APPENDIX A. CABLE DRAWINGS .....</b>		<b>A-1</b>
<b>A.1</b>	<b>Overview .....</b>	<b>A-1</b>
<b>A.2</b>	<b>Control and Data Cables.....</b>	<b>A-2</b>
A.2.1	Serial Interface Cable .....	A-3
A.2.2	Ethernet Interface Cable.....	A-4
A.2.3	19-Pin COMMS Cable (100') .....	A-5
A.2.4	19-Pin COMMS Cable (250') .....	A-6
<b>A.3</b>	<b>RF Cables.....</b>	<b>A-7</b>
A.3.1	RF Cable (Type 'N') .....	A-8

## List of Tables

Table 2-1. Connector 'J3   POWER IN' Pin Assignments – 100 W .....	2-6
Table 2-2. LGaN 50 W 'J3   POWER IN' Pin Assignments .....	2-7
Table 2-3. LGaN 100 W 'J3   POWER IN' Pin Assignments .....	2-7
Table 2-4. LGaN 'J6   COM1' Pin Assignments.....	2-8

## List of Figures

Figure 1-1. LGaN Outdoor Amplifier/ BUC (50 W) .....	1-1
Figure 1-2. LGaN Outdoor Amplifier/ BUC (100 W) .....	1-1
Figure 1-3. LGaN 50 W Dimensional Envelope (1 of 2) .....	1-7
Figure 1-4. LGaN 50 W Dimensional Envelope (2 of 2) .....	1-8
Figure 1-5. LGaN 100 W Ku-Band Dimensional Envelope (1 of 2) .....	1-9
Figure 1-6. LGaN 100 W Ku-Band Dimensional Envelope (2 of 2) .....	1-10
Figure 2-1. LGaN 50 W Connectors .....	2-3
Figure 2-2. LGaN 100 W Connectors .....	2-3
<b>Figure 2-3. Circular Connector Example</b> .....	2-4
Figure 2-4. LGaN Ground Connector Locations .....	2-9
Figure 3-1. Upgrade Webpage Example.....	3-2
<b>Figure 3-2. Standalone Ethernet Connection</b> .....	3-3
Figure 4-1. Telnet Interface Example – Windows Command-line .....	4-6
Figure 4-2. Telnet Interface Example – Tera Term .....	4-7
Figure 4-3. Configure Tera Term .....	4-7
Figure 4-4. Open Windows Command-line.....	4-8
Figure 4-5. Telnet Login and Remote Command Execution .....	4-9
Figure 4-6. LGaN HTTP Interface 'Splash' Page Example .....	4-10
Figure 4-7. LGaN HTTP Interface Menu Tree.....	4-10
Figure 4-8. LGaN 'Home   Home' Page (50 W Unit Example Shown).....	4-12
Figure 4-9. 'Home   Contact' Page .....	4-13
Figure 4-10. 'Admin   Access' Page .....	4-14
Figure 4-11. 'Admin   Access' Page.....	4-15
Figure 4-12. 'Admin   SNMP' Page .....	4-16
Figure 4-13. 'Admin   Upgrade' Page.....	4-17
Figure 4-14. 'Config   Amplifier' Page .....	4-18
Figure 4-15. 'Config   LNB' Page .....	4-20
Figure 4-16. 'Configuration   Mask' Page.....	4-21
Figure 4-17. 'Configuration   Utility' Page.....	4-22
Figure 4-18. 'Status   Summary' Page .....	4-23
Figure 4-19. 'Status   Status' Page .....	4-24
Figure 4-20. 'Status   FETs' Page.....	4-25
Figure 4-21. 'Status   Events' Page.....	4-26
Figure 4-22. 'Status   MOP' Page.....	4-27
Figure 4-23. 'Status   Statistics' Page.....	4-28
Figure 4-24. 'Status   Trending Graphs' Page .....	4-29
Figure A-1. Serial Interface Cable (CEFD P/N CA-0020526, part of KT-0020518) .....	A-3
Figure A-2. Ethernet Interface Cable (CEFD P/N CA-0000352, part of KT-0000203) .....	A-4
Figure A-3. COMMS Cable, 100' (CEFD P/N CA-0000318) .....	A-5
Figure A-4. COMMS Cable, 250' (CEFD P/N CA-0000543) .....	A-6
Figure A-5. 1/4" Helix Coaxial Cable (CEFD P/N CA/3722-X).....	A-8

## Acronym List

Acronym	Description	First Use Page Numbe
AO	Assignment Operator	5-6
BUC	Block Up Converter	1-1
CEFD	Comtech EF Data	1-1
DC	Direct Current	1-1
EOL	End of Life	5-4
FET	Field Effect Transistor	4-24
FSK	Frequency Shift Keying	4-19
FTP	File Transfer Protocol	3-1
GUI	Graphic User Interface	5-3
IPA	IP Address	4-9
LNB	Low Noise Block Down Converter	1-1
LRS	Local Remote Status	4-8
M&C	Monitor and Control	1-2
MCP	Monitor/Control Processor	1-2
MIB	Management Information Base	4-1
MOP	Maximum Operating Point	4-26
MTBF	Mean Time Between Failures	1-2
NMS	Network Management System	4-1
OID	Object Identifier	4-2
OXCO	Oven-controlled Crystal Oscillator	1-3
PC	Personal Computer	3-1
QO	Query Operator	5-6
RF	Radio Frequency	1-1
SNG	Satellite News Gathering	1-2
SNMP	Simple Network Management Protocol	4-1
SSPA	Solid State Power Amplifier	1-2
TWT	Traveling Wave Tube	1-1
VSWR	Voltage Standing Wave Ratio	1-3

## Units of Measurement

Unit / Symbol	Definition
Ω	Ohm
A	Ampere
bps	bits per second
°C	Celsius (degrees)
Hz	Hertz
kHz	kiloHertz
dB	decibel
dBc	Decibels relative to the carrier
dBm	Decibel-milliwatts
°F	Fahrenheit (degrees)
Kbps	Kilobit per second
kg	kilogram
ksps	Kilosymbols per second
lbs.	pounds
mA	Milli-amp
Mbps	Megabit per second
MHz	Megahertz
mm	millimeter
ms	millisecond
MspS	Megasymbols per second
mW	milliwatt
in.	inch
Ppm	Packets per minute
Pps	Packets per second
SR	Symbols per second
μF	100 micro-farads
W	Watt
V	Volt



# PREFACE

---

## About this Manual

This manual provides installation and operation information for the Comtech EF Data (CEFD) L GaN family of Outdoor Amplifiers / Block Up Converter (BUCs). This document is intended for the persons responsible for the operation and maintenance of the L GaN.

## Related Documents

- CEFD CLC-10 Handheld Terminal M&C Accessory for LPOD or SPOD PS 1, PS 1.5, PS 2 User's Guide (CEFD P/N MN-CLC10)
- CEFD LPOD<sub>net</sub> M&C Netbook Accessory for LPOD or SPOD PS 1, PS 1.5, PS 2 Operation Manual (CEFD P/N MN-LPODNET)
- CEFD RF Control – Transceiver/Amplifier M&C Utility User Guide (CEFD P/N MN-CRFC)

## Disclaimer

Comtech EF Data has reviewed this manual thoroughly in order to provide an easy-to-use guide to this equipment. All statements, technical information, and recommendations in this manual and in any guides or related documents are believed reliable, but the accuracy and completeness thereof are not guaranteed or warranted, and they are not intended to be, nor should they be understood to be, representations or warranties concerning the products described. Further, Comtech EF Data reserves the right to make changes in the specifications of the products described in this manual at any time without notice and without obligation to notify any person of such changes.

If there are any questions regarding this equipment or the information in this manual, please contact Comtech EF Data Product Support.

---

## Conventions and References

### Patents and Trademarks

See all of Comtech EF Data's Patents and Patents Pending at <http://patents.comtechefdata.com>.

Comtech EF Data acknowledges that all trademarks are the property of the trademark owners.

## Warnings, Cautions, Notes, and References



A **WARNING** indicates a potentially hazardous situation that, if not avoided, could result in death or serious injury.



A **CAUTION** indicates a hazardous situation that, if not avoided, may result in minor or moderate injury. **CAUTION** may also be used to indicate other unsafe practices or risks of property damage.



A **NOTE** gives you important information about a task or the equipment.



A **REFERENCE** directs you to important operational information or details furnished elsewhere, either in the manual or in adjunct Comtech EF Data publications.

## Examples of Multi-Hazard Notices

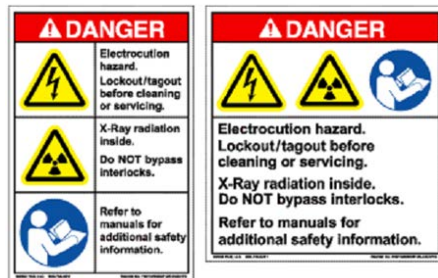

## Recommended Standard Designations

Electronic Industries Association (EIA) designations supersede Recommended Standard (RS) designations. Reference to the old RS designations may appear where it might concern actual text (e.g., RS-232) displayed on the product panels and on screens or pages in the Serial Remote or HTTP (Web Server) Interfaces. All other references in the manual refer to EIA designations.



### CAUTION

It is important that you review and understand the **Safety and Compliance** information that follows.

---

## Safety and Compliance

### Electrical Safety and Compliance



**CAUTION**  
**NEUTRAL FUSING – DOUBLE POLE/NEUTRAL FUSING IS USED ON THE PRIME POWER SUPPLY INPUT.**

This equipment has been designed to minimize exposure of personnel to hazards. For further information, contact Comtech EF Data Product Support. The operators and technicians must:

- Know how to work around, with, and on high voltage equipment.
- Exercise every precaution to ensure personnel safety.
- Exercise extreme care when working near high voltages.
- Be familiar with the warnings presented in this manual.

---

### Installation Guidelines Regarding Power Line Quality



**Comtech EF Data has become familiar with the varying quality of the AC power grid around the world. Observing the following installation guidelines should help ensure a reliable installation.**

- **Surge suppression** – High voltage surges can cause failure of the power supply. These surges are typically caused by circuit switching on the main AC power grid, erratic generator operation, and also by lightning strikes. While the LGaN does have built in surge suppression, if the unit is to be installed in a location with questionable power grid quality, Comtech EF Data recommends installation of additional power conditioning/surge suppression at the power junction box.
- **Grounding** – The LGaN provides a grounding terminal. This is provided to allow you to ground the LGaN to the antenna's grounding network. All components installed at the antenna should be grounded to a common grounding point at the antenna.
- **Electrical welding** – If welding needs to take place at the antenna, disconnect all cables from the LGaN except for the ground wire. Cap all RF connections with terminations. This will prevent damage to the input/output circuitry of the LGaN.
- **Lightning** – Lightning strikes on or around the antenna will generate extremely high voltages on all cables connected to the LGaN. Depending on the severity of the strike, the LGaN's internal surge protection combined with the recommended external suppression may protect the LGaN's power supply. However, if the installation will be in an area with a high probability of lightning strikes, Comtech EF Data recommends the installation of surge suppression on the RF and IF cables. One source of these suppressors is PolyPhaser ([www.polyphaser.com](http://www.polyphaser.com)).

---

## Product Support

For all product support, please call:

+1.240.243.1880

+1.866.472.3963 (toll free USA)

---

## Comtech EF Data Headquarters

<http://www.comtechefdata.com>

Comtech EF Data Corp.  
2114 West 7th Street  
Tempe, Arizona USA 85281  
+1.480.333.2200

---

## Warranty Policy

Comtech EF Data products are warranted against defects in material and workmanship for a specific period from the date of shipment, and this period varies by product. In most cases, the warranty period is two years. During the warranty period, Comtech EF Data will, at its option, repair or replace products that prove to be defective. Repairs are warranted for the remainder of the original warranty or a 90 day extended warranty, whichever is longer. Contact Comtech EF Data for the warranty period specific to the product purchased.

For equipment under warranty, the owner is responsible for freight to Comtech EF Data and all related customs, taxes, tariffs, insurance, etc. Comtech EF Data is responsible for the freight charges only for return of the equipment from the factory to the owner. Comtech EF Data will return the equipment by the same method (i.e., Air, Express, Surface) as the equipment was sent to Comtech EF Data.

All equipment returned for warranty repair must have a valid RMA number issued prior to return and be marked clearly on the return packaging. Comtech EF Data strongly recommends all equipment be returned in its original packaging.

Comtech EF Data Corporation's obligations under this warranty are limited to repair or replacement of failed parts, and the return shipment to the buyer of the repaired or replaced parts.

## Limitations of Warranty

The warranty does not apply to any part of a product that has been installed, altered, repaired, or misused in any way that, in the opinion of Comtech EF Data Corporation, would affect the reliability or detracts from the performance of any part of the product, or is damaged as the result of use in a way or with equipment that had not been previously approved by Comtech EF Data Corporation.

The warranty does not apply to any product or parts thereof where the serial number or the serial number of any of its parts has been altered, defaced, or removed. The warranty does not cover damage or loss incurred in transportation of the product. The warranty does not cover replacement or repair necessitated by loss or damage from any cause beyond the control of Comtech EF Data Corporation, such as lightning or other natural and weather related events or wartime environments.

The warranty does not cover any labor involved in the removal and or reinstallation of warranted equipment or parts on site, or any labor required to diagnose the necessity for repair or replacement.

The warranty excludes any responsibility by Comtech EF Data Corporation for incidental or consequential damages arising from the use of the equipment or products, or for any inability to use them either separate from or in combination with any other equipment or products.

A fixed charge established for each product will be imposed for all equipment returned for warranty repair where Comtech EF Data Corporation cannot identify the cause of the reported failure.

## Exclusive Remedies

Comtech EF Data Corporation's warranty, as stated is in lieu of all other warranties, expressed, implied, or statutory, including those of merchantability and fitness for a particular purpose. The buyer shall pass on to any purchaser, lessee, or other user of Comtech EF Data Corporation's products, the aforementioned warranty, and shall indemnify and hold harmless Comtech EF Data Corporation from any claims or liability of such purchaser, lessee, or user based upon allegations that the buyer, its agents, or employees have made additional warranties or representations as to product preference or use.

The remedies provided herein are the buyer's sole and exclusive remedies. Comtech EF Data shall not be liable for any direct, indirect, special, incidental, or consequential damages, whether based on contract, tort, or any other legal theory.

# Chapter 1. INTRODUCTION

---

## 1.1 Overview

Comtech EF Data's (CEFD) L-GaN family of Outdoor Amplifiers / Block Up Converters (BUCs) – referred to collectively throughout this manual as the **LGaN** – deliver their rated power, guaranteed, to the transmit waveguide flange. The LGaN provides a cost effective, more reliable replacement for Traveling Wave Tube (TWT) amplifiers in satellite communications.

CEFD's extensive experience in the design of outdoor Radio Frequency (RF) transceivers led to the LGaN family's efficient thermal and mechanical package. Recognizing the evolution of L-Band IF systems, the LGaN is designed to eliminate the traditional requirement for the modem to supply a Direct Current (DC) power source and a 10 MHz reference to the BUCs and Low Noise Block Down Converters (LNBS).



Figure 1-1. LGaN Outdoor Amplifier/ BUC (50 W)



Figure 1-2. LGaN Outdoor Amplifier/ BUC (100 W)

---

## 1.2 Functional Description

The compact size and weight of the L-GaN lends itself to any installation with limited available mounting space. These include ship-borne antenna systems, small “flyaway” systems, and Satellite News Gathering (SNG) installations. The addition of the optional internal reference and LNB bias T facilitates multi-carrier and redundant operations required of small-to medium-sized hub installations.

As shown in Figure 1-1 and Figure 1-2, CEFD’s L-GaN is available in several sizes and power levels. Each L-GaN consists of a CEFD Solid State Power Amplifier (SSPA) module with the Monitor/Control Processor (MCP), a power supply, and a fan assembly. The amplifier features a CEFD low loss combining technique and MCP-based temperature-versus-gain compensation.

---

## 1.3 Features

### 1.3.1 The Solid-State Advantage

The L-GaN is constructed with highly reliable gallium nitride field-effect transistors (GaN FETs). The L-GaNs also provide mean time between failures (MTBF) that is four to five times greater than the typical TWT MTBF.

### 1.3.2 Monitor and Control (M&C)

The L-GaN includes a microprocessor-based system that provides monitoring and control of the essential parameters of the unit. The user interfaces with the unit through the M&C system via the remote control/discrete communications port.

The unit is capable of EIA-232, EIA-485, or Ethernet remote communication. A discrete mute control and relay status output is also available.

The M&C system monitors the fan speed, unit temperature, all power supply voltages, power transistor currents, output power, etc. Should a critical monitored parameter fail, the unit will mute the RF signal and report a fault. The details of the fault can be accessed via remote communication.

### 1.3.3 Enhanced Standard Features

The L-GaN comes equipped with useful features that other manufacturers offer only as options. Included in the base price are temperature compensation, sample ports (on some models), power monitor, power factor corrected supply, and full remote monitor and control (M&C) capabilities (including Ethernet and serial).

### 1.3.4 “Smart BUC” Functionality

CEFD’s unique approach to L-Band/RF frequency conversions eliminates DC and 10 MHz from the input coax. This simplifies redundant and multi-carrier operation. All units support industry standard FSK modem/BUC communications.

All L-GaN models have a self-contained power supply, eliminating the requirement for the modem to supply the BUC voltage on the center conductor of the RF cable, simplifying multi-carrier operation and modem spares maintenance.



### 1.3.5 Data Logging Capability

To greatly enhance system maintainability, the L-GaN includes a built-in data logging capability. By recording critical operational parameters (such as temperature, output power, mute status, etc.) at time stamped intervals, the user can quickly gather intelligence not only about the unit itself, but also the unit's operational environment.

### 1.3.6 Optional Internal 10 MHz Reference

With the optional high stability, oven-controlled crystal oscillator (OCXO) installed, one more signal is removed from the Tx IF cable. This ensures optimum RF performance of the BUC by eliminating any reference degradation caused by IF combiners, interconnections, or rotary joints.

### 1.3.7 Optional LNB Support

The L-GaN was designed with the evolution of L-band systems in mind. L-band IF topologies are no longer relegated to low power single carrier installations and are now found in larger multi-carrier installations. A challenge presented by multi-carrier L-band systems is the presence of DC and reference components on the Tx/Rx L-band interfaces. The L-GaN design, by default, eliminates the DC component from the Tx IF and can eliminate the reference requirement with the optional internal OCXO. The LNB bias/reference option completes the solution by eliminating DC and reference signal requirements from the Rx L-band interface.

### 1.3.8 SSPA Module

The amplifier module performs the core function of the unit. An isolator is at the RF input to ensure good voltage standing wave ratio (VSWR). The RF signal then passes through an electronically controlled attenuator that adjusts the overall attenuation according to the user input. After some amplification, a second attenuator is automatically controlled via a look-up table to maintain the amplifier gain at a constant level over temperature variations.

The RF signal is then amplified by a multi-stage design that utilizes proprietary combining techniques to meet the rated power requirements. The output circuitry contains a coupler to provide a sampled signal for monitoring purposes. A power detector circuit also is included, and the reading can be accessed via remote communication. A high-power circulator and load are located at the output to provide good VSWR and protection from external mismatch.

### 1.3.9 Cooling System



## Chapter 2. SYSTEM CONNECTORS, INSTALLATION AND STARTUP

The L-GaN contains a robust heat sink and thermal design to maintain a low operating temperature. All contain temperature-controlled fans which are monitored by the M&C board. The fans draw in cool outside air across the power supply and specialized RF heat sink. The amplifier module temperature is monitored and, if for any reason the amplifier temperature exceeds a safe preset limit, the amplifier module supply is shut down to protect the unit from thermal failure.

Most L-GaN units monitor the ambient (outside) air temperature through a sensor located in the air intake. An alarm is generated if the ambient temperature rises at least 3°C (37.4°F) above the specified upper limit. Additionally, the unit will shut down to protect itself if an ambient temperature of 6°C (42.8°F) above the specified upper limit is detected.

The LGaN should be installed in a way which does not impede adequate airflow (see **Chapter 2. SYSTEM CONNECTORS, INSTALLATION AND STARTUP**), and the unit should always be operated within its specified temperature range. The LGaN's heatsinks should also be cleaned regularly to ensure optimal airflow and cooling performance.

### 1.3.10 Temperature and RF Overdrive



**Read and understand this important section to ensure long time amplifier reliability.**

---

#### 1.3.10.1 Overview

The LGaN has firmware intended to help the user be more aware of potential over temperature and over drive conditions that could degrade the reliability of the amplifier. Furthermore, the user can view recorded maximum and minimum values of important parameters as they have occurred over the operating history of the unit. These updates are explained below.

---

#### 1.3.10.2 Over Temperature



**Chapter 4. ETHERNET INTERFACE OPERATION, Section 4.5.4.2, Status | Status**

Operating the LGaN beyond its specified temperature rating may degrade the performance and life of the unit. The unit has an internal sensor that monitors the temperature of the airflow across the cooling fans and is very close to the actual ambient or outside temperature. This temperature can be monitored on the **Status | Status** webpage. It is also reported via the serial RMS command, and has the label of Outside Temperature (OTEMP). This temperature should be consistent with the expected ambient temperature in which the unit resides. If it is not, then the user should ensure that there are no obstructions blocking the cool air inlet or recirculating the hot air exhaust of the unit back into the inlet, that there is adequate clearance around the cool air inlet and exhaust areas, and that all fans are working properly, etc.

If the ambient temperature is measured at least 3°C (37.4°F) above the specified rating, or other internally monitored temperatures exceed their threshold (such as the amplifier heat sink temperature, ATEMP>95°C (203°F)), an alarm or fault will be declared. The unit will not shut down, but the condition causing the elevated temperature should be promptly remedied. If temperatures continue to rise (Outside Temp ≥6°C (42.8°F) above rated, or ATEMP ≥96°C (204.8°F)), the unit will declare an Over Temperature Shutdown fault and will turn off the power supplies to the critical RF transistors for protection purposes. (The Amplifier/Outside Temperature Alarm has a hysteresis of 5°C (41°F), while the Over Temperature Shutdown fault has a hysteresis of 10°C (50°F)).

### 1.3.10.3 Over Drive (Excessive RF Input Level)

The unit's specified linear rated output power level, Plinear, can be found in the unit datasheet. Although the unit may be capable, operating beyond its Plinear level is discouraged. As the input drive level is increased, output saturation will soon be reached where device currents and temperatures may rise very quickly to disconcerting levels, but without any appreciable increase in usable output power.

Although the best protection against potentially degrading overdrive conditions is user attention and vigilance to the input and output levels as mentioned above, CEFD has implemented software failsafes which will help protect the unit from damage and warn the user of gross overdrive conditions. The over drive information is displayed on the Status webpage.

When an excessive output power level is detected, the unit begins adding attenuation and will eventually declare an alarm when the over drive condition exceeds 1.0 dB. If this occurs, the user should reduce the input power until the alarm clears and the estimated overdrive is 0 dB. (Note that once the over drive alarm is active, the input power level must be reduced until the output power is 5 dB below the Prated level before the over drive attenuation is released and the alarm is cleared.) Additionally, a fault condition is raised if the over drive attenuation level reaches 10 dB. This fault will turn off the power supplies to the critical RF transistors for protection purposes.

### 1.3.11 Maximum Operating Points



#### Chapter 4. ETHERNET INTERFACE OPERATION, Section 4.5.4.2, Status | Status

The **Status | Status** webpage includes the maximum (and in some cases, minimum) operating points of key parameters as they are recorded by the unit over time. This helps the factory and the user ensure that the unit is being operated correctly, especially regarding ambient temperature and user drive levels.

### 1.3.12 Power Supply

The LGaN features a power supply that is power factor corrected. It supplies several voltages necessary for the unit to operate.

### 1.3.13 LNB Operation

Either LGaN package style may be ordered with an optional internal 10 MHz reference and LNB converter bias tee. With these options installed, the user has control of the bias tee enable (LNB On/Off) as well as the DC bias voltage (On/Off).

### 1.3.14 Block Up Converter (BUC) Input

The LGaN upconverts an L-Band input carrier to the desired output frequency (C, X, or Ku-Band). LO frequencies are provided in the table below:

BUC C, Ku, X LO Frequencies			
Band	Frequency	LO Frequency	Inverting
C-Band	5850 to 6650 MHz	4900 MHz	No
	5950 to 6700 MHz	5000 MHz	No
Insat C-Band	6725 to 7025 MHz	5760 MHz	No
X-Band	7900 to 8400 MHz	6950 MHz	No
Ku Band (Low)	12.75 to 13.25 GHz	11.800 GHz	No
Ku-Band	14.00 to 14.50 GHz	13.050 GHz	No
Ku-Band-W	13.75 to 14.50 GHz	12.800 GHz	No

Unlike most BUCs, no DC bias voltage should be provided on the center conductor of the L-Band coax. In addition, the LGaN is available with an internal 10 MHz reference. As such, no 10 MHz reference is required on the center conductor of the L-Band coax. If a reference is provided on the coax, the internal reference will detect and lock to it.

## 1.4 Dimensional Envelopes



*Typical for all figures in each subsection, all dimensions are in inches. Bracketed dimensions, where shown, are in metric units (mm).*

*Unless otherwise noted, all figures depict AC Option, Waveguide Output units.*

### 1.4.1 L-GaN 50 W Dimensional Envelopes

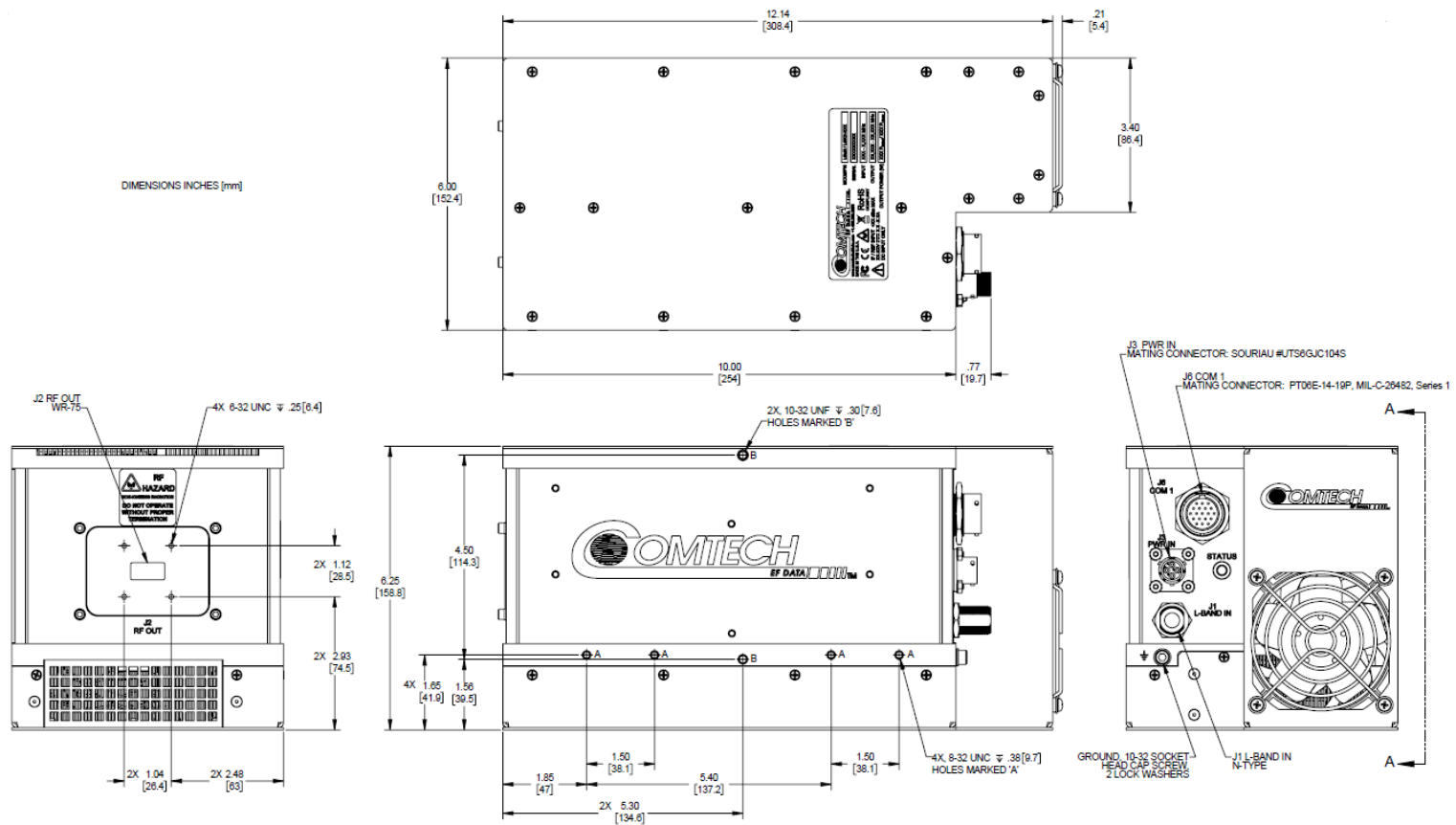

Figure 1-3. L-GaN 50 W Dimensional Envelope (1 of 2)

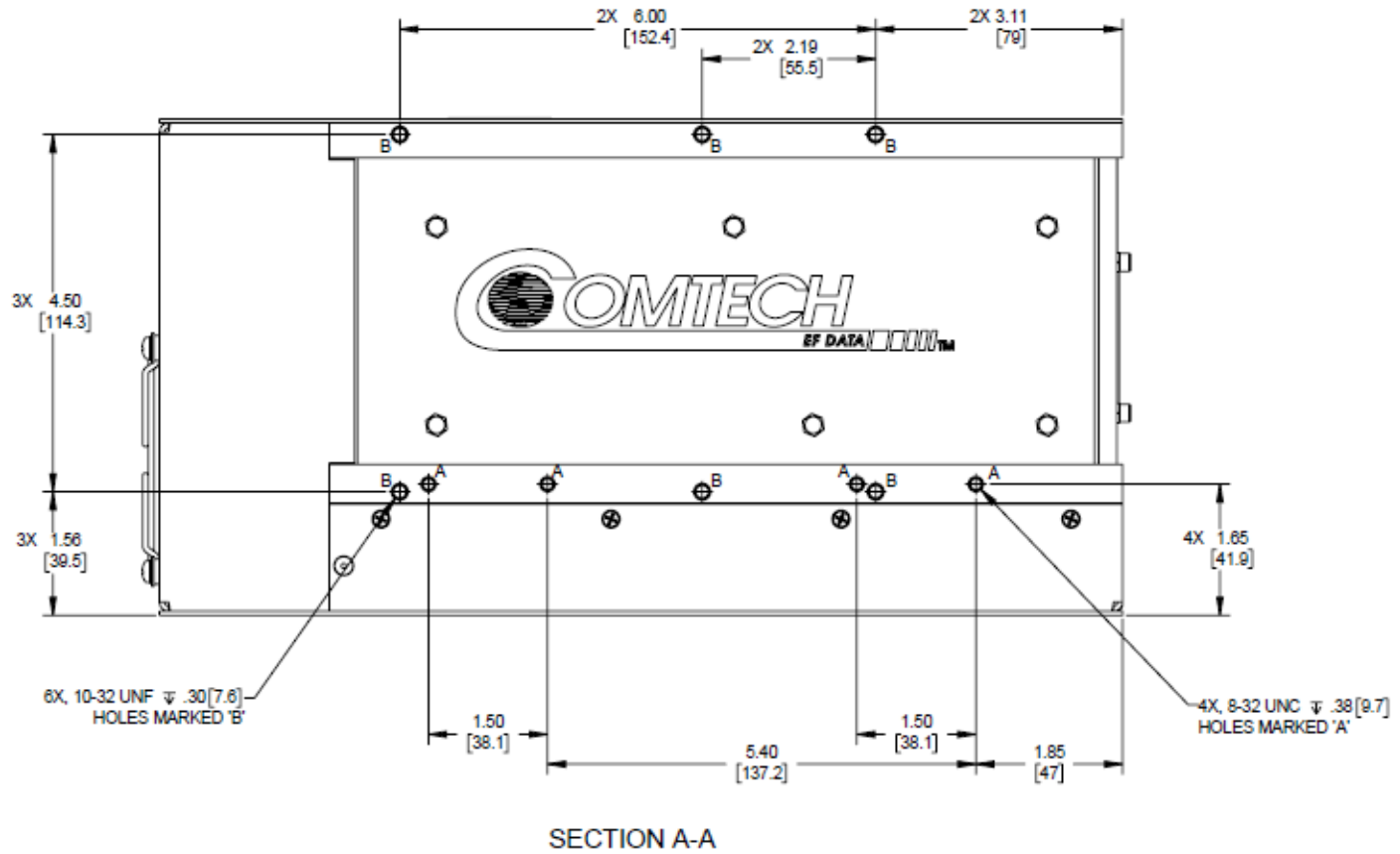

Figure 1-4. L-GaN 50 W Dimensional Envelope (2 of 2)

### 1.4.2 L-GaN 100 W Dimensional Envelopes

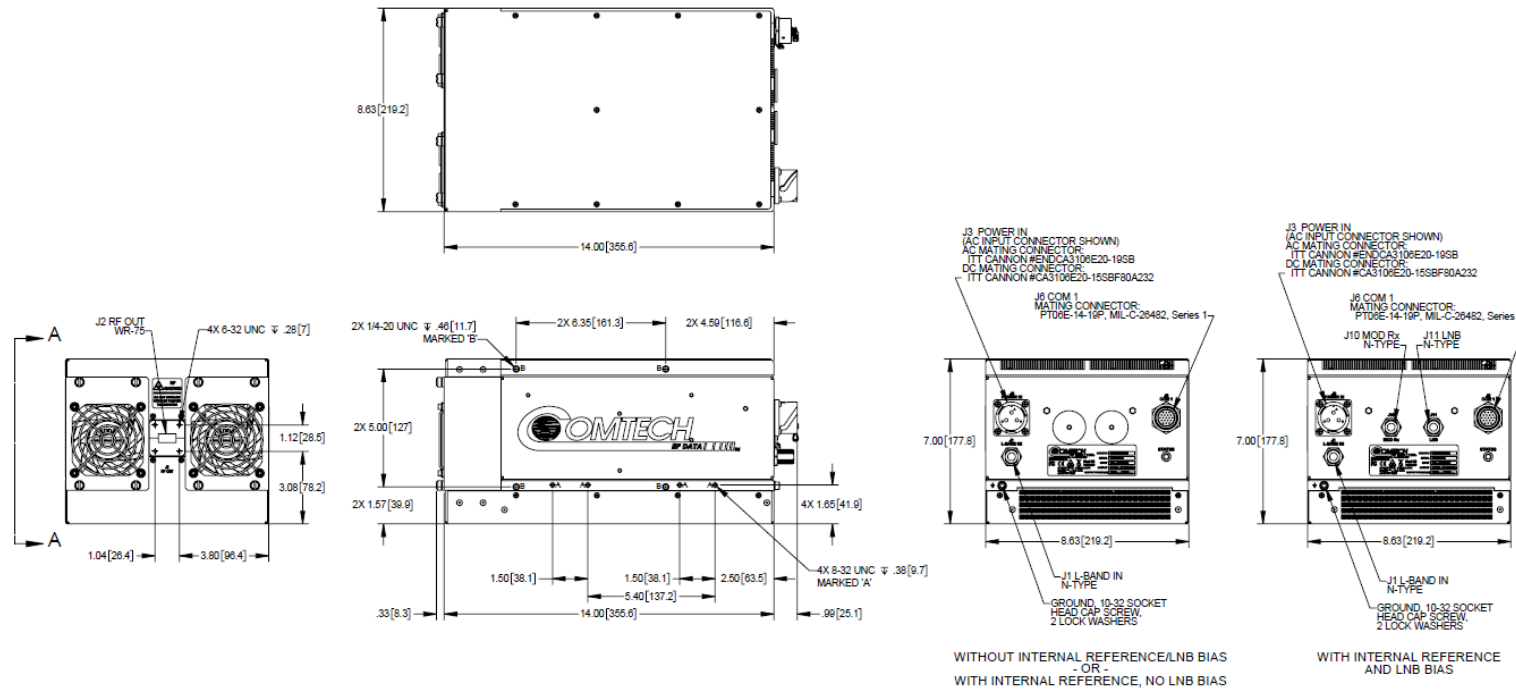

Figure 1-5. L-GaN 100 W Ku-Band Dimensional Envelope (1 of 2)

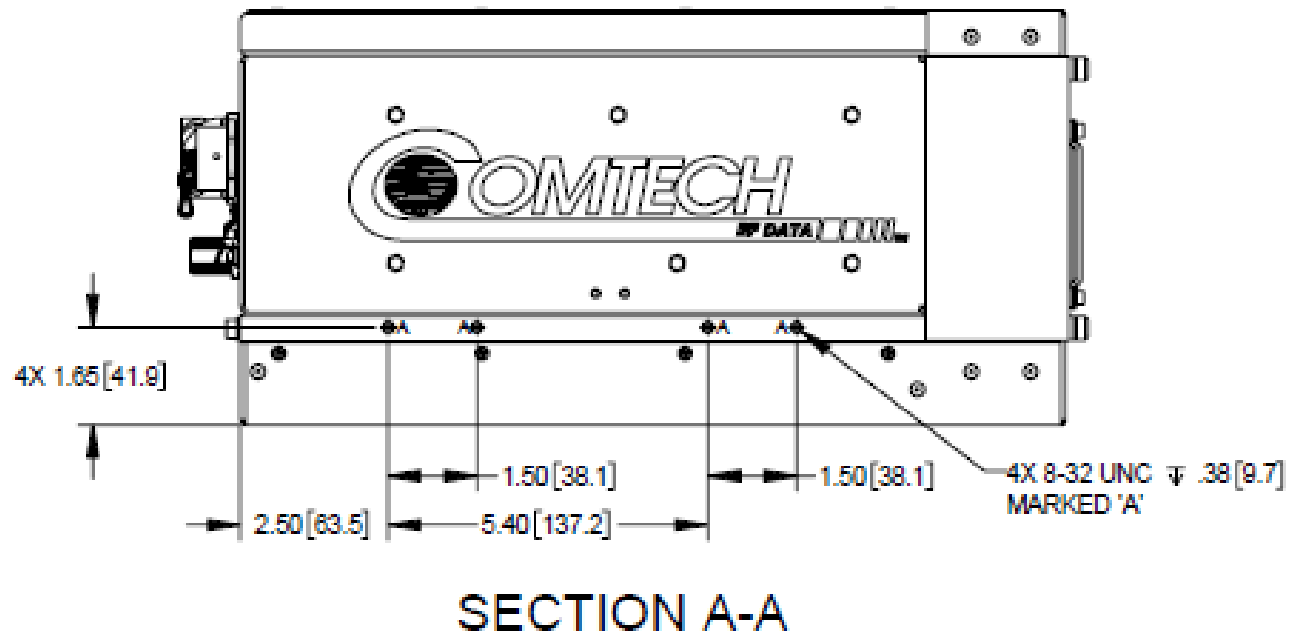

Figure 1-6. L-GaN 100 W Ku-Band Dimensional Envelope (2 of 2)



# Chapter 2. SYSTEM CONNECTORS, INSTALLATION, AND STARTUP

---

## 2.1 Overview



- **Chapter 4. ETHERNET INTERFACE OPERATION.** See for information about using the LGaN's remote Ethernet M&C functionality.
- **Chapter 5. SERIAL INTERFACE OPERATION.** See for information about using serial-based remote commands and queries.
- **Appendix A. 1:1 REDUNDANCY.** See for detailed information for installing and using the LGaNs in a 1:1 redundancy configuration.

This chapter provides user reference to the following:

- The LGaN connectors for signal input, signal output; M&C of the unit; and grounding of the unit to the antenna's grounding network.
- Available standalone installation kits.
- Instructions for installation and startup.

## 2.2 Water Tight Sealing



All external cable assemblies for the outdoor equipment **MUST** be properly sealed to prevent water intrusion. Failure to achieve water tight sealing will result in possible performance degradation and even product failure.

**IMPORTANT:** To maintain your product warranty, you must follow these guidelines and recommendations during equipment installation:

- Make sure all external connections to the equipment are hand-tightened and wrapped with a self-amalgamating tape such as **3M Type 23 Scotch Self-Amalgamating Tape** (or equivalent). The sealing must cover the external connector housing and extend beyond the end of the heatshrink that covers the connector termination of the cable assembly.
- Squeeze the self-amalgamating tape tightly and make sure both ends of the tape have formed around the connector and cable to create a water tight seal.
- ALL unused external connectors **MUST** be covered with caps and sealed. Make sure to inspect the connector cap rubber seal for cracks before using.

### 2.2.1 Customer Cable Assemblies



Should you receive an accessory kit that contains only the mating cable connectors, or if you (the end-user) choose to supply your own cables and connectors, CEFD strongly recommends that you use an adhesive lined heatshrink such as TE Connectivity #ATUM-24/6-0 (or equivalent) to cover the connector strain-relief area. Your sealed, water tight cable ends should appear as per this example:



## 2.3 Connectors and Cables

The LGaN external connectors provide all necessary connections between the LGaN 50 W (Figure 2-1), or the LGaN 100 W (Figure 2-2) models and other equipment.

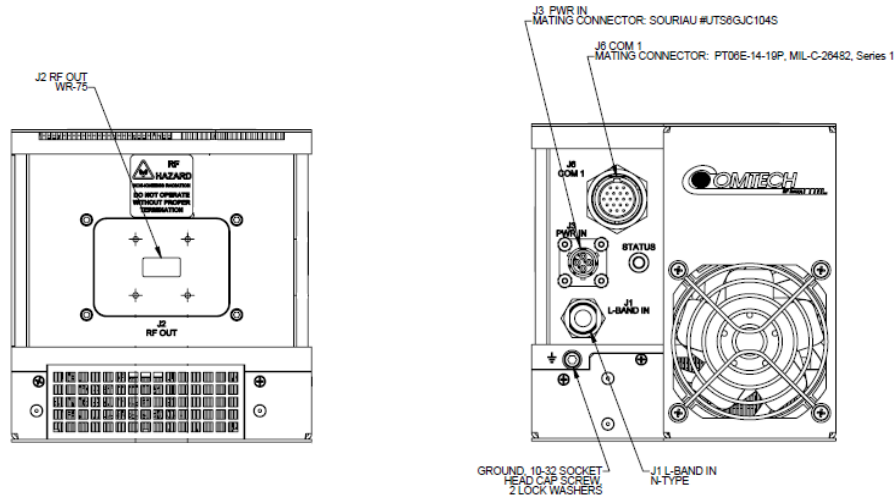

Figure 2-1. LGaN 50 W Connectors

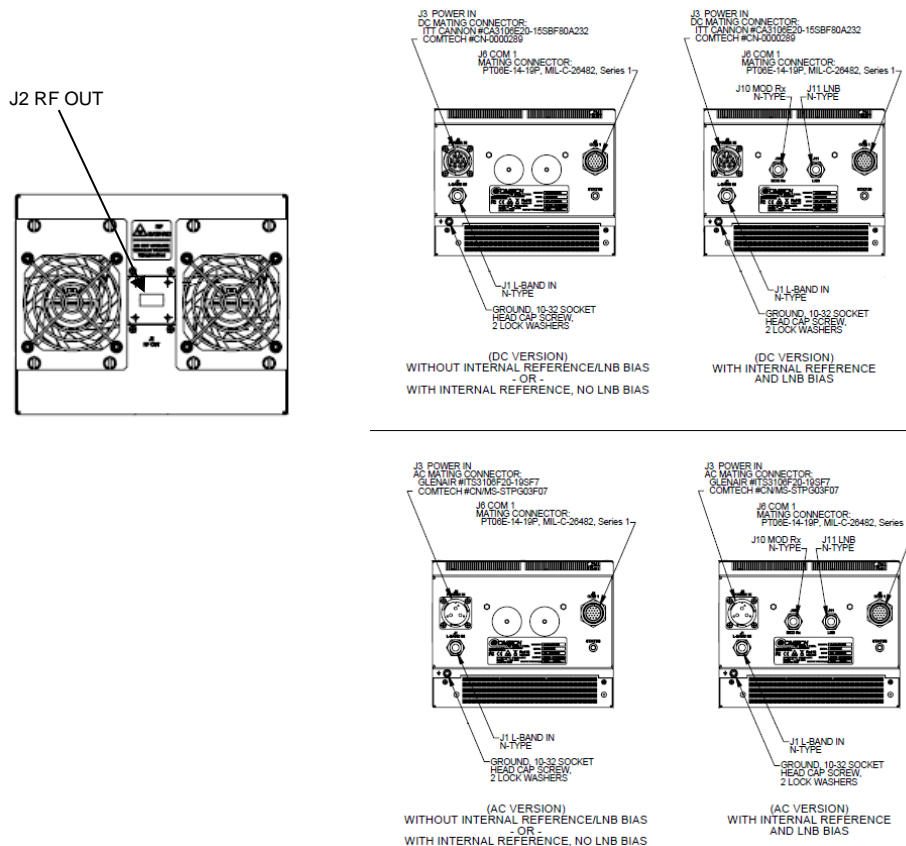
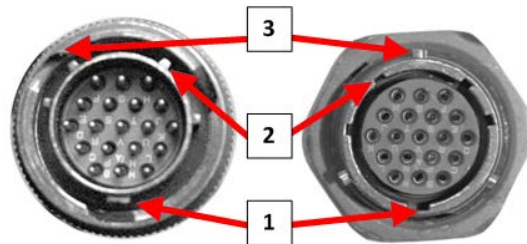

Figure 2-2. LGaN 100 W Connectors

### About Circular Connectors

The connector pairs (Figure 2-3) feature a sleeve lock configuration, with an array of pins (male side) coupled to mating sockets (female side).



Feature	Description
1	Primary Alignment features
2	Secondary Alignment features
3	Sleeve Lock features

**Figure 2-3. Circular Connector Example**

**Connection Instructions** – Engage all the alignment and lock features between the male connector (on the interconnection cable) and female socket. To install the male connector into the female connector, do these steps:

**Step 1** – Engage the primary and secondary alignment tabs on the male connector with the mating cutouts on the female socket.

**Step 2** – Push the male connector into the female socket.

**Step 3** – Turn the male connector sleeve clockwise until the sleeve lock cutouts engage fully with the female socket tabs and you hear a “click” sound.

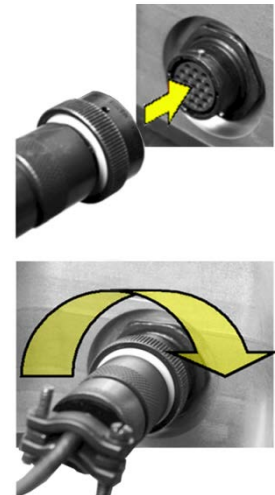

### 2.3.1 Connector ‘J1 | LBAND IN’ or ‘J1 | Tx IN’



The RF input connector is a Type ‘N’ female connector. Labeled ‘**J1 | LBAND IN**’ on the L GaN 50 W and 100 W models, typical input levels (-30 dBm) depend on desired output power and unit attenuation. To prevent damage to the L GaN, RF input levels should not exceed +15 dBm.

### 2.3.2 Connector ‘J2 | RF OUT’



**FOR SAFETY REASONS, NEVER LOOK DIRECTLY INTO THE WAVEGUIDE OUTPUT.**

The ‘**J2 | RF OUT**’ connector will be waveguide appropriate to the frequency of the unit Connector ‘**J3 | POWER IN**’ AC Power Mains



**FOR SAFETY REASONS, MAKE SURE YOU KNOW THAT THE ‘J3 | POWER IN’ AC POWER CONNECTION PIN ASSIGNMENTS ARE DIFFERENT FOR EACH LGAN UNIT. YOU MUST USE THE CORRECT PIN ASSIGNMENTS.**

**INCORRECT USE OF PIN ASSIGNMENTS CAN RESULT IN PRODUCT DAMAGE OR PERSONAL INJURY.**

For all L GaN models, the prime power input requirement is as follows:

- 90 to 264 VAC
- 47 to 63 Hz

The power supply is power factor corrected. The total power required from the prime power supply depends on the model used. See **Sect. 1.5 Summary of Specifications** for more information.

## 2.3.3 Connector ‘J3 | POWER IN’

### 2.3.3.1 Connector ‘J3 | POWER IN’ AC Power Main – 100 W

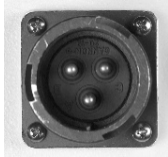

The mating connector specification and pin assignments specific to the LGaN 100 W power interfaces are as follows:

**Mating Connector:** Glenair ITS-3106F20-19SF7  
(CEFD PN CN/MS-STPG03F07)

**Table 2-1. Connector ‘J3 | POWER IN’ Pin Assignments – 100 W**

Pin	Description
A	GND
B	NEUTRAL (L2)
C	LINE (L1)

### 2.3.3.2 Connector ‘J3 | POWER IN’ DC Power Mains



**FOR SAFETY REASONS, MAKE SURE YOU KNOW THAT THE ‘J3 | POWER IN’ DC POWER CONNECTION PIN ASSIGNMENTS ARE DIFFERENT FOR EACH LGaN UNIT. YOU MUST USE THE CORRECT PIN ASSIGNMENTS.**

**INCORRECT USE OF PIN ASSIGNMENTS CAN RESULT IN PRODUCT DAMAGE OR PERSONAL INJURY.**

The prime power input requirement for the for the LGaN 50 W is 36 to 60 VDC and for the LGaN 100 W is 36 to 72 VDC. The total power required from the prime power supply depends on the model used. See **Sect. 1.5 Summary of Specifications** for more information.

#### 2.3.3.2.1 Connector ‘J3 | POWER IN’ DC Power Main – 50 W

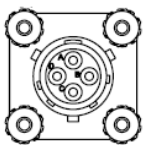

The mating connector specification and the pin assignments (Table 2-2) specific to the LGaN 50 W DC power interface are as follows:

**Mating Connector:** SOURIAU #UTS6GJC104S  
(CEFD PN CN-0021091)

**Table 2-2. LGaN 50 W ‘J3 | POWER IN’ Pin Assignments**

Pin	LGaN 50 W Assignment
A	V+
B	V+
C	V-
D	V-

### 2.3.3.2.2 Connector ‘J3 | POWER IN’ DC Power Main – 100 W



The mating connector specification and the pin assignments specific to the LGaN 100 W DC power interface are as follows:

**Mating Connector:** ITT Cannon #CA3106E20-15SBF80A232  
(CEFD PN CN-0000289)

**Table 2-3. LGaN 100 W ‘J3 | POWER IN’ Pin Assignments**

Pin	LGaN 100 W Assignment
A	V+
B	V+
C	N/C
D	N/C
E	V-
F	V-
G	GND

### 2.3.4 Connector ‘J6 | COM1’ (Remote Communications and Discrete Control Port)



This connector is used for all LGaN products.

The ‘J6 | COM 1’ discrete control connector is the primary input for controlling and monitoring the LGaN 50 W / 100 W units. It is a 19-pin circular connector, type MS3112E14-19S.

**Mating connector:** PT06E-14-19P, MIL-C-26482, Series 1 (CEFD PN 28P1038)

**Table 2-4. LGaN ‘J6 | COM1’ Pin Assignments**

Pin	Name	Description
A	RS485_+RX	
B	RS485_-RX	
C	RS485_+TX	
D	RS485_-TX	
E	RS232_RD	Pin 3 of DB9 female connector
F	Ethernet TX+	Pin 3 of RJ45 female connector
G	RS232_TD	Pin 2 of DB9 female connector
H	Ethernet TX-	Pin 6 of RJ45 female connector
J	TX/RX Switch Drive 1 Pos	<b>Not for customer use</b>
K	GND	Ground (also Pin 5 of DB-9F connector)
L	SUMFLT In	Open when faulted, else +5VDC
M	SUMFLT Out	When faulted, tied to Pin K, else open
N	TX Switch Pos 1 Ind	Online/Offline indication
P	RX Switch Pos 1 Ind	<b>Not for customer use</b>
R	+24V	<b>Not for customer use</b>
S	System Mute Control	When <b>AUX=1</b> , unit is muted until this pin is tied to ground (Pin K). When tied to ground, the unit unmutes. See the AUX remote command in <b>Chapter 5. SERIAL INTERFACE OPERATION</b> .
T	Switch Common	GND reference for Pin N
U	Ethernet RX-	Pin 2 of RJ45 female connector
V	Ethernet RX+	Pin 1 of RJ45 female connector



### 2.3.5 Connector ‘J10 | MOD Rx’ – 100 W



The MOD RF input connector is a Type ‘N’ connector used for internal references on 100 W units.

### 2.3.6 Connector ‘J11 | LNB’ – 100 W



The LNB input connector is a Type ‘N’ connector used for LNB Bias on 100 W units.

### 2.3.7 Ground Connector



Use this #10-32 hardware, available where shown in Figure 2-4, to connect a common chassis ground among equipment (Hardware is 10-32 socket head cap screw and internal star washers for both the 50W and 100W).

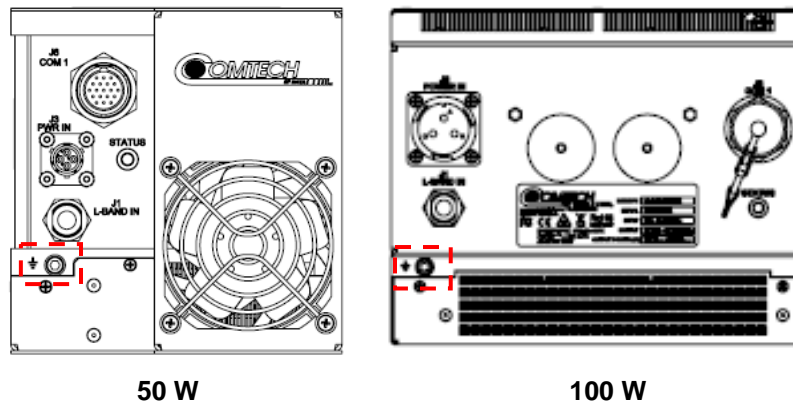
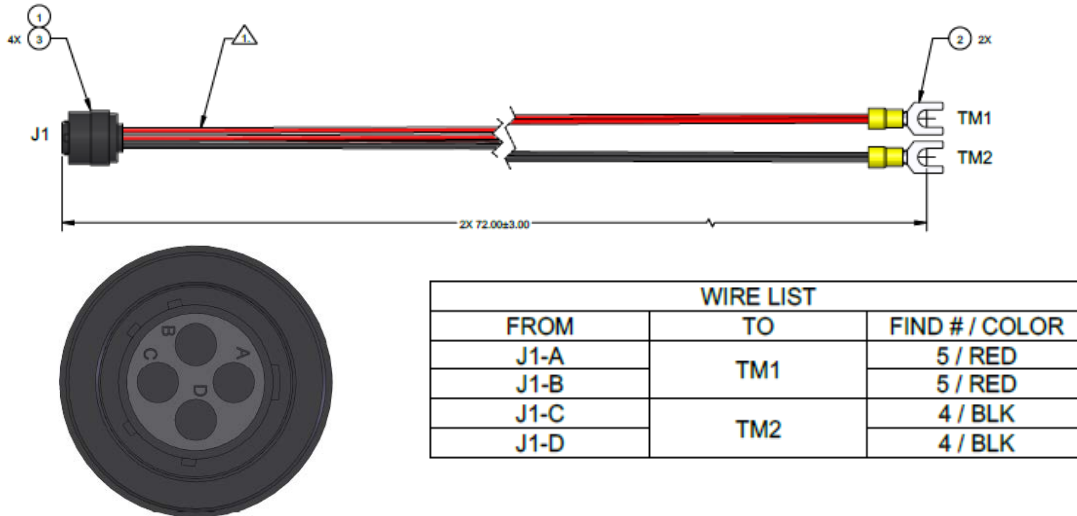

Figure 2-4. LGaN Ground Connector Locations

## 2.3.8 BUC DC Power Supply Cable

### 2.3.8.1 DC Power Supply Cable – 50 W

Mating connectors are provided. **OPTIONAL:** As an alternate, the following cable can be purchased from Comtech EF Data, part number CA-0021705.



### 2.3.8.2 DC Power Supply Cable – 100 W

Mating connectors are provided. **OPTIONAL:** As an alternate, the following cable can be purchased from Comtech EF Data, part number CA-0021917.

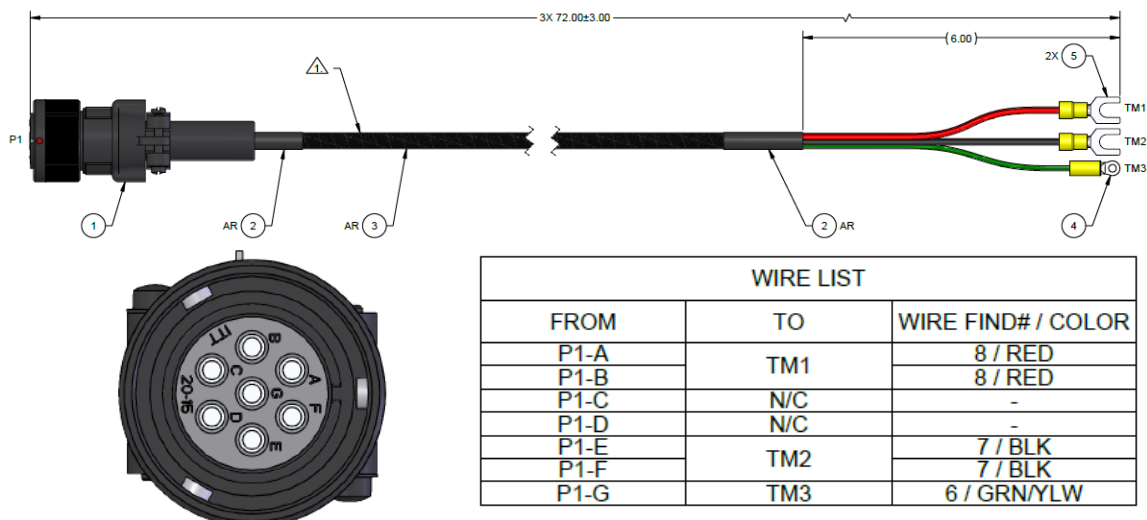

### 2.3.9 Monitor and Control Cable

Single unit mating connectors are provided.

**OPTIONAL:** As an alternate, the following cable can be purchased from Comtech EF Data, part number CA-0000445.

**Note:** Detailed cable drawings are included on the accompanying USB memory stick.

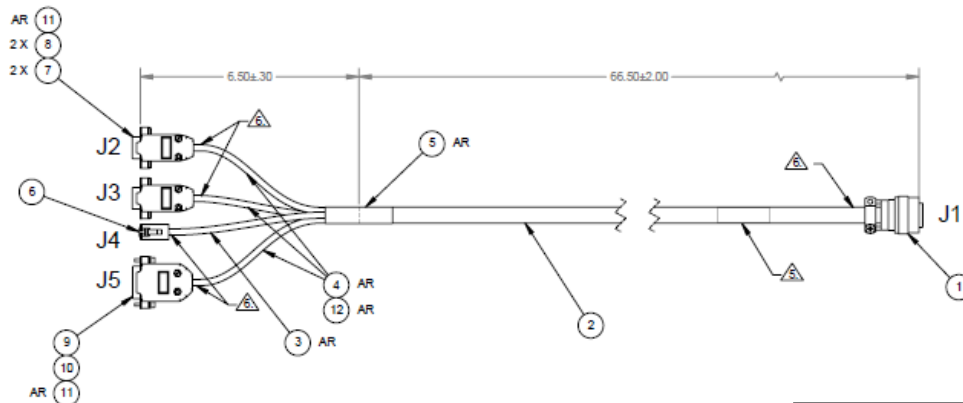

WIRE CHART	
FROM	TO
J2-PIN 1, J3-PIN 5, J5-PIN 9, 10, 11, 12, 13, 14, 15	J1 PIN K
J2 PIN 8	J1 PIN A
J2 PIN 4	J1 PIN C
J2 PIN 9	J1 PIN B
J2 PIN 5	J1 PIN D
J3 PIN 2	J1 PIN G
J3 PIN 3	J1 PIN E
J3 PIN 5	J1 PIN K

J4 PIN 1	J1 PIN F
J4 PIN 2	J1 PIN H
J4 PIN 3	J1 PIN V
J4 PIN 6	J1 PIN U
J5 PIN 1	J1 PIN L
J5 PIN 2	J1 PIN M
J5 PIN 3	J1 PIN N
J5 PIN 4	J1 PIN R
J5 PIN 5	J1 PIN S
J5 PIN 6	J1 PIN T

LABEL CHART	
CONNECTOR	LABEL NOMENCLATURE
J1	J1 Comm. Connector
J2	J2 RS-485 Serial Interface (ie: NI USB-485)
J3	J3 RS-232 Serial Interface (ie: NI USB-232)
J4	J4 MDI with auto crossover. Plug into ethernet router / NIC
J5	J5 Discrete I/O

2



**FOR SAFETY REASONS, NEVER TURN THE UNIT ON WITHOUT PROPER WAVEGUIDE TERMINATION ON THE 'J2 | RF OUT' PORT. YOU MAY OTHERWISE BE EXPOSED TO DANGEROUSLY HIGH ELECTROMAGNETIC LEVELS.**

The LGaN does not have a 'Power ON/OFF' switch. Power **ON** the unit by connecting the 'J3 | POWER IN' connector to the appropriate prime power source. The Mute or Transmit status of the SSPA automatically comes up in the last stored state (factory default = Transmit on, not muted).

BLANK PAGE

# Chapter 3. FIRMWARE UPDATE

---

## 3.1 Firmware Update Overview



*Make sure to operate the LGaN with its latest available firmware.*

CEFD's LGaN family of Outdoor Amplifiers / BUCs are factory-shipped with the latest version of operating firmware. If you need to update the firmware, you can apply the update to the LGaN without having to remove it from operation. You may directly acquire the download from CEFD's web site ([www.comtechefdata.com](http://www.comtechefdata.com)), or receive the archive file by e-mail from CEFD Product Support.

### 3.1.1 Important Considerations

Before you proceed with the firmware update, make sure that:

- The LGaN '**J6 | COM1**' receptacle is connected to the user personal computer (PC) using one of the methods described in Section 3.2.1.1.
- The PC is running a terminal emulation program for operation of the LGaN Serial or Ethernet Telnet interfaces.
- The LGaN Management IP Address has been noted.
- The PC is running a compatible Web browser for operation of the LGaN HTTP Interface.
- The CEFD's latest firmware files have been downloaded or are available on the User PC in an accessible temporary folder.

### 3.1.2 LGaN Firmware Update Procedure Summary

1. Download the firmware update archive file to a user-supplied PC. The user PC must be Microsoft Windows® compatible.
2. Use an adapter cable to directly connect the LGaN **J6 | COM1** receptacle to the serial port of the user PC.
3. Extract the firmware update files from the archive download file. The file to be uploaded is similar to FW-0021193-\_v1.1.1.zip.
4. Navigate to the **Admin > Upgrade** web page.
5. Follow the **Firmware Upgrade** procedure.

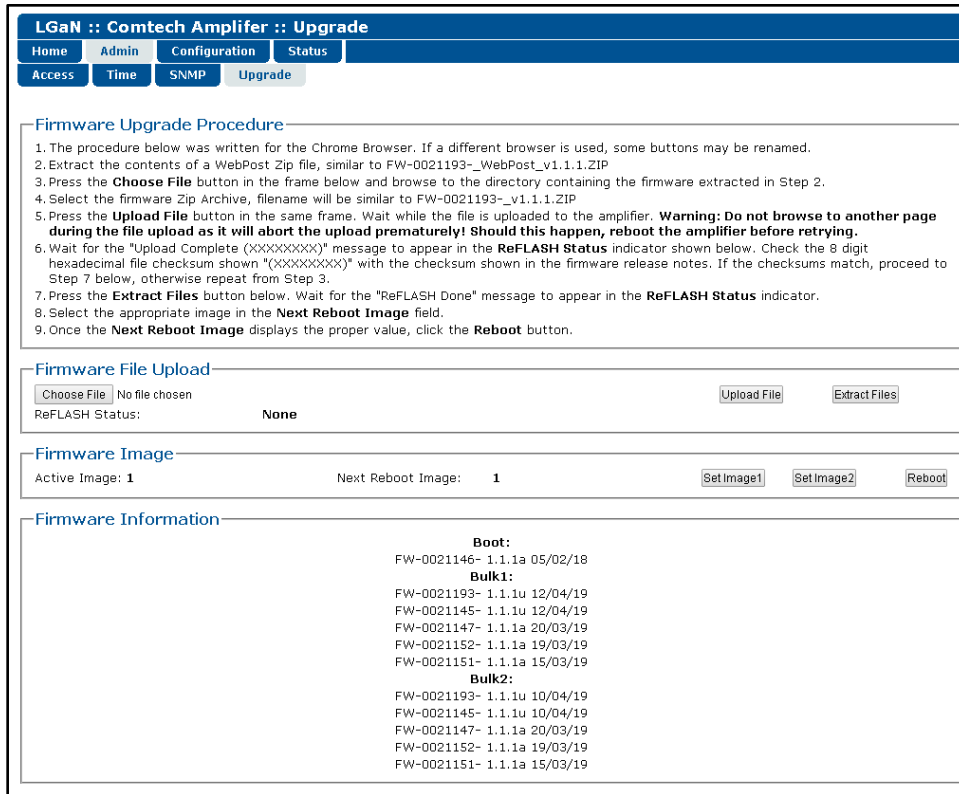

Figure 3-1. Upgrade Webpage Example

### 3.1.3 About Firmware Numbers, File Versions, and Formats

The CEFD website catalogues its firmware update files by product type (e.g., router, modem, etc.), the specific model, and optional hardware configurations. The Software Updates tab is displayed on the Home page. The Software Downloads page opens where there is another tab for Download Flash & Software Update Files. The LGaN is listed under Amplifiers. Once the LGaN page is opened, the LGaN firmware download hyperlink appears as FW-0021193X\_V###, where 'X' is the revision letter, and '###' represents the firmware version number (e.g., V156 = Version 1.5.6).

## 3.2 Prepare for the Firmware Download

### 3.2.1 Required User-supplied Items

You will need a Microsoft Windows-based PC equipped with available serial and Ethernet ports, a compatible Web browser (e.g., Internet Explorer), and a terminal emulator program (e.g., Tera Term or HyperTerminal).

### 3.2.1.1 LGaN Connections

For Ethernet connections, see Figure 3-2. Your connection may consist of the CAT5e Ethernet adapter cable (CEFD P/N CA-0000352) connecting the LGaN to the User PC Ethernet port. The example in Figure 3-2 uses the optional LGaNet (part of the CEFD KT-0000203 M&C Netbook Accessory Kit).

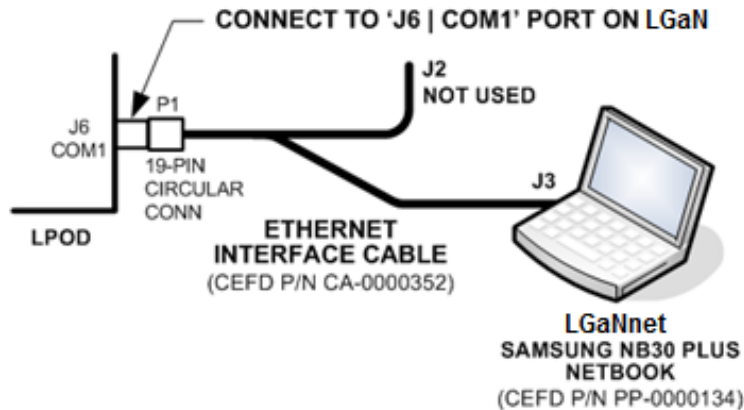

Figure 3-2. Standalone Ethernet Connection

### 3.2.2 LGaN Management IP Address and Firmware Information



#### Chapter 2. SYSTEM CONNECTORS, INSTALLATION, AND STARTUP

To obtain the LGaN Management IP Address and Firmware Information, do these steps:

1. On the LGaN, apply power to the unit. Refer to Chapter 2, **Section 2.2.3** or **2.2.4** to identify your specific power connector.
2. Identify your default Management IP Address. You will not be able to access the LGaN HTTP (Web Server) Interface without this information.
3. Get the firmware information using either of these methods:

To use the HTTP Interface, see **Section 3.2.2.1**.

#### 3.2.2.1 Locate Firmware Information via HTTP Interface



#### Chapter 4. ETHERNET INTERFACE OPERATION

To locate the Firmware information, use the HTTP Interface and do these steps:

1. Navigate to the **Admin > Upgrade** web page, as shown in Figure 3-2.
2. Write down your firmware information for further reference or to provide to CEFD Product support.

### 3.3 Download and Extract the Firmware Update Files

Do these steps:

1. Go to the CEFD website at [www.comtechefdata.com](http://www.comtechefdata.com).
2. On the Home page, click the **Software Updates** tab to open the Software Downloads page.
3. On the **Software Downloads** page, click **Download Flash and Software Update Files**.
4. Select the **Amplifiers** hyperlink.
5. Select the **LGaN** product hyperlink.
6. Select the appropriate firmware archive ZIP file download hyperlink.
7. Once you select the ZIP hyperlink, the **File Download** dialogue opens on your browser and prompts an action. You may otherwise click **[Cancel]** to quit the file download process. Note the following:
  - For ZIP files:

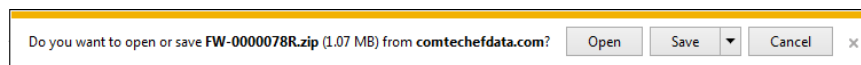

- Click **[Open]** to open the archive file. Use the WinZip features to select the files for extraction to your destination folder.
  - Click **[Save]** to download the ZIP file to your Windows Downloads folder. Once the download is complete the dialogue prompts you to either **[Open]** the archive file, or to open or view the Windows Downloads folder for further action.
8. If not already done with **File Download > Open**, you must extract, at a minimum, these files (filenames are subject to change):
  - FW-00201193X\_v111.zip – The Firmware Bulk Image file
  - FW-00201193X\_v111\_Release Notes.pdf – The Firmware Release Notes PDF file
  - The Webpost also contains \*.mib files, used for SNMP.



**WHERE: 'X' is the firmware revision letter, and '111' is the firmware version (e.g., FW Ver. 156 = "1.5.6")**

9. Confirm availability of the firmware files in a temporary folder. There are several ways you can view the contents of the temporary folder on a Windows-based PC:
  - To use the Windows Desktop, see **Section 3.2.2.1**.



# Chapter 4. ETHERNET INTERFACE OPERATION

---

## 4.1 Overview

Operation of the LGaN Ethernet Interface is available when you connect a user-supplied, windows-based PC to the 19-pin '**J6 | COM1**' communications port on the LGaN using the appropriate adapter cable.

Three protocols are available to use for Ethernet remote M&C. Operate these protocols separately.

- Simple Network Management Protocol (SNMP). This requires a user-supplied Network Monitoring System (NMS) and a user-supplied Management Information Base (MIB) File Browser.



**CEFD recommends use of the Ethernet-based SNMP interface for advanced users only. All other users are strongly encouraged to use the LGaN HTTP Interface for remote M&C of the LGaN.**

- Telnet Interface. You may use the serial remote control protocol via this interface. This requires use of Windows Command-line, or a user-supplied terminal emulation program such as Tera Term.
- HTTP (Web Server) Interface. This requires a compatible user-supplied web browser such as Google Chrome.

### 4.1.1 Prerequisites

Before you proceed with Ethernet remote product management, make sure the following is true:

- The LGaN is operating with the latest version firmware files.
- The User PC is running a terminal emulation program for operation of the LGaN Telnet Interface.
- The User PC is running a compatible web browser for operation of the LGaN HTTP Interface.
- The User PC is connected to the LGaN 19-pin '**J6 | COM1**' port. You may connect the User PC Ethernet port to the LGaN with the available CA-0000352 Ethernet Interface Cable (part of CEFD Kit KT-0000203).
- You have recorded the LGaN's Management IP Address.

---

## 4.2 SNMP Interface

SNMP is an Internet-standard protocol for managing devices over IP networks. An SNMP-managed network has three key components:

- The managed device. This includes the LGaN.
- The SNMP Agent. This software runs on the LGaN. The LGaN SNMP Agent supports both SNMPv1 and SNMPv2c.
- The user-supplied NMS. This software runs on the User PC.

### 4.2.1 Management Information Base (MIB) Files

An MIB file is used for SNMP remote management of a unique device, and consist of a tree of nodes called Object Identifiers (OIDs). Each OID provides remote management of a particular function. These MIB files should be compiled in a user-supplied MIB Browser or SNMP Network Monitoring System server.

In the LGaN MIB file names, the letter x represents the revision of the file.

---

#### 4.2.1.1 CEFD Root MIB File

- FW10874-2-.mib
- CEFD MIB file gives the root tree for all CEFD LGaN products (PSx) and consists of only the following OID:
  - Name: comtechEFData
  - Type: MODULE-IDENTITY
  - OID: 1.3.6.1.4.1.6247
  - Full path: iso(1).org(3).dod(6).internet(1).private(4).enterprises(1).comtechEFData(6247)  
Module: ComtechEFData

---

#### 4.2.1.2 LGaN MIB File

- FW-0021149X\_rev111.mib
- MIB file consists of all of the OID's for management of the LGaN functions.

---

#### 4.2.1.3 LGaN Traps MIB File

- FW-0021148X\_rev111.mib
- Trap MIB file provides SNMPv1 traps common for LGaN

## 4.2.2 SNMP Community Strings



**In SNMP v1/v2c, the SNMP Community String is sent unencrypted in the SNMP packets. Caution must be taken by the network administrator to ensure that SNMP packets travel only over a secure and private network if security is a concern.**

The LGaN uses Community Strings as a password scheme that provides authentication before gaining access to the router agent's MIBs. They are used to authenticate users and determine access privileges to the SNMP agent. The LGaN defines three Community Strings for SNMP access:

- Read Community            default = public
- Write Community         default = private
- Trap Community            default = comtech

Type the SNMP Community String into the user-supplied MIB Browser or Network Node Management software.



**For correct SNMP operation, the LGaN MIB files must be used with the associated version of the LGaN M&C. See the LGaN Firmware Release Notes for information on the required Firmware/Software (FW/SW) compatibility.**

## 4.2.3 SNMP Traps



**The LGaN SNMP agent supports both SNMPv1 and v2c. The LGaN Traps file needs to be compiled only if SNMPv1 traps are to be used.**

The LGaN has the ability to send out SNMP traps both when a fault occurs and when a fault clears in the unit. Configure which style of traps the LGaN sends by using the LGaN SNMP Trap Version OID.

The LGaN supports the following MIB2 SNMPv1 traps and v2 notifications:

MIB2 SNMPv1 trap: Authentication Failure	5
MIB2 SNMPv2 notifications: Authentication Failure	1.3.6.1.6.3.1.1.5.5

The LGaN supports the following Faults SNMPv1 traps and v2 notifications:

Faults SNMPv1 traps:	
LGaNPowerSupply24V1StatusV1	62474801
LGaNPowerSupply24V2StatusV1	62474802
LGaNPowerSupplyLNBSStatusV1	62474803
LGaNPowerSupply13VStatusV1	62474804
LGaNPowerSupply10VStatusV1	62474805
LGaNRFPowerSupply10V1StatusV1	62474806
LGaNRFPowerSupply10V2StatusV1	62474807
LGaNPowerSupply7V8TStatusV1	62474808
LGaNPowerSupply5V8TStatusV1	62474809

LGaNPowerSupply2V5TStatusV1	62474810
LGaNPowerSupply1V2TStatusV1	62474811
LGaNPowerSupplyNeg5V8TStatusV1	62474812
LGaNFan1StatusV1	62474813
LGaNFan2StatusV1	62474814
LGaNTemperatureStatusV1	62474815
LGaNShutdownStatusV1	62474816
LGaNi2CStatusV1	62474817
LGaNForwardPowerStatusV1	62474818
LGaNChecksumStatusV1	62474819
LGaNFPGADoneStatusV1	62474820
LGaNBUCLockDetectStatusV1	62474821
LGaNRefLockDetectStatusV1	62474822
LGaNLNBCSSStatusV1	62474823
LGaNSwitchStatusV1	62474824
<b>Faults SNMPv2 notifications:</b>	
LGaNPowerSupply24V1Status	1.3.6.1.4.1.6247.48.1.3.1.1
LGaNPowerSupply24V2Status	1.3.6.1.4.1.6247.48.1.3.1.2
LGaNPowerSupplyLNBSStatus	1.3.6.1.4.1.6247.48.1.3.1.3
LGaNPowerSupply13VStatus	1.3.6.1.4.1.6247.48.1.3.1.4
LGaNPowerSupply10VStatus	1.3.6.1.4.1.6247.48.1.3.1.5
LGaNRFPowerSupply10V1Status	1.3.6.1.4.1.6247.48.1.3.1.6
LGaNRFPowerSupply10V2Status	1.3.6.1.4.1.6247.48.1.3.1.7
LGaNPowerSupply7V8TStatus	1.3.6.1.4.1.6247.48.1.3.1.8
LGaNPowerSupply5V8TStatus	1.3.6.1.4.1.6247.48.1.3.1.9
LGaNPowerSupply2V5TStatus	1.3.6.1.4.1.6247.48.1.3.1.10
LGaNPowerSupply1V2TStatus	1.3.6.1.4.1.6247.48.1.3.1.11
LGaNPowerSupplyNeg5V8TStatus	1.3.6.1.4.1.6247.48.1.3.1.12
LGaNFan1Status	1.3.6.1.4.1.6247.48.1.3.1.13
LGaNFan2Status	1.3.6.1.4.1.6247.48.1.3.1.14
LGaNTemperatureStatus	1.3.6.1.4.1.6247.48.1.3.1.15
LGaNShutdownStatus	1.3.6.1.4.1.6247.48.1.3.1.16
LGaNi2CStatus	1.3.6.1.4.1.6247.48.1.3.1.17
LGaNForwardPowerStatus	1.3.6.1.4.1.6247.48.1.3.1.18

LGaNChecksumStatus	1.3.6.1.4.1.6247.48.1.3.1.19
LGaNFPGADoneStatus	1.3.6.1.4.1.6247.48.1.3.1.20
LGaNBUCLockDetectStatus	1.3.6.1.4.1.6247.48.1.3.1.21
LGaNRefLockDetectStatus	1.3.6.1.4.1.6247.48.1.3.1.22
LGaNLNBCSStatus	1.3.6.1.4.1.6247.48.1.3.1.23
LGaNSwitchStatus	1.3.6.1.4.1.6247.48.1.3.1.24

## 4.3 Telnet Interface



### Chapter 5. SERIAL INTERFACE OPERATION

The LGaN has a Telnet interface for the purpose of equipment M&C via the optional Serial Remote Control protocol. The Telnet interface requires user login at the **Administrator** level and **Read/Write** level. Once logged into the Telnet interface as the Administrator, you have access to the optional serial-based Remote Control Interface. An example of the login process and remote control operation is shown here:

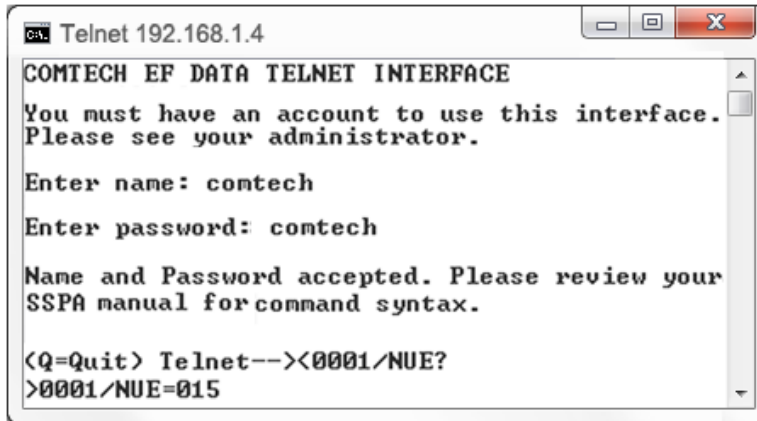

```
COMTECH EF DATA TELNET INTERFACE
You must have an account to use this interface.
Please see your administrator.

Enter name: comtech
Enter password: comtech

Name and Password accepted. Please review your
SSPA manual for command syntax.

<Q=Quit> Telnet--><0001/NUE?
>0001/NUE=015
```

Figure 4-1. Telnet Interface Example – Windows Command-line

### 4.3.1 Telnet Remote Control Operation via HyperTerminal

There is a disadvantage when using the Windows Command line as a Telnet client with the optional Remote Control protocol. For the messages coming from the Telnet Server, Command line cannot translate a carriage return command (**\r**) to a carriage return + line feed command (**\r\n**). Therefore, any multi-line Target-to-Controller response (e.g., the response to the FRW? query) shows as one line, with the latter lines overwriting the previous lines.

To see the full response messages, you can use the Tera Term terminal emulation program configured as a Telnet client. An example of the login process and remote control operation, when using Tera Term as the interface, is shown in Figure 4-2.

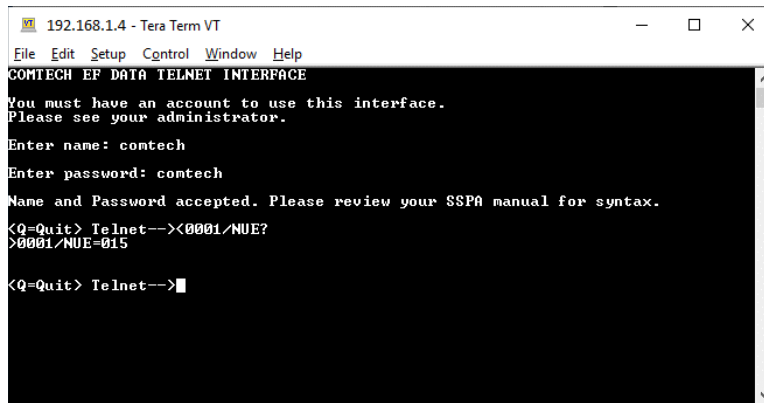

Figure 4-2. Telnet Interface Example – Tera Term

### 4.3.1.1 Configure Tera Term for Telnet Remote Control Operation

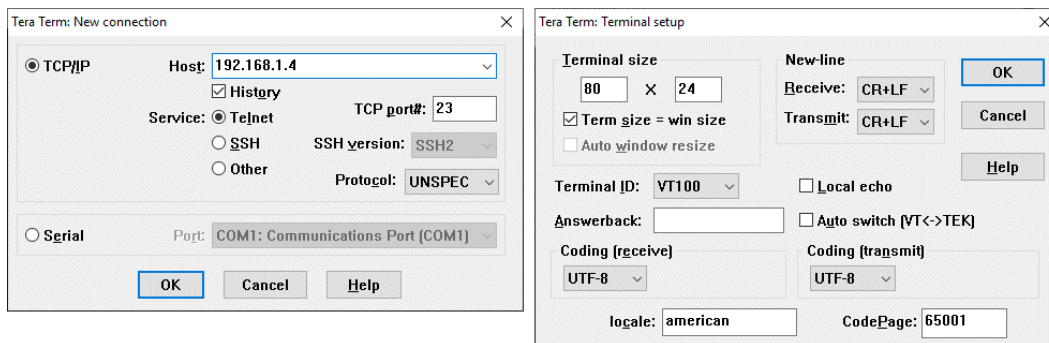

Figure 4-3. Configure Tera Term

See Figure 4-3. Do these steps:

1. Make sure to define the Connect To Telnet connection properties correctly (new connection prompt is displayed when Tera Term is started) (Figure 4-3):
  - a. Enter the LGaN's Traffic/Management IP Address as the "Host address" (e.g., 192.168.1.4).
  - b. Enter 23 as the "TCP port#".
  - c. Select TCP/IP instead of Serial.
  - d. Click **[OK]** to save your settings.
2. For Terminal Setup (Setup → Terminal) (Figure 4-3, right):
  - a. Select the "CR+LF" option in the Receive dropdown box in the New-line section.
  - b. Select the "CR+LF" option in the Transmit dropdown box in the New-line section.
  - c. Click **[OK]** to save your settings.

## 4.4 HTTP (Web Server) Interface



See Chapter 5. SERIAL INTERFACE OPERATION for more information about the LRS and IPA commands.

A user-supplied web browser allows the full M&C of the LGaN through its HTTP Interface. This embedded web application is designed for use with Microsoft's Internet Explorer Version 5.5 or higher. It is a non-secure web application.

### 4.4.1 Enable the HTTP Interface

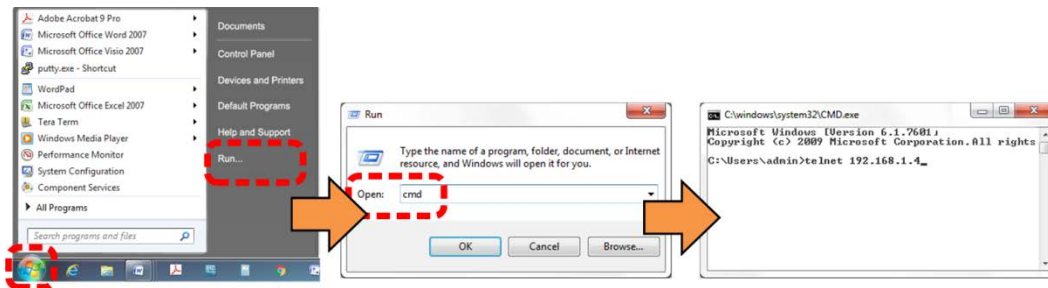

Figure 4-4. Open Windows Command-line

Follow these steps to enable the HTTP Interface in the LGaN using only a 100BaseTx remote interface (this assumes that you are running a Microsoft Windows operating system):

See Figure 4-4 and do these steps:

1. Select **Start**, then **Run**, then type "**cmd**" to open the Windows Command-line window.
2. Type "**Telnet 192.68.1.4**" to start a Telnet session with the unit using the default Management IP address.

See Figure 4-5 and do these steps:

3. Enter the Telnet username and password (the default for both parameters is **comtech**):
4. The Local Remote Status (LRS) remote command sets or returns Local or Remote state in the form x, where x=0, 1, 2, or 3:
  - LRS=0 (Local)
  - LRS=1 (Serial)
  - LRS=2 (Ethernet)
  - LRS=3 (Serial+Ethernet) (default value)

Use the **LRS=2** remote command to set the remote access parameter for Ethernet remote control.



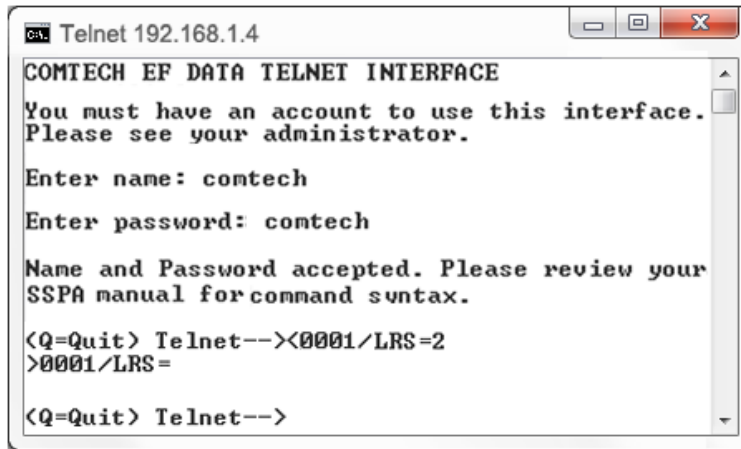

Figure 4-5. Telnet Login and Remote Command Execution



*You must assign a unique IP Address (IPA) for each unit on the network before connecting to an existing network. As the IP address may need to be changed to something other than the factory default setting, use the remote command **IPA=xxx.xxx.xxx.yy**, where: **xxx.xxx.xxx.xxx** is a valid IP address on the network where the unit is to be installed, and **yy** is the range (typically, **yy = 24**).*

*Changing the IPA value requires that you cycle power on the unit, and then start a new Telnet session using the new IP address.*

## 4.4.2 HTTP Interface User Login

Do these steps:

1. From the PC, enter the default Management IP Address for the LGaN (i.e., **http://192.168.1.4**) into the **Address** area of the browser.

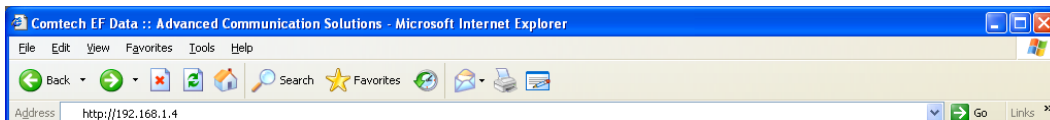

2. In the Login window, type the **User name** and **Password**, and then click **OK**. The default User Name and Password are both **comtech**.



Once the valid User Name and Password is accepted, the LGaN HTTP Interface splash page opens. The unit and firmware version in this example will differ from your setup.

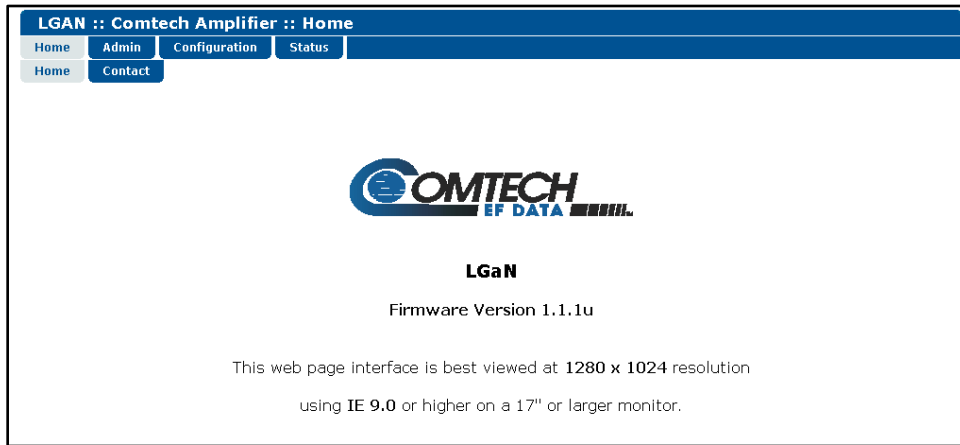

Figure 4-6. LGaN HTTP Interface 'Splash' Page Example

### 4.4.3 HTTP Interface Features

#### 4.4.3.1 Menu Tree

Home	Admin	Config	Status
Home	Access	Amplifier	Summary
Contact	Time	LNB	Status
Support	SNMP	Mask	FETs
	Update	Utility	Events
			MOP
			Statistics
			Trending Graphs

Figure 4-7. LGaN HTTP Interface Menu Tree

Figure 4-7 shows the menus and pages in the LGaN HTTP Interface. This interface has four top level navigation tabs, shown in blue. Each top level tab has page hyperlinks (grey). These hyperlinks open individual nested Web pages.

## 4.4.4 HTTPS Web Navigation

---

### 4.4.4.1 Page Navigation

The HTTP Interface has four navigation tabs at the top of each page. Click a navigation tab to see its page hyperlinks. Click a page hyperlink to open a page.



This manual uses a convention for all web pages to show you how to navigate to the featured page: Navigation Tab | Page Hyperlink. For example, “Home | Home” instructs you to click the ‘Home’ navigation tab, and then click the ‘Home’ page hyperlink.

### 4.4.4.2 Page Sections

This manual explains the purpose and operation for each Web page and its sections.

Each page has one or more sections. The title at the upper-left corner of each page or section describes its operational features. Each section can have editable fields, action buttons and read-only displays for a specific function.



### 4.4.4.3 Action Buttons

Action buttons are important in the LGaN HTTP Interface. Click an action button to do one of these tasks:

- Click **[Refresh]** to see the latest page data.
- Reset changed parameters to remove **unsaved** changes.
- **Submit** (save) changes.



*If you change any parameters, make sure to click the related action button before you leave the page. If you go to another page without first clicking the action button, your changes are not saved.*

### 4.4.4.4 Drop-down Lists

A drop-down list lets you choose from a list of selections. Left-click the drop-down button to open the list. Then, left-click on an item to select that choice.



### 4.4.4.5 Text or Data Entry

Text boxes let you type data into a field. An action button can be associated with a single text box, or a group of text boxes. For any text box, left-click anywhere inside the box and type the desired data into that field. Make sure to press **ENTER** when done typing.



Click the related action button to save the data.

## 4.5 HTTP Interface Pages

This section provides page examples and descriptions for the HTTP Interface.



### Chapter 5. SERIAL INTERFACE OPERATION



*The page figures provided in this section are intended for reference purposes only. Your setup may differ from what is shown in this section.*

### 4.5.1 Home Pages

Click **Home** or **Contact** to continue.

#### 4.5.1.1 Home | Home

Use this page to identify the product. Click the **Home** navigation tab or the page hyperlink to return to this page from anywhere in the HTTP Interface.

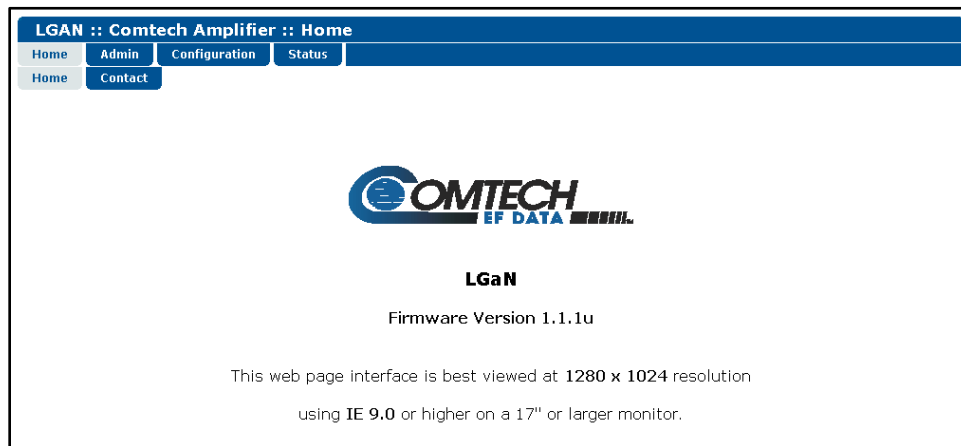

**Figure 4-8. LGaN 'Home | Home' Page (50 W Unit Example Shown)**

## 4.5.1.2 Home | Contact

For all product support, please call:

+1.240.243.1880

+1.866.472.3963 (toll free USA)

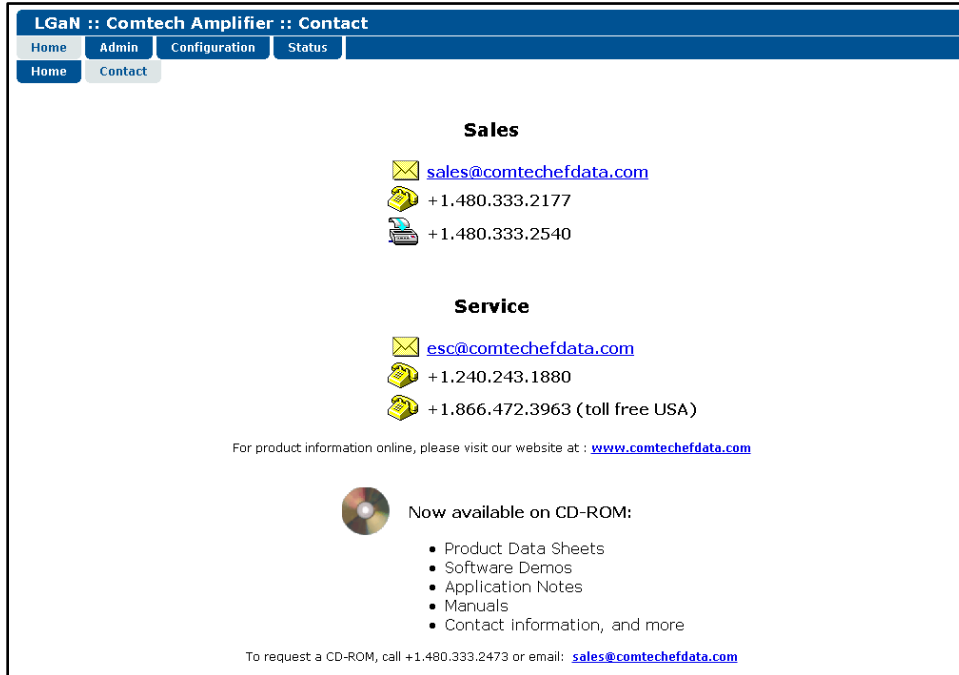

**LGaN :: Comtech Amplifier :: Contact**

Home Admin Configuration Status

Home Contact

**Sales**

✉ [sales@comtechedata.com](mailto:sales@comtechedata.com)

☎ +1.480.333.2177

☎ +1.480.333.2540

**Service**

✉ [esc@comtechedata.com](mailto:esc@comtechedata.com)

☎ +1.240.243.1880

☎ +1.866.472.3963 (toll free USA)

For product information online, please visit our website at : [www.comtechedata.com](http://www.comtechedata.com)

 Now available on CD-ROM:

- Product Data Sheets
- Software Demos
- Application Notes
- Manuals
- Contact information, and more

To request a CD-ROM, call +1.480.333.2473 or email: [sales@comtechedata.com](mailto:sales@comtechedata.com)

Figure 4-9. 'Home | Contact' Page

## 4.5.2 Admin (Administration) Pages



**These pages are available only to users who have logged in using the Administrator Name and Password.**

Use these administrator pages to set up user access. Click **Access**, **Time**, **SNMP**, or **Upgrade** to continue.

### 4.5.2.1 Admin | Access

Click **[Refresh]** to see the latest page data.

**Figure 4-10. 'Admin | Access' Page**

### Network Maintenance

Name	Description
IP Gateway	Enter the desired IP Gateway Address in the text box.
IP Address	Enter the desired IP Address/Range in the text box.
MAC Address (read only)	The MAC is set at the factory to a guaranteed unique address that you cannot modify.

Click **[Submit Admin]** to save any changes.

## System Account Access Information

**Name** fields can be any alphanumeric combination with a maximum length of 10 characters.

**Password** fields can be any alphanumeric combination with a maximum length of 10 characters.

Name	Description
Read Only Name	The factory default is: <b>monitor</b>
Read Only Password	The factory default is: <b>1234</b>
Read/Write Name	The factory default is: <b>opcenter</b>
Read/Write Password	The factory default is: <b>1234</b>
Admin Name	The factory default is: <b>comtech</b>
Admin Password	The factory default is: <b>comtech</b>
Session Timeout	Number of seconds to Session Timeout

Click [**Submit Admin**] to save any changes.

### 4.5.2.2 Admin | Time

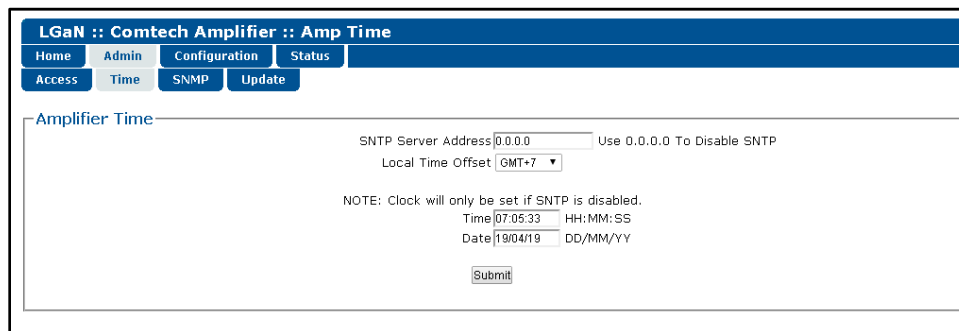

Figure 4-11. 'Admin | Access' Page

## Amplifier Time

Name	Description
SNTP Server Address	Enter the desired IP of the SNTP Server Address. (0.0.0.0 = SNTP is disabled)
Local Time Offset	Enter the GMT offset for the Amplifier Location (-12 to +12)
Time	Enter the Time
Date	Enter the Date

Click [**Submit**] to save any changes.

### 4.5.2.3 Admin | SNMP

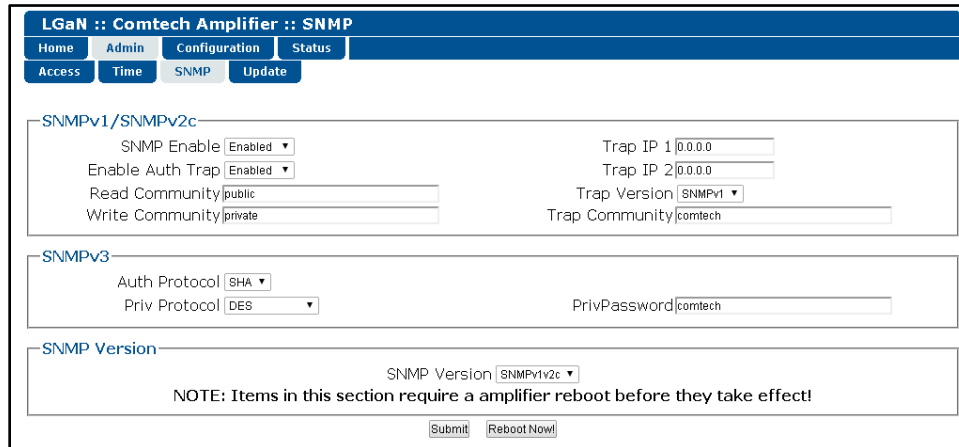

Figure 4-12. 'Admin | SNMP' Page

#### SNMPv1/SNMPv2c

Name	Description
Simple Network Management	Use the drop-down list to select <b>Enabled</b> or <b>Disabled</b> .
Read Community String	Automatically populates as <b>public</b> .
Write Community String	Automatically populates as <b>private</b> .
Enable Authentication Trap	Use the drop-down list to select <b>Enabled</b> or <b>Disabled</b> .
Trap IP 1	The Administrator can assign up to two <b>SNMP Trap IP Addresses</b> .
Trap IP 2	The Administrator can assign up to two <b>SNMP Trap IP Addresses</b> .
Trap Version	Use the drop-down list to select the version.
Trap Community String	This can be any combination of characters and a length of 0 to 20 characters. The factory default for the SNMP Trap Community String is "comtech".

#### SNMP Version

Name	Description
SNMP Version	Use the drop-down list to select SNMPv1v2c. A reboot is required for the selection to take affect.

Click **[Submit]** to save any changes.



## 4.5.2.4 Admin | Upgrade

LGaN :: Comtech Amplifier :: Upgrade
Home Admin Configuration Status

Access Time SNMP Upgrade

**Firmware Upgrade Procedure**

1. The procedure below was written for the Chrome Browser. If a different browser is used, some buttons may be renamed.
2. Extract the contents of a WebPost Zip file, similar to FW-0021193-WebPost\_v1.1.1.ZIP
3. Press the **Choose File** button in the frame below and browse to the directory containing the firmware extracted in Step 2.
4. Select the firmware Zip Archive, filename will be similar to FW-0021193- v1.1.1.ZIP
5. Press the **Upload File** button in the same frame. Wait while the file is uploaded to the amplifier. **Warning: Do not browse to another page during the file upload as it will abort the upload prematurely! Should this happen, reboot the amplifier before retrying.**
6. Wait for the "Upload Complete (XXXXXXXX)" message to appear in the **ReFLASH Status** indicator shown below. Check the 8 digit hexadecimal file checksum shown "(XXXXXXXX)" with the checksum shown in the firmware release notes. If the checksums match, proceed to Step 7 below, otherwise repeat from Step 3.
7. Press the **Extract Files** button below. Wait for the "ReFLASH Done" message to appear in the **ReFLASH Status** indicator.
8. Select the appropriate image in the **Next Reboot Image** field.
9. Once the **Next Reboot Image** displays the proper value, click the **Reboot** button.

**Firmware File Upload**

Choose File: FW-0021193- v111v.ZIP Upload File Extract Files

ReFLASH Status: None

**Firmware Image**

Active Image: 1 Next Reboot Image: 1 Set Image1 Set Image2 Reboot

**Firmware Information**

**Boot:**

FW-0021146- 1.1.1a 05/02/18

**Bulk1:**

FW-0021193- 1.1.1v 18/04/19  
FW-0021145- 1.1.1v 18/04/19  
FW-0021147- 1.1.1a 20/03/19  
FW-0021152- 1.1.1a 19/03/19  
FW-0021151- 1.1.1a 17/04/19

**Bulk2:**

FW-0021193- 1.1.1v 18/04/19  
FW-0021145- 1.1.1v 18/04/19  
FW-0021147- 1.1.1a 20/03/19  
FW-0021152- 1.1.1a 19/03/19  
FW-0021151- 1.1.1a 17/04/19

Figure 4-13. 'Admin | Upgrade' Page

### Firmware Upgrade Procedure

Follow the procedure to upgrade the Firmware.

### Firmware File Upload

Name	Description
Choose File Button	Used to navigate to the Firmware Zip File.
Upload File Button	Used to upload the Firmware Zip File.
Extract Files Button	Used to extract the Firmware File from the Zip File.

Click **[Submit]** to save any changes.

### Firmware Image

Name	Description
Active Image	Indicates which image is active.
Next Reboot Image	Indicates which image will be use to in a reboot (or power cycle).
Set Image 1 Button	Set the Next Reboot Image to 1.
Set Image 2 Button	Set the Next Reboot Image to 2.
Reboot Button	Used to reboot the Amplifier.

### 4.5.3 Config Pages

Use the **Configuration** pages to configure all operating parameters for the LGaN. Click **Amplifier**, **LNB**, **Redundancy**, **Mask**, or **Utility** to continue.

#### 4.5.3.1 Config | Amplifier

**Figure 4-14. 'Config | Amplifier' Page**

#### RF Module

Name	Description
Amplifier	Use the drop-down list to select <b>OFF</b> or <b>ON</b> .
Attenuation (dB)	Enter a valid attenuation level (00.00 to 20.00 dB) in 0.25 dB steps.
Attenuation Offset	Enter a valid offset value, in dB (00.00 to 20.00 dB) in 0.25 dB steps. Used for Redundancy's offline unit to match Tx Gain to the online unit. Displayed only when Redundancy is turned on.
Fault Recovery	Use the drop-down list to select <b>Automatic</b> or <b>Manual</b> .
Mute	Use the drop-down list to select <b>Enabled</b> or <b>Disabled</b> .
Aux Mute	Use the drop-down list to select <b>Enabled</b> or <b>Disabled</b> .
Offline Mute	Use the drop-down list to select <b>Enabled</b> , <b>Disabled</b> , <b>MuteRx</b> , <b>MuteTx</b> , <b>MuteRx+LNB</b> , <b>MuteTx+LNB</b> , <b>Mute Tx+Amp</b> , or <b>Mute Tx+LNB+Amp</b> . Displayed only when Redundancy is turned on.

Click [**Submit RF**] to save any changes.

## RF Power Threshold Settings

Name	Description
Max Forward Power	Set the threshold value for the Max Forward Power (dBm). Value of 00.00 disables this function.
Min Forward Power	Set the threshold value for the Min Forward Power (dBm). Value of 00.00 disables this function.
Max Reverse Power	Set the threshold value for the Max Reverse Power (dBm). Value of 00.00 disables this function. Not displayed if not equipped.
Min Input Power	Set the threshold value for the Min Input Power (dBm). Value of 00.00 disables this function. Not displayed if not equipped.

When the forward/Reverse/Input power monitor is set to **Alarm** or **Fault** instead of the factory default of **Mask**, and the forward power drops below the specified value, the alarm/fault occurs.

Click **[Submit Thres]** to save any changes.

## Reference

Name	Description
Ref Freq Adjust	Enter a valid reference oscillator tuning voltage value from <b>0</b> to <b>4095</b> . The default value is set to <b>640</b> . Displayed only when Internal Reference is equipped.
Ext Ref Mute	Use the drop-down list to select the External Reference Not Present Mute Mode as either <b>Enabled</b> or <b>Disabled</b> . Displayed only when Internal Reference is equipped.

Click **[Submit Ref]** to save any changes.

## Serial Communication Settings

Name	Description
Remote Address	Enter a valid physical remote address from <b>0001</b> to <b>9999</b> .
Baud Rate	Use the drop-down list to select the operating baud rate as <b>2400</b> , <b>4800</b> , <b>9600</b> , <b>19200</b> , or <b>38400</b> baud.

Click **[Submit Serial]** to save.

## FSK Address

Set the FSK (Frequency Shift Keying) Address from **01** to **15**. Used to control the Amplifier with the Comtech Modem's front panel.

Click **[Submit FSK]** to save any changes.

### 4.5.3.2 Config | LNB

Figure 4-15. 'Config | LNB' Page



***This webpage is only displayed when Internal Reference is active.***

### LNB Configuration

Name	Description
LNB Current Source	Use the drop-down list to select <b>Disable</b> or <b>18V, tone off, band 3</b> .   <b><i>These are the only valid selections when using LGaN LNB bias functionality with standard single-band LNBs.</i></b>
Switch Bias Tee	Use the drop-down list to select <b>Through State</b> (unmute LNB) or <b>Off State</b> (mute LNB).
LNB Current Window	Use the drop-down list to select this feature as either <b>Enabled</b> or <b>Disabled</b> .
LNB Current Window (%)	This field defines the size of the LNB Current Window, and determines the fault thresholds for the LNB current draw.  Any LNB current reading that is outside the window may generate an alarm, a fault, or may be masked entirely depending on the state of the user-configured fault mask (see the <b>MSK</b> command syntax in <b>Chapter 5. SERIAL INTERFACE OPERATION</b> for more information).  <b>For example:</b> If the LNB draws 100mA, and the LNB current fault window is set to the <b>default</b> value of <b>30(%)</b> , then the allowable current draw for the LNB will be from 70 mA minimum to 130 mA maximum because the window is $\pm 30\%$ centered on the calibrated LNB current draw.

Click **[Submit LNB]** to save.

### Calibrate LNB Current



***Calibrate the LNB only when it is running at nominal operating conditions.***

The value provided here (in mA) is intended as a reference point. The alarm upper and lower thresholds are determined by this value and the LNB current window setting.

Click **[Calibrate]** to perform an LNB calibration and display the updated **read-only** value.

### 4.5.3.3 Configuration | Mask

Some of the LGaN events can be user configured. The events can be Masked, Alarm or Fault via a drop-down box.

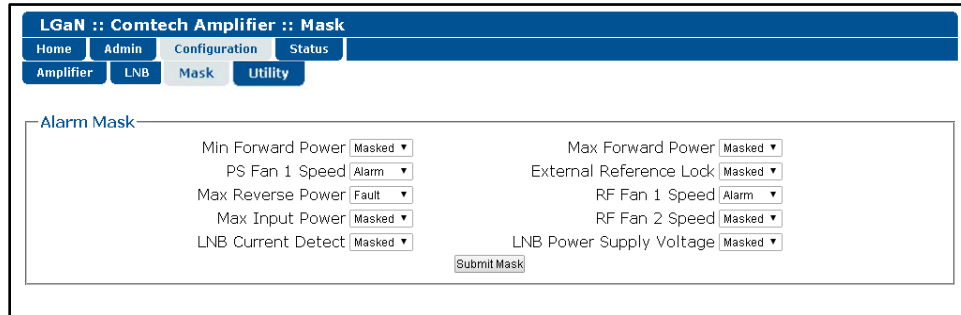

Figure 4-16. 'Configuration | Mask' Page

#### Alarm Mask

Name	Description
Min Forward Power	User sets the threshold (see Configuration   Amplifier)
Max Forward Power	User sets the threshold (see Configuration   Amplifier)
PS Fan 1 Speed	How to handle a Fan Event.
External Reference Lock	How to handle a External Reference Lock loss.
Max Reverse Power	User sets the threshold (see Configuration   Amplifier). Display only if equipped.
RF Fan 1 Speed	How to handle a Fan Event. Display only if equipped.
Max Input Power	User sets the threshold (see Configuration   Amplifier). Display only if equipped.
RF Fan 2 Speed	How to handle a Fan Event. Display only if equipped.
LNB Current Detect	How to handle a LNB Current event (see Configuration   Redundancy). Display only if equipped.
LNB Power Supply Voltage	How to handle a LNB Voltage event. Display only if equipped.

Click **[Submit Mask]** to save.

### 4.5.3.4 Config | Utility

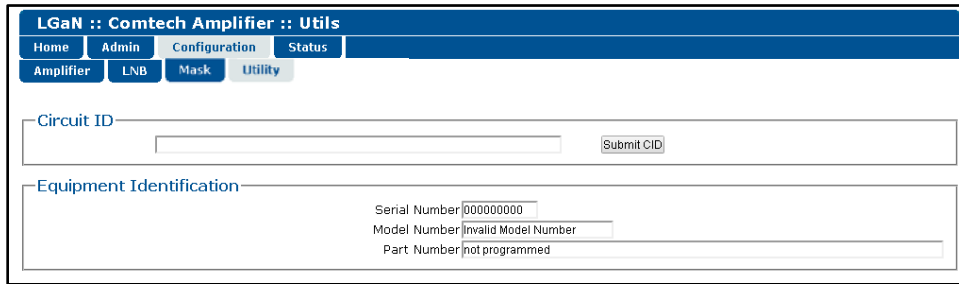

Figure 4-17. 'Configuration | Utility' Page

#### Circuit ID

Name	Description
Circuit ID	Enter a Circuit ID (unit identification label) string of up to 48 characters. This is the identification label for the unit. Click <b>Change CID</b> to save the change.

#### Equipment Identification

Name	Description
Serial Number	Read Only
Model Number	Read Only
Part Number	Read Only

## 4.5.4 Status Pages

Use these pages to access to event logging, operational statistics, status, FET windows, and operational trending graphs. Click the **Status** tab, and then click the **Summary**, **Status**, **FETs**, **Events**, **MOP**, **Statistics**, or **Trending** hyperlink to continue.

### 4.5.4.1 Status | Summary

Click **[Refresh]** to see the latest page data.

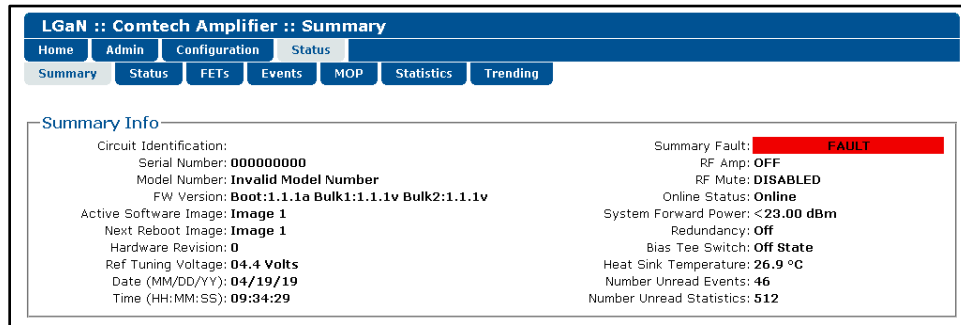

Figure 4-18. 'Status | Summary' Page

## Summary Info

Name	Description
Summary	The <b>Summary Fault</b> line indicates that no faults are present with "OK" on green background. If a fault exists, the <b>Summary Fault</b> message changes to "FAULT" on a red background. Should this occur, review the logged faults and alarms on the <b>Status   Events</b> page (see Sect. 4.5.4.4).
Terminal Status Change	This section alerts you to any configuration changes that were made to the unit since the last time the Terminal Status Change flag was reset (i.e., you click <b>[Clear]</b> to reset the message): <ul style="list-style-type: none"> <li>• If the status displays <b>NO</b>, no changes have been made to the unit.</li> <li>• If the status displays <b>YES</b>, then a status change has occurred for one or more of the following reasons: <ul style="list-style-type: none"> <li>○ An operating parameter is changed, e.g., when a command that changes an operational value is executed successfully;</li> <li>○ A fault condition is triggered;</li> <li>○ A redundant switchover occurs.</li> </ul> </li> </ul>

### 4.5.4.2 Status | Status

Use this read-only page see general status data for the LGaN.



**The Status / Status page updates automatically once every 5 seconds. Some fields will display, only if equipped (e.g. If the system doesn't have an Internal Reference and LNB attached to the Amplifier, then the LNB Current & LNB PS information is not displayed.)**

LGaN :: Comtech Amplifier :: Status			
<a href="#">Home</a> <a href="#">Admin</a> <a href="#">Configuration</a> <a href="#">Status</a>			
<a href="#">Summary</a> <a href="#">Status</a> <a href="#">FETs</a> <a href="#">Events</a> <a href="#">MOP</a> <a href="#">Statistics</a> <a href="#">Trending</a>			
<b>System</b>			
PARAMETER	MONITOR	STATUS	
Forward Power	<23.00 dBm	NA	
Reverse Power	<25.00 dBm	NA	
Input Power	+00.00 dBm	OK	
Internal Temperatures		OK	
RF Overdrive	00.00 dB	OK	
Outside Temperature	25.6 °C	OK	
Redundant Switch	NA	NA	
Redundant Link		NA	
LNB Current Draw	00.0 mA	NA	
LNB PS	00.0 V	NA	
Reference Lock Detect	NA	NA	
BUC Lock Detect		OK	
<b>RF MODULE</b>			
PARAMETER	MONITOR	STATUS	
Heat Sink Temperature	23.8 °C	OK	
Exhaust Temperature	0.0 °C	NA	
Fan 2 Speed	75 %	OK	
Fan 3 Speed	0 %	NA	
<b>PS MODULE</b>			
PARAMETER	MONITOR	STATUS	
24V Power Supply	23.9 Volts	OK	
24V Current	2.8 Amps	OK	
RF 40V Power Supply	0.0 Volts	NA	
RF 40V Current	0.0 Amps	NA	
RF 10V Power Supply	0.0 Volts	NA	
RF 10V Current	0.0 Amps	OK	
Vrms	205.8 Volts	OK	
Irms	1.3 Amps	NA	
Vpeak	298.0 Volts	NA	
Power	235.1 Watts	NA	
Power	258.0 VA	NA	
PF	0.9115	NA	
Line Frequency	60.0 Hz	OK	
13.5V Power Supply	13.6 Volts	OK	
5.8V Power Supply	5.9 Volts	OK	

Figure 4-19. 'Status | Status' Page



### 4.5.4.3 Status | FETs

Use this **read-only** page to monitor the current operating status of the LGaN's Qx RF Power Field Effect Transistors (FETs) that are installed in the RF amplifier.



*Each LGaN product type will have a different number of FETs: Q1-Qx*

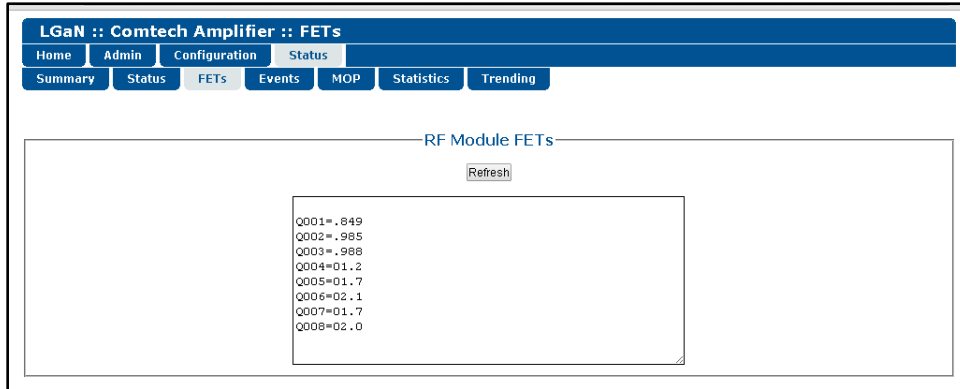

**Figure 4-20. 'Status | FETs' Page**

### 4.5.4.4 Status | Events

Use this page to see stored events data. The whole Event log is displayed.

Click **[Refresh]** to see the latest page data.

LGaN :: Comtech Amplifier :: Events													
Home		Admin		Configuration		Status							
Summary		Status		FETs		Events		MOP		Statistics		Trending	
Events Log													
<input type="button" value="Refresh"/>				<input type="button" value="Clear Log"/>									
	Date	Time	Type										
1	04-18-19	09:43:40	Info - LOG Faults Cleared										
2	04-18-19	09:43:46	Alarm - PS Vrms 170										
3	04-18-19	09:43:52	Okay - PS Vrms										
4	04-18-19	09:44:41	Alarm - PS Line FRQ 42										
5	04-18-19	09:44:52	Okay - PS Line FRQ										
6	04-18-19	09:45:12	Alarm - PS Line FRQ 65										
7	04-18-19	09:45:22	Okay - PS Line FRQ										
8	04-18-19	09:48:04	Info - LOG Unit Power Off										
9	04-18-19	09:50:33	Info - LOG Unit Power On										
10	04-18-19	09:51:12	Info - LOG Unit Power Off										
11	04-18-19	09:51:44	Info - LOG Unit Power On										
12	04-18-19	09:52:56	Info - LOG Unit Power Off										
13	04-18-19	09:53:17	Info - LOG Unit Power On										
14	04-18-19	10:02:56	Info - LOG Unit Power Off										
15	04-18-19	10:07:57	Info - LOG Unit Power On										
16	04-18-19	10:07:59	Info - LOG Unit Power Off										
17	04-18-19	10:18:58	Info - LOG Unit Power On										
18	04-18-19	10:20:27	Alarm - PS 24V PS Current										
19	04-18-19	10:21:45	Info - LOG Unit Power Off										
20	04-18-19	10:22:14	Info - LOG Unit Power On										
21	04-18-19	10:28:32	Okay - PS 24V PS Current										
22	04-18-19	10:31:10	Fault - PS 24V RF Current										
23	04-18-19	10:33:54	Info - LOG Unit Power Off										
24	04-18-19	13:31:43	Info - LOG Unit Power On										
25	04-18-19	13:32:53	Fault - PS 24V PS Current										
26	04-18-19	13:33:46	Fault - PS 24V RF Current										
27	04-18-19	13:34:55	Alarm - PS 24V PS Current										
28	04-18-19	13:34:55	Okay - PS 24V PS Current										
29	04-18-19	13:37:35	Alarm - PS 24V RF Current										
30	04-18-19	13:37:35	Okay - PS 24V RF Current										
31	04-18-19	13:39:15	Fault - PS 24V RF Current										
32	04-18-19	13:39:50	Info - LOG Unit Power Off										
33	04-18-19	15:33:23	Info - LOG Unit Power On										
34	04-18-19	15:33:58	Info - LOG Unit Power Off										
35	04-18-19	15:34:43	Info - LOG Unit Power On										
36	04-18-19	16:07:53	Alarm - PS PS Fan1										
37	04-18-19	16:07:53	Okay - PS PS Fan1										
38	04-18-19	16:25:32	Info - LOG Unit Power Off										
39	04-19-19	07:04:53	Info - LOG Unit Power On										
40	04-19-19	07:57:34	Info - LOG Unit Power Off										

Figure 4-21. 'Status | Events' Page

### 4.5.4.5 Status | MOP

This page shows the Maximum Operating Points (MOPs). Maximum and some Minimum values of critical monitored parameters.

Click **[Refresh]** to see the latest page data.

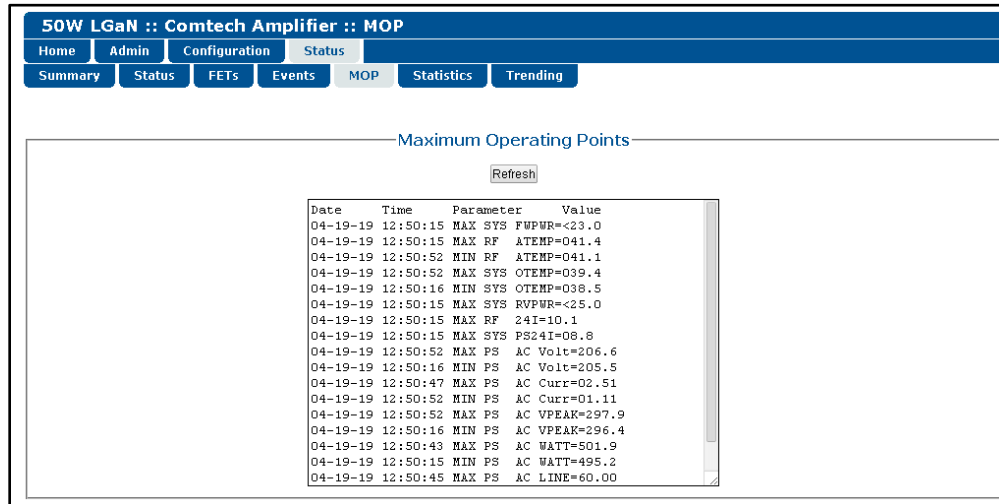
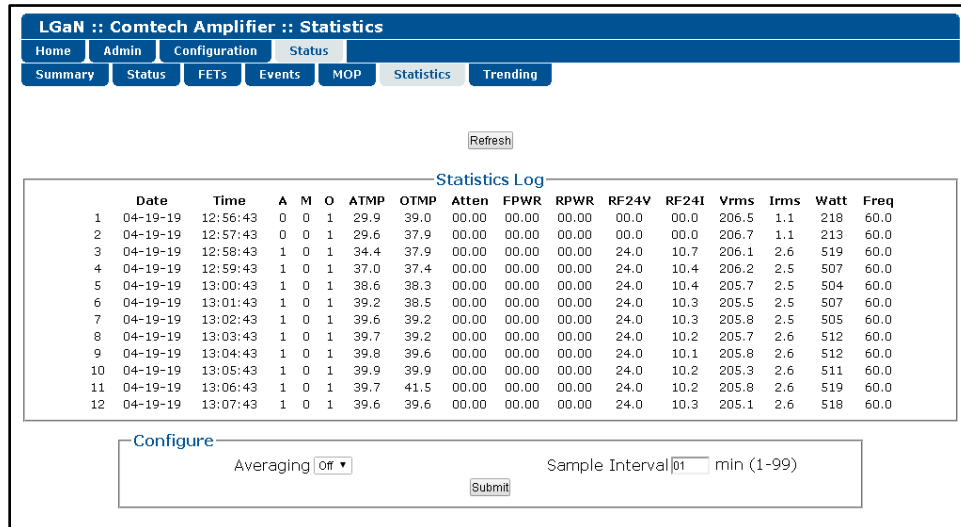

Figure 4-22. 'Status | MOP' Page

### 4.5.4.6 Status | Statistics

This page shows stored statistics. Use it to configure how the LGaN handles and shows statistics.

Click **[Refresh]** to see the latest page data.



**LGaN :: Comtech Amplifier :: Statistics**

Home Admin Configuration **Status**

Summary Status FETs Events MOP **Statistics** Trending

Refresh

Statistics Log

	Date	Time	A	M	O	ATMP	OTMP	Atten	FPWR	RPWR	RF24V	RF24I	Vrms	Irms	Watt	Freq
1	04-19-19	12:56:43	0	0	1	29.9	39.0	00.00	00.00	00.00	00.0	00.0	206.5	1.1	218	60.0
2	04-19-19	12:57:43	0	0	1	29.6	37.9	00.00	00.00	00.00	00.0	00.0	206.7	1.1	213	60.0
3	04-19-19	12:58:43	1	0	1	34.4	37.9	00.00	00.00	00.00	24.0	10.7	206.1	2.6	519	60.0
4	04-19-19	12:59:43	1	0	1	37.0	37.4	00.00	00.00	00.00	24.0	10.4	206.2	2.5	507	60.0
5	04-19-19	13:00:43	1	0	1	38.6	38.3	00.00	00.00	00.00	24.0	10.4	205.7	2.5	504	60.0
6	04-19-19	13:01:43	1	0	1	39.2	38.5	00.00	00.00	00.00	24.0	10.3	205.5	2.5	507	60.0
7	04-19-19	13:02:43	1	0	1	39.6	39.2	00.00	00.00	00.00	24.0	10.3	205.8	2.5	505	60.0
8	04-19-19	13:03:43	1	0	1	39.7	39.2	00.00	00.00	00.00	24.0	10.2	205.7	2.6	512	60.0
9	04-19-19	13:04:43	1	0	1	39.8	39.6	00.00	00.00	00.00	24.0	10.1	205.8	2.6	512	60.0
10	04-19-19	13:05:43	1	0	1	39.9	39.9	00.00	00.00	00.00	24.0	10.2	205.3	2.6	511	60.0
11	04-19-19	13:06:43	1	0	1	39.7	41.5	00.00	00.00	00.00	24.0	10.2	205.8	2.6	519	60.0
12	04-19-19	13:07:43	1	0	1	39.6	39.6	00.00	00.00	00.00	24.0	10.3	205.1	2.6	518	60.0

Configure

Averaging  Sample Interval  min (1-99)

Figure 4-23. 'Status | Statistics' Page

### Configure

Name	Description
Statistics Interval	Enter the interval at which statistics are logged. The interval is set in minutes. Minimum resolution is 1 minute (001); maximum is 99 minutes (099). Default is 60 minutes (060).
Statistics Averaging	Select <b>Enable</b> or <b>Disable</b> to set the <b>Statistics Averaging</b> function: <ul style="list-style-type: none"> <li>If <b>Enabled</b>, statistics data is averaged at a rate of once per second for 10 seconds.</li> <li>If <b>Disabled</b>, burst values are logged instead of averaged values.</li> </ul> Click <b>Submit</b> to save the changes.

### 4.5.4.7 Status | Trending

Click [Refresh] to see the latest graph data.

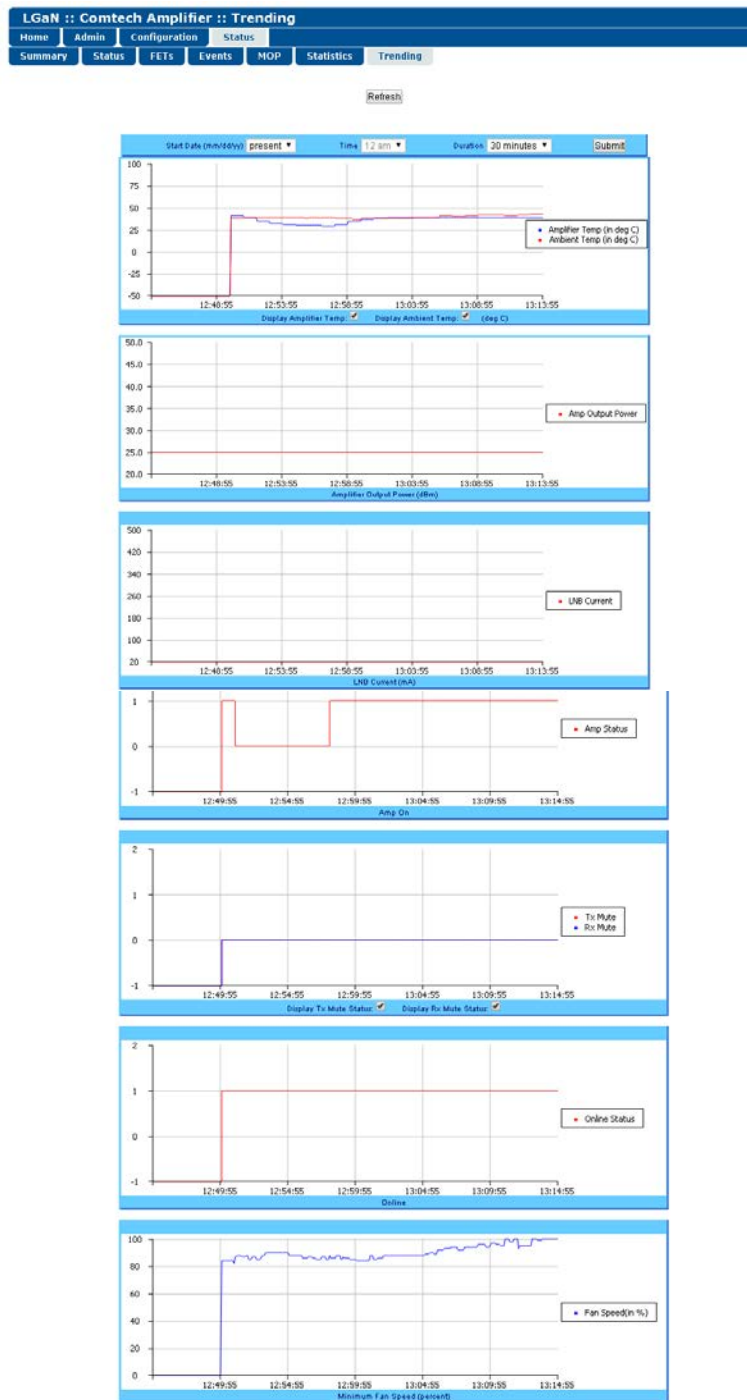



Figure 4-24. 'Status | Trending Graphs' Page

This scrolling page provides graphs that show trends over time for the following operating parameters:

- Amplifier Temperature
- Amplifier Output Power
- LNB Current
- Operating Status
- Rx Mute Status
- Online Status
- Minimum Fan Speed

## Trending Graph Time Settings

Choose the time, date, and duration of the trending information displayed on the graphs.

- **Start Date (mm/dd/yy):** Once a unit has been in operation for 24 hours or more, use the drop-down list to select a date – up to a maximum of 28 days, including the present date – from which to compile data. If a unit has *not* been in operation for 24 hours, only **present** will be available.
- **Time:** Once a unit has been in operation for 24 hours or more, use this drop-down list to select the time on the hour – 24 hours, from **12 am** to **11 pm**, are available. Note that, for the first 24 hours of operation (or beyond if the time has accrued), if you select **present** as the **Start Date**, then the **Time** drop-down list becomes unavailable for selection and dims as shown here.
- **Duration:** Use the drop-down list to select the block of time in which data is compiled for the graphs. Select **30 minutes**, **1 hour**, **2 hours**, **4 hours**, **6 hours**, **8 hours**, **12 hours**, **24 hours**, or **48 hours**.



***The LGaN stores the trending data to flash memory once per hour. If you power down the unit before the data can be written to memory, the last 60 minutes of data will be lost.***

Click [**Submit**] to execute your settings choices.

## Graphs

The graphs are all tied to the same 'x' scale so that you can more easily correlate data between the graphs.

### Temperature Graph

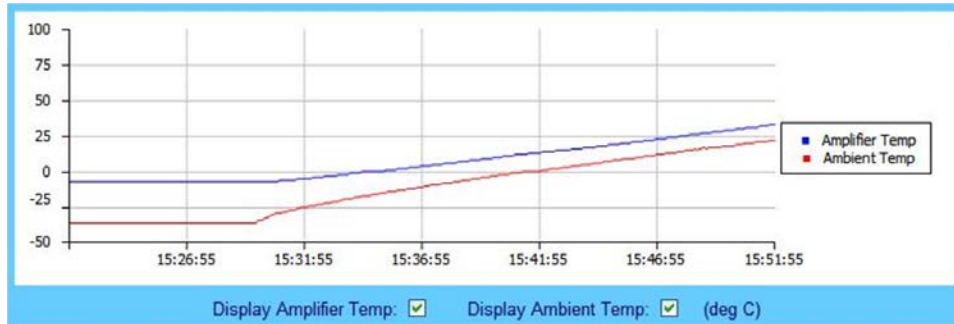

As per the legend:

- The blue line graphs the unit's Amplifier (heat sink) temperature
- When you install the available sensor in the unit, the red line graphs the Ambient (outdoor) temperature.

Check or uncheck a checkbox to control the graphing of either temperature. The graph will update dynamically after the next polling cycle (every five seconds).

### Power Graph



This graph displays the unit's output power with 1 dB resolution. You may set this information to display as **dBm**. The graph will update dynamically after the next polling cycle (every five seconds).



**When you click the [Refresh] tab, the graph reverts to the default display (Unit in dBm).**

### LNB Current Graph

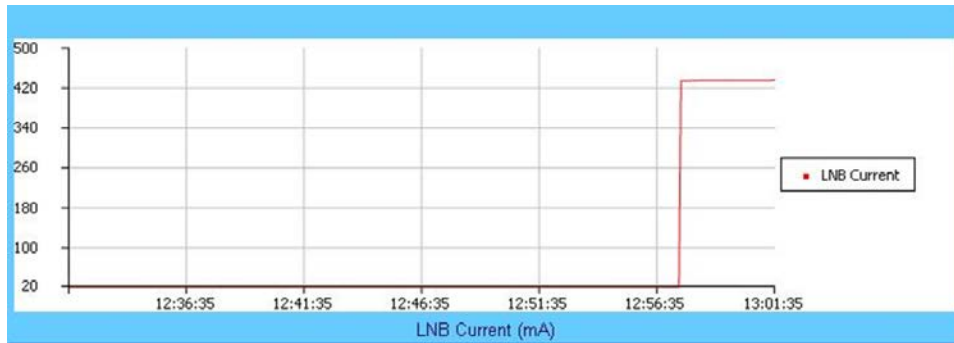

This graph displays the LNB current only if an LNB is connected to the system and is drawing current from the LNB current source.

### Amplifier Status Graph

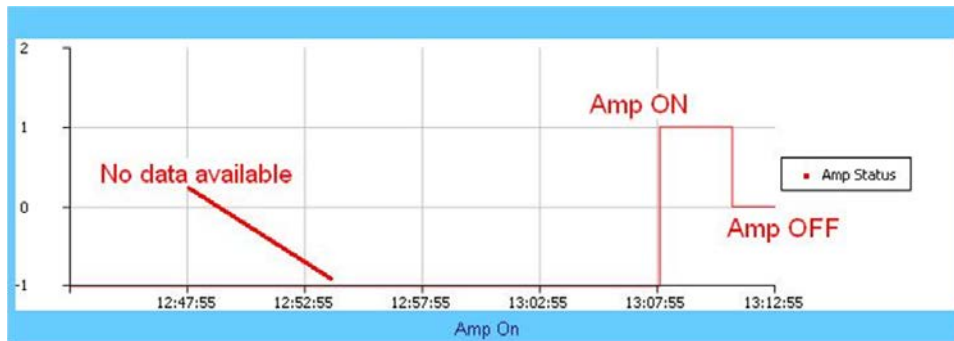

This graph displays the state of the RF amplifier (**On/Off**). As per this example:

- **On** is represented by a **1** (one)
- **Off** is represented by a **0** (zero)
- If no data is available, then the graph displays **-1** (negative one)



### Mute State Graph

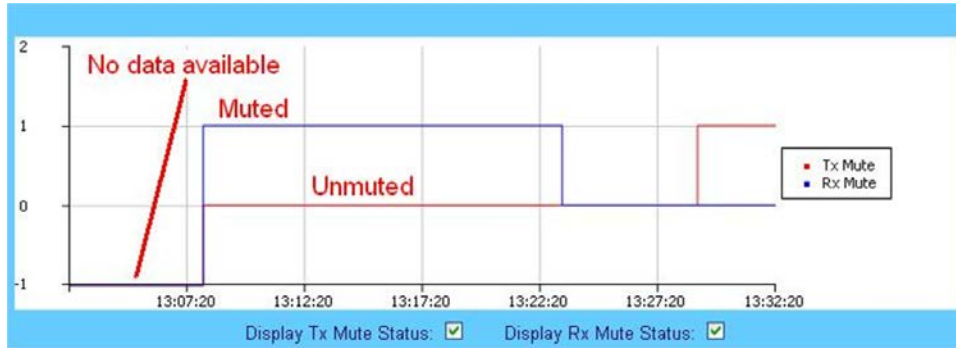

This graph displays the mute state (i.e., bias tee switch state as open = *muted*, or through path = *unmuted*) for the Tx Mute (red line) and the Rx Mute (blue line). Note that:

- A logic high on the graph equals a *muted* condition;
- A logic at **0** (zero) indicates an *unmuted* condition;
- A logic at **-1** (negative one) displays when data is *unavailable*.

Check or uncheck a checkbox to control the graphing of either muting function. The graph will update dynamically after the next polling cycle (every five seconds).

### Online Status Graph

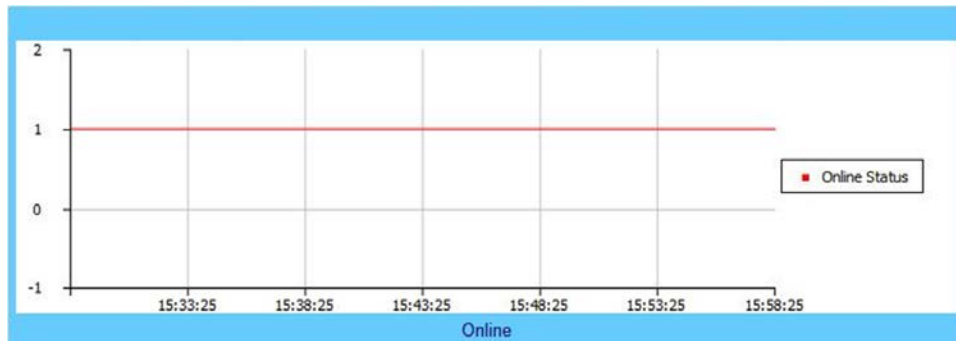

This graph displays the unit's online state. Note that:

- A logic of **1** (one) indicates the unit is *online*
- A logic of **0** (zero) indicates the unit is *offline*
- A logic of **-1** (negative one) displays when data is *unavailable*

### Minimum Fan Speed Graph

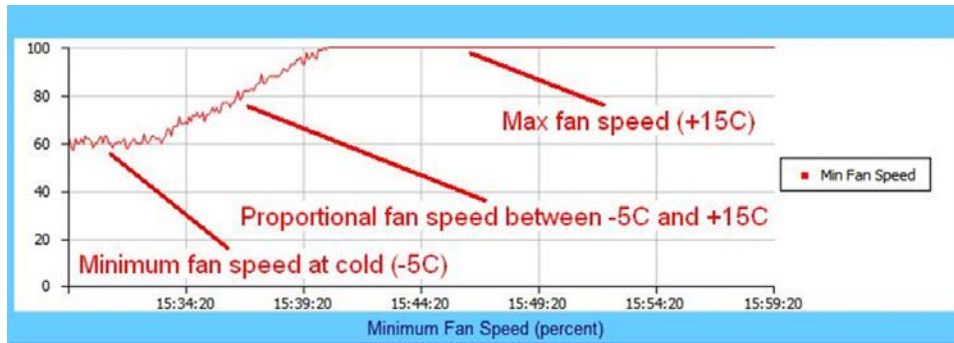

This graph displays the slowest fan speed of any of the fans installed in the system. This example demonstrates the fan running at minimum, proportional, and maximum speeds. Note that:

- Proportional fan speed: Proportional to the unit's heat sink temperature -5 to +15°C (23 to 59°F).
- Minimum fan speed: Temperatures at or below -5°C (23°F), the LGaN minimizes its fan speed.
- Maximum fan speed: Temperatures at or above +15°C (59°F), the LGaN maximizes its fan speed.

# Chapter 5. SERIAL INTERFACE OPERATION



*To achieve optimal performance and to access the most current remote control commands and queries, make sure to operate the LGaN with its latest available firmware.*

---

## 5.1 Overview

Serial-based remote management of CEFD's LGaN family of Outdoor Amplifiers / Block Up Converters (BUCs) is available using the 'J6 | COM1' port. This chapter summarizes key parameters and procedures and their associated remote commands and queries, and provides detailed instructions for use of the optional serial remote control commands and queries interface.

---

## 5.2 Key Operational Parameters / Common Commands and Queries

### 5.2.1 Faults

The M&C system monitors certain key functions for proper operation. Should any of these parameters exceed predetermined limits, the M&C system will declare a fault. The conditions that trigger a fault are:

- Any power supply outside its nominal value window
- A fan running at less than 25% of maximum speed
- Thermal Shutdown - A temperature fault is indicated if the unit is  $> +95^{\circ}\text{C}$  ( $203^{\circ}\text{F}$ ). This creates a summary fault and will cause the unit to mute itself and switch to the back-up unit (if in a redundant system). However, the 10V supply to the FET transistors will remain on until the unit reaches the thermal shutdown temperature of  $> 100^{\circ}\text{C}$  ( $212^{\circ}\text{F}$ ). For protection reasons, the unit will shut down the 10V supply to the power transistors at temperatures  $> 100^{\circ}\text{C}$  ( $212^{\circ}\text{F}$ ).

### 5.2.2 Common Commands

A few of the most common commands and queries are listed below. Full details for each of these are listed at the end of this section.

- RMS = Retrieve Maintenance Status. Displays voltages, fan speeds, Heatsink temperature, output power monitor reading, etc.
- RCS = Retrieve Configuration Status. Displays current attenuation, mute, amplifier, online, etc. status.
- RAS = Retrieve Alarm Status. Displays current alarm or fault status.

## 5.3 Remote Control Protocol and Structure

This section describes the protocol and message command set for remote monitor and control of the L GaN product.

For legacy serial communication the electrical interface is either a full duplex EIA-485/EIA-422 multi-drop bus (for the control of many devices) or an EIA-232 connection (for the control of a single device), and data is transmitted in asynchronous serial form, using ASCII characters. Control and status information is transmitted in packets of variable length in accordance with the structure and protocol defined in later sections.

Additionally, the L GaN product also supports the serial command protocol over a Telnet session through the use of a 10/100Base-T ethernet connection to the product. The ethernet communications interface also supports SNMP protocol, and provides a graphical user interface (GUI) through web pages that can be accessed using a web browser.

### 5.3.1 EIA-232

This is a much simpler configuration in which the controller device is connected directly to the target via a two-wire-plus-ground connection. Controller-to-target data is carried, via EIA-232 electrical levels on one conductor, and target-to-controller data is carried in the other direction on the other conductor.

### 5.3.2 EIA-485

For applications where multiple devices are to be monitored and controlled, a full-duplex (4-wire) EIA-485 is preferred. Half-duplex (2-wire) EIA-485 is possible, but is not preferred.

In full-duplex EIA-485 communication there are two separate, isolated, independent, differential-mode twisted pairs, each handling serial data in different directions. It is assumed that there is a 'controller' device (a PC or dumb terminal), which transmits data, in a broadcast mode, via one of the pairs. Many 'target' devices are connected to this pair, which all simultaneously receive data from the controller. The controller is the only device with a line-driver connected to this pair; the target devices only have line-receivers connected.

In the other direction, on the other pair, each target has a tri-stateable line driver connected, and the controller has a line-receiver connected. All the line drivers are held in high-impedance mode until one (and only one) target transmits back to the controller.

Each target has a unique address, and each time the controller transmits, in a framed 'packet' of data, the address of the intended recipient target is included. All of the targets receive the packet, but only one (the intended) will reply. The target enables its output line driver, and transmits its return data packet back to the controller in the other direction on the physically separate pair.

### 5.3.3 EIA-485 (Full Duplex)

Two differential pairs - one pair for controller to target, one pair for target to controller.

- Controller-to-target pair - has one line driver (controller), and all targets have line-receivers.
- Target-to-controller pair - has one line receiver (controller), and all targets have tri-state drivers.

### 5.3.4 EIA-232

This is a much simpler configuration in which the controller device is connected directly to the target via a two-wire-plus-ground connection. Controller-to-target data is carried, via EIA-232 electrical levels on one conductor, and target-to-controller data is carried in the other direction on the other conductor.

### 5.3.5 Basic Protocol

Whether in EIA-232 or EIA-485 mode, all data is transmitted as asynchronous serial characters, suitable for transmission and reception by a UART. The asynchronous character format is fixed at 8N1 (8 data bits, No parity, and 1 stop bit). Baud rates 2400, 4800, 9600, 19200, and 38400 are supported.

All data is transmitted in framed packets. The host controller is assumed to be a PC or ASCII dumb terminal, which is in charge of the process of monitor and control. The controller is the only device that is permitted to initiate, at will, the transmission of data. Targets are only permitted to transmit when they have been specifically instructed to do so by the controller.

All bytes within a packet are printable ASCII characters, less than ASCII code 127. In this context, the Carriage Return and Line Feed characters are considered printable.

All messages from controller to target require a response (with one exception). This will be either to return data that has been requested by the controller, or to acknowledge reception of an instruction to change the configuration of the target. The exception to this is when the controller broadcasts a message (such as Set Time/Date) using Address 0, when the target is set to EIA-485 mode.

## 5.4 Packet Structure

The exchange of information is transmitted, Controller-to-Target and Target-to-Controller, in '**packets**'. Each packet contains a finite number of bytes consisting of printable ASCII characters, excluding ASCII code 127.

In this context, the Carriage Return and Line Feed characters are considered printable. With one exception, all messages from Controller-to-Target require a response – this will be either to return data that has been requested by the Controller, or to acknowledge reception of an instruction to change the configuration of the Target.

Controller-to-Target						
Start of Packet	Target Address	Address Delimiter	Instruction Code	Code Qualifier	Optional Arguments	End of Packet
< ASCII code 60 (1 character)	(4 characters)	/ ASCII code 47 (1 character)	(3 characters)	= or ? ASCII codes 61 or 63 (1 character)	(n characters)	Carriage Return ASCII code 13 (1 character)

**EXAMPLE:** <0412/MUT=1{CR}

Target-to-Controller						
Start of Packet	Target Address	Address Delimiter	Instruction Code	Code Qualifier	Optional Arguments	End of Packet
> ASCII code 62 (1 character)	(4 characters)	/ ASCII code 47 (1 character)	(3 characters)	=, ?, !, or * ASCII codes 61, 63, 33, or 42 (1 character)	(From 0 thru n characters)	Carriage Return, Line Feed ASCII codes 13,10 (2 characters)

**EXAMPLE:** >0412/MUT=1{CR}{LF}

### 5.4.1 Start of Packet

The '<' and '>' characters indicate the start of packet. They may not appear anywhere else within the body of the message.

- Controller to Target: This is the character '<' (ASCII code 60)
- Target to Controller: This is the character '>' (ASCII code 62)

### 5.4.2 Address

Up to 9,999 devices can be uniquely addressed. In both EIA-232 and EIA-485 applications, the permissible range of values is 1 to 9999. It is programmed into a target unit using the remote control port.



*The controller sends a packet with the address of a target - the destination of the packet. When the target responds, the address used is the same address, to indicate to the controller the source of the packet. The controller does not have its own address.*

### 5.4.3 Address Delimiter

This is the forward slash character: / (ASCII code 47)

### 5.4.4 Instruction Code

This is a three-character alphabetic sequence that identifies the subject of the message. Wherever possible, the instruction codes have been chosen to have some significance – e.g., **AMP** for RF Power Amplifier State, **ATT** for attenuation, etc. This aids in the readability of the message, should it be displayed in its raw ASCII form. Upper case and lower case alphabetic characters may be used (A-Z, and a-z).



### 5.4.5 Instruction Code Qualifier

This is a single character that further qualifies the preceding instruction code. Code Qualifiers obey the following rules:

1. From Controller to Target, the only permitted values are:

Symbol	Definition
= (ASCII code 61)	The '=' code is used as the Assignment Operator (AO) and is used to indicate that the parameter defined by the preceding byte should be set to the value of the argument (s) which follow it. EXAMPLE: In a message from Controller-to-Target, MUT=1 would mean 'enable the mute function'.
? (ASCII code 63)	The '?' code is used as the Query Operator (QO) and is used to indicate that the Target should return the current value of the parameters defined by the preceding byte. EXAMPLE: In a message from Controller-to-Target, MUT? denotes 'return the current state of the mute function'.

2. From Target to Controller, the only permitted values are:

Symbol	Definition
= (ASCII code 61)	The '=' code is used in two ways: <ol style="list-style-type: none"> <li>a. If the controller sends a query code to a target, (EXAMPLE: MUT?, meaning 'is mute enabled or disabled?'), the target responds with MUT=x, where x represents the frequency in question, "1" being 'enabled' and "0" being 'disabled'.</li> <li>b. If the controller sends an instruction to set a parameter to a particular value, and, providing the value sent is valid, the target will acknowledge the message by replying with MUT=(with no message arguments).</li> </ol>
? (ASCII code 63)	If the controller sends an instruction to set a parameter to a particular value, and, if the value sent is not valid, the target will acknowledge the message by replying (for example) with MUT? (with no message arguments). This indicates that there was an error in the message sent by the controller.
! (ASCII code 33)	If the controller sends an instruction code that the target does not recognize, the target will acknowledge the message by echoing the invalid instruction, followed by the ! character. (EXAMPLE: XYZ!)
* (ASCII code 42)	If the controller sends an instruction to set a parameter to a particular value, and, if the value sent in the argument is valid, however, if the target is in the wrong mode, the modulator will not permit that particular parameter to be changed at this time, the target will acknowledge the message by replying, (for example), with MUT* (with no message arguments).
# (ASCII code 35)	If the controller sends an instruction code that the target cannot currently perform because of hardware resource issues, the target will acknowledge the message by echoing the invalid instruction followed by the # character. This response can only occur if the operator sends two or more 'hardware configuration' type commands without allowing adequate time between commands for the hardware to be figured. For example, if the operator issues commands to change both the frequency and the attenuation with less than 100 milliseconds between commands, and if the response # is returned, then the command was not accepted and the operator must resend the command.

### 5.4.6 Message Arguments

Arguments are not required for all messages. Arguments are ASCII codes for the characters 0 to 9 (ASCII codes 48 to 57), period (ASCII code 46) and comma (ASCII code 44).

### 5.4.7 End of Packet

Both of the following examples indicate the valid termination of a packet.

- Controller to Target: This is the 'Carriage Return' character (ASCII code 13)
- Target to Controller: This is the two-character sequence 'Carriage Return', 'Line Feed'. (ASCII code 13, and code 10.)

### 5.4.8 End of Life Commands

Certain commands (denoted by an \* in the Parameter Type field) are being marked as EOL. While these commands are fully supported in this product, it is highly recommended that the equivalent new commands be used for new implementations. The new commands will generally follow the outdated commands.

---

## 5.5 Remote Commands and Queries

### Table Indexes:

### Notes:

- 1) **Index Columns** – Where Column 'C'=Command, and Column 'Q'=Query, columns marked 'X' designate the instruction code as *Command only*, *Query only*, or *Command or Query*. Where **CODE=XXX**, this indicates a priority command.
  
- 2) **In the tables that follow, the following codes are used in the 'Response to Command' column (per Sect. 8.5.5):**

= Message ok	# Message ok, but unit is not in <b>Remote</b> mode.
? Received ok, but invalid arguments were found.	~ Time out of a pass-through message, either to via EDMAC or to a local ODU.
^ Message ok, but unit is in <b>Ethernet</b> mode.	

**Sect. 5.5.1 Customer Commands**

CODE	C	Q	PAGE
AFR	X	X	5-11
AMP	X	X	5-11
APM	X	X	5-11
ATT	X	X	5-12
AUX	X	X	5-12
CAA	X	-	5-12
CAE	X	-	5-12
CID	X	X	5-13
CLC	X	X	5-13
CSL	X	-	5-13
CWE	X	X	5-14
DAT	X	X	5-14
DAY	X	X	5-14
ESA	X	X	5-14

CODE	C	Q	PAGE
FRW	-	X	5-15
HID	-	X	5-15
HPT	X	X	5-16
IEP	X	-	5-16
IMG	X	X	5-16
IPA	X	X	5-17
IPG	X	X	5-17
ISP	X	-	5-17
LAM	X	X	5-18
LCS	X	X	5-18
LCW	X	X	5-18
LNA	-	X	5-18
LPT	X	X	5-19
LRS	X	X	5-19

CODE	C	Q	PAGE
MAC	-	X	5-19
MOP	-	X	5-20
MSK	X	X	5-21
MUT	X	X	5-22
NUE	-	X	5-22
NUS	-	X	5-22
PNM	-	X	5-22
RAS	-	X	5-23
RBT	X	-	5-25
RCS	-	X	5-25
RET	-	X	5-26
RFS	-	X	5-26
RMS	-	X	5-26
RNE	-	X	5-28

CODE	C	Q	PAGE
RNS	-	X	5-29
RUS	-	X	5-30
SAS	-	X	5-30
SBR	X	X	5-30
SBT	X	X	5-31
SFS	-	X	5-31
SNA	X	X	5-31
SNM	X	X	5-31
SNO	-	X	5-32
SPA	X	X	5-32
SRC	X	X	5-32
SSI	X	X	5-32
STA	X	X	5-32
STB	X	X	5-33

CODE	C	Q	PAGE
STV	X	X	5-33
SWC	X	X	5-33
TIM	X	X	5-33
TMP	-	X	5-33
TNA	-	X	5-34
TNE	-	X	5-34
XRM	X	X	5-34

### 5.5.1 Customer Commands

Parameter Type	Command (Instruction Code and Qualifier)	Arguments for Command or Response to Query	Description of Arguments (Note that all arguments are ASCII numeric codes between 48 and 57)	Response to Command (Target to Controller)	Query (Instruction Code and Qualifier)	Response to Query (Target to Controller)
Auto Fault Recovery	AFR=	1 byte	Command or Query. Sets the automatic fault recovery mute mode. <b>Where:</b> 1 = Automatic fault recovery enabled (unit will automatically return to its pre-fault mute state after all fault conditions clear) 0 = Automatic fault recovery disabled (unit will remain muted until the user un-mutes the output using the MUT command) <b>Example:</b> <0001/AFR=1'cr' >0001/AFR='cr''lf' <b>Default Value: 1</b>	AFR= AFR?	AFR?	AFR=x  (Same format as command arguments)
RF Power Amplifier State	AMP=	1 byte	Command or Query. Turns ON or OFF the RF power amplifiers. 0 = Off 1 = On <b>Example:</b> <1/AMP=1'cr' >0001/AMP='cr''lf' <b>Default Value: 0</b>	AMP= AMP? AMP*	AMP?	AMP=x  (Same format as command arguments)
Amplifier Power-up Mode	APM=	1 byte	Command or Query. Enables or disables the amplifier power-up mode. 0 = Disabled. Amplifier is always off at power-up. 1 = Enabled. Amplifier is set to the last user configured state at power-up (on or off depending on the AMP setting). <b>Example:</b> <1/APM=1'cr' >0001/APM='cr''lf' <b>Default Value: 0</b>	APM= APM? APM*	APM?	APM=x  (Same format as command arguments)

Parameter Type	Command (Instruction Code and Qualifier)	Arguments for Command or Response to Query	Description of Arguments (Note that all arguments are ASCII numeric codes between 48 and 57)	Response to Command (Target to Controller)	Query (Instruction Code and Qualifier)	Response to Query (Target to Controller)
Attenuation	ATT=	5 bytes	Command or Query. Set the RF attenuation level from 0 to 10dB in 0.25dB steps. <b>Example:</b> <1/ATT=10.00'cr' >0001/ATT='cr''lf' <b>Default Value: 10.00</b> <b>Default ATT Step: 0.25 dB</b>	ATT= ATT? ATT*	ATT?	ATT=xx.xx  (Same format as command arguments)
Auxiliary Mute	AUX=	1 byte	Command or Query. Enable or disable the auxiliary mute hardware control. <b>Where:</b> 1 = auxiliary mute enabled 0 = auxiliary mute disabled <b>Example:</b> <1/AUX=1'cr' >0001/AUX='cr''lf' <b>Default Value: 0</b>	AUX= AUX? AUX*	AUX?	
Clear All Stored Alarms	CAA=	None	Command only. Instructs the unit to clear all Stored Alarms. This command takes no arguments. <b>Example:</b> <1/CAA='cr' >0001/CAA='cr''lf'	CAA= CAA*	N/A	N/A
Clear All Stored Events	CAE=	None	Command only. Clear all Stored Events. This command takes no arguments. <b>Example:</b> <1/CAE='cr' >0001/CAE='cr''lf'	CAE= CAE*	N/A	N/A

Parameter Type	Command (Instruction Code and Qualifier)	Arguments for Command or Response to Query	Description of Arguments (Note that all arguments are ASCII numeric codes between 48 and 57)	Response to Command (Target to Controller)	Query (Instruction Code and Qualifier)	Response to Query (Target to Controller)
Circuit Identification	CID=	80 bytes	<p>Command or Query.</p> <p>CID is a user-defined string of data that may be used to identify or name the unit or station. The CID is an 80-byte field of data that is entered as one line, but it will be read back from the unit as two 40-byte lines of data.</p> <p><b>Examples:</b></p> <pre>&lt;1/CID= Station #001--SSPA #01--'cr' &gt;0001/CID= &lt;1/CID?'cr' &gt;0001/CID='cr' Station #001--SSPA #01--'cr'lf'</pre> <p><b>Default Value:</b></p> <pre>-----CUSTOMER ID----- -----MESSAGE-----</pre>	CID= CID? CID*	CID?	CID=x...x  (See description for details of arguments)
Calibrate LNB Current	CLC=	N/A	<p>Command or Query.</p> <p>The CLC command stores the value of the LNB Current Supply (in mA) as a reference point. The LNB current alarm point is then determined by the calibrated LNB reference point, and the LNB current window setting (see LCW command).</p> <p><b>Note:</b> this command will return a mode error if the LNB current source output has not been enabled first (see LCS command).</p> <p><b>Example:</b> &lt;1/CLC='cr' &gt;0001/CLC='cr'lf' The CLC query will return the value that was stored during the LNB current calibration.</p> <p><b>Example:</b> &lt;1/CLC?'cr' &gt;0001/CLC=xxx.x</p> <p>Where: xxx.x is the calibrated LNB current value in mA.</p> <p><b>Default Value: 000.0</b></p>	CLC= CLC? CLC*	CLC?	CLC=xxx.x  (See description for details of arguments)
Clear Statistics Log	CSL=	1 byte	<p>Command only.</p> <p>Used to clear the statistics log entries.</p> <p><b>Example:</b></p> <pre>&lt;1/CSL=1'cr' &gt;0001/CSL='cr'lf'</pre>	CSL= CSL? CSL*	N/A	CSL=

Parameter Type	Command (Instruction Code and Qualifier)	Arguments for Command or Response to Query	Description of Arguments (Note that all arguments are ASCII numeric codes between 48 and 57)	Response to Command (Target to Controller)	Query (Instruction Code and Qualifier)	Response to Query (Target to Controller)
LNB Current Window Enable	CWE=	1 bytes	Command or Query. This command allows the user to enable the current window alarm. If disabled, the LCW value will be retained, but unused. <b>Example:</b> <1/CWE=0'cr' >0001/CWE='cr''lf' <b>Default Value: 0</b>	CWE = CWE? CWE *	CWE?	CWE =x  (Same format as command arguments)
Set RTC (Real-Time-Clock) Date	DAT=	6 bytes	Command or Query. A command in the form <b>mmddy</b> , where; dd = day of the month, between 01 and 31, mm = month of the year, between 01 and 12 and yy = year, between 00 and 96 (1K OD to 2096) <b>Example</b> (date = April 24, 2003): <1/DAT=042503'cr' >0001/DAT='cr''lf'	DAT= DAT? DAT*	DAT?	DAT=xxxxxx  (Same format as command arguments)
Set RTC (Real-Time-Clock) Date	DAY=	6 bytes	Command or Query. A command in the form <b>ddmmyy</b> , where; dd = day of the month, between 01 and 31, mm = month of the year, between 01 and 12 and yy = year, between 00 and 99 (1K OD to 2099) <b>Example</b> (date = April 24, 2003): <1/DAY=240403'cr' >0001/DAY='cr''lf'	DAY= DAY? DAY*	DAY?	DAY=xxxxxx  (Same format as command arguments)
Enable Statistics Averaging	ESA=	1 byte	Command or Query. Enable or disable statistics averaging. When statistics averaging is enabled all new entries in the statistics log are comprised of averaged measurements. <b>Where:</b> 0 = Disable 1 = Enable <b>Example:</b> <0001/ESA=1'cr' >0001/ESA=1'cr''lf' <b>Default Value: 0</b>	ESA= ESA? ESA*	ESA?	



Parameter Type	Command (Instruction Code and Qualifier)	Arguments for Command or Response to Query	Description of Arguments (Note that all arguments are ASCII numeric codes between 48 and 57)	Response to Command (Target to Controller)	Query (Instruction Code and Qualifier)	Response to Query (Target to Controller)
Retrieve Firmware Number	N/A		Query only. Returns the firmware type(s) loaded into the unit. The firmware information is returned in the following format: FW-AAAAAAA B.B.BB DD/MM/YY <b>Where:</b> FW-AAAAAAA = the firmware part number B.B.BB = the version number DD/MM/YY = Day/Month/Year firmware released <b>Example:</b> <1/FRW?'cr' >0001/FRW= Boot: FW-0000082 0.0.1a 04/09/08 Bulk1: FW-0000078 0.0.1a 04/09/08 FW-0000080 0.0.1a 04/09/08 FW-0000081 0.0.1a 04/09/08 Bulk2: FW-0000078 0.0.1a 04/09/08 FW-0000080 0.0.1a 04/09/08 FW-0000081 0.0.1a 04/09/08	FRW=	FRW?	FRW={CR}Bo ot:{CR}abc{C R}Bulk1:{CR}a bc{CR}abc  (See description for details of arguments)
Hardware ID	N/A	1 byte	Query only. Returns the value of the Hardware ID byte. <b>Example:</b> <0001/HID?'cr' >0001/HID=0'cr''lf'	HID=	HID?	HID=x

Parameter Type	Command (Instruction Code and Qualifier)	Arguments for Command or Response to Query	Description of Arguments (Note that all arguments are ASCII numeric codes between 48 and 57)	Response to Command (Target to Controller)	Query (Instruction Code and Qualifier)	Response to Query (Target to Controller)
High Power Threshold	HPT=	5 bytes	Command or Query. This command allows the user to set the threshold for the high forward power alarm/fault. If the forward power rises above the specified value, the alarm/fault will be indicated. Setting this parameter to 00.00 effectively disables the threshold. HPT=xx.xx, <b>Where:</b> xx.xx = a real number between <del>48.00</del> 37.00 and <del>64.00</del> 57.00 dBm. (Glenn note: This was wrong for the 1kW, it was 40-60 dBm.) <b>Example:</b> <1/HPT=56.00'cr' >0001/HPT='cr'lf' <b>Default Value: 00.00</b>	HPT= HPT? HPT*	HPT?	High Power Threshold
Initialize Events Pointer	IEP=	None	Command only. Resets internal pointer to allow RNE? Queries to start at the beginning of the stored events log. <b>Example:</b> <1/IEP='cr' >0001/IEP='cr'lf'	IEP= IEP? IEP*	N/A	N/A
Software Image	IMG=	1 byte	Command or Query. Current Active software image, <b>Where:</b> 1=Bulk Image # 1 currently active 2=Bulk Image # 2 currently active <b>Examples:</b> <1/IMG=1'cr' (instructs the unit to load firmware from image #1 at the next reset / power up). <1/IMG?'cr' (queries the image number that the firmware loaded during bootup) <b>Note:</b> If the user sends the IMG command, and then queries the IMG value, the numbers may not be equal because the command tells the firmware which image to boot from at the next bootup, and the query reports the image that the firmware booted from on the last bootup.	IMG= IMG? IMG* IMG#	IMG?	IMG=x  (See description for details of arguments)

Parameter Type	Command (Instruction Code and Qualifier)	Arguments for Command or Response to Query	Description of Arguments (Note that all arguments are ASCII numeric codes between 48 and 57)	Response to Command (Target to Controller)	Query (Instruction Code and Qualifier)	Response to Query (Target to Controller)
IP Address	IPA=	18 bytes	Command or Query. Used to set the IP address and network prefix for the 10/100 BaseT Ethernet management port, in the format: xxx.xxx.xxx.xxx.yy, <b>Where:</b> xxx.xxx.xxx.xxx is the IP address, and yy is the network prefix (8-30) <b>Example:</b> <1/IPG=192.168.001.004.24'cr' >0001/IPG='cr''lf' <b>Note:</b> Changing the IP address through the Telnet interface requires the user to power cycle the unit, and then restart a new Telnet session with the new IP address. The IP address typed into the Telnet client software does not include the range parameter, so it would be: 192.168.1.4. <b>Default Value: 192.168.001.004.24</b>	IPA= IPA? IPA* IPA#	IPA?	IPA= xx.xxx.xxx.xxx .yy  (See description of arguments)
Gateway Address	IPG=	15 bytes	Command or Query. Used to set the Gateway IP address for the 10/100 Base Tx Ethernet management port, in the format: xxx.xxx.xxx.xxx, <b>Where:</b> xxx.xxx.xxx.xxx is the IP address <b>Example:</b> <1/IPG=192.168.001.005'cr' >0001/IPG='cr''lf' <b>Default Value: 192.168.001.005</b>	IPG= IPG? IPG*	IPG?	IPG = xxx.xxx.xxx.xx x
Initialize Statistics Pointer	ISP=	None	Command only. Resets internal pointer to allow RNS? Queries to start at the beginning of the statistics log. <b>Example:</b> <1/ISP='cr' >0001/ISP='cr''lf'	ISP= ISP? ISP*	N/A	N/A

Parameter Type	Command (Instruction Code and Qualifier)	Arguments for Command or Response to Query	Description of Arguments (Note that all arguments are ASCII numeric codes between 48 and 57)	Response to Command (Target to Controller)	Query (Instruction Code and Qualifier)	Response to Query (Target to Controller)
Lamp Test	LAM=	1 byte	Command or Query. Lamp test mode, <b>Where:</b> 0 = Disable LED (turn off) 1 = Enable (Tri-color LED light) 2 = Test (cycles through colors once) <b>Example:</b> <0001/LAM=1'cr' >0001/LAM=1'cr'lf' <b>Default Value: 0</b>	LAM=	LAM?	LAM=x
LNB Current Source	LCS=	1 byte	Command or Query. This command enables, or disables the LNB current source. Note: LCS must be enabled before the LNB current can be calibrated. 0 = Disable 1 = Enable <b>Example:</b> <1/LCS=1'cr' >0001/LCS='cr'lf' <b>Default Value: 0</b>	LCS= LCS? LCS*	LCS?	LCS=x  (Same format as command arguments)
LNB Current Window	LCW=	2 bytes	Command or Query. This command allows the user to set the alarm window in $\pm$ % of the calibrated LNB Current. Valid inputs are 20 to 50 in increments of 1%. In addition, setting the value to 99 <sup>1</sup> disables the alarm function. <b>*Note:</b> A return value of 99 indicates that the current window is disabled. This may be because a value of 99 was set for LCW, or it may be because the CWE has been disabled. Since the method of setting 99 to this command is being obsoleted, it is recommended the user utilize CWE instead of 99. The following example will set the alarm window to $\pm$ 30%. <b>Example:</b> <1/LCW=30'cr' >0001/LCW='cr'lf' <b>Default Value: 30</b>	LCW= LCW? LCW*	LCW?	LCW=xx  (Same format as command arguments)
Retrieve next 5 unread Stored Alarms	N/A	145 bytes	Query only. See RNE query.	LNA=	LNA?	See RNE query

Parameter Type	Command (Instruction Code and Qualifier)	Arguments for Command or Response to Query	Description of Arguments (Note that all arguments are ASCII numeric codes between 48 and 57)	Response to Command (Target to Controller)	Query (Instruction Code and Qualifier)	Response to Query (Target to Controller)
Low forward Power Threshold	LPT=	5 bytes	<p>Command or Query.</p> <p>This command allows the user to set the threshold for the low forward power alarm/fault. If the forward power drops below the specified value, the alarm/fault will be indicated. Setting this parameter to 00.00 effectively disables the threshold.</p> <p>LPT=xx.xx</p> <p><b>Where:</b> xx.xx = a real number between 7.00 and 27.00 dBm</p> <p><b>Example:</b> &lt;0001/LPT=00.00'cr' &gt;0001LPT='cr''lf'</p> <p><b>Default Value: 00.00</b></p>	LPT = LPT? LPT *	LPT?	LPT =xxx.x  (Same format as command arguments)
Local Remote State	LRS=	1 byte	<p>Command or Query.</p> <p>Set Local or Remote for Indoor SSPA. Always in remote mode for Outdoor SSPA</p> <p>1 = Serial 2 = Ethernet 3 = Serial+Ethernet</p> <p><b>Example:</b> &lt;1/LRS=3'cr' &gt;0001/LRS='cr''lf'</p> <p><b>Note:</b> The user will always have query access in any mode. Also, the LRS command is available in all modes as a means of acquiring control. The intent of this command is to limit changes from being made on multiple interfaces at the same time. The web page GUI will refuse connections unless LRS is set to enable Ethernet remote control.</p> <p><b>Default Value: 3 (Serial+Ethernet)</b></p>	LRS= LRS?	LRS?	LRS=x  (Same format as command arguments)
Unit MAC Address	N/A	17 bytes	<p>Query only.</p> <p>MAC address of the unit, reported in hexadecimal.</p> <p><b>Example:</b> &lt;0001/MAC?'cr' &gt;0001/MAC=00-06-B0-00-D2-A7'cr''lf'</p>	MAC=	MAC?	MAC=xx-xx-xx-xx-xx-xx  (See description for details of arguments)

Parameter Type	Command (Instruction Code and Qualifier)	Arguments for Command or Response to Query	Description of Arguments (Note that all arguments are ASCII numeric codes between 48 and 57)	Response to Command (Target to Controller)	Query (Instruction Code and Qualifier)	Response to Query (Target to Controller)
Maximum Operating Points	N/A	1 bytes (command) 810 bytes (response)	Query only. Used to view maximum operating points <b>Where:</b> MAX is Maximum MIN is Minimum FWPWR = Forward Power (dBm) ATEMP = Amplifier Heat Sink Temperature (deg C) OTEMP = Outside Temperature (deg C) (100W/250W) RVPWR = Reverse Power (dBm) (100W/250W) INPWR = Input Power (dBm) (250W) ETEMP = Exhaust Temperature (deg C) (250W) RF40I = RF 40V current (amps) (250W) RF24I = 24V RF current (50W/100W) PS24I = 24V PS current AC Volt = AC Vrms (100W/250W) AC Curr = AC Irms (amps) (100W/250W) AC VPEAK = AC Volt Peak (100W/250W) AC WATT = AC Watts (100W/250W) AC LINE = AC Line Frequency (Hz) (100W/250W) <b>Example:</b> <1/mop? >1/MOP= 10-06-19 09:46:51 MAX SYS FWPWR=<23.0 10-06-19 09:46:51 MAX RF ATEMP=028.7 10-06-19 09:56:43 MIN RF ATEMP=027.2 10-06-19 09:59:26 MAX SYS OTEMP=036.9 10-06-19 09:48:02 MIN SYS OTEMP=034.2 10-06-19 09:46:51 MAX SYS RVPWR=<25.0 10-06-19 10:00:26 MAX RF 24I=14.7 10-06-19 09:59:22 MAX SYS PS24I=08.6 10-06-19 09:56:35 MAX PS AC Volt=207.6 10-06-19 10:00:24 MIN PS AC Volt=206.2 10-06-19 10:00:24 MAX PS AC Curr=03.33 10-06-19 09:56:35 MIN PS AC Curr=00.45 10-06-19 09:56:35 MAX PS AC VPEAK=290.8 10-06-19 10:00:24 MIN PS AC VPEAK=288.7	MOP= MOP*	MOP?	MOP=x  (See description for details of return string)

Parameter Type	Command (Instruction Code and Qualifier)	Arguments for Command or Response to Query	Description of Arguments (Note that all arguments are ASCII numeric codes between 48 and 57)	Response to Command (Target to Controller)	Query (Instruction Code and Qualifier)	Response to Query (Target to Controller)
Maximum Operating Points (Cont)			10-06-19 09:48:17 MAX PS AC WATT=83080.8 10-06-19 09:57:41 MIN PS AC WATT=83073.4 10-06-19 09:48:23 MAX PS AC LINE=60.03 10-06-19 09:59:36 MIN PS AC LINE=59.98			
Unit Alarm Mask	MSK=	7 bytes	<p>Command or Query. Alarm mask conditions. If the mask value for a certain parameter is set to fault, then a fault condition will be registered if specified hardware conditions are not met. If the mask value is set to alarm, then a fault condition will only appear to be an alarm that will not set the summary fault relay. If the mask value is set to masked, then the fault will never be reported to the user.</p> <p>Form of: abcdef</p> <p><b>Where:</b></p> <ul style="list-style-type: none"> <li>0 = Fault</li> <li>1 = Alarm</li> <li>2 = Masked</li> <li>a = RF Fan 1 Speed</li> <li>b = RF Fan 2 Speed</li> <li>c = PS Fan Speed</li> <li>d= Input Power</li> <li>e= Reverse Power</li> <li>f= Low Forward Power</li> <li>g = High Forward Power</li> <li>h = External Reference Lock detect</li> <li>i = LNB Current Detect</li> <li>j = LNB 22V Power Supply</li> </ul> <p><b>Example:</b></p> <pre>&lt;0001/MSK=1112022222'cr'</pre> <pre>&gt;0001/MSK='cr''lf'</pre> <p><b>Default Value: 1112022222</b></p>	MSK= MSK? MSK*	MSK?	MSK=abcdef  (See description for details of arguments)

Parameter Type	Command (Instruction Code and Qualifier)	Arguments for Command or Response to Query	Description of Arguments (Note that all arguments are ASCII numeric codes between 48 and 57)	Response to Command (Target to Controller)	Query (Instruction Code and Qualifier)	Response to Query (Target to Controller)
Mute State	MUT=	1 byte	Command or Query. Mute the unit <b>Where:</b> 0 = Disable (Not Muted) 1 = Enable (Muted) 2 = Aux Mute (Muted) [Query Only, AUX] <b>Example:</b> <1/MUT=1'cr' >0001/MUT=1'cr''lf' <b>Default Value: 0</b>	MUT= MUT? MUT*	MUT?	MUT=x  (Same format as command arguments)
Number of Unread Stored Events	N/A	3 bytes	Query only. Unit returns the Number of stored Events, which remain Unread in the form of xxx. <b>Example:</b> <1/NUE?'cr' >0001/NUE=126'cr''lf'	NUE=	NUE?	NUE=xxx
Number of Unread Stored Statistics	N/A	3 bytes	Query only. Unit returns the Number of stored Statistics, which remain Unread in the form of xxx. <b>Example:</b> NUS=126	NUS=	NUS?	NUS=xxx
Equipment Odometer	N/A	6 bytes	Query. Used to view or clear the equipment odometer (stored in non-volatile memory) in the format of aaaaaaaaaa <b>Where:</b> aaaaaaaaaa = The time in hours of the odometer. <b>Example:</b> EOD?	EOD= EOD*	EOD?	EOD=aaaaaa  (see description for details of return string)
Part Number	N/A	96 bytes alphanumeric	Query only. The PNM query will return the DOTCODE string that was loaded into the unit. <b>Example:</b> <1/PNM? >0001/PNM=TRP0.0000000200'cr''lf'	PNM= PNM? PNM *	PNM?	PNM=x....x  (See description for details of return string)



Parameter Type	Command (Instruction Code and Qualifier)	Arguments for Command or Response to Query	Description of Arguments (Note that all arguments are ASCII numeric codes between 48 and 57)	Response to Command (Target to Controller)	Query (Instruction Code and Qualifier)	Response to Query (Target to Controller)
Retrieve Alarm Status	N/A	Variable # bytes	<p>Query only. The unit returns the alarm state for the following sections: RAS? The Alarm status of the unit, <b>Where:</b> OK = no fault condition FT = faulted AL = alarm MS = masked NA= Not applicable <b>System Alarm Status where:</b> SYS-FWPWR = System Forward Power SYS-RVPWR = System Reverse Power (100W/250W) SYS-INPWR = System Input Power (250W) SYS-INTMP = Internal Temperatures SYS-OTEMP = Outside Temperatures (100W/250W) SYS-RFOVR = RF Overdrive SYS-BUCLD = BUC Lock Detect SYS-XRFLD = External Reference Lock Detect SYS-LNBCS = LNB Current Source SYS-LNBPS = LNB Voltage SYS-SWTCH = Waveguide Switch SYS-REDLK = Redundant Link Status <b>RF Module Alarm Status where:</b> RF-ATEMP = Heat Sink Temperature RF-RFAN1 = RF Module Fan 1 (100W/250W) RF-RFAN2 = RF Module Fan 2 (250W) <b>Power Supply Alarm Status where:</b> PS-RF40V = 40V RF Power Supply (250W) PS-RF40I = 40V RF Current Power Supply (250W) PS-RF10V = 10V RF Power Supply (250W) PS-P3V6T = +3.6V Power Supply (250W) PS-RF24V = 24V RF Power Supply (50W/100W) PS-RF24I = 24V RF Current Power Supply (50W/100W) PS-P7V8T = +7.8V Power Supply (50W/100W) PS-PS24V = 24V Power Supply</p>	RAS=	RAS?	RAS=x...x  (See description for details of arguments)

Parameter Type	Command (Instruction Code and Qualifier)	Arguments for Command or Response to Query	Description of Arguments (Note that all arguments are ASCII numeric codes between 48 and 57)	Response to Command (Target to Controller)	Query (Instruction Code and Qualifier)	Response to Query (Target to Controller)
Retrieve Alarm Status (cont)			PS-PS24I = 24V current Power Supply PS-PS13V = 13.5V Power Supply PS-P5V8T = +5.8V Power Supply PS-P5V0T = +5.0V Power Supply PS-P3V3T = +3.3V Power Supply PS-PN5V8 = -5.8V Power Supply PS-PFAN1 = Power Supply Module Fan 1 PS-VRMS = AC Vrms (100W/250W) PS-LnFrq = AC Line Frequency (100W/250W) <b>Example:</b> <1/RAS?'cr' >0001/RAS= SYS-FWPWR=NA SYS-INTMP=FLT SYS-RFOVR=OK SYS-BUCLD=FLT SYS-XRFLD=NA SYS-LNBCR=NA SYS-LNBPS=NA SYS-SWTCH=NA SYS-REDLK=NA RF-ATEMP=OK PS-RF24V=NA PS-PS24V=FLT PS-PS13V=FLT PS-P7V8T=FLT PS-P5V8T=OK PS-P5V0T=OK PS-P3V3T=OK PS-PN5V8=FLT PS-RF24I=NA PS-PS24I=OK PS-PFAN1=OK			

Parameter Type	Command (Instruction Code and Qualifier)	Arguments for Command or Response to Query	Description of Arguments (Note that all arguments are ASCII numeric codes between 48 and 57)	Response to Command (Target to Controller)	Query (Instruction Code and Qualifier)	Response to Query (Target to Controller)
Reboot	RBT=	1 byte	Command only. Soft Reboot 1 = Reboot System <b>Example:</b> <1/RBT=1	RBT = RBT? RBT*	N/A	RBT=x  (See description for details of arguments)
Retrieve Configuration Status	N/A		Query only. Used to query the configuration status of the unit. <b>Where:</b> AMP = RF power amplifier state 0 = OFF 1 = ON MUT = RF mute state 0 = un-muted 1 = muted ONL = Online status for redundancy ESW = Redundancy state and mode, states: 0 = OFF 1 = ON Tx only 2 = ON Tx & Rx AOF = Attenuator Offset in dB AFR = auto fault recovery, 0 = manual 1 = auto XRF = External reference status, N/A = no external reference, 05M for 5 MHz, and 10M for a 10 MHz LRS = 1-Serial, 2-Ethernet, 3-Serial and Ethernet <b>Example:</b> RCS = 'cr' AMP = 1'cr' MUT = 1'cr' ONL = 1'cr' ESW = 1'cr' AOF = 00.00'cr' AFR = 1'cr' XRF = N/A'cr'	RCS=	RCS?	RCS=x...x  (See description for details of arguments)

Parameter Type	Command (Instruction Code and Qualifier)	Arguments for Command or Response to Query	Description of Arguments (Note that all arguments are ASCII numeric codes between 48 and 57)	Response to Command (Target to Controller)	Query (Instruction Code and Qualifier)	Response to Query (Target to Controller)
Retrieve Configuration Status (Cont)			LRS = 1'lf' (see <b>Note</b> ) <b>Note:</b> XRF will always be N/A if the internal reference oscillator option is <b>not</b> installed.			
Retrieve Equipment Type	N/A	22 bytes	Query only. The unit returns a string indicating the Model Number and the version of the M&C firmware installed in the unit. <b>Example:</b> <1/RET?'cr' >0001/RET= TRP500-4450-C-OD VER: 1.1.1'cr'lf'	RET=	RET?	RET=x....x  (See description for details of arguments)
RF Power FET Current Status	N/A	Variable length, depending on the number of FETs installed in the RF amplifier	Query only. Used to display all the FET currents. <b>Example:</b> <0001/RFS? >0001/RFS= Q01=.000 Q02=.000 Q03=.000 Q04=.000	RFS=	RFS?	RFS=x....x  (See description of arguments)
Retrieve Maintenance Status	N/A	Varies depending on hardware	Query only. Response dependent on configuration. The unit returns the maintenance status as follows: RMS?X <b>Where:</b> X= 'cr', 1'cr' 'cr' = Power Supply 1 = RF Module <b>Power Supply:</b> PFAN1 = PS Fan Speed in Percent PS24V = PS 24V Voltage PS24V = PS 24V Current PS13V = PS 13.5V Voltage P5V8T = 5.8V Voltage P5V0T = 5.0V Voltage P3V6T = 3.6V Voltage (250W) P3V3T = 3.3V Voltage	RMS= RMS*	RMS?	RMS=x....x  (See description for details of arguments)

Parameter Type	Command (Instruction Code and Qualifier)	Arguments for Command or Response to Query	Description of Arguments (Note that all arguments are ASCII numeric codes between 48 and 57)	Response to Command (Target to Controller)	Query (Instruction Code and Qualifier)	Response to Query (Target to Controller)
Retrieve Maintenance Status (Cont)			PN5V8 = -5.8V Voltage RF24V = RF 24V Voltage (50W/100W) RF24I = RF 24V Current (50W/100W) P7V8T = PS 7.8V Voltage (50W) RF40V = RF 40V Voltage (250W) RF40I = RF 40V Current (250W) RF10V = RF 10.0V Voltage (250W) VRMS = AC Vrms Voltage (100W/250W) Irms = AC Irms Current (100W/250W) Vpeak = AC Peak Voltage (100W/250W) Watts = AC Watts (100W/250W) AC_VA = AC VA (100W/250W) AC_PF = AC Power Factor (100W/250W) LFREQ = AC Line Frequency (HZ) (100W/250W) <b>RF Module:</b> FWPWR = Module RF Forward Power in dBm ATEMP = Module Heatsink Temperature in deg C REFVT = Reference Tune Voltage (Internal Reference) LNB I = LNB current (LNB) LNB V = LNB Voltage (LNB) SW24V = Redundant Wave Guide Switch Voltage RVPWR = Reverse RF Power in dBm (100W/250W) RFAN1 = RF Module FAN 1 (100W/250W) OTEMP = Outside Temperature in deg C (100W/250W) INPWR = Module Input Power in dBm (250W) ETEMP = Exhaust Temperature in deg C (250W) RFAN2 = RF Module FAN 2 (250W) <b>Example:</b> <1/rms? PFAN1=000.0 RF24V=000.0 PS24V=000.0 PS13V=000.0 P7V8T=000.0 P5V8T=005.9 P5V0T=005.1			

Parameter Type	Command (Instruction Code and Qualifier)	Arguments for Command or Response to Query	Description of Arguments (Note that all arguments are ASCII numeric codes between 48 and 57)	Response to Command (Target to Controller)	Query (Instruction Code and Qualifier)	Response to Query (Target to Controller)
Retrieve Maintenance Status (Cont)			P3V3T=003.3 PN5V8=-00.0 RF24I=000.0 PS24I=-01.5 LNB I=283.4 LNB V=000.0 SW24V=000.0			
Retrieve Next 5 Unread Stored Events	N/A	xx bytes	Query only. Unit returns the oldest 5 Stored Events which have not yet been read over the remote control. Reply format: {CR}Sub-body{CR}Sub-body{CR}Sub-body{CR} Sub-body{CR}Sub-body, <b>Where:</b> Sub-body= ddmmyyhhmmssABCC: <b>Where:</b> A being the fault type SYS= System RF = RF Module PS = PS Module B being the fault/clear indicator. FLT=Fault OK=Clear INF=Info NA= Not Applicable MSK= Masked ALM= Alarm CC is Fault or Alarm description:  <b>Example:</b> <1/RNE? >1/RNE= 06-22-15 11:57:50 PS FLT +13.5V PS 06-22-15 11:57:50 RF ALM Heat Sink Temp 06-22-15 11:57:50 RF FLT BUC LOCK DETECT 06-22-15 11:57:51 PS FLT +24V PS	RNE=	RNE?	RNE={CR}AB CCddmmyyhh mmss{CR}AB CCddmmyyhh mmss{CR}AB CCddmmyyhh mmss{CR}AB CCddmmyyhh mmss{CR}AB CCddmmyyhh mm mss  (See description for details of arguments)

Parameter Type	Command (Instruction Code and Qualifier)	Arguments for Command or Response to Query	Description of Arguments (Note that all arguments are ASCII numeric codes between 48 and 57)	Response to Command (Target to Controller)	Query (Instruction Code and Qualifier)	Response to Query (Target to Controller)
Read Next 5 Statistics	N/A	436 bytes, alpha-numeric	<p>Query only. Response dependent on configuration. Returns the next five unread statistics stored in the statistics log. Returns 5 lines with the following format: mm-dd-yy;HH:MM:SS;a;b;c;dd.dd;ee.ee;ff.ff;gg.gg;hh.hh;ii.ii;jj.jj; kk.k;ll.l;mm.m;nn.n;oo.o;ppp;qqq;rrrr;ss.s;tt.t, <b>Where:</b> mm-dd-yy = entry date HH:MM:SS = entry time a = amplifier enable state (1=on,0=off) b = mute enable state (1=on,0=off) c = Online state (1=online, 0=offline) dd.dd = RF attenuation (dB) ee.e = forward power monitor (dBm) ff.f = Reverse Power (dBm) (100W/250W) gg.g = Outside Temperature (deg C) (100W/250W) hh.h = Input Power (dBm) (250W) ii.i = Exhaust Temperature (deg C) (250W) jj.j = RF 24V (50W/100W) kk.k = RF 24V current (amps) (50W/100W) ll.l = RF 40V (250W) mm.m = RF 40V current (amps) (250W) nn.n = RF 10V (250W) ppp = AC Vrms (100W/250W) qqq = AC Irms (amps) (100W/250W) rrrr = AC Watts (100W/250W) ss.s = AC Line Frequency (Hz) (100W/250W) tt.t = Heat Sink Temperature (deg C)</p> <p><b>Example:</b> "h" or "H" prints a header &lt;1/rns?h &lt;1/rns?h &gt;1/RNS= Date Time A M O ATTEN FPWR RF24VRF24I ATP 006 [005] -10-04;19:07:43:26:0;0;1;00.00;00.0;00.0;00.0;35.5 007 [006] -10-04-19:07:44:26:0;0;1;00.00;00.0;00.0;00.0;33.4 008 [007] -10-04-19:07:45:26:0;0;1;00.00;00.0;00.0;00.0;31.5</p>	RNS=	RNS?	RNS=x...x  (See description for details of arguments)

Parameter Type	Command (Instruction Code and Qualifier)	Arguments for Command or Response to Query	Description of Arguments (Note that all arguments are ASCII numeric codes between 48 and 57)	Response to Command (Target to Controller)	Query (Instruction Code and Qualifier)	Response to Query (Target to Controller)
Retrieve Utility Status	N/A	23 bytes, alpha-numeric	Query only. Used to Query the utility status of the unit. <b>Where:</b> ADR = the serial address BDR = the serial baud rate FMT = the serial format	RUS=	RUS?	RUS=x...x  (See description for details of arguments)
Summary Alarm Status	N/A	1 byte	Query only. Indicates if there are any active alarm conditions. SAS=x, <b>Where:</b> 0 = no active alarms 1 = at least one active alarm <b>Example:</b> <1/SAS? >0001/SAS=0'cr'lf'	SAS=	SAS?	SAS=x  (See description for details of arguments)
Remote Baud Rate	SBR=	5 bytes	Command or Query. Set remote baud rate as follows: 02400 = 2400 baud 04800 = 4800 baud 09600 = 9600 baud 19200 = 19200 baud 38400 = 38400 baud <b>Examples:</b> <0001/SBR=9600'cr' >0001/SBR='cr'lf' <0001/SBR?'cr' >0001/SBR=09600'cr'lf' <b>Note:</b> When changing baud rates remotely the response to the command will be returned using the same baud rate as that used to send the command. <b>Default Value: 09600</b>	SBR= SBR? SBR*	SBR?	SBR=xxxxx  (Same format as command arguments)



Parameter Type	Command (Instruction Code and Qualifier)	Arguments for Command or Response to Query	Description of Arguments (Note that all arguments are ASCII numeric codes between 48 and 57)	Response to Command (Target to Controller)	Query (Instruction Code and Qualifier)	Response to Query (Target to Controller)
Switch Bias Tee	SBT=	1 byte numeric	Command or Query. Switches the bias tee into the through state, or into the off state. The bias tee provides a means of muting the LNB. The SBT state will be controlled by the amplifier mute state while running in redundant mode, but while the unit is not in redundant mode the bias tee may be set independently of the amplifier mute state. 0 = Off State (mute LNB) 1 = Through State (unmute LNB) <b>Example:</b> <1/SBT=1 <b>Note:</b> To send this command the unit must have the bias tee option installed otherwise a mode error will result. A mode error will also result if this command is sent while the unit is running in redundant mode. <b>Default Value: 0</b>	SBT= SBT? SBT*	SBT?	SBT=x  (See description for details of arguments)
Summary Fault Status	N/A	1 byte	Query only. Indicates the condition of the summary fault relay. <b>Where:</b> 0 = Not Faulted (SumFLT_COM J6 pin K is not connected to SumFLT_NC J6 pin M) 1 = Faulted (SumFLT_COM J6 pin K is connected to SumFLT_NC J6 pin M) <b>Example:</b> <1/SFS? >0001/SFS=0'cr'lf'	SFS=	SFS?	SFS=x  (See description for details of arguments)
SNMP Authentication Trap Enable	SNA=	1 byte	Command or Query. SNMP Authentication Trap Enable 0 = Disabled 1 = Enabled <b>Example:</b> <1/SNA=0	SNA= SNA?	SNA?	SNA=x  (See description for details of arguments)
SNMP Enable	SNM=	1 byte	Command or Query. SNMP Enable. 0 = Disabled 1 = Enabled <b>Example:</b> <1/SNM=0	SNM= SNM?	SNM?	SNM=x  (See description for details of arguments)

Parameter Type	Command (Instruction Code and Qualifier)	Arguments for Command or Response to Query	Description of Arguments (Note that all arguments are ASCII numeric codes between 48 and 57)	Response to Command (Target to Controller)	Query (Instruction Code and Qualifier)	Response to Query (Target to Controller)
Serial Number	N/A	9 bytes	Query only. Used to Query the unit's nine-digit serial number in the form of SNO=xxxxxxx, <b>Where:</b> xxxxxxx is the unit's nine-digit serial number. <b>Note:</b> This command is functionally identical to RSN. <b>Example:</b> <1/SNO?'cr' >0001/SNO=072282040'cr''lf'	SNO=	SNO?	SNO=xxxxxx xx  (See description for details of arguments)
Remote Address	SPA=	4 bytes	Command or Query. Set Physical Address-between 0001 to 9999. Resolution 0001 <b>Example:</b> <1/SPA=0412'cr' >0001/SPA='cr''lf' <b>Default Value: 0001</b>	SPA=	SPA?	SPA=xxxx  (Same format as command arguments)
SNMP Read Community	SRC=	16 bytes, characters, no spaces	Command or Query. SNMP read community string. Empty string is not allowed <b>Example:</b> <1/SRC=public	SRC = SRC!	SRC?	SRC =x  (See description of arguments)
Set Statistics Interval	SSI=	2 bytes	Command or Query. Sets the interval at which statistics are logged. Minimum resolution is 1 minute, maximum is 99 minutes. <b>Example:</b> <1/SSI=90'cr' >0001/SSI='cr''lf' <b>Default Value: 60</b>	SSI= SSI?	SSI?	SSI=xx  (Same format as command arguments)
SNMP Trap Destination IP Address 1	STA=	15 bytes, Numerical	Command or Query. Used to set the IP address of the first SNMP Trap destination IP Address 1 <b>Where</b> traps will be sent in the form: xxx.xxx.xxx.xxx is the IP address <b>Example:</b> <1/STA=010.006.030.001 When not configured, returns >0001/STA=0.0.0.0	STA = STA!	STA?	STA=xxx.xxx.x xx.xxx  (See description of arguments)

Parameter Type	Command (Instruction Code and Qualifier)	Arguments for Command or Response to Query	Description of Arguments (Note that all arguments are ASCII numeric codes between 48 and 57)	Response to Command (Target to Controller)	Query (Instruction Code and Qualifier)	Response to Query (Target to Controller)
SNMP Trap Destination IP Address 2	STB=	15 bytes, Numerical	Command or Query. Used to set the IP address of the first SNMP Trap destination IP Address 2 <b>Where</b> traps will be sent, in the form: xxx.xxx.xxx.xxx is the IP addresss <b>Example:</b> <1/STB=010.006.030.001 When not configured, returns >0001/STB=0.0.0.0	STB = STB!	STB?	STB=xxx.xxx.x xx.xxx  (See description of arguments)
SNMP Trap Version	STV=	1 byte	Command or Query. SNMP Trap Version that will be used to send traps. 1 = SNMP Trap Version 1 2 = SNMP Trap Version 2 <b>Example:</b> <1/STV=0	STV = STV!	STV?	STV =x  (See description of arguments)
SNMP Write Community	SWC=	16bytes, characters, no spaces	Command or Query. SNMP write community string. Empty string is not allowed <b>Example:</b> <1/SWC=private	SWC = SWC!	SWC?	SWC =x  (See description of arguments)
Set RTC Time	TIM=	6 bytes	Command or Query. A command in the form <b>hhmmss</b> , indicating the time from midnight, where hh = hours, between 00 and 23; mm = minutes, between 00 and 59, and ss = seconds, between 00 and 59 <b>Example:</b> (time = 23 hours, 12 minutes and 59 seconds since midnight): <1/TIM=231259'cr' >0001/TIM='cr'lf'	TIM = TIM? TIM *	TIM?	TIM=xxxxxx  (Same format as command arguments)
Temperature	N/A	7 bytes	Query only. Returns the specified temperature. <b>Where:</b> 0 = RF Module Heatsink Temp <b>Example:</b> <1/TMP?0'cr' >0001/TMP=+052.27'cr'lf'	TMP=	TMP?	TMP=x  (See description for details of arguments)

Parameter Type	Command (Instruction Code and Qualifier)	Arguments for Command or Response to Query	Description of Arguments (Note that all arguments are ASCII numeric codes between 48 and 57)	Response to Command (Target to Controller)	Query (Instruction Code and Qualifier)	Response to Query (Target to Controller)
Retrieve Number of Unread Stored Alarms	N/A	2 bytes	Query only. Returns the number of stored events, which remain unread in the alarm log. <b>Example:</b> <1/TNA? 'cr' >0001/TNA=14'cr'lf'	TNA=	TNA?	TNA=xx  (See description for details of arguments)
Total Number of Events	N/A	2 bytes	Query only. Returns the number of unread entries in the stored events log. <b>Example:</b> <1/TNE? 'cr' >0001/TNE=14'cr'lf'	TNE=	TNE?	TNE=xx (See description for details of arguments)
External Reference Mute	XRM=	1 byte numeric	Command or Query. Enables or disables the external reference not present mute. When the XRM command is enabled the unit will mute if an external reference oscillator is not detected. Where: 0 = Disable 1 = *Enable <b>Example:</b> <1/XRM=1'cr' <b>Note:</b> To enable this command the internal reference oscillator option must be installed; otherwise, a mode error will result. A hardware mute condition generated by the XRM mute is one of the conditions that can cause the MUT command to return MUT=2.	XRM= XRM? MSK*	XRM?	XRM=x  (See description for details of arguments)

# Appendix A. CABLE DRAWINGS

---

## A.1 Overview

This appendix provides line details for the cables available for use with the LGaN in Standalone applications. Each figure illustrates the cable's technical specifications – e.g., connector types used, cable labeling, wiring lists, etc.



**The tables in this appendix cross-reference cable use in LGaN Standalone applications.**



**The European EMC Directive (EN55022, EN50082-1) requires that you use properly shielded cables for DATA I/O. These cables must be double-shielded from end-to-end, ensuring a continuous ground shield.**

## A.2 Control and Data Cables

FIG	CEFD CABLE P/N	DESCRIPTION	USED FOR:	REF App A FIG
Figure A-1	CA-0020526	Serial Interface Cable (19-pin circular connector to RJ-11)	Connecting Standalone LGaN 'J6   COM1' receptacle to CLC-10 RJ-11 communications jack <i>(Cable and CLC-10 are furnished as part of optional CEFD KIT KT-0020518)</i>	A-1, A-3, A-12 through A-30
Figure A-2	CA-0000352	Ethernet Interface Cable (19-pin circular connector to <2X> RJ-45)	Connecting Standalone LGaN 'J6   COM1' receptacle to LGaNnet Ethernet jack <i>(Cable and LGaNnet are furnished as part of optional CEFD KIT KT-0000203)</i>	A-2, A-3, A-12 through A-30
Figure A-3	CA-0000318	100' COMMS Cable (19-pin circular connector to bare end)	Connecting Standalone LGaN 'J6   COM1' receptacle to user-specified M&C interface	A-3, A-12 through A-30
Figure A-4	CA-0000543	250' COMMS Cable (19-pin circular connector to bare end)		A-3, A-12 through A-30

## A.2.1 Serial Interface Cable

The CEFD CLC-10 Serial M&C Accessory Kit (CEFD P/N KT-0020518) includes the CA-0020526 Serial Interface Cable. This kit is optionally available to provide serial-based monitor and control of 1:1 Redundancy or Standalone LGaN applications using the CLC-10 CEFD LGaN Controller (a preconfigured Two Technologies, Inc. TechTerm Handheld Terminal). The circular connector installs onto the Redundant Loop Cable 'J1' connector in 1:1 LGaN Redundant applications, or the 'J6 | COM 1' connector on a Standalone LGaN. The RJ-11 connector plugs directly into the CLC-10.

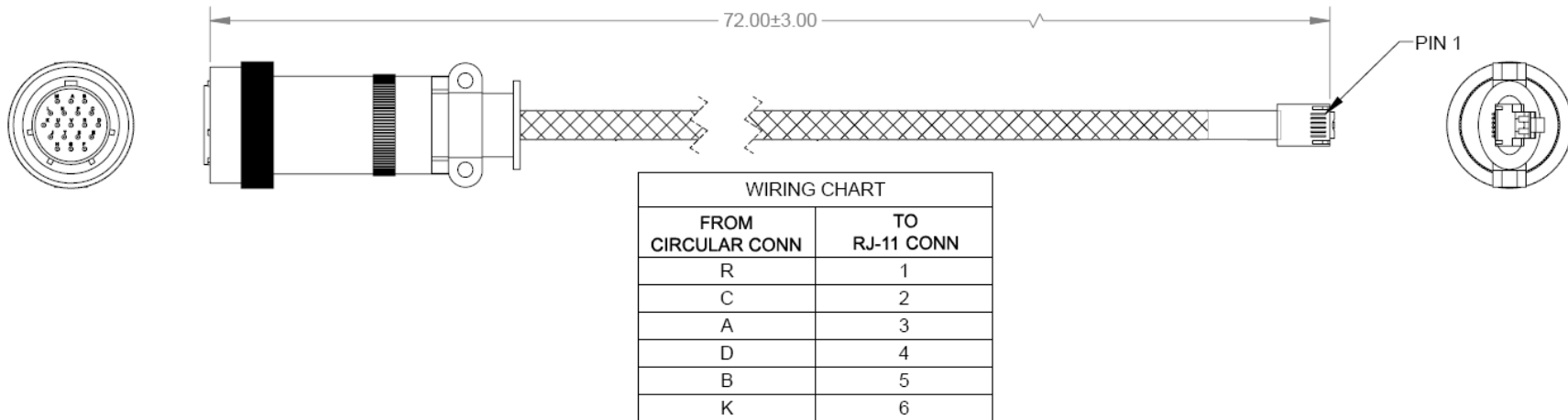
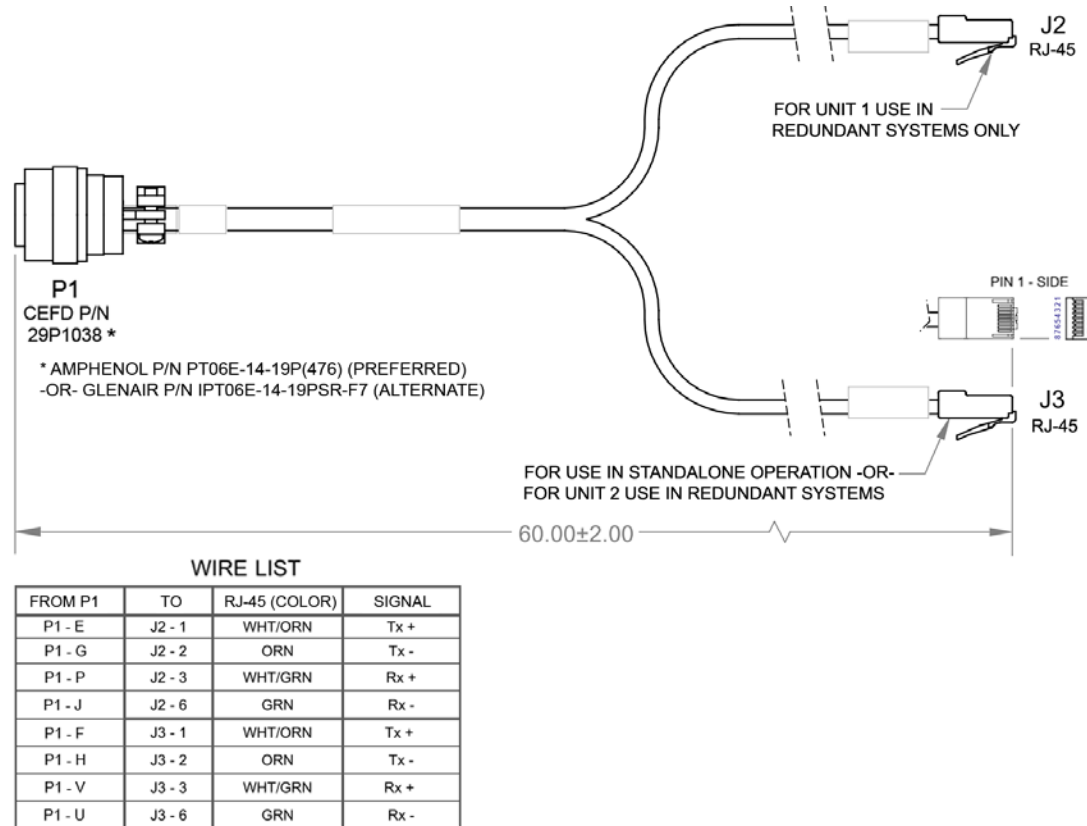

Figure A-1. Serial Interface Cable (CEFD P/N CA-0020526, part of KT-0020518)

## A.2.2 Ethernet Interface Cable

The CEFD Ethernet Utility Kit (CEFD P/N KT-0000203) includes the CA-0000352 Ethernet Interface Cable. This kit is optionally available to provide Ethernet-based M&C of Standalone LGaN applications using a Samsung NB30 Plus Netbook (LGaNnet). The 'P1' circular connector installs onto the 'J6 | COM 1' connector on a Standalone LGaN. Use the 'J2' and 'J3' RJ-45 connectors to either connect directly to the LGaNnet's Ethernet network jack for Standalone use.

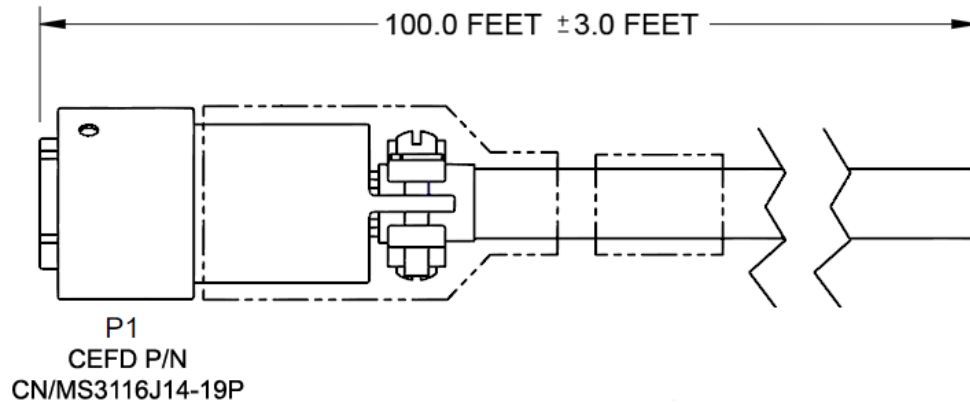

**Figure A-2. Ethernet Interface Cable (CEFD P/N CA-0000352, part of KT-0000203)**



### A.2.3 19-Pin COMMS Cable (100')

This cable connects between the designated data interface and the 'J6 | COM 1' port on a Standalone LGaN.



### WIRE LIST

PIN	COLOR	SIGNAL
A	RED/BRN	RS485_+RX
B	BRN/RED	RS485_-RX
C	WHT/BLU	RS485_+TX
D	BLU/WHT	RS485_-TX
E	WHT/ORN	ENET_TX+_UNIT1
F	RED/ORN	ENET_TX+_UNIT2
G	ORN/WHT	ENET_TX-_UNIT1
H	ORN/RED	ENET_TX-_UNIT2
J	GRN/WHT	ENET_RX-_UNIT1
K	GRY/RED	GND
L	WHT/BRN	UNIT1_OK
M	BRN/WHT	UNIT2_OK
N	RED/BLU	TX_SW_POS1_LOW
P	WHT/GRN	ENET_RX+_UNIT1
R	RED/GRY	+24V
S	GRY/WHT	AUX_MUTE_LOW
T	BLU/RED	SWITCH_COM
U	GRN/RED	ENET_RX-_UNIT2
V	RED/GRN	ENET_RX+_UNIT2

Figure A-3. COMMS Cable, 100' (CEFD P/N CA-0000318)

### A.2.4 19-Pin COMMS Cable (250')

This cable connects between the designated data interface and the 'J6 | COM 1' port on a Standalone LGaN.

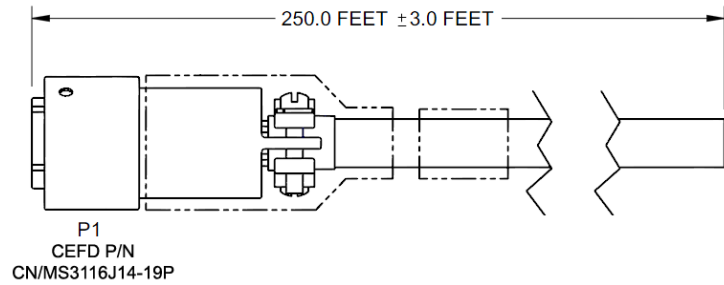

WIRE LIST

FROM	COLOR	LPOD / SPOD SINGLE UNIT	LPOD / SPOD REDUNDANT
P1-A	RED/BRN	RS485 +RX	RS485 +RX
P1-B	BRN/RED	RS485 -RX	RS485 -RX
P1-C	WHT/BLU	RS485 +TX	RS485 +TX
P1-D	BLU/WHT	RS485 -TX	RS485 -TX
P1-E	WHT/ORN	RS232 RD	10BASE-T TX+(B)
P1-F	RED/ORN	ETHERNET TX+	10BASE-T TX+(A)
P1-G	ORN/WHT	RS232 TD	10BASE-T TX-(B)
P1-H	ORN/RED	ETHERNET TX-	10BASE-T TX-(A)
P1-J	GRN/WHT	TX / RX SWITCH DRIVE 1 POS	10BASE-T TX-(B)
P1-K	GRY/RED	GROUND	GROUND
P1-L	WHT/BRN	SUM FAULT IN	CUST COMM UNIT A STATUS
P1-M	BRN/WHT	SUM FAULT OUT	CUST COMM UNIT B STATUS
P1-N	RED/BLU	TX SWITCH POS 1 IND	TX SWITCH POS 1 IND
P1-P	WHT/GRN	RX SWITCH POS 1 IND	10BASE-T TX+(B)
P1-R	RED/GRY	+24V	+24V
P1-S	GRY/WHT	SYSTEM MUTE CONTROL	SYSTEM MUTE
P1-T	BLU/RED	SWITCH COMMON	SWITCH COMMON
P1-U	GRN/RED	ETHERNET RX-	10BASE-T RX-(A)
P1-V	RED/GRN	ETHERNET RX+	10BASE-T RX+(A)

Figure A-4. COMMS Cable, 250' (CEFD P/N CA-0000543)

### A.3 RF Cables

FIG	CEFD CABLE P/N	DESCRIPTION	USED FOR:	REF App A FIG
Figure A-5	CA/3722-X	Type 'N' to Type 'N' 1/4" Helix Coaxial Cable (lengths vary)	LGaN Rx or Tx connections in Standalone LGaN applications.	A-3

### A.3.1 RF Cable (Type ‘N’)

Use this Type ‘N’ cable for the Rx or Tx connections in LGaN Standalone applications:

- For LGaN 100 W C-Band and X-Band applications – For Standalone use, the cable connects the unit’s ‘J2 | RF OUT’ port directly to your Rx signal destination.
- For all LGaN applications – For Standalone use, the cable connects directly from these LGaN interfaces to your Rx signal destination or Tx signal source.

PART NO.	DIM A
CA/3722	144.00 ± 4.00
CA/3722-1	48.00 ± 1.50
CA/3722-2	60.00 ± 2.00
CA/3722-3	90.00 ± 2.00
CA/3722-4	264.00 ± 4.00
CA/3722-5	288.00 ± 4.00
CA/3722-6	72.00 ± 2.00
CA/3722-7	240.00 ± 4.00
CA/3722-8	120.00 ± 4.00
CA/3722-9	180.00 ± 4.00
CA/3722-10	192.00 ± 12.00
CA/3722-11	108.00 ± 4.00

NOTE: CABLE MUST MEET VSWR 10.96-12.75 ≤ 1.40:1  
WITH INSERTION LOSS AS FOLLOWS:

FREQUENCY MHz	ATTENUATION db/100ft	ATTENUATION db/100 M	AVERAGE POWER kW
10000	21.8	71.5	0.054
12000	24.3	79.7	0.049
14000	26.7	86.3	0.044
16000	29.0	95.2	0.040

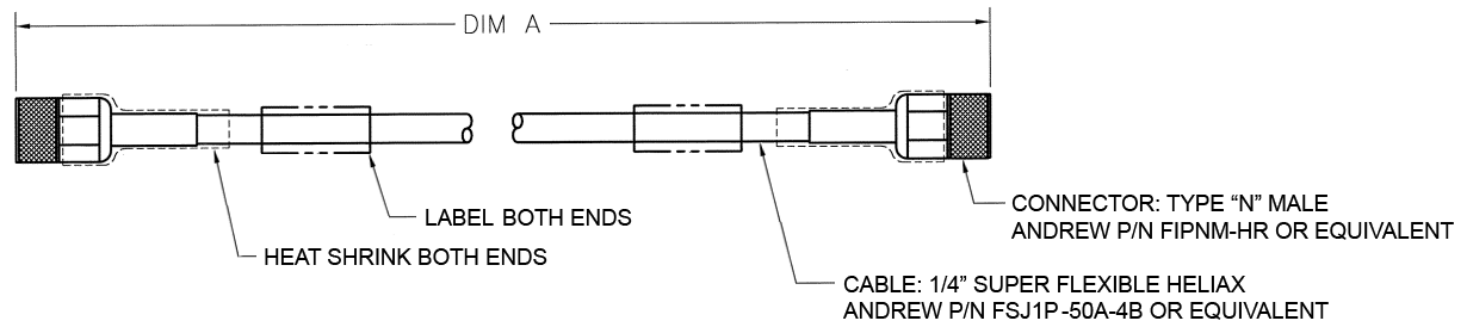

Figure A-5. 1/4" Heliax Coaxial Cable (CEFD P/N CA/3722-X)





---

2114 WEST 7TH STREET TEMPE ARIZONA 85281 USA  
480 • 333 • 2200 PHONE  
480 • 333 • 2161 FAX