



RAP-100

Remote Access Panel Installation and Operation Manual

Part Number MN/RAP100.IOM
Revision 1
December 8, 1999

Copyright © 1999 Comtech EF Data. All rights reserved. Printed in the USA. Comtech EF Data, 2114
West 7th Street, Tempe, Arizona 85281 USA, 480.333.2200, FAX: 480.333.2161

Errata A

Comtech EF Data Documentation Update

RAP-100

Remote Access Panel
Installation and Operation Manual
MN-RAP100.IOM REV 1

**Original Manual Part
Number/Rev:**

MN/RAP100.IOM Rev 1

**Errata Number/
PLM Document ID:**

ER-RAP100-EA1

PLM CO Number:

C-0029408

Comments:

The updated information will be in the next formal revision of the manual.

Change:

Added photographs to page 1-2

1.4 Getting Started:

After the interface cable between the RAP-100 and CSAT is built and installed, simply apply power for both units. The 'Comm. Link' LED on the front of the RAP-100 will be GREEN when the two units are communicating and RED when a problem exists. If the LED is RED go to the 'LINK' menu and select 'ESTABLISH'. Select the when queried 'RE-ESTABLISH COMM LINK?'. The RAP-100 will now attempt to communicate to the CSAT via the global address '0' at the 5 possible baud rates. Once communications have been established the RAP-100 will direct the CSAT to address 0001 and 9600 baud. If this does not resolve the problem first verify that the interface cable is correct then contact Comtech EFDData customer service.

1.5 Photographs



Figure 1-1 Front Panel



Figure 1-2 Cover

Customer Support

Contact the Comtech EFData Customer Support Department for:

- Product support or training
- Information on upgrading or returning a product
- Reporting comments or suggestions concerning manuals

A Customer Support representative may be reached at:

Comtech EFData
Attention: Customer Support Department
2114 West 7th Street
Tempe, Arizona 85281 USA

(480) 333-2200 (Main Comtech EFData Number)
(480) 333-4357 (Customer Support Desk)
(480) 333-2161 FAX

or, E-Mail can be sent to the Customer Support Department at:

service@comtechefdata.com

Contact us via the web at www.comtechefdata.com.

1. To return a Comtech EFData product (in-warranty and out-of-warranty) for repair or replacement:
2. Request a Return Material Authorization (RMA) number from the Comtech EFData Customer Support Department.
3. Be prepared to supply the Customer Support representative with the model number, serial number, and a description of the problem.
4. To ensure that the product is not damaged during shipping, pack the product in its original shipping carton/packaging.
5. Ship the product back to Comtech EFData. (Shipping charges should be prepaid.)

For more information regarding the warranty policies, see Warranty Policy, p. viii.

Table of Contents

Customer Support	ii
About this Manual	vii
Conventions and References.....	vii
Reporting Comments or Suggestions Concerning this Manual	vii
Warranty Policy	viii
Limitations of Warranty	viii
Exclusive Remedies.....	viii
Disclaimer	viii
CHAPTER 1. INTRODUCTION	1-1
1.1 Equipment Use:	1-1
1.2 Equipment Power:	1-1
1.3 CSAT Interface:	1-1
1.4 Getting Started:	1-2
CHAPTER 2. REDUNDANT CSAT CONTROL	2-1
2.1 RAP-100 Menus	2-3
2.1.1 VOLTAGES Selection	2-3
2.1.2 SWITCHES Selection:	2-3
2.1.3 MODE Selection:	2-4
2.1.4 ONLINE Selection:	2-4
CHAPTER 3. ODU OPERATION	3-1
3.1 Front Panel ODU Operation	3-1

3.2 MENU TREES..... 3-2

- 3.2.1 SELECT 3-2
- 3.2.2 ODU 3-2
- 3.2.3 (ODU,ENABLE) System Type 3-2
- 3.2.4 (ODU,ENABLE) 1:1 3-3
- 3.2.5 (ODU,ENABLE,1:1) RED BOX (Redundancy Controller Box) 3-3
- 3.2.6 (ODU,ENABLE,1:1,RED BOX) ONLINE 3-3
- 3.2.7 (ODU,ENABLE,1:1,RED BOX) MODE 3-3
- 3.2.8 (ODU,ENABLE,1:1,RED BOX) SWITCHES 3-4
- 3.2.9 (ODU,ENABLE,1:1,RED BOX) VOLTAGES 3-4
- 3.2.10 (ODU,ENABLE,1:1,CSAT#1) Selections (ODU,ENABLE,1:1,CSAT#2) Selections
(ODU,ENABLE,STAND-ALONE) Selections 3-4
- 3.2.11 (ODU,ENABLE,1:1,CSAT#1) CONFIG (Confiuration) (ODU,ENABLE,1:1,CSAT#2) CONFIG
(Confiuration) (ODU,ENABLE,STAND-ALONE) CONFIG (Confiuration) 3-4
- 3.2.12 (ODU,ENABLE,1:1,CSAT#1,CONFIG) TRANSMITTER (ODU,ENABLE,1:1,CSAT#2,CONFIG)
TRANSMITTER (ODU,ENABLE,STAND-ALONE,CONFIG) TRANSMITTER 3-4
- 3.2.13 (ODU,ENABLE,1:1,CSAT#1,CONFIG,TRANSMITTER) FREQUENCY
(ODU,ENABLE,1:1,CSAT#2,CONFIG,TRANSMITTER) FREQUENCY (ODU,ENABLE,STAND-
ALONE,CONFIG,TRANSMITTER) FREQUENCY 3-5
- 3.2.14 (ODU,ENABLE,1:1,CSAT#1,CONFIG,TRANSMITTER) ATTEN (Attenuation)
(ODU,ENABLE,1:1,CSAT#2,CONFIG,TRANSMITTER) ATTEN (Attenuation) (ODU,ENABLE,STAND-
ALONE,CONFIG,TRANSMITTER) ATTEN (Attenuation) 3-5
- 3.2.15 (ODU,ENABLE,1:1,CSAT#1,CONFIG,TRANSMITTER) AMPLIFIER
(ODU,ENABLE,1:1,CSAT#2,CONFIG,TRANSMITTER) AMPLIFIER (ODU,ENABLE,STAND-
ALONE,CONFIG,TRANSMITTER) AMPLIFIER 3-5
- 3.2.16 (ODU,ENABLE,1:1,CSAT#1,CONFIG,TRANSMITTER) MUTE
(ODU,ENABLE,1:1,CSAT#2,CONFIG,TRANSMITTER) MUTE (ODU,ENABLE,STAND-
ALONE,CONFIG,TRANSMITTER) MUTE 3-5
- 3.2.17 (ODU,ENABLE,1:1,CSAT#1,CONFIG,TRANSMITTER) SLOPE
(ODU,ENABLE,1:1,CSAT#2,CONFIG,TRANSMITTER) SLOPE (ODU,ENABLE,STAND-
ALONE,CONFIG,TRANSMITTER) SLOPE 3-6
- 3.2.18 (ODU,ENABLE,1:1,CSAT#1,CONFIG,TRANSMITTER,SLOPE) MANUAL
(ODU,ENABLE,1:1,CSAT#2,CONFIG,TRANSMITTER,SLOPE) MANUAL (ODU,ENABLE,STAND-
ALONE,CONFIG,TRANSMITTER,SLOPE) MANUAL 3-6
- 3.2.19 (ODU,ENABLE,1:1,CSAT#1,CONFIG) RECEIVER (ODU,ENABLE,1:1,CSAT#2,CONFIG)
RECEIVER (ODU,ENABLE,STAND-ALONE,CONFIG) RECEIVER 3-6
- 3.2.20 (ODU,ENABLE,1:1,CSAT#1,CONFIG,RECEIVER) FREQUENCY
(ODU,ENABLE,1:1,CSAT#2,CONFIG,RECEIVER) FREQUENCY (ODU,ENABLE,STAND-
ALONE,CONFIG,RECEIVER) FREQUENCY 3-6
- 3.2.21 (ODU,ENABLE,1:1,CSAT#1,CONFIG,RECEIVER) ATTEN (Attenuation)
(ODU,ENABLE,1:1,CSAT#2,CONFIG,RECEIVER) ATTEN (Attenuation) (ODU,ENABLE,STAND-
ALONE,CONFIG,RECEIVER) ATTEN (Attenuation) 3-7
- 3.2.22 (ODU,ENABLE,1:1,CSAT#1,CONFIG,RECEIVER) MUTE
(ODU,ENABLE,1:1,CSAT#2,CONFIG,RECEIVER) MUTE (ODU,ENABLE,STAND-
ALONE,CONFIG,RECEIVER) MUTE 3-7
- 3.2.23 (ODU,ENABLE,1:1,CSAT#1,CONFIG,RECEIVER) SLOPE
(ODU,ENABLE,1:1,CSAT#2,CONFIG,RECEIVER) SLOPE (ODU,ENABLE,STAND-
ALONE,CONFIG,RECEIVER) SLOPE 3-7
- 3.2.24 (ODU,ENABLE,1:1,CSAT#1,CONFIG,RECEIVER,SLOPE) MANUAL
(ODU,ENABLE,1:1,CSAT#2,CONFIG,RECEIVER,SLOPE) MANUAL (ODU,ENABLE,STAND-
ALONE,CONFIG,RECEIVER,SLOPE) MANUAL 3-7
- 3.2.25 (ODU,ENABLE,1:1,CSAT#1,CONFIG,RECEIVER) LNA
(ODU,ENABLE,1:1,CSAT#2,CONFIG,RECEIVER) LNA (ODU,ENABLE,STAND-
ALONE,CONFIG,RECEIVER) LNA 3-8

3.2.26 (ODU,ENABLE,1:1,CSAT#1,CONFIG,RECEIVER,LNA) STATE
(ODU,ENABLE,1:1,CSAT#2,CONFIG,RECEIVER,LNA) STATE (ODU,ENABLE,STAND-
ALONE,CONFIG,RECEIVER,LNA) STATE..... 3-8

3.2.27 (ODU,ENABLE,1:1,CSAT#1,CONFIG,RECEIVER,LNA) CAL (Calibrate)
(ODU,ENABLE,1:1,CSAT#2,CONFIG,RECEIVER,LNA) CAL (Calibrate) (ODU,ENABLE,STAND-
ALONE,CONFIG,RECEIVER,LNA) CAL (Calibrate)..... 3-8

3.2.28 (ODU,ENABLE,1:1,CSAT#1,CONFIG,RECEIVER,LNA) CURR-WINDOW
(ODU,ENABLE,1:1,CSAT#2,CONFIG,RECEIVER,LNA) CURR-WINDOW (ODU,ENABLE,STAND-
ALONE,CONFIG,RECEIVER,LNA) CURR-WINDOW 3-8

3.2.29 (ODU,ENABLE,1:1,CSAT#1,CONFIG,RECEIVER,LNA) FAULT-LOGIC
(ODU,ENABLE,1:1,CSAT#2,CONFIG,RECEIVER,LNA) FAULT-LOGIC (ODU,ENABLE,STAND-
ALONE,CONFIG,RECEIVER,LNA) FAULT-LOGIC..... 3-9

3.2.30 (ODU,ENABLE,1:1,CSAT#1,CONFIG) MISCELLANEOUS
(ODU,ENABLE,1:1,CSAT#2,CONFIG) MISCELLANEOUS (ODU,ENABLE,STAND-ALONE,CONFIG)
MISCELLANEOUS 3-9

3.2.31 (ODU,ENABLE,1:1,CSAT#1,CONFIG,MISCELLANEOUS) COLD-START
(ODU,ENABLE,1:1,CSAT#2,CONFIG,MISCELLANEOUS) COLD-START (ODU,ENABLE,STAND-
ALONE,CONFIG,MISCELLANEOUS) COLD-START 3-9

3.2.32 (ODU,ENABLE,1:1,CSAT#1,CONFIG,MISCELLANEOUS) AFR(Auto Flt Rec)
(ODU,ENABLE,1:1,CSAT#2,CONFIG,MISCELLANEOUS) AFR(Auto Flt Rec) (ODU,ENABLE,STAND-
ALONE,CONFIG,MISCELLANEOUS) AFR(Auto Flt Rec) 3-9

3.2.33 (ODU,ENABLE,1:1,CSAT#1,CONFIG,MISCELLANEOUS) XREF(Ext Ref)
(ODU,ENABLE,1:1,CSAT#2,CONFIG,MISCELLANEOUS) XREF(Ext Ref) (ODU,ENABLE,STAND-
ALONE,CONFIG,MISCELLANEOUS) XREF(Ext Ref) 3-10

3.2.34 (ODU,ENABLE,1:1,CSAT#1,CONFIG,MISCELLANEOUS) REF-ADJUST
(ODU,ENABLE,1:1,CSAT#2,CONFIG,MISCELLANEOUS) REF-ADJUST (ODU,ENABLE,STAND-
ALONE,CONFIG,MISCELLANEOUS) REF-ADJUST 3-10

3.2.35 (ODU,ENABLE,1:1,CSAT#1,CONFIG,MISCELLANEOUS) RTC
(ODU,ENABLE,1:1,CSAT#2,CONFIG,MISCELLANEOUS) RTC (ODU,ENABLE,STAND-
ALONE,CONFIG,MISCELLANEOUS) RTC..... 3-10

3.2.36 (ODU,ENABLE,1:1,CSAT#1) INFO (Information) (ODU,ENABLE,1:1,CSAT#2) INFO
(Information) (ODU,ENABLE,STAND-ALONE) INFO (Information)..... 3-10

3.2.37 (ODU,ENABLE,1:1,CSAT#1,INFO) MODEL (ODU,ENABLE,1:1,CSAT#2,INFO) MODEL
(ODU,ENABLE,STAND-ALONE,INFO) MODEL..... 3-11

3.2.38 (ODU,ENABLE,1:1,CSAT#1,INFO) TRANSMITTER (ODU,ENABLE,1:1,CSAT#2,INFO)
TRANSMITTER (ODU,ENABLE,STAND-ALONE,INFO) TRANSMITTER 3-11

3.2.39 (ODU,ENABLE,1:1,CSAT#1,INFO) RECEIVER (ODU,ENABLE,1:1,CSAT#2,INFO) RECEIVER
(ODU,ENABLE,STAND-ALONE,INFO) RECEIVER 3-11

3.2.40 (ODU,ENABLE,1:1,CSAT#1,INFO) MISC (ODU,ENABLE,1:1,CSAT#2,INFO) MISC
(ODU,ENABLE,STAND-ALONE,INFO) MISC 3-11

3.2.41 (ODU,ENABLE,1:1,CSAT#1,INFO) LNA (ODU,ENABLE,1:1,CSAT#2,INFO) LNA
(ODU,ENABLE,STAND-ALONE,INFO) LNA..... 3-11

3.2.42 (ODU,ENABLE,1:1,CSAT#1) MONITOR (ODU,ENABLE,1:1,CSAT#2) MONITOR
(ODU,ENABLE,STAND-ALONE) MONITOR..... 3-12

3.2.43 (ODU,ENABLE,1:1,CSAT#1,MONITOR) TX (Transmitter)
(ODU,ENABLE,1:1,CSAT#2,MONITOR) TX (Transmitter) (ODU,ENABLE,STAND-ALONE,MONITOR)
TX (Transmitter)..... 3-12

3.2.44 (ODU,ENABLE,1:1,CSAT#1,MONITOR) RX (Receiver) (ODU,ENABLE,1:1,CSAT#2,MONITOR)
RX (Receiver) (ODU,ENABLE,STAND-ALONE,MONITOR) RX (Receiver)..... 3-12

3.2.45 (ODU,ENABLE,1:1,CSAT#1,MONITOR) MISC (ODU,ENABLE,1:1,CSAT#2,MONITOR) MISC
(ODU,ENABLE,STAND-ALONE,MONITOR) MISC 3-12

3.2.46 (ODU,ENABLE,1:1,CSAT#1,MONITOR) PWR SUPP1 (ODU,ENABLE,1:1,CSAT#2,MONITOR)
PWR SUPP1 (ODU,ENABLE,STAND-ALONE,MONITOR) PWR SUPP1 3-12

3.2.47 (ODU,ENABLE,1:1,CSAT#1,MONITOR) PWR SUPP2 (ODU,ENABLE,1:1,CSAT#2,MONITOR)
PWR SUPP2 (ODU,ENABLE,STAND-ALONE,MONITOR) PWR SUPP2 3-13

3.2.48 (ODU,ENABLE,1:1,CSAT#1) ALARMS (ODU,ENABLE,1:1,CSAT#2) ALARMS
 (ODU,ENABLE,STAND-ALONE) ALARMS..... 3-13

3.2.49 (ODU,ENABLE,1:1,CSAT#1,ALARMS) CURRENT (ODU,ENABLE,1:1,CSAT#2,ALARMS)
 CURRENT (ODU,ENABLE,STAND-ALONE,ALARMS) CURRENT..... 3-13

3.2.50 (ODU,ENABLE,1:1,CSAT#1,ALARMS) STORED (ODU,ENABLE,1:1,CSAT#2,ALARMS)
 STORED (ODU,ENABLE,STAND-ALONE,ALARMS) STORED..... 3-13

3.2.51 (ODU,ENABLE,1:1,CSAT#1,ALARMS,STORED) VIEW
 (ODU,ENABLE,1:1,CSAT#2,ALARMS,STORED) VIEW (ODU,ENABLE,STAND-
 ALONE,ALARMS,STORED) VIEW 3-14

3.2.52 (ODU,ENABLE,1:1,CSAT#1,ALARMS,STORED) CLEAR ALL
 (ODU,ENABLE,1:1,CSAT#2,ALARMS,STORED) CLEAR ALL (ODU,ENABLE,STAND-
 ALONE,ALARMS,STORED) CLEAR ALL..... 3-14

About this Manual

This manual provides installation and operation information for the Comtech EFData RAP-100 Remote Access Panel. This is a technical document intended for earth station engineers, technicians, and operators responsible for the operation and maintenance of the RAP-100.

Conventions and References

Cautions and Warnings



CAUTION indicates a hazardous situation that, if not avoided, may result in minor or moderate injury. CAUTION may also be used to indicate other unsafe practices or risks of property damage.



WARNING indicates a potentially hazardous situation that, if not avoided, could result in death or serious injury.

Metric Conversion

Metric conversion information is located on the inside back cover of this manual. This information is provided to assist the operator in cross-referencing English to Metric conversions.

Trademarks

Other product names mentioned in this manual may be trademarks or registered trademarks of their respective companies and are hereby acknowledged.

Reporting Comments or Suggestions Concerning this Manual

Comments and suggestions regarding the content and design of this manual will be appreciated. To submit comments, please contact the Comtech EFData Customer Support Department.

Warranty Policy

This Comtech EFData product is warranted against defects in material and workmanship for a period of two years from the date of shipment. During the warranty period, Comtech EFData will, at its option, repair or replace products that prove to be defective.

For equipment under warranty, the customer is responsible for freight to Comtech EFData and all related custom, taxes, tariffs, insurance, etc. Comtech EFData is responsible for the freight charges **only** for return of the equipment from the factory to the customer. Comtech EFData will return the equipment by the same method (i.e., Air, Express, Surface) as the equipment was sent to Comtech EFData.

Limitations of Warranty

The foregoing warranty shall not apply to defects resulting from improper installation or maintenance, abuse, unauthorized modification, or operation outside of environmental specifications for the product, or, for damages that occur due to improper repackaging of equipment for return to Comtech EFData.

No other warranty is expressed or implied. Comtech EFData specifically disclaims the implied warranties of merchantability and fitness for particular purpose.

Exclusive Remedies

The remedies provided herein are the buyer's sole and exclusive remedies. Comtech EFData shall not be liable for any direct, indirect, special, incidental, or consequential damages, whether based on contract, tort, or any other legal theory.

Disclaimer

Comtech EFData has reviewed this manual thoroughly in order that it will be an easy-to-use guide to your equipment. All statements, technical information, and recommendations in this manual and in any guides or related documents are believed reliable, but the accuracy and completeness thereof are not guaranteed or warranted, and they are not intended to be, nor should they be understood to be, representations or warranties concerning the products described. Further, Comtech EFData reserves the right to make changes in the specifications of the products described in this manual at any time without notice and without obligation to notify any person of such changes.

If you have any questions regarding your equipment or the information in this manual, please contact the Comtech EFData Customer Support Department.

1 Chapter 1. INTRODUCTION

1.1 Equipment Use:

The RAP-100 is designed to provide front console monitoring and control of a single Comtech EFData CSAT Outdoor Transceiver. The RAP-100 is packaged in a chassis suitable for mounting in standard 19 inch Telecommunication equipment racks.

1.2 Equipment Power:

The equipment is rated for operation over the range 100 – 240 volts AC. It has a maximum power consumption of 15 watts.

1.3 CSAT Interface:

The RAP-100 is designed to interface to Comtech EFData's CSAT via an RS-485 interface. The pin-out for the connection between the RAP-100 and the CSAT is shown in the table below:

Signal Name	RAP-100 pin	CSAT pin
RS-485 Rx+	8	A
RS-485 Rx-	9	B
RS-485 Tx+	6	C
RS-485 Tx-	7	D
Signal Ground	1	U

1.4 Getting Started:

After the interface cable between the RAP-100 and CSAT is built and installed, simply apply power for both units. The 'Comm. Link' LED on the front of the RAP-100 will be GREEN when the two units are communicating and RED when a problem exists. If the LED is RED go to the 'LINK' menu and select 'ESTABLISH'. Select the when queried 'RE-ESTABLISH COMM LINK?'. The RAP-100 will now attempt to communicate to the CSAT via the global address '0' at the 5 possible baud rates. Once communications have been established the RAP-100 will direct the CSAT to address 0001 and 9600 baud. If this does not resolve the problem first verify that the interface cable is correct then contact Comtech EFData customer service.

4/1/1999

2 Chapter 2. REDUNDANT CSAT CONTROL

The RAP-100 (Remote Access Panel) is designed to provide a simple 'Indoor' interface to Comtech EFData's 'Outdoor' CSAT terminals. RAP-100's with software version 1.03 (or later) installed also support direct communications with 2 CSATs and the Redundancy Controller Box in a redundancy configuration.

The figure below provides a functional block diagram of a 1:1 Redundant CSAT system with a RAP-100 used as the system monitor and control device.

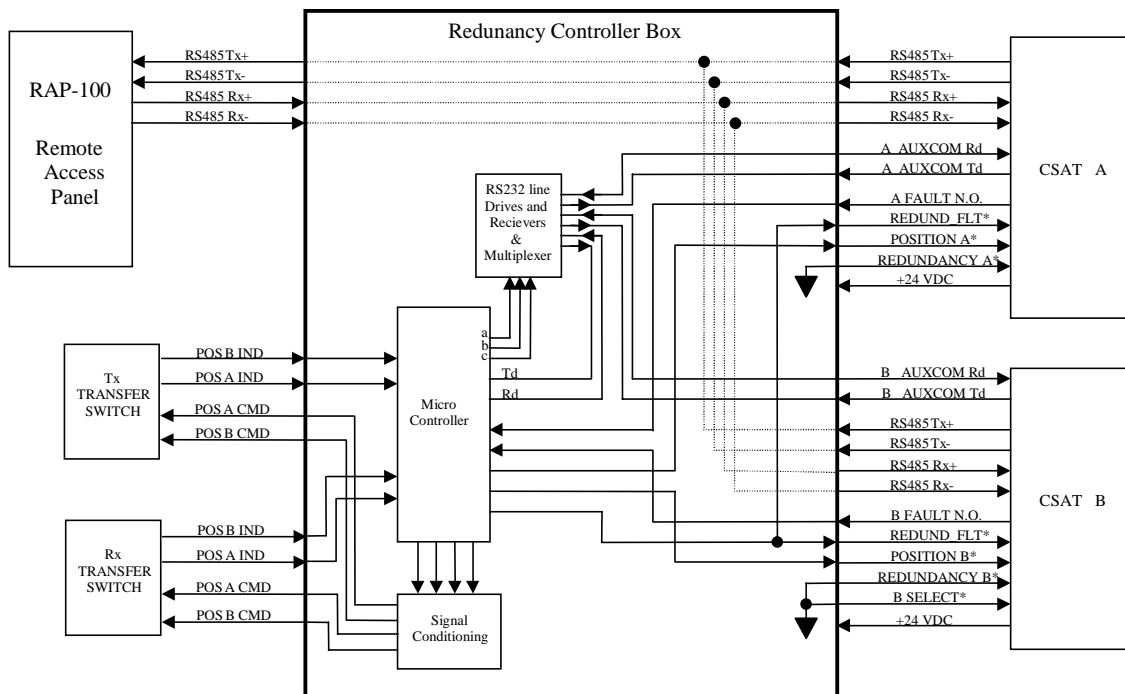

There are a few important points to be made about this system architecture. First, the Redundancy Controller Box is in complete control of the transfer switches (both Tx and Rx) when the system is in AUTO mode. This means that the Redundancy Controller Box is always monitoring the status of both CSATs via their Summary Fault Relays and will change the position of the switches if the ONLINE unit fails.

If the OFFLINE unit is also failed, the Redundancy Controller Box will not change the switch position.

The second point is the operator can **force** a change in the switch position via either a serial command to the Redundancy Controller Box or by shorting the appropriate pins on the interface connector. Again this assumes that both unit are non-failed.

The third point is that if the operator commands the Redundancy Controller Box to MANUAL mode, subsequent 'Switch Position' commands will always cause the transfer switches to change position independent of the status of the CSATs (failed or non-failed).

The fourth point is that when the Redundancy Controller Box is in MANUAL mode it does **not** automatically switch the position of the Tx and Rx transfer switches when the ONLINE unit fails.

The final important point to be made is that the RAP-100 monitors and controls the redundant system using only serial commands sent via the 4-wire RS-485 interface.

2.1 RAP-100 Menus

After connecting the RAP-100 to the Redundancy Controller Box and turning power ON for all of the components in the system the “COMM LINK” LED on the RAP-100 should be GREEN. If this LED is RED, verify that all interface cables between the two CSATs and the Redundancy Controller Box as well as the interface cable between the RAP-100 and the Redundancy Controller Box are properly made. If the problem persists contact Comtech EFData Customer Support.

The second display window that you will encounter is the ‘SYSTEM TYPE’ menu selection. The choices are ‘STAND-ALONE’ and ‘1:1’. Use the Right or Left Arrow keys to select ‘1:1’ then press the Enter key. This will take you to the ‘MONITOR/CONTROL’ menu selection. There are three choices here; ‘CSAT#1’, ‘CSAT#2’ and ‘RED BOX’. Selecting either ‘CSAT#1’ or ‘CSAT#2’ will allow you to configure and monitor each of the individual CSATs. Selecting ‘RED BOX’ will allow you to monitor and control the Redundancy Controller Box and the transfer switches. This is the selection that we will discuss in this paper.

Use the Right or Left Arrow keys to select ‘RED BOX’ then press the Enter Key. This will take you to the ‘REDUNDANCY BOX’ menu selection. There are four (4) sub-windows in this menu branch; ‘ONLINE’, ‘MODE’, ‘SWITCHES’, and ‘VOLTAGES’. The paragraphs below explain each of these sub-windows in detail.

2.1.1 VOLTAGES Selection

This selection allows you to view the voltage of both the 5V and 12V regulators in the Redundancy Controller Box. This window is provided primarily to assist in trouble shooting problems with a redundant system. The voltages displayed should be within +/- 10% of their respective nominal values.

2.1.2 SWITCHES Selection:

This selection allows you to view the status of both the ‘Tx’ and the ‘Rx’ transfer switches. An ‘OK’ or ‘FT’ indication is provided for each switch. ‘OK’ indicates that the respective switch is in the position last commanded via the Redundancy Controller Box. ‘FT’ indicates that the respective switch is **not** in the position last commanded via the Redundancy Controller Box. If a ‘FT’ indication is displayed you should first verify that the interface cable between the transfer switch and the Redundancy Controller Box is properly connected. Second you should verify that the voltages in the Redundancy Controller Box using the VOLTAGES menu item. Thirdly, you should command the Redundancy Controller Box to MANUAL mode (as described below) and toggle the switch position twice. If these steps do not fix the problem, contact Comtech EFData Customer Support.

2.1.3 MODE Selection:

This selection allows you to view and/or change the operating mode of the Redundancy Controller Box. If the cursor is on 'AUTO' the box is in Auto Mode. If the cursor is on 'MANUAL' the box is in Manual Mode. To change the operating mode, use the Right or Left Arrow keys to select the new mode then press the Enter key. (Note: you must always press the Enter key after making any change via any of the Arrow keys)

2.1.4 ONLINE Selection:

This selection allows you to view and/or change the position of the Tx and Rx transfer switches thus controlling the ONLINE/OFFLINE status of the two CSATs. If the cursor is on 'CSAT#1' then CSAT#1 is ONLINE and CSAT#2 is OFFLINE. If the cursor is on 'CSAT#2' then CSAT#1 is OFFLINE and CSAT#2 is ONLINE. To change the position of the transfer switches use the Right or Left Arrow keys to select the other CSAT (OFFLINE CSAT) and then press the Enter Key. Within 4 or 5 seconds both the Tx and Rx transfer switches should change positions. As explained previously, if the operating mode is AUTO and the OFFLINE unit is failed no change will occur. By placing the Redundancy Controller Box into MANUAL mode you can force the transfer switches to change position independent of the state of the two CSATs.

3 Chapter 3. ODU OPERATION

3.1 Front Panel ODU Operation

The user can fully control and monitor the operation of Comtech EFData's ODU from the front panel, using the keypad and display of either a CDM550 or CDM550T modem. Nested menus display all available options and prompt the user for required actions.

The display has two lines each of 24 characters. On most menu screens, a flashing ***solid block cursor*** blinks once per second to indicate the currently selected item, digit, or field. Where this solid block cursor would obscure the item being edited (for example, a numeric field) the cursor will automatically change to an ***underline cursor***.

The keypad has six keys, the functions of which are described below:

RIGHT ARROW	Moves the cursor to the right, when it is displayed
LEFT ARROW	Moves the cursor to the left, when it is displayed
UP ARROW	Used for editing the value at the current cursor position, if appropriate. If this is a numeric field, this will increment the value.
DOWN ARROW	Used for editing the value at the current cursor position, if appropriate. If this is a numeric field, this will decrement the value.
ENTER (ENT)	Used to accept an edited entry. Most menus prompt the user to press this key, by displaying the text (<i>PRESS ENTER</i>), (<i>ENTER</i>) or (<i>ENT</i>). This results in the entry being accepted, and the user is then returned to the previous menu.
CLEAR (CLR)	Used to escape from the current operation and return to the previous menu.

IMPORTANT NOTE: The keypad has an ***auto-repeat*** feature. If a key is held down for more than 1 second, the key action will repeat, automatically, at the rate of 15 keystrokes per second. This is particularly useful when editing numeric fields, with many digits, such as frequency or data rate.

3.2 MENU TREES

3.2.1 SELECT

```
SELECT: CONFIG TEST INFO
MONIT STORE/LD UTIL ODU
```

The user is presented with the following choices:

CONFIG	(Configuration) This menu branch permits the user to fully configure the unit.
TEST	This menu branch permits the user invoke one of several test modes (loopbacks, for example).
INFO	(Information) This menu branch permits the user to view information on the unit, without having to go into configuration screens.
MONIT	(Monitor) This menu branch permits the user to monitor the alarm status of the unit, to view the log of stored events, and to display the Receive Parameters screen.
STORE/LD	(Store/Load) This menu branch permits the user to store and to retrieve up to 10 different modem configurations.
UTIL	(Utility) This menu branch permits the user to perform miscellaneous functions, such as setting the Real-time clock, adjusting the display brightness, etc.
ODU	(Outdoor Unit) This permits the user to monitor and control a Comtech EFData RF Transceiver, if connected.

The first six items are covered in the existing modem manuals. The ODU item is now described in detail.

3.2.2 ODU

```
TRANSCEIVER CONTROL:
DISABLE ENABLE (ENTER)
```

DISABLE This menu item turns OFF the FSK link to the ODU.

ENABLE This menu item turns ON the FSK link to the ODU.

3.2.3 (ODU,ENABLE) System Type

```
SELECT ODU SYSTEM TYPE:
STAND-ALONE 1:1
```

The STAND-ALONE items should be selected when the Modem is linked via the Rx IF cable to a single Comtech EFData ODU. The 1:1 items should be selected when the Modem is linked to a redundant ODU system via connection between the Rx IF and the ODU Redundancy Controller Box.

3.2.4 (ODU,ENABLE) 1:1

```
MONITOR/CONTROL:  CSAT#1
                   CSAT#2  RED BOX
```

The user is prompted to select CSAT#1, CSAT#2 or the RED BOX as the device to be monitored. The first to selection will allow the user to monitor and/or control the configuration of the two individual ODU's. The third item, RED BOX, will allow the user to monitor the current state of the ODU Redundancy Controller Box as well as to change the current ONLINE/OFFLINE state of each ODU.

3.2.5 (ODU,ENABLE,1:1) RED BOX (Redundancy Controller Box)

```
REDUNDANCY BOX:  ONLINE
MODE  SWITCHES  VOLTAGES
```

The user is prompted to select from 1 of 4 items.

3.2.6 (ODU,ENABLE,1:1,RED BOX) ONLINE

```
ONLINE UNIT:
CSAT#1      CSAT#2
```

The cursor will be flashing under either CSAT#1 or CSAT#2. This is the indication of the currently ONLINE unit. If the user desires to change the ONLINE unit the LEFT/RIGHT arrow keys are used to move the cursor position and then the ENTER key must be depressed.

NOTE: If the ODU Redundancy system is in AUTO mode, a 'forced switch-over' can only occur if the currently OFFLINE unit is fault-free.

3.2.7 (ODU,ENABLE,1:1,RED BOX) MODE

```
OPERATING MODE:
AUTO          MANUAL
```

The cursor will be flashing under either AUTO or MANUAL. This is the indication of the current operating mode of the 1:1 ODU system. If the user desires to change the operating mode of the 1:1 system, the LEFT/RIGHT arrow keys are used to move the cursor position and then the ENTER key must be depressed.

3.2.8 (ODU,ENABLE,1:1,RED BOX) SWITCHES

```

WAVEGUIDE SWITCH STATUS:
TX=OK      RX=OK
    
```

This menu item provides the status of both the Tx and Rx Waveguide transfer switches. If either switch is reporting an ambiguity from the commanded position the “OK” will change to “FT”. This indicates a switch fault.

3.2.9 (ODU,ENABLE,1:1,RED BOX) VOLTAGES

```

REDUNDANCY BOX VOLTAGES:
5V= X.X    12V=XX.X
    
```

This menu item provides monitor of the voltages inside the Redundancy Controller Box. This is provided to assist in trouble-shooting system problems.

**3.2.10 (ODU,ENABLE,1:1,CSAT#1) Selections
(ODU,ENABLE,1:1,CSAT#2) Selections
(ODU,ENABLE,STAND-ALONE) Selections**

```

ODU SELECT: CONFIG INFO
MONITOR ALARMS (ENTER)
    
```

The user is prompted from 1 of 4 sub-menu branches using the LEFT/RIGHT arrow keys, then press ENTER.

**3.2.11 (ODU,ENABLE,1:1,CSAT#1) CONFIG (Confiation)
(ODU,ENABLE,1:1,CSAT#2) CONFIG (Confiation)
(ODU,ENABLE,STAND-ALONE) CONFIG (Confiation)**

```

ODU CONFIG: TRANSMITTER
RECEIVER MISCELLANEOUS
    
```

The user uses this menu item to select either the “Transmitter configuration branch”, “Receiver configuration branch” or “Miscellaneous configuration branch”. Use the LEFT/RIGHT arrow keys, then press ENTER.

**3.2.12 (ODU,ENABLE,1:1,CSAT#1,CONFIG) TRANSMITTER
(ODU,ENABLE,1:1,CSAT#2,CONFIG) TRANSMITTER
(ODU,ENABLE,STAND-ALONE,CONFIG) TRANSMITTER**

```

ODU TX: FREQUENCY ATTEN
AMPLIFIER MUTE SLOPE
    
```

This menu item is used to select which ODU Transmitter parameter is to be modified. Use the LEFT/RIGHT arrow keys, then press ENTER.

- | | | |
|---------------|--|--|
| 3.2.13 | (ODU,ENABLE,1:1,CSAT#1,CONFIG,TRANSMITTER)
(ODU,ENABLE,1:1,CSAT#2,CONFIG,TRANSMITTER)
(ODU,ENABLE,STAND-ALONE,CONFIG,TRANSMITTER) | FREQUENCY
FREQUENCY
FREQUENCY |
|---------------|--|--|

```

EDIT ODU TX FREQUENCY:
5912.5 MHz (PRESS ENT)
```

The user is prompted to edit the transmit frequency. This is accomplished by selecting the digit to be edited, using the LEFT/RIGHT arrow keys. The value of the digit is then changed using the UP/DOWN arrow keys. The user then press ENTER.

- | | | |
|---------------|--|--|
| 3.2.14 | (ODU,ENABLE,1:1,CSAT#1,CONFIG,TRANSMITTER)
(ODU,ENABLE,1:1,CSAT#2,CONFIG,TRANSMITTER)
(ODU,ENABLE,STAND-ALONE,CONFIG,TRANSMITTER) | ATTEN (Attenuation)
ATTEN (Attenuation)
ATTEN (Attenuation) |
|---------------|--|--|

```

EDIT ODU TX ATTENUATION:
15.00 dB (PRESS ENTER)
```

The user is prompted to edit the transmit attenuation. This is accomplished by selecting the digit to be edited, using the LEFT/RIGHT arrow keys. The value of the digit is then changed using the UP/DOWN arrow keys. The user then presses ENTER.

- | | | |
|---------------|--|--|
| 3.2.15 | (ODU,ENABLE,1:1,CSAT#1,CONFIG,TRANSMITTER)
(ODU,ENABLE,1:1,CSAT#2,CONFIG,TRANSMITTER)
(ODU,ENABLE,STAND-ALONE,CONFIG,TRANSMITTER) | AMPLIFIER
AMPLIFIER
AMPLIFIER |
|---------------|--|--|

```

SELECT ODU TX AMP STATE:
ON OFF (PRESS ENTER)
```

The user is prompted to select either ON or OFF, using the LEFT/RIGHT arrow keys, then to press ENTER.

- | | | |
|---------------|--|---|
| 3.2.16 | (ODU,ENABLE,1:1,CSAT#1,CONFIG,TRANSMITTER)
(ODU,ENABLE,1:1,CSAT#2,CONFIG,TRANSMITTER)
(ODU,ENABLE,STAND-ALONE,CONFIG,TRANSMITTER) | MUTE
MUTE
MUTE |
|---------------|--|---|

```

SELECT TX MUTE STATE:
MUTED UNMUTED (ENTER)
```

The user is prompted to select either MUTED or UNMUTED, using the LEFT/RIGHT arrow keys, then to press ENTER.

- 3.2.17 (ODU,ENABLE,1:1,CSAT#1,CONFIG,TRANSMITTER) SLOPE
- (ODU,ENABLE,1:1,CSAT#2,CONFIG,TRANSMITTER) SLOPE
- (ODU,ENABLE,STAND-ALONE,CONFIG,TRANSMITTER) SLOPE

```
SELECT TX SLOPE MODE :
CALIBRATED  MANUAL  ( ENT )
```

The user is prompted to select either CALIBRATED or MANUAL, using the LEFT/RIGHT arrow keys, then to press ENTER.

- 3.2.18 (ODU,ENABLE,1:1,CSAT#1,CONFIG,TRANSMITTER,SLOPE) MANUAL
- (ODU,ENABLE,1:1,CSAT#2,CONFIG,TRANSMITTER,SLOPE) MANUAL
- (ODU,ENABLE,STAND-ALONE,CONFIG,TRANSMITTER,SLOPE) MANUAL

```
EDIT ODU TX SLOPE :
0.0      ( PRESS ENTER )
```

If MANUAL mode is selected, the user is prompted to edit the transmit slope setting. This is accomplished using the UP/DOWN arrow keys. The user then presses ENTER.

- 3.2.19 (ODU,ENABLE,1:1,CSAT#1,CONFIG) RECEIVER
- (ODU,ENABLE,1:1,CSAT#2,CONFIG) RECEIVER
- (ODU,ENABLE,STAND-ALONE,CONFIG) RECEIVER

```
ODU RX: FREQUENCY  ATTEN
MUTE  SLOPE  LNA
```

This menu item is used to select which ODU Receiver parameter is to be modified. Use the LEFT/RIGHT arrow keys, then press ENTER.

- 3.2.20 (ODU,ENABLE,1:1,CSAT#1,CONFIG,RECEIVER) FREQUENCY
- (ODU,ENABLE,1:1,CSAT#2,CONFIG,RECEIVER) FREQUENCY
- (ODU,ENABLE,STAND-ALONE,CONFIG,RECEIVER) FREQUENCY

```
EDIT ODU RX FREQUENCY :
3912.5 MHz  ( PRESS ENT )
```

The user is prompted to edit the receive frequency. This is accomplished by selecting the digit to be edited, using the LEFT/RIGHT arrow keys. The value of the digit is then changed using the UP/DOWN arrow keys. The user then press ENTER.

- 3.2.21 (ODU,ENABLE,1:1,CSAT#1,CONFIG,RECEIVER) ATTEN (Attenuation)
- (ODU,ENABLE,1:1,CSAT#2,CONFIG,RECEIVER) ATTEN (Attenuation)
- (ODU,ENABLE,STAND-ALONE,CONFIG,RECEIVER) ATTEN (Attenuation)

```
EDIT ODU RX ATTENUATION:
15.00 dB (PRESS ENTER)
```

The user is prompted to edit the receive attenuation. This is accomplished by selecting the digit to be edited, using the LEFT/RIGHT arrow keys. The value of the digit is then changed using the UP/DOWN arrow keys. The user then presses ENTER.

- 3.2.22 (ODU,ENABLE,1:1,CSAT#1,CONFIG,RECEIVER) MUTE
- (ODU,ENABLE,1:1,CSAT#2,CONFIG,RECEIVER) MUTE
- (ODU,ENABLE,STAND-ALONE,CONFIG,RECEIVER) MUTE

```
SELECT RX MUTE STATE:
MUTED UNMUTED (ENTER)
```

The user is prompted to select either MUTED or UNMUTED, using the LEFT/RIGHT arrow keys, then to press ENTER.

- 3.2.23 (ODU,ENABLE,1:1,CSAT#1,CONFIG,RECEIVER) SLOPE
- (ODU,ENABLE,1:1,CSAT#2,CONFIG,RECEIVER) SLOPE
- (ODU,ENABLE,STAND-ALONE,CONFIG,RECEIVER) SLOPE

```
SELECT RX SLOPE MODE:
CALIBRATED MANUAL (ENT)
```

The user is prompted to select either CALIBRATED or MANUAL, using the LEFT/RIGHT arrow keys, then to press ENTER.

- 3.2.24 (ODU,ENABLE,1:1,CSAT#1,CONFIG,RECEIVER,SLOPE) MANUAL
- (ODU,ENABLE,1:1,CSAT#2,CONFIG,RECEIVER,SLOPE) MANUAL
- (ODU,ENABLE,STAND-ALONE,CONFIG,RECEIVER,SLOPE) MANUAL

```
EDIT ODU RX SLOPE:
0.0 (PRESS ENTER)
```

If MANUAL mode is selected, the user is prompted to edit the receive slope setting. This is accomplished using the UP/DOWN arrow keys. The user then presses ENTER.

- 3.2.25 (ODU,ENABLE,1:1,CSAT#1,CONFIG,RECEIVER) LNA
- (ODU,ENABLE,1:1,CSAT#2,CONFIG,RECEIVER) LNA
- (ODU,ENABLE,STAND-ALONE,CONFIG,RECEIVER) LNA

```
SELECT LNA: STATE CAL
CURR-WINDOW FAULT-LOGIC
```

The user is prompted to select 1 of 4 selection using the LEFT/RIGHT arrow keys, then to press ENTER.

- 3.2.26 (ODU,ENABLE,1:1,CSAT#1,CONFIG,RECEIVER,LNA) STATE
- (ODU,ENABLE,1:1,CSAT#2,CONFIG,RECEIVER,LNA) STATE
- (ODU,ENABLE,STAND-ALONE,CONFIG,RECEIVER,LNA) STATE

```
SELECT ODU LNA STATE:
ON OFF (PRESS ENTER)
```

The user is prompted to select either ON or OFF, using the LEFT/RIGHT arrow keys, then to press ENTER. This controls whether or not the CSAT will provide LNA POWER via the Receive RF Cable.

- 3.2.27 (ODU,ENABLE,1:1,CSAT#1,CONFIG,RECEIVER,LNA) CAL (Calibrate)
- (ODU,ENABLE,1:1,CSAT#2,CONFIG,RECEIVER,LNA) CAL (Calibrate)
- (ODU,ENABLE,STAND-ALONE,CONFIG,RECEIVER,LNA) CAL (Calibrate)

```
CALIBRATE LNA CURRENT?
CAL EXIT (PRESS ENTER)
```

The user is prompted to select either CAL or EXIT, using the LEFT/RIGHT arrow keys, then to press ENTER. This provides a means to calibrate the LNA current for use with the Current-Window function described below.

- 3.2.28 (ODU,ENABLE,1:1,CSAT#1,CONFIG,RECEIVER,LNA) CURR-WINDOW
- (ODU,ENABLE,1:1,CSAT#2,CONFIG,RECEIVER,LNA) CURR-WINDOW
- (ODU,ENABLE,STAND-ALONE,CONFIG,RECEIVER,LNA) CURR-WINDOW

```
EDIT LNA CURRENT WINDOW:
99 % (PRESS ENTER)
```

The user is prompted to edit the Current Window setting using the UP/Down arrow keys, then to press ENTER. The value will scroll between 20% and 50% to define the allowable LNA current change before declaring a fault. Selecting 99% disables the current window function.

- 3.2.29 (ODU,ENABLE,1:1,CSAT#1,CONFIG,RECEIVER,LNA) FAULT-LOGIC
- (ODU,ENABLE,1:1,CSAT#2,CONFIG,RECEIVER,LNA) FAULT-LOGIC
- (ODU,ENABLE,STAND-ALONE,CONFIG,RECEIVER,LNA) FAULT-LOGIC

```
SELECT LNA FAULT LOGIC :
SUMMARY NO SUMM (ENTER)
```

The user is prompted to select either SUMMARY or NO SUMM, using the LEFT/RIGHT arrow keys, then to press ENTER. This controls whether or not the a LNA Current-Window fault will activate the SUMMARY FAULT RELAY. This allows the user to select whether or not to switch the ONLINE/OFFLINE CSAT in the event of a LNA current-window fault.

- 3.2.30 (ODU,ENABLE,1:1,CSAT#1,CONFIG) MISCELLANEOUS
- (ODU,ENABLE,1:1,CSAT#2,CONFIG) MISCELLANEOUS
- (ODU,ENABLE,STAND-ALONE,CONFIG) MISCELLANEOUS

```
MISC : COLD-START AFR
XREF REF-ADJUST RTC
```

This menu item is used to select miscellaneous ODU parameter for modification. Use the LEFT/RIGHT arrow keys, then press ENTER.

- 3.2.31 (ODU,ENABLE,1:1,CSAT#1,CONFIG,MISCELLANEOUS) COLD-START
- (ODU,ENABLE,1:1,CSAT#2,CONFIG,MISCELLANEOUS) COLD-START
- (ODU,ENABLE,STAND-ALONE,CONFIG,MISCELLANEOUS) COLD-START

```
SELECT COLD START STATE :
ENABLED DISABLED (ENTER)
```

The user is prompted to select either ENABLED or DISABLED, using the LEFT/RIGHT arrow keys, then to press ENTER.

- 3.2.32 (ODU,ENABLE,1:1,CSAT#1,CONFIG,MISCELLANEOUS) AFR(Auto Flt Rec)
- (ODU,ENABLE,1:1,CSAT#2,CONFIG,MISCELLANEOUS) AFR(Auto Flt Rec)
- (ODU,ENABLE,STAND-ALONE,CONFIG,MISCELLANEOUS) AFR(Auto Flt Rec)

```
SEL AUTO FAULT RECOVERY :
ENABLED DISABLED (ENTER)
```

The user is prompted to select either ENABLED or DISABLED, using the LEFT/RIGHT arrow keys, then to press ENTER.

- 3.2.33 (ODU,ENABLE,1:1,CSAT#1,CONFIG,MISCELLANEOUS) XREF(Ext Ref)
- (ODU,ENABLE,1:1,CSAT#2,CONFIG,MISCELLANEOUS) XREF(Ext Ref)
- (ODU,ENABLE,STAND-ALONE,CONFIG,MISCELLANEOUS) XREF(Ext Ref)

```
SELECT EXT REFERENCE :
YES NO (PRESS ENTER)
```

The user is prompted to select either YES or NO, using the LEFT/RIGHT arrow keys, then to press ENTER. NOTE: The CSAT will automatically lock to an external 5 or 10 MHz reference independent of the state of this selection. This selection determines whether or not the Summary Fault Relay is activated if the CSAT loses lock with the external reference.

- 3.2.34 (ODU,ENABLE,1:1,CSAT#1,CONFIG,MISCELLANEOUS) REF-ADJUST
- (ODU,ENABLE,1:1,CSAT#2,CONFIG,MISCELLANEOUS) REF-ADJUST
- (ODU,ENABLE,STAND-ALONE,CONFIG,MISCELLANEOUS) REF-ADJUST

```
EDIT INT REF ADJUSTMENT: 087
(PRESS ENTER)
```

The user is prompted to edit the Internal 10MHz Reference setting using the UP/Down arrow keys, then to press ENTER. The value will scroll between 000 and 255. NOTE: The Internal Reference is adjusted in the factory to be very accurate with the default setting of 087. This parameter is made available to compensate for the long-term frequency drift of the oscillator.

- 3.2.35 (ODU,ENABLE,1:1,CSAT#1,CONFIG,MISCELLANEOUS) RTC
- (ODU,ENABLE,1:1,CSAT#2,CONFIG,MISCELLANEOUS) RTC
- (ODU,ENABLE,STAND-ALONE,CONFIG,MISCELLANEOUS) RTC

```
SYNC ODU RTC TO LCL RTC
YES NO (PRESS ENTER)
```

The user is prompted to select either YES or NO, using the LEFT/RIGHT arrow keys, then to press ENTER. Selecting YES will cause the CSAT RTC to be synchronized with the Modems RTC.

- 3.2.36 (ODU,ENABLE,1:1,CSAT#1) INFO (Information)
- (ODU,ENABLE,1:1,CSAT#2) INFO (Information)
- (ODU,ENABLE,STAND-ALONE) INFO (Information)

```
INFO: MODEL TRANSMITTER
RECEIVER MISC LNA(ENTER)
```

The operator uses this menu item to select enter 1 of 5 'Information Windows'. Use the LEFT/RIGHT arrow keys, then press ENTER.

3.2.37 (ODU,ENABLE,1:1,CSAT#1,INFO) MODEL
 (ODU,ENABLE,1:1,CSAT#2,INFO) MODEL
 (ODU,ENABLE,STAND-ALONE,INFO) MODEL

```
CSAT-5060/010 V2.09
SERIAL # 00225 (ENT)
```

This window provides the CSAT Model Number and Serail Number, press ENTER.

3.2.38 (ODU,ENABLE,1:1,CSAT#1,INFO) TRANSMITTER
 (ODU,ENABLE,1:1,CSAT#2,INFO) TRANSMITTER
 (ODU,ENABLE,STAND-ALONE,INFO) TRANSMITTER

```
Tx: ON 5845.0 10.00
AMP ON MUTE OFF 0.0
```

This window provides the CSAT Transmitter information including Tx Frequency, Tx Attenuation, Amplifier state, Tx Mute state and Tx Slope adjustment, press ENTER.

3.2.39 (ODU,ENABLE,1:1,CSAT#1,INFO) RECEIVER
 (ODU,ENABLE,1:1,CSAT#2,INFO) RECEIVER
 (ODU,ENABLE,STAND-ALONE,INFO) RECEIVER

```
Rx: ON 3625.0 10.00
MUTE OFF 0.0
```

This window provides the CSAT Receiver information including Rx Frequency, Rx Attenuation, Rx Mute state and Rx Slope adjustment, press ENTER.

3.2.40 (ODU,ENABLE,1:1,CSAT#1,INFO) MISC
 (ODU,ENABLE,1:1,CSAT#2,INFO) MISC
 (ODU,ENABLE,STAND-ALONE,INFO) MISC

```
COLD START = OFF
AUTO FLT REC = ON
```

This window provides the current state of the Cold Start and Auto Fault Recovery functions, press ENTER.

3.2.41 (ODU,ENABLE,1:1,CSAT#1,INFO) LNA
 (ODU,ENABLE,1:1,CSAT#2,INFO) LNA
 (ODU,ENABLE,STAND-ALONE,INFO) LNA

```
LNA: ON WINDOW: 99%
FAULT LOGIC: NO SUMMARY
```

This window provides the current state of the LNA functions, press ENTER.

- 3.2.42 (ODU,ENABLE,1:1,CSAT#1) MONITOR
- (ODU,ENABLE,1:1,CSAT#2) MONITOR
- (ODU,ENABLE,STAND-ALONE) MONITOR

```
MONITOR: TX RX MISC
PWR SUPP1 PWR SUPP2
```

The operator uses this menu item to select enter 1 of 5 ‘Monitor Windows’. Use the LEFT/RIGHT arrow keys, then press ENTER.

- 3.2.43 (ODU,ENABLE,1:1,CSAT#1,MONITOR) TX (Transmitter)
- (ODU,ENABLE,1:1,CSAT#2,MONITOR) TX (Transmitter)
- (ODU,ENABLE,STAND-ALONE,MONITOR) TX (Transmitter)

```
TX: SYNTUNE=04.8 PWR=040
IFLO = 10.7 TEMP= 27C
```

This window provides the Tx Synthesizer and IFLO tuning voltages, the RF Output Power in dBm and the Transmitter temperature, press ENTER.

- 3.2.44 (ODU,ENABLE,1:1,CSAT#1,MONITOR) RX (Receiver)
- (ODU,ENABLE,1:1,CSAT#2,MONITOR) RX (Receiver)
- (ODU,ENABLE,STAND-ALONE,MONITOR) RX (Receiver)

```
RX: SYNTH TUNE = 03.1
IFLO = 10.9 TEMP= 28C
```

This window provides the Rx Synthesizer and IFLO tuning voltages and the Receiver temperature, press ENTER.

- 3.2.45 (ODU,ENABLE,1:1,CSAT#1,MONITOR) MISC
- (ODU,ENABLE,1:1,CSAT#2,MONITOR) MISC
- (ODU,ENABLE,STAND-ALONE,MONITOR) MISC

```
MISC: REF TUNE = 03.0
LNA=000. mA FAN=568 mA
```

This window provides the Internal Reference Oscillator tuning voltages, the LNA Current in milliamps and the Fan Current in milliamps, press ENTER.

- 3.2.46 (ODU,ENABLE,1:1,CSAT#1,MONITOR) PWR SUPP1
- (ODU,ENABLE,1:1,CSAT#2,MONITOR) PWR SUPP1
- (ODU,ENABLE,STAND-ALONE,MONITOR) PWR SUPP1

```
PS: 24V=23.8 20V=22.6
12V=13.0 10V=10.1
```

This window provides a monitor for four of the six internal power supplies, press ENTER.

3.2.47 **(ODU,ENABLE,1:1,CSAT#1,MONITOR)** **PWR SUPP2**
 (ODU,ENABLE,1:1,CSAT#2,MONITOR) **PWR SUPP2**
 (ODU,ENABLE,STAND-ALONE,MONITOR) **PWR SUPP2**

```
PS: +5V=5.5      -5V=-4.9
```

This window provides a monitor for the remaining two internal power supplies, press ENTER.

3.2.48 **(ODU,ENABLE,1:1,CSAT#1)** **ALARMS**
 (ODU,ENABLE,1:1,CSAT#2) **ALARMS**
 (ODU,ENABLE,STAND-ALONE) **ALARMS**

```
ALARMS:      CURRENT            STORED
                    (PRESS ENTER)
```

The operator uses this menu item to view either CURRENT Alarm Status or the STORED Alarms Log. Use the LEFT/RIGHT arrow keys, then press ENTER.

3.2.49 **(ODU,ENABLE,1:1,CSAT#1,ALARMS)** **CURRENT**
 (ODU,ENABLE,1:1,CSAT#2,ALARMS) **CURRENT**
 (ODU,ENABLE,STAND-ALONE,ALARMS) **CURRENT**

```
TX = OK      RX = OK
PWR SUP = OK      MISC = OK
```

The operator uses this menu item to view CURRENT Alarm Status. This window provides a summary of the current CSAT status, if any of the 4 items displays “FT” the operator should view the STORED Alarms Log for details.

3.2.50 **(ODU,ENABLE,1:1,CSAT#1,ALARMS)** **STORED**
 (ODU,ENABLE,1:1,CSAT#2,ALARMS) **STORED**
 (ODU,ENABLE,STAND-ALONE,ALARMS) **STORED**

```
STORED EVENTS:      VIEW
CLEAR ALL      (PRESS ENTER)
```

The operator uses this menu item to either VIEW or CLEAR the Stored Events Log using the LEFT/RIGHT arrow keys, then press ENTER.

- 3.2.51** **(ODU,ENABLE,1:1,CSAT#1,ALARMS,STORED)** **VIEW**
 (ODU,ENABLE,1:1,CSAT#2,ALARMS,STORED) **VIEW**
 (ODU,ENABLE,STAND-ALONE,ALARMS,STORED) **VIEW**

```
LOG 02:11/13/99 10:42:47
OK- REF LOCK (UP/DWN)
```

The operator uses the UP/DOWN arrow keys to sequentially view the individual entries in the Stored Events Log, then press CLEAR to exit the window.

- 3.2.52** **(ODU,ENABLE,1:1,CSAT#1,ALARMS,STORED)** **CLEAR ALL**
 (ODU,ENABLE,1:1,CSAT#2,ALARMS,STORED) **CLEAR ALL**
 (ODU,ENABLE,STAND-ALONE,ALARMS,STORED) **CLEAR ALL**

```
PRESS ENTER TO
CLEAR THE EVENTS LOG
```

The operator the ENTER key to clear the event log, else press CLEAR to exit the window.

METRIC CONVERSIONS

Units of Length

Unit	Centimeter	Inch	Foot	Yard	Mile	Meter	Kilometer	Millimeter
1 centimeter	—	0.3937	0.03281	0.01094	6.214×10^{-6}	0.01	—	—
1 inch	2.540	—	0.08333	0.2778	1.578×10^{-5}	0.254	—	25.4
1 foot	30.480	12.0	—	0.3333	1.893×10^{-4}	0.3048	—	—
1 yard	91.44	36.0	3.0	—	5.679×10^{-4}	0.9144	—	—
1 meter	100.0	39.37	3.281	1.094	6.214×10^{-4}	—	—	—
1 mile	1.609×10^5	6.336×10^4	5.280×10^3	1.760×10^3	—	1.609×10^3	1.609	—
1 mm	—	0.03937	—	—	—	—	—	—
1 kilometer	—	—	—	—	0.621	—	—	—

Temperature Conversions

Unit	° Fahrenheit	° Centigrade
	—	0 (water freezes)
32° Fahrenheit	—	0
	—	100 (water boils)
212° Fahrenheit	—	100
	—	273.1 (absolute 0)
-459.6° Fahrenheit	—	273.1

Formulas
$C = (F - 32) * 0.555$
$F = (C * 1.8) + 32$

Units of Weight

Unit	Gram	Ounce Avoirdupois	Ounce Troy	Pound Avoir.	Pound Troy	Kilogram
1 gram	—	0.03527	0.03215	0.002205	0.002679	0.001
1 oz. avoir.	28.35	—	0.9115	0.0625	0.07595	0.02835
1 oz. troy	31.10	1.097	—	0.06857	0.08333	0.03110
1 lb. avoir.	453.6	16.0	14.58	—	1.215	0.4536
1 lb. Troy	373.2	13.17	12.0	0.8229	—	0.3732
1 kilogram	1.0×10^3	35.27	32.15	2.205	2.679	—



2114 WEST 7TH STREET TEMPE ARIZONA 85281 USA
480 • 333 • 2200 PHONE
480 • 333 • 2161 FAX